

TITANIC

LIBRO 1

→ Una cartolina della White Star Line raffigurante il Titanic.

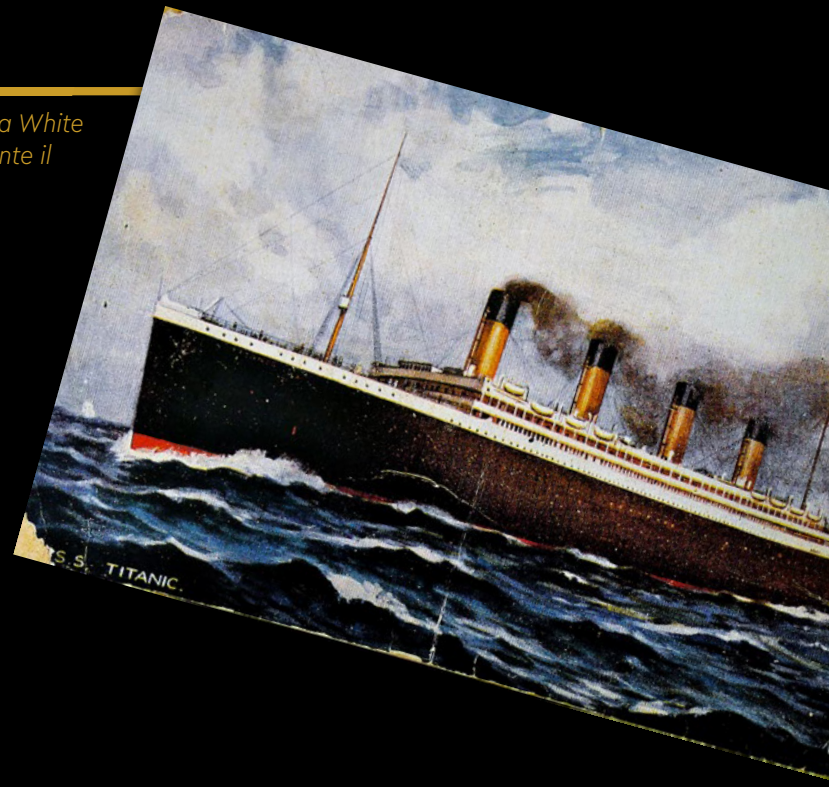

LA REGINA DEGLI OCEANI

Quando l'RMS *Titanic* lasciò il porto di Southampton, in Inghilterra, il 10 aprile 1912, per il suo viaggio inaugurale con destinazione New York, non era solo la più grande nave dell'epoca, ma anche la più lussuosa. Era il secondo dei tre transatlantici *Olympic* commissionati dalla società White Star Line nel tentativo di mantenere il dominio della compagnia sulle rotte passeggeri oceaniche altamente competitive. Costruito presso i cantieri navali di Belfast, Harland and Wolff, senza badare a spese, il *Titanic* offriva un livello di comfort e lusso senza precedenti.



↑ L'RMS Titanic in partenza da
Southampton il 10 aprile 1912.

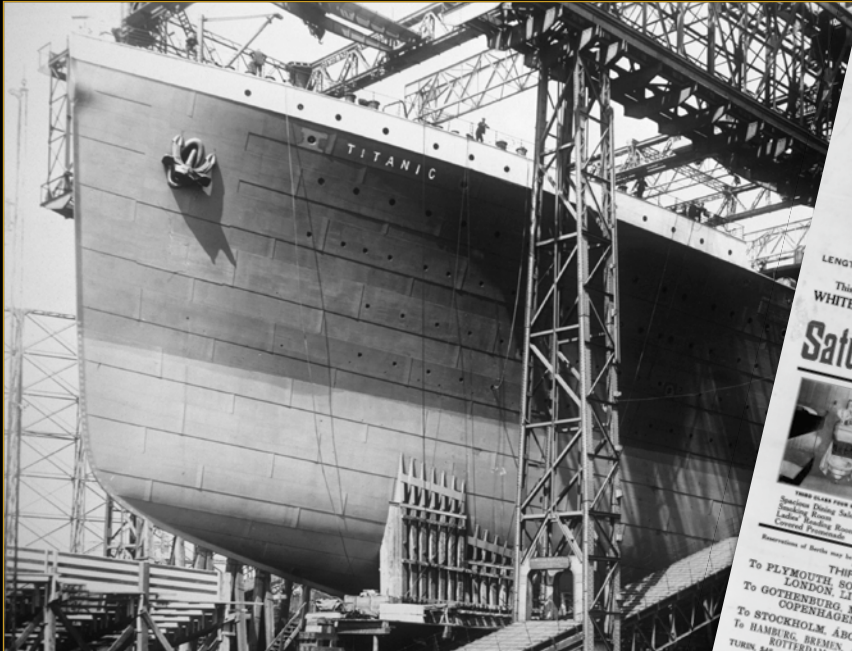

↑ La prua del Titanic in costruzione presso i cantieri navali Harland and Wolff a Belfast, Irlanda.

WHITE STAR LINE
 ROYAL & UNITED STATES MAIL STEAMERS
 FIRST SAILING OF THE LATEST ADDITION TO THE WHITE STAR FLEET
 The Queen of the Ocean
TITANIC

LENGTH 682 FT. OVER 45,000 TONS TRIPLE-SCREWS BEAM 92 FT.
 This, the Latest, Largest and Finest Steamer Afloat, will sail from
WHITE STAR LINE, PIER 59 (North River), NEW YORK

Saturday, April 20th At 12 Noon

THIRD CLASS COOK ROOM
 Spacious, Clean, Well-lit
 Ladies' Smoking Room
 General Promenade

THIRD CLASS DINING SALON
 All passengers booked in closed rooms
 containing 2, 4, or 6 berths, a large room
 bar equipped with wait-staff, etc.

Representatives of Berths may be made direct with the Office or through one of our accredited Agents

THIRD CLASS RATES ARE:

To PLYMOUTH SOUTHAMPTON LONDON LIVERPOOL and GLASGOW.	\$36.25
To GOTHENBURG MALMÖ CHRISTIANIA, COPENHAGEN, ESBJERG, Etc.	41.50
To STOCKHOLM, ÅBO, HANGÖ, HELSINGFORS, HAMBURG, BREMEN, ANTWERP, AMSTERDAM, ROTTERDAM, HAVRE, CHERBOURG, TURIN, GENOA, NAPLES, BRINDISI, PIRAEUS, ETC.	44.50
DO NOT DELAY. <small>Passage and other charges through the White Star Line Agents or direct from</small>	45.00

WHITE STAR LINE, 9 Broadway, New York
TICKETS FOR SALE HERE

← 1912: una pubblicità del lussuoso transatlantico Titanic che annuncia l'ora della partenza del viaggio inaugurale della nave. Contiene anche i prezzi dei biglietti e le descrizioni delle cabine.



→ Due transatlantici White Star Line, RMS Titanic e RMS Olympic, visti insieme per l'ultima volta, il 3 febbraio 1912.

IL TRANSATLANTICO OLYMPIC A TRE ELICHE

Il *Titanic* era alimentato da tre potenti motori, ognuno dei quali azionava la propria elica. I due motori a vapore esterni erano lunghi 19 metri, pesavano 720 tonnellate ed erogavano una potenza combinata di 30.000 CV. La turbina centrale a bassa pressione aggiungeva altri 16.000 CV. Per alimentare i motori a vapore erano necessari 29 caldaie, 484,5 tonnellate di acqua e 600 tonnellate di carbone al giorno. I tre motori erano collegati direttamente alle eliche tramite lunghi alberi. Le due enormi eliche esterne avevano un diametro di 7,2 metri, mentre quella centrale, più piccola, aveva un diametro di 5,2 metri. Tutta questa potenza conferiva al *Titanic* una velocità massima di 23 nodi (42,5 km/h).

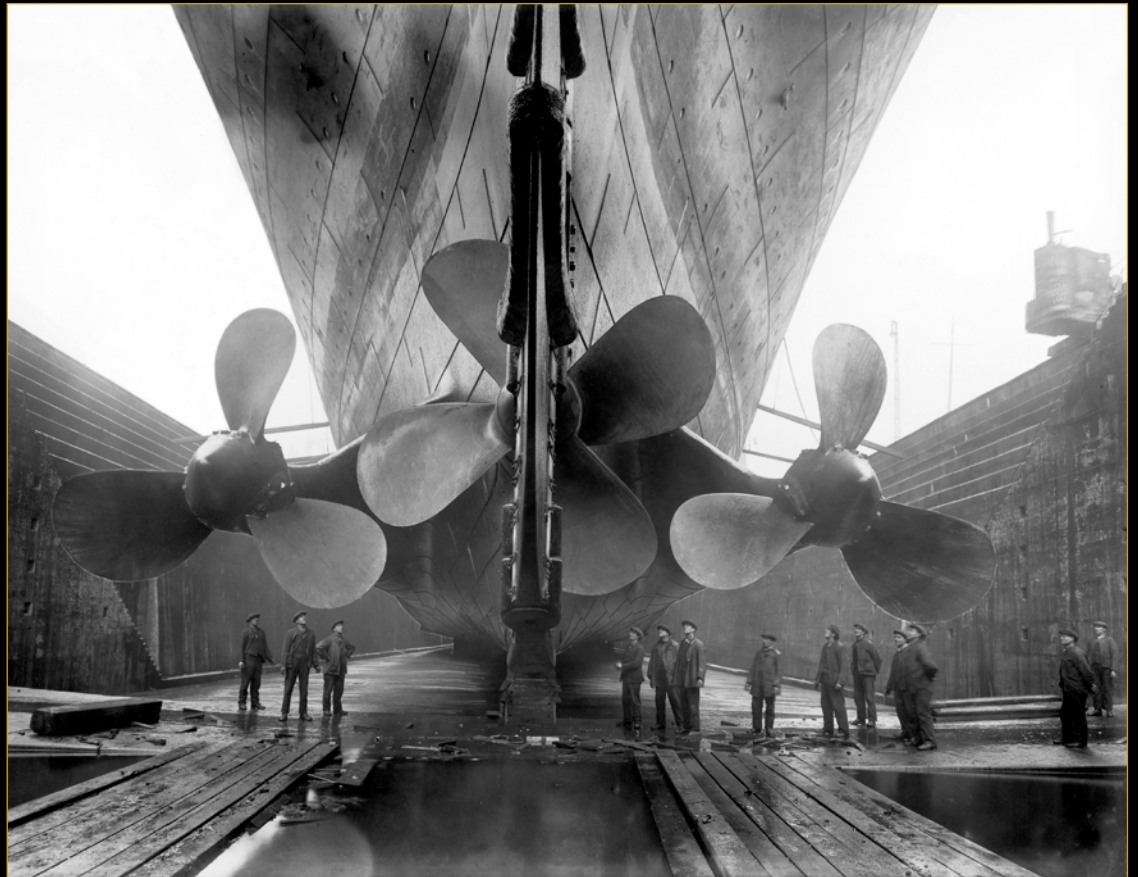

↑ Le enormi eliche dell'RMS Titanic con l'imbarcazione a secco nel bacino di carenaggio.



LEGO.com/brickseparator

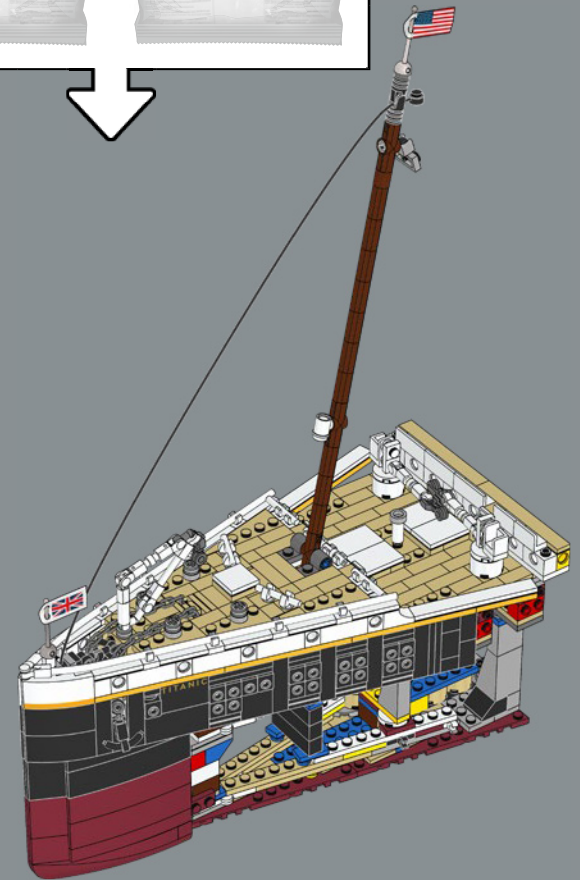
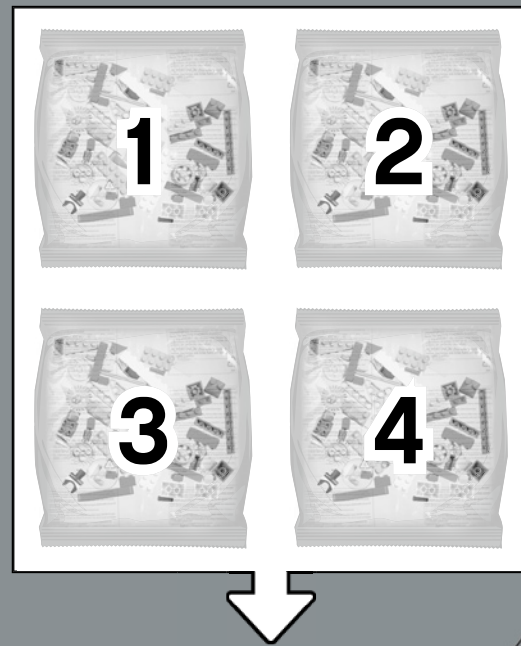

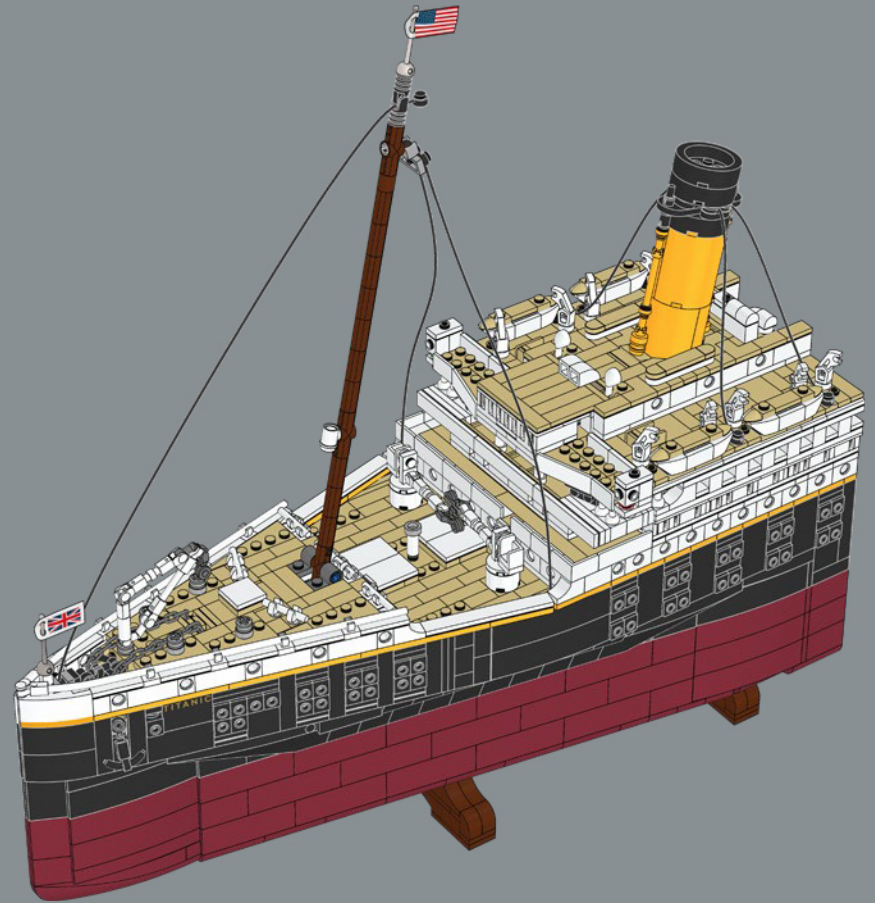
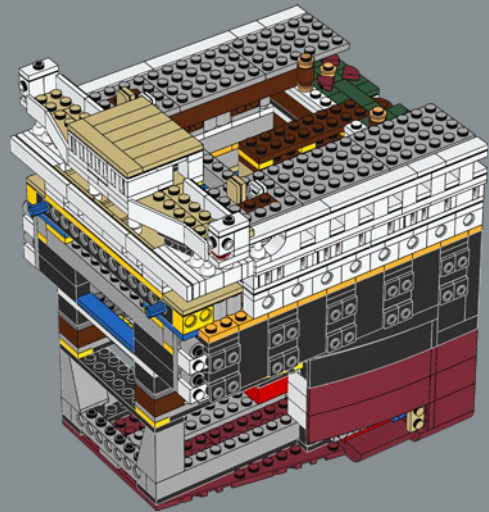

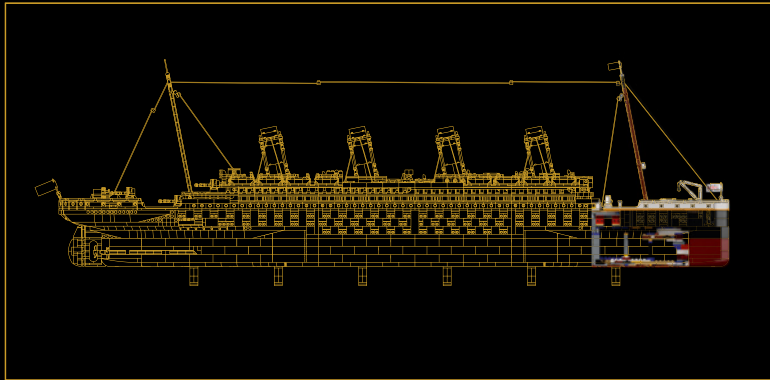

SEZIONE 1:

PRUA E COPERTA A POZZO

In questa sezione, costruirai la prua della nave insieme alle ancore, il nome del transatlantico, la coperta a pozzo, i portelli di carico e le gru di carico, la gru dell'ancora con la terza ancora e l'albero di prua. All'interno della nave, è possibile costruire anche le strutture di supporto dello scafo prodiero inclinato. Nelle sezioni successive, queste strutture saranno combinate con i supporti per bloccare insieme e rifinire lo scafo prodiero del modello.

↓ Per realizzare la parte anteriore della chiglia del modello, abbiamo utilizzato mattoncini tripli curvi 2x10x2.



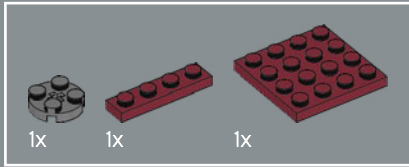
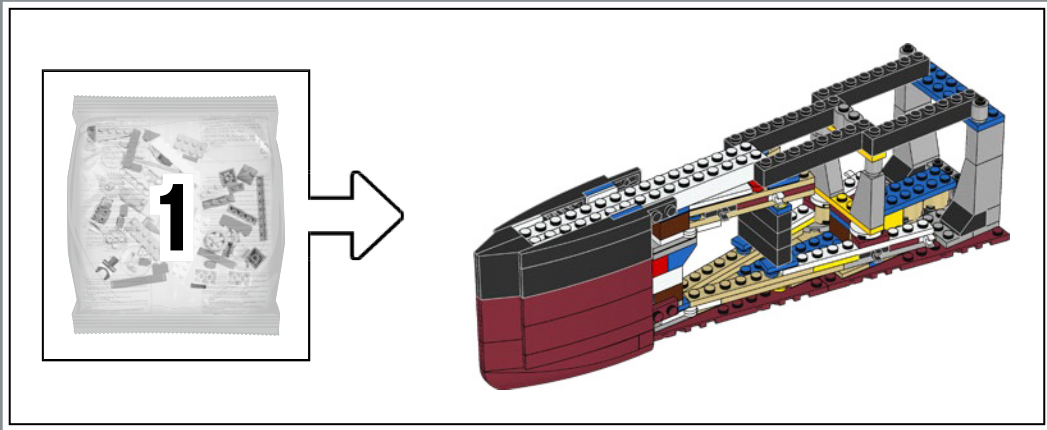

2

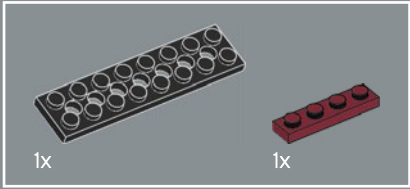

1

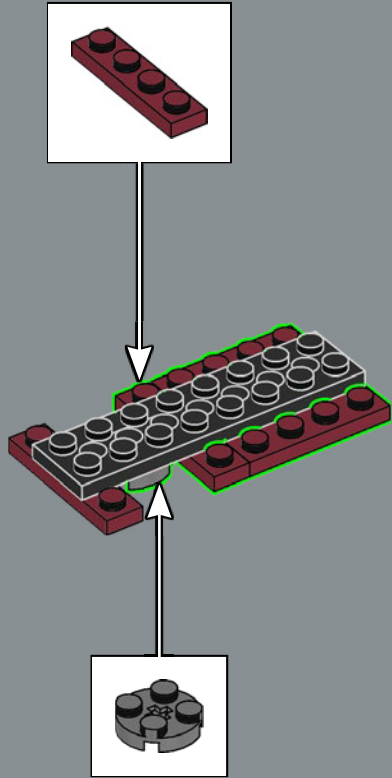
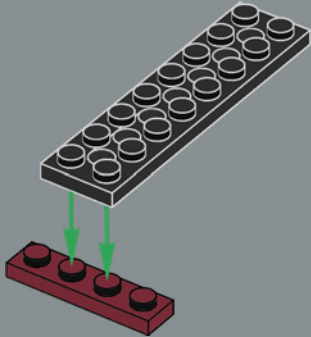

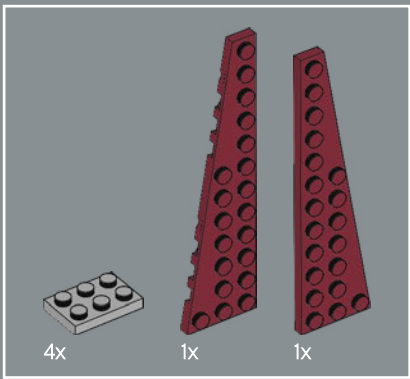

3

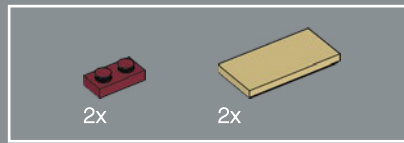
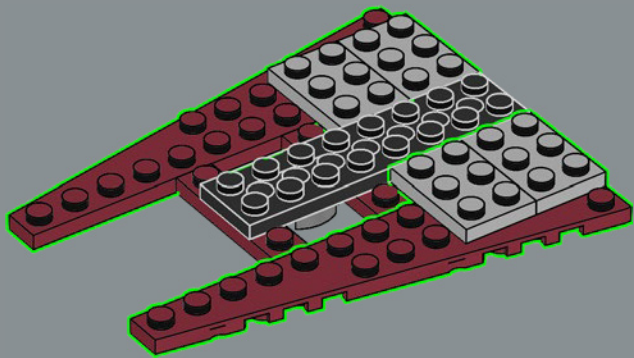

4

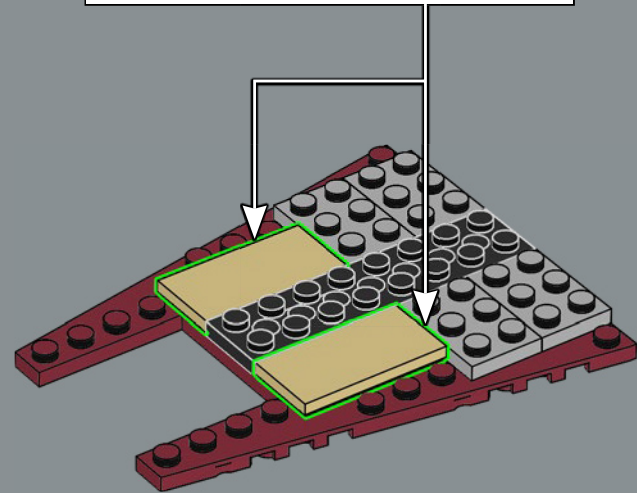
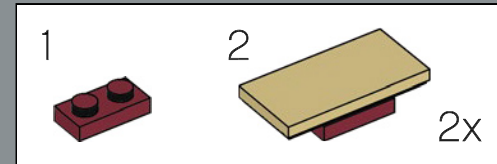

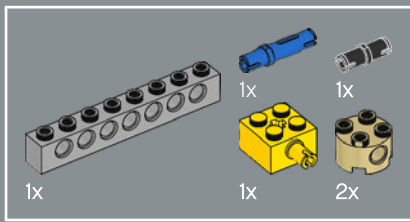

5

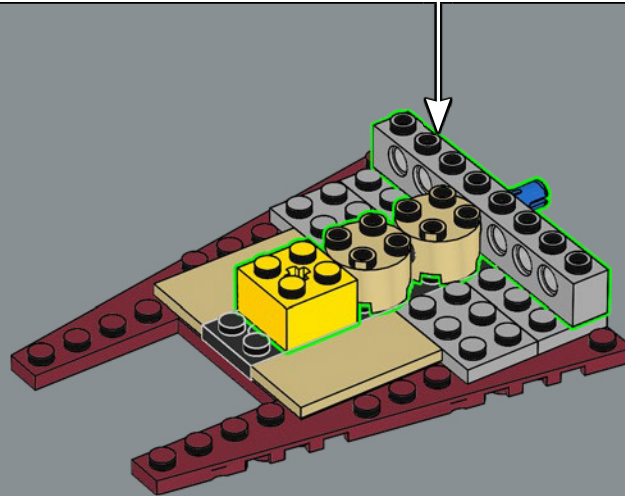
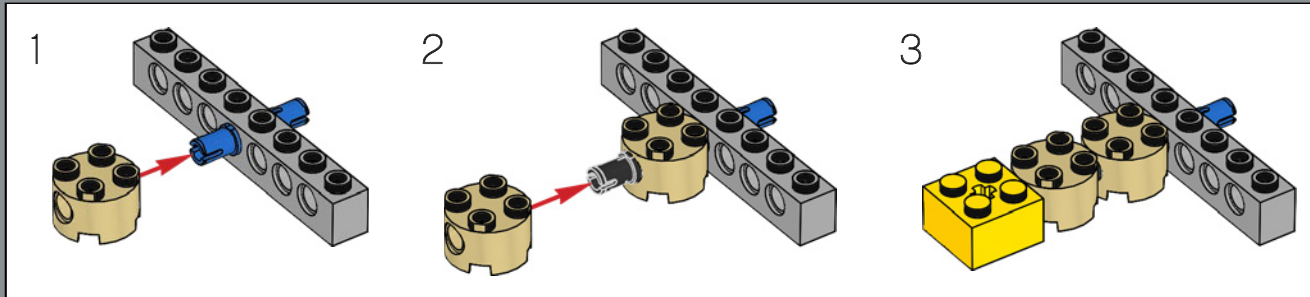

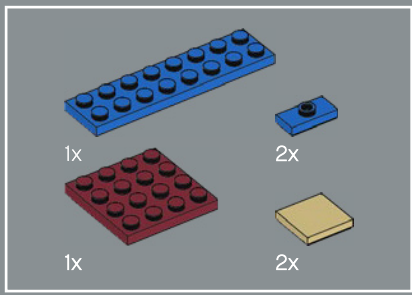

6

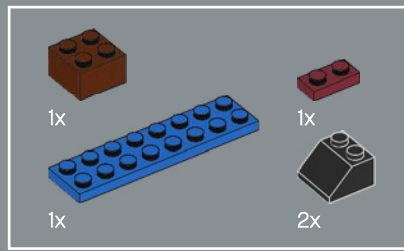
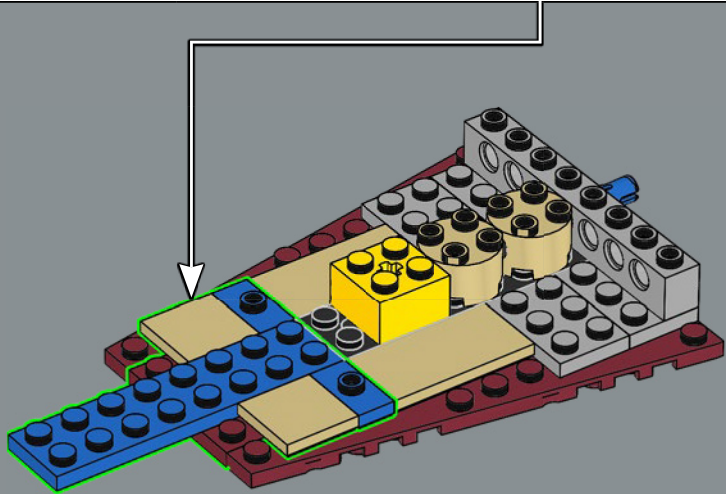
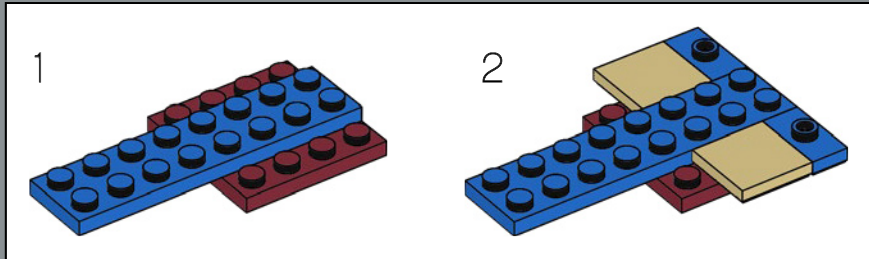

7

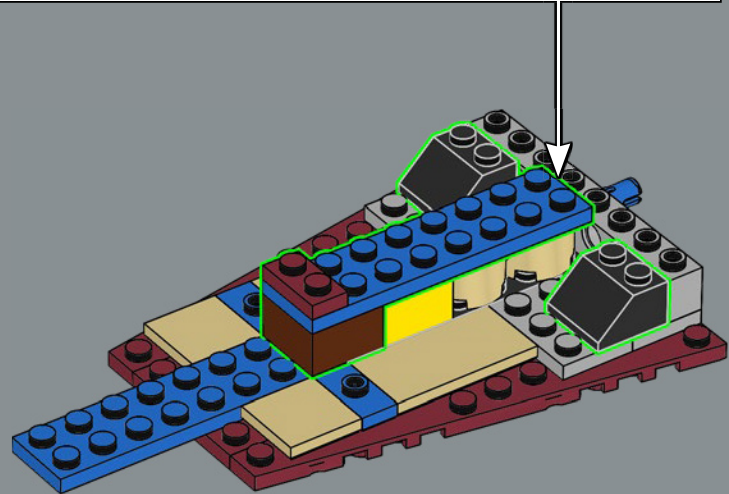
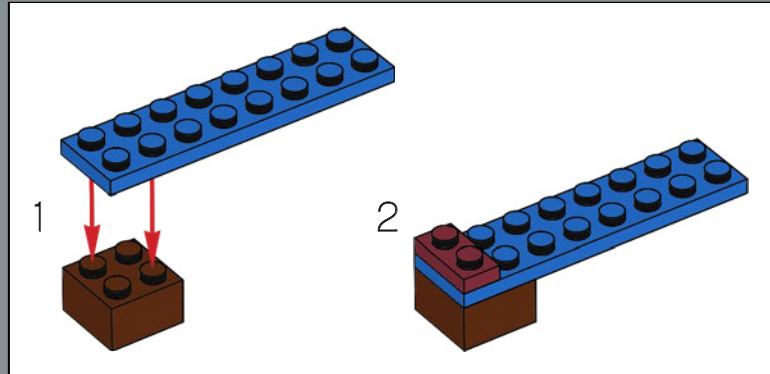

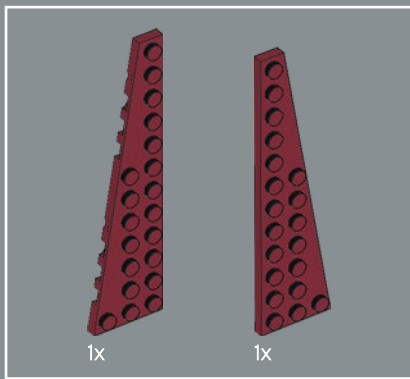

8

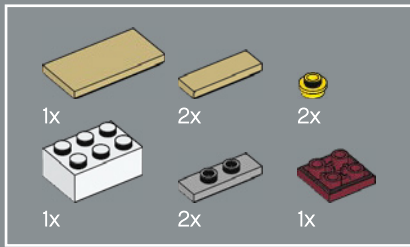
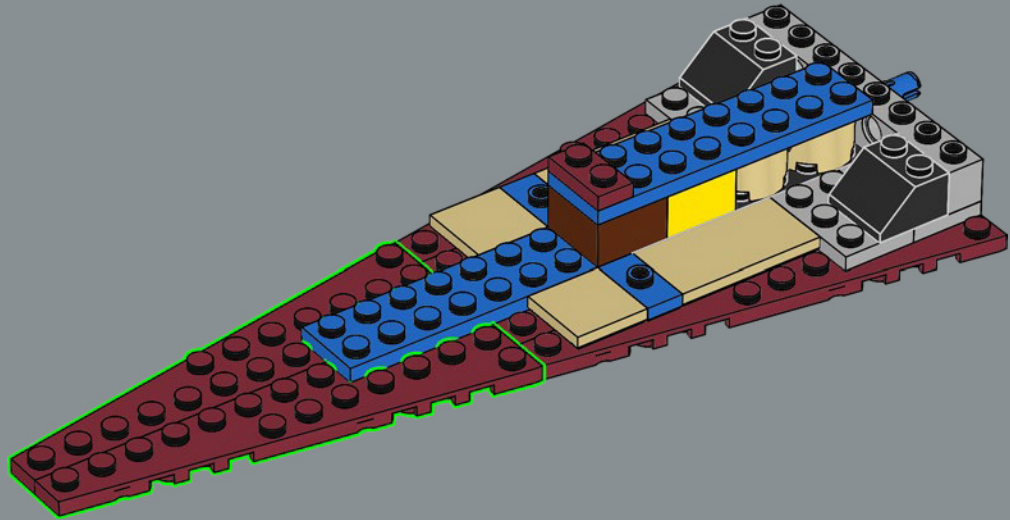

9

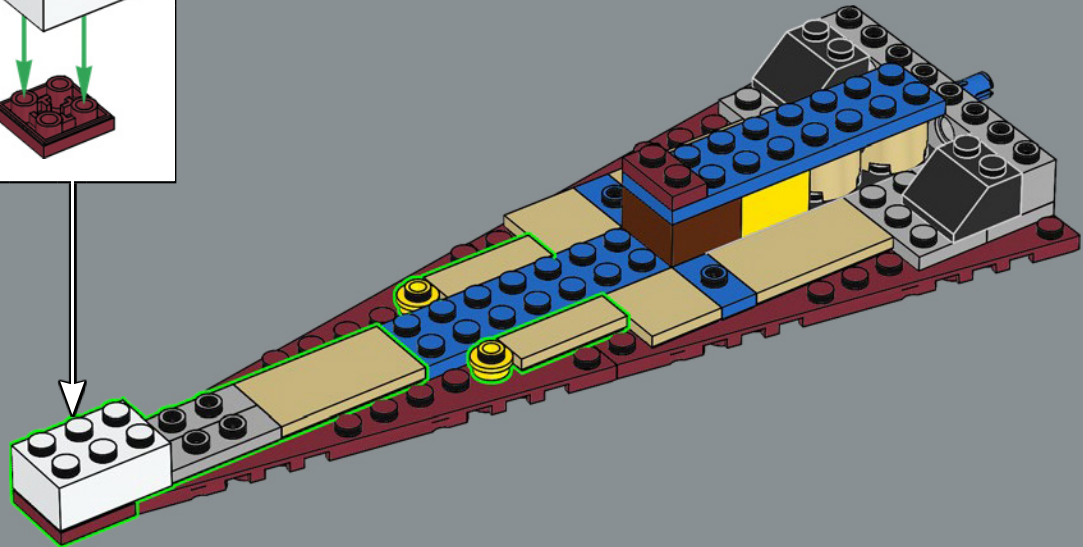
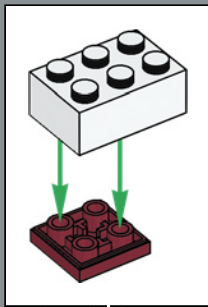

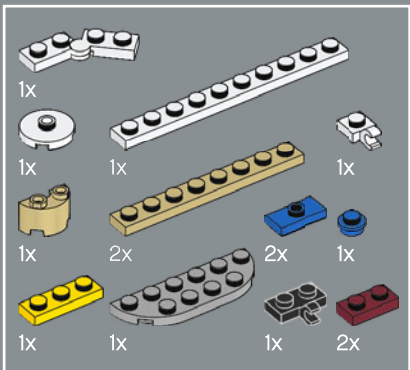

10

1

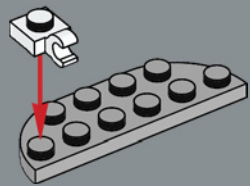

2

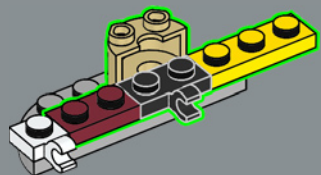

3

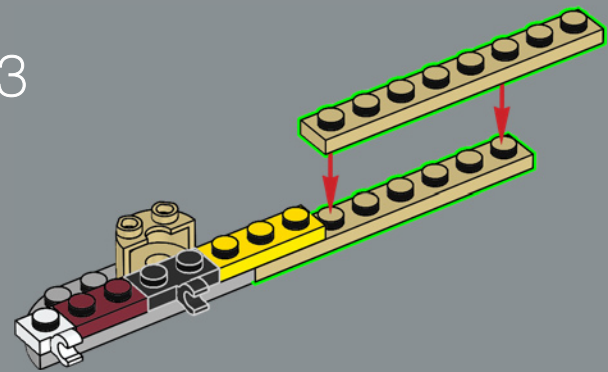

4

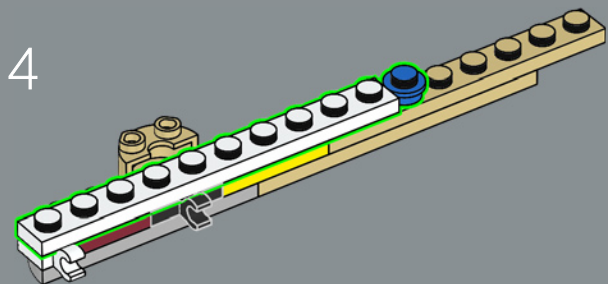

5

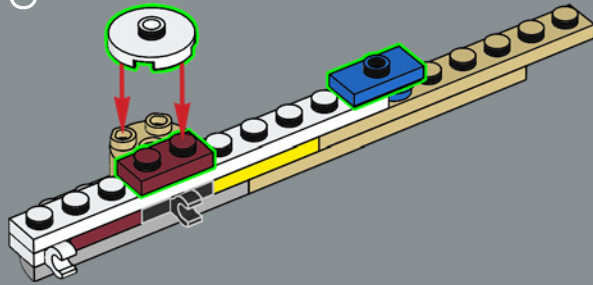

6

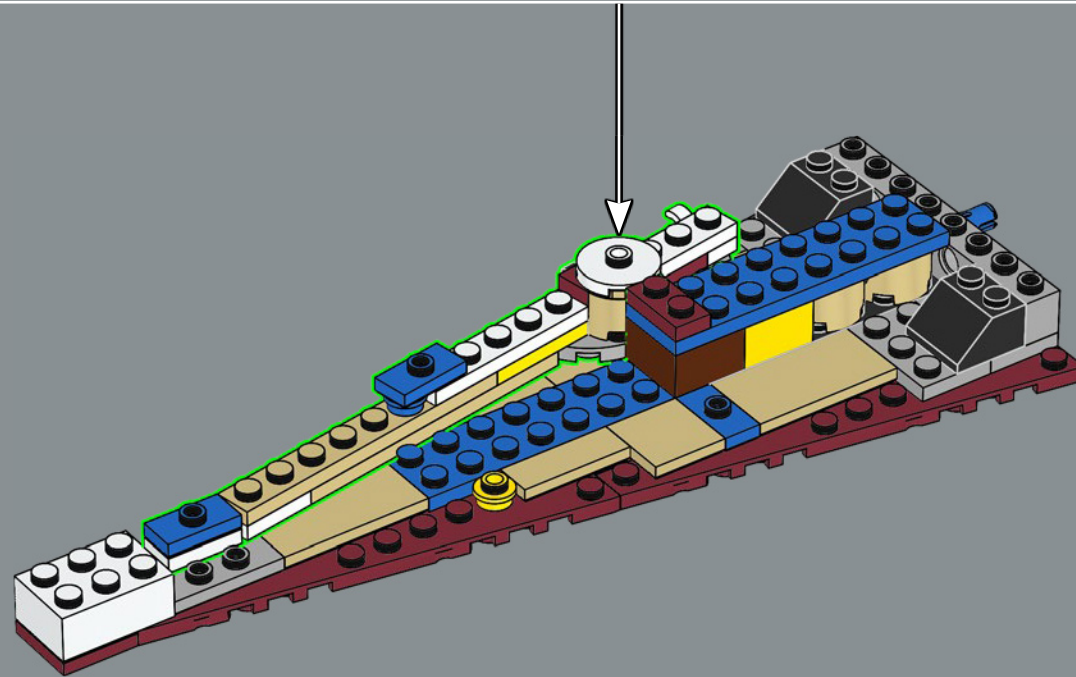
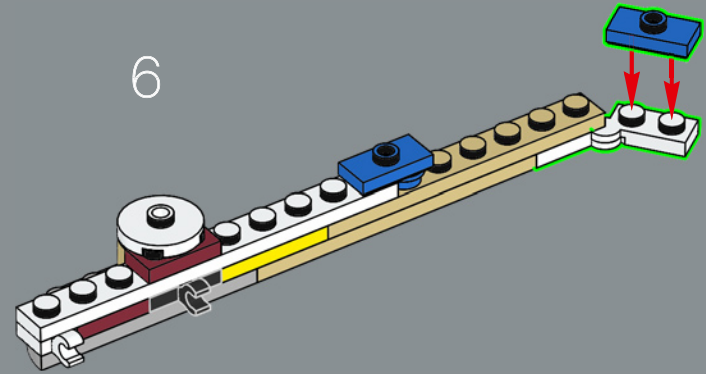

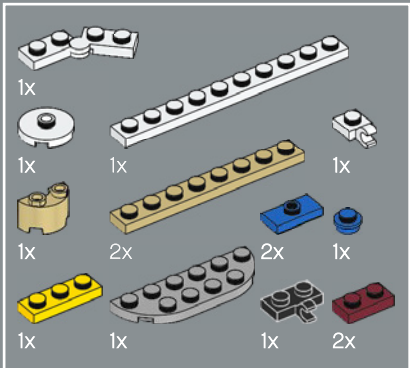

11

1

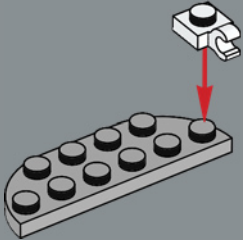

2

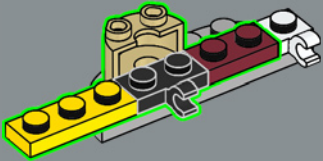

3

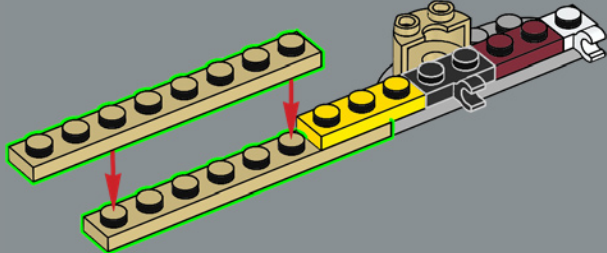

4

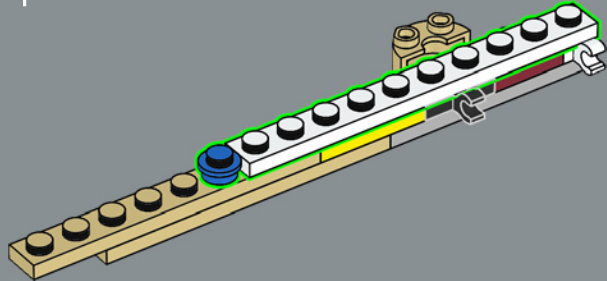

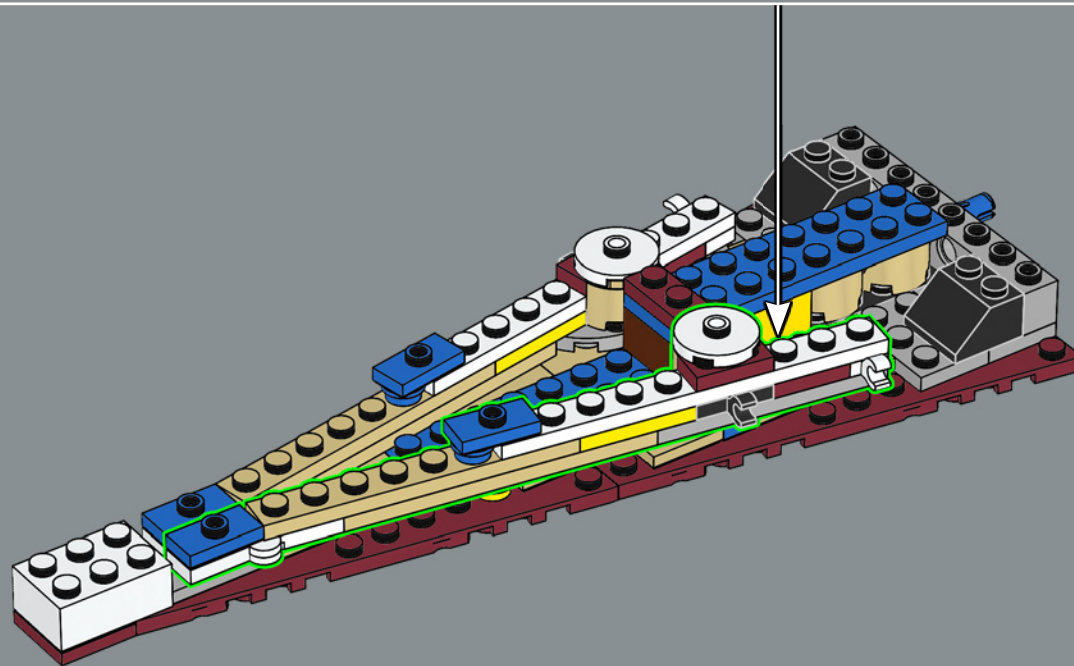
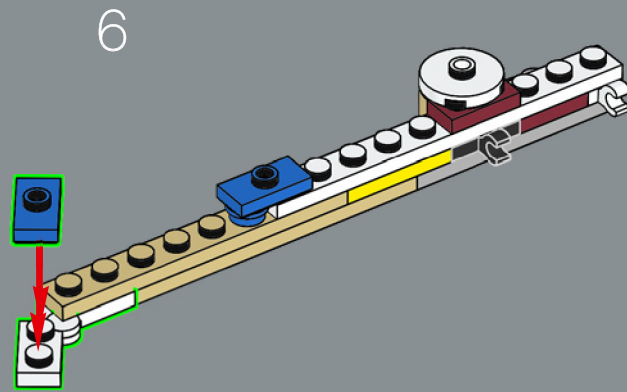
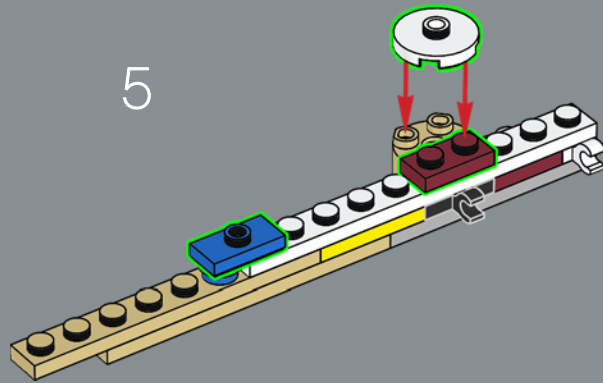

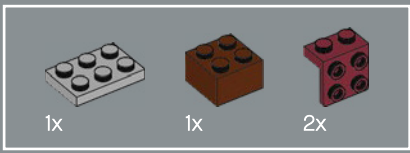

12

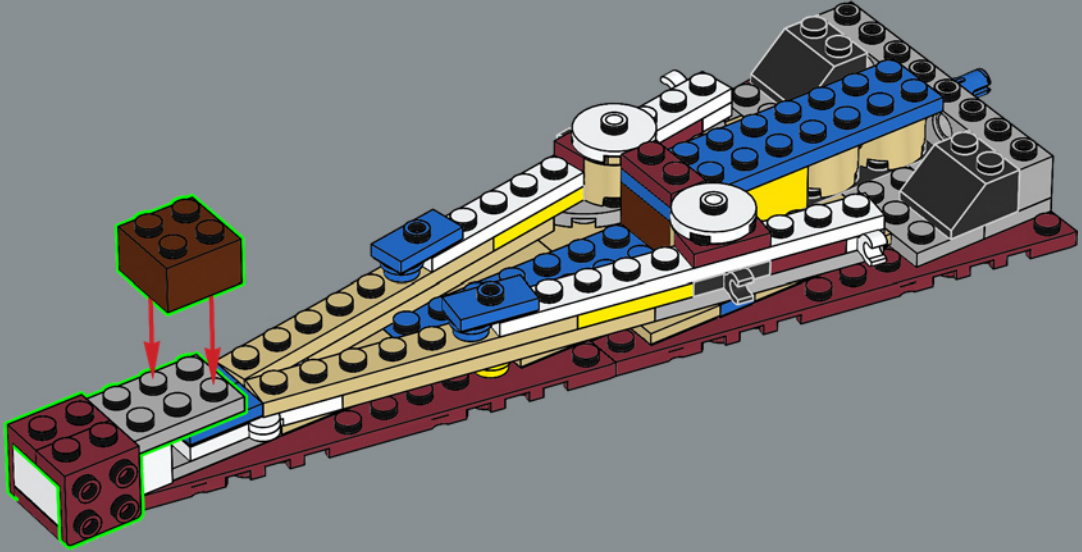

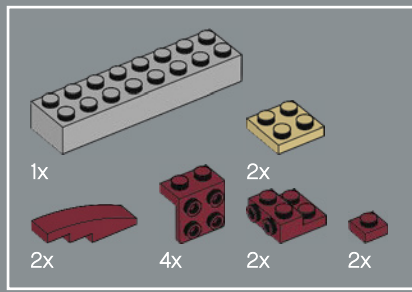

13

1

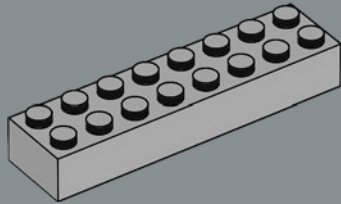

2

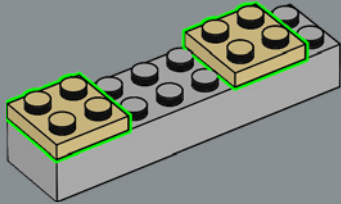

3

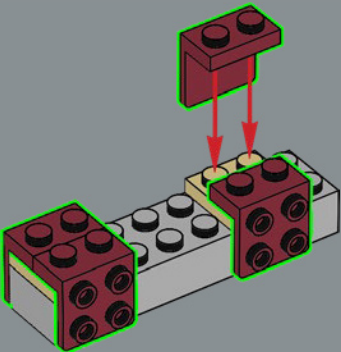

4

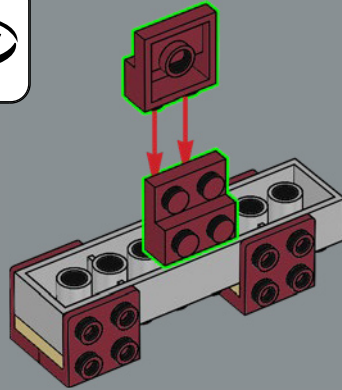

5

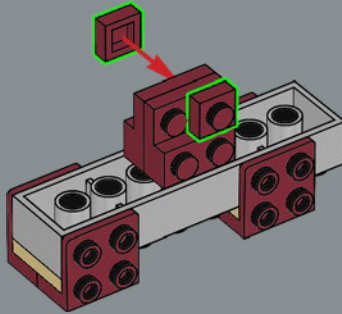

6

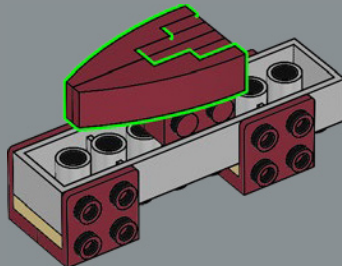

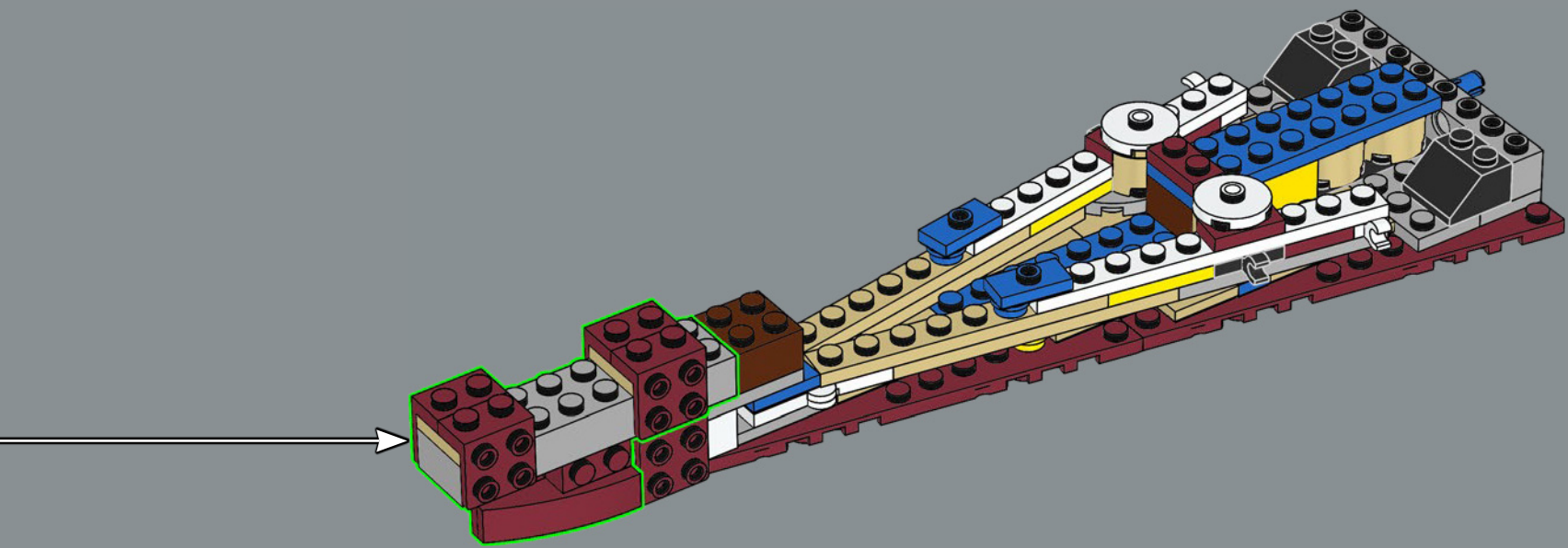

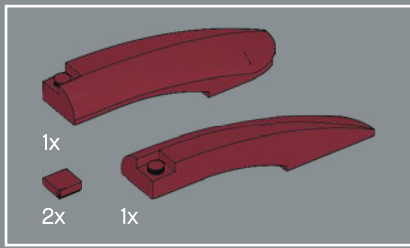

14

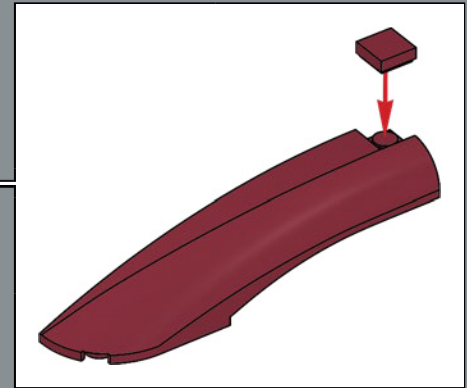
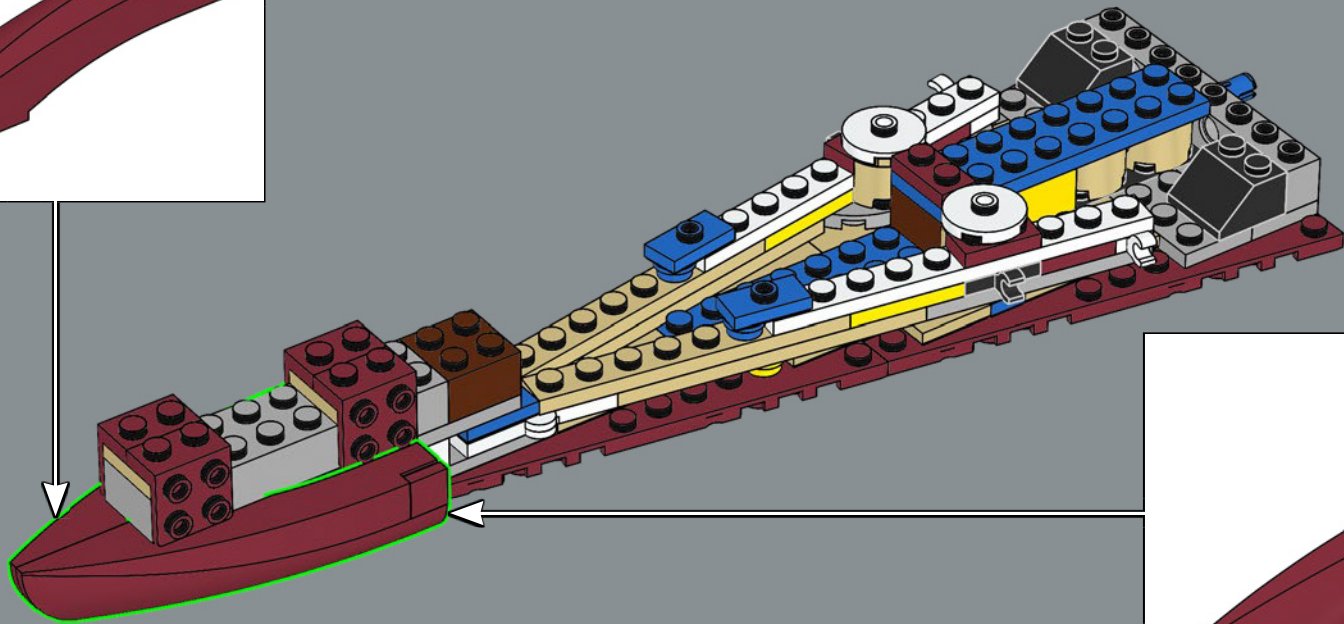
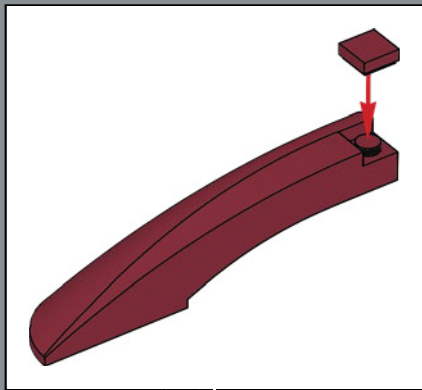

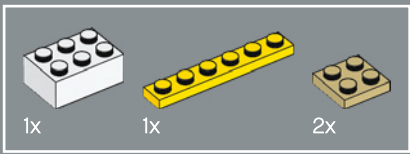

15

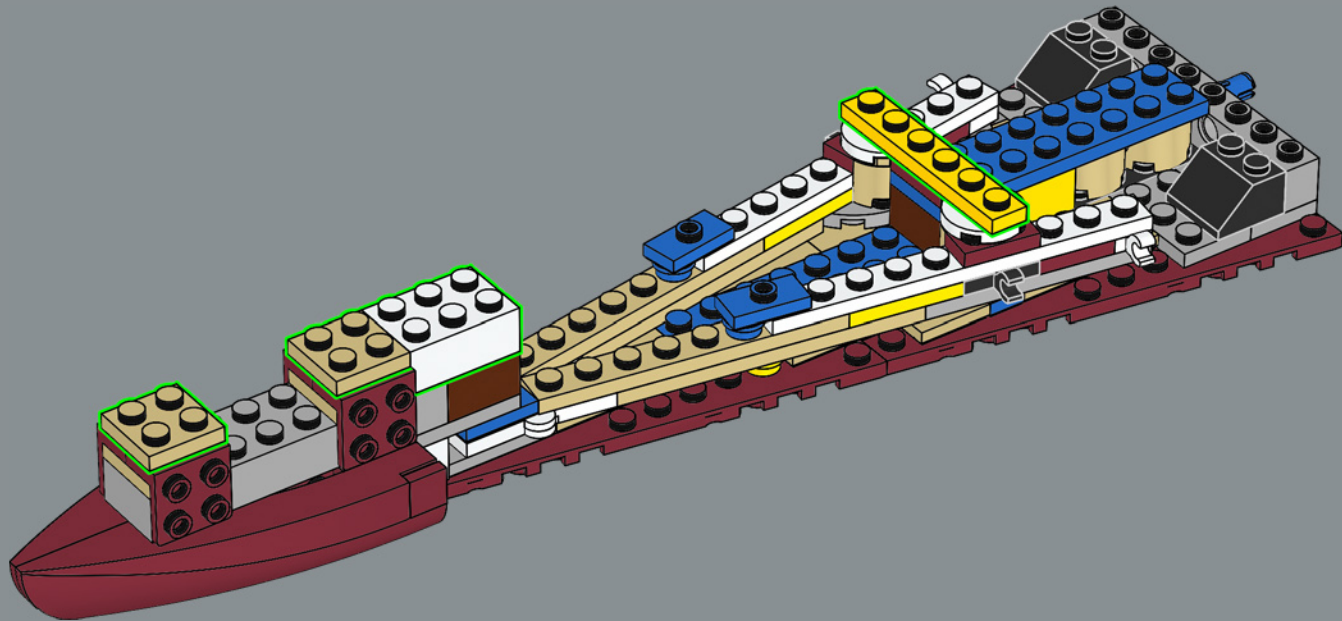

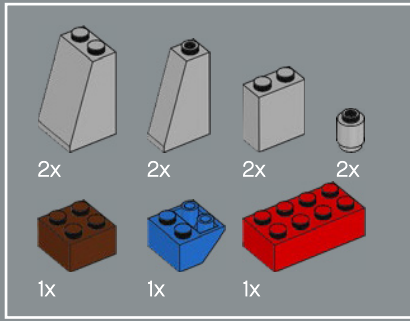

16

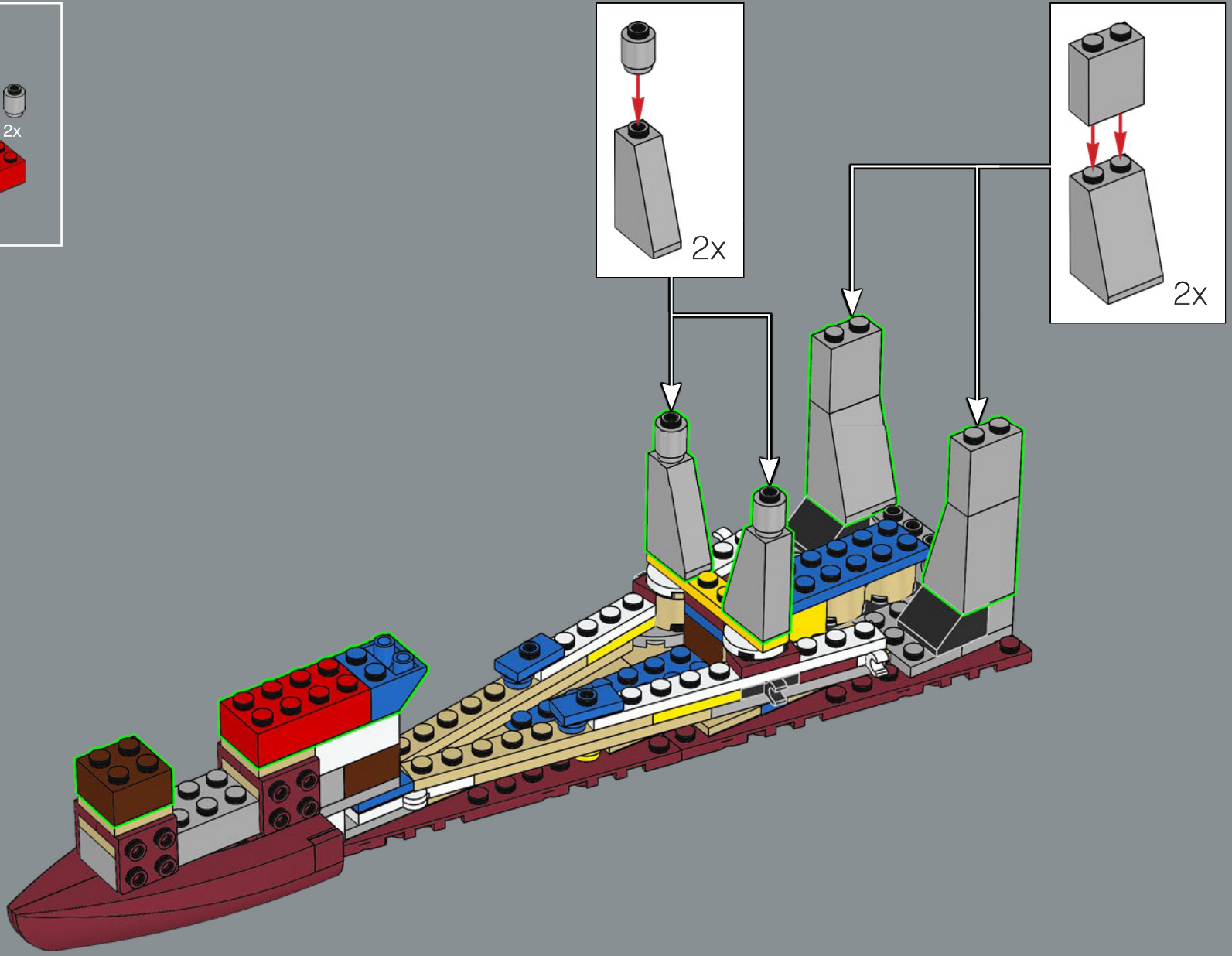

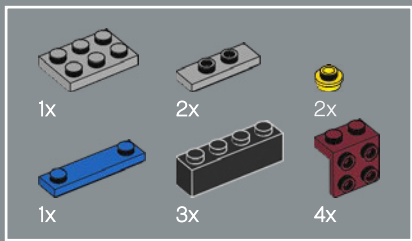

17

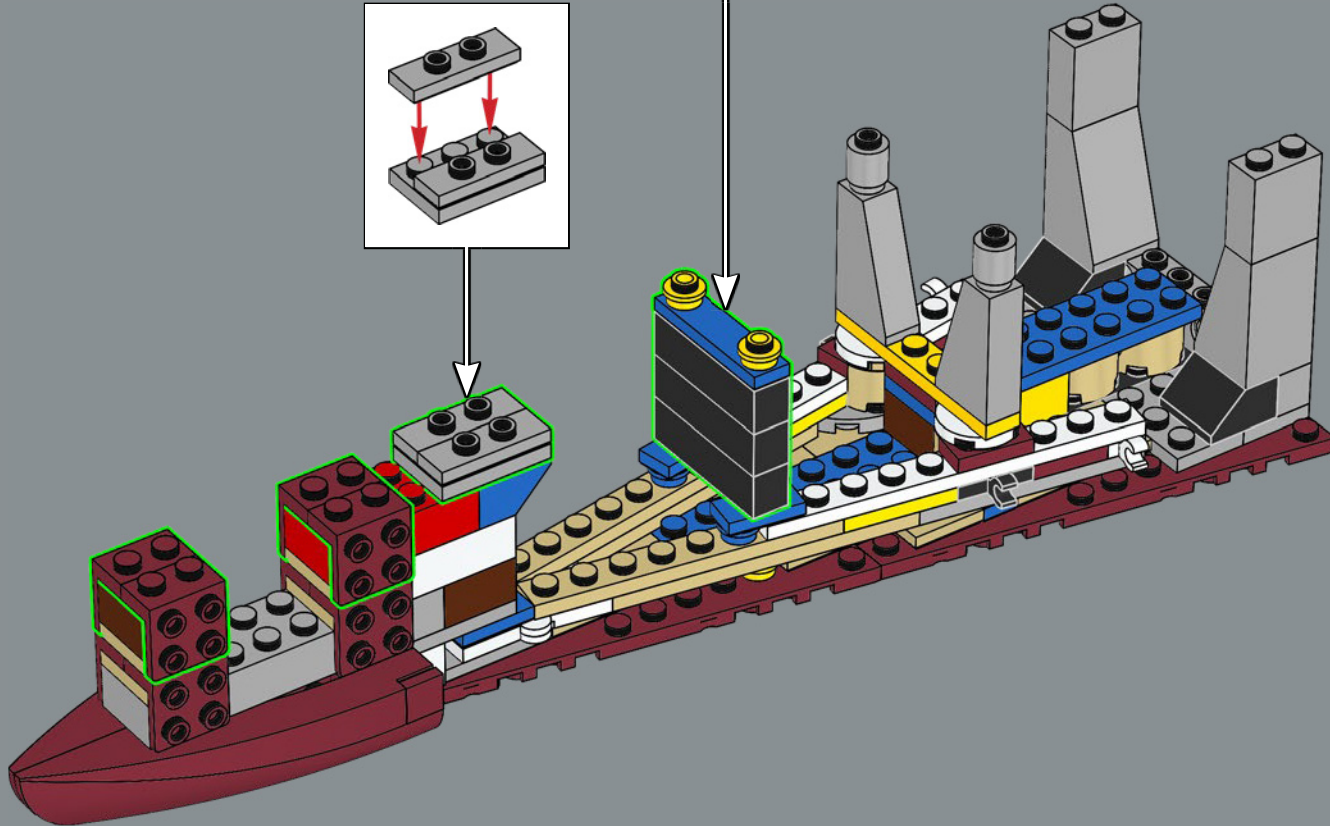
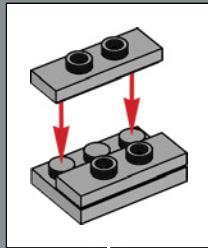
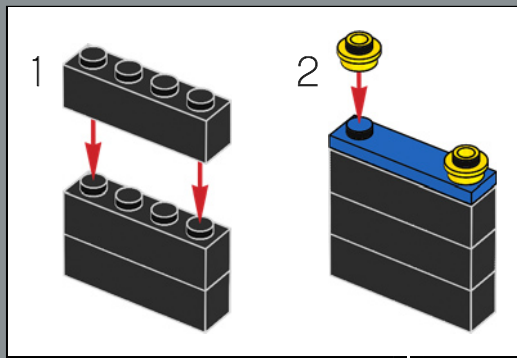

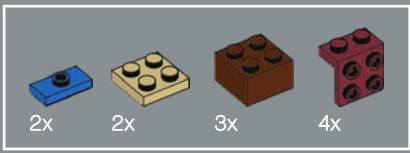

19

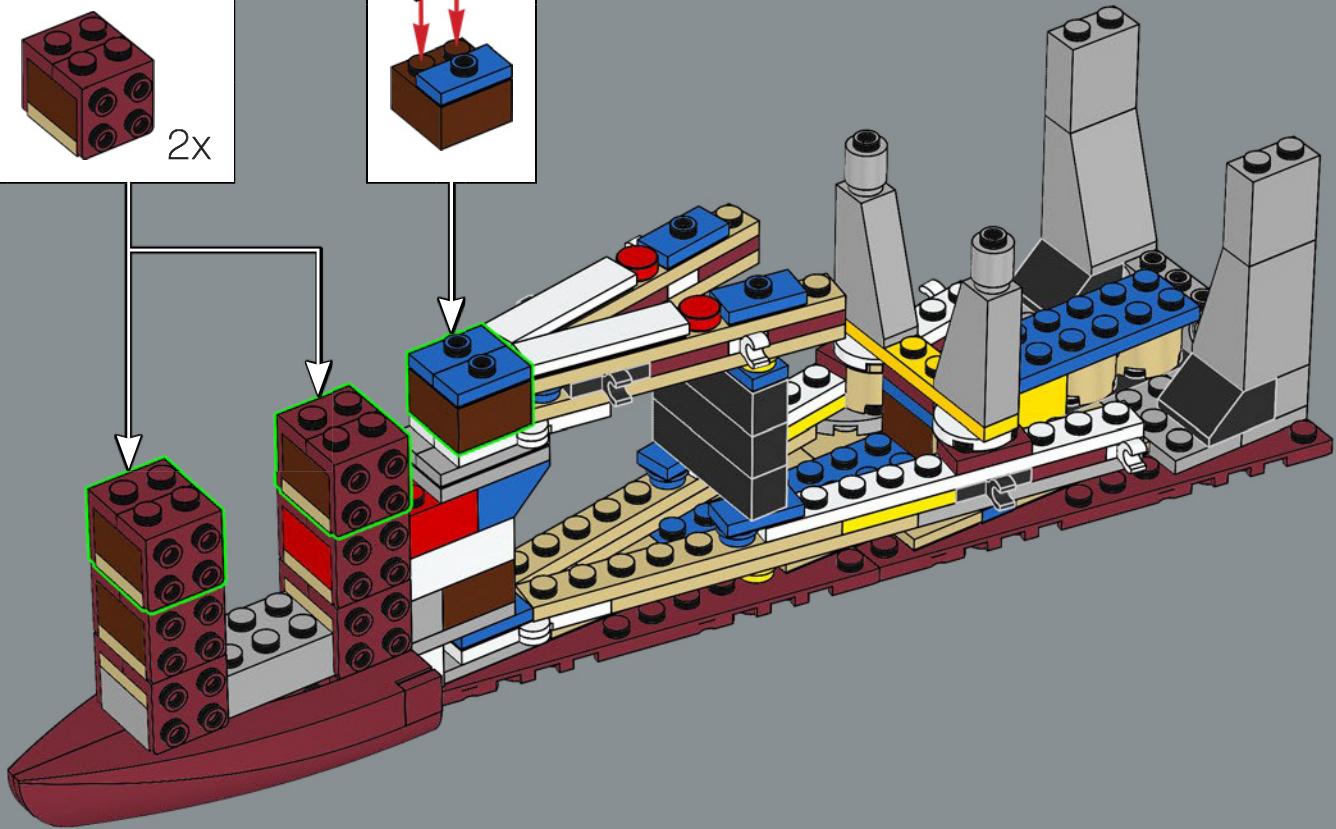
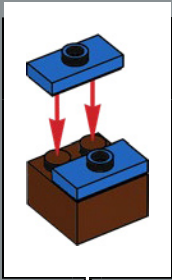
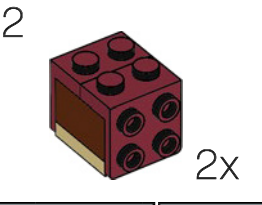
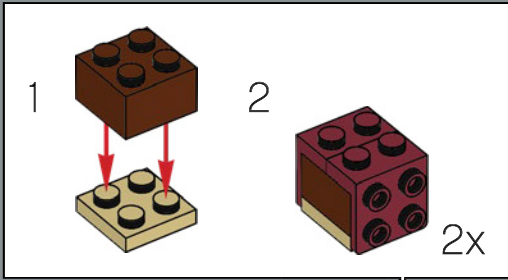

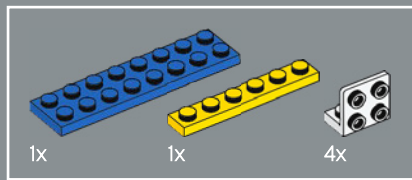

20

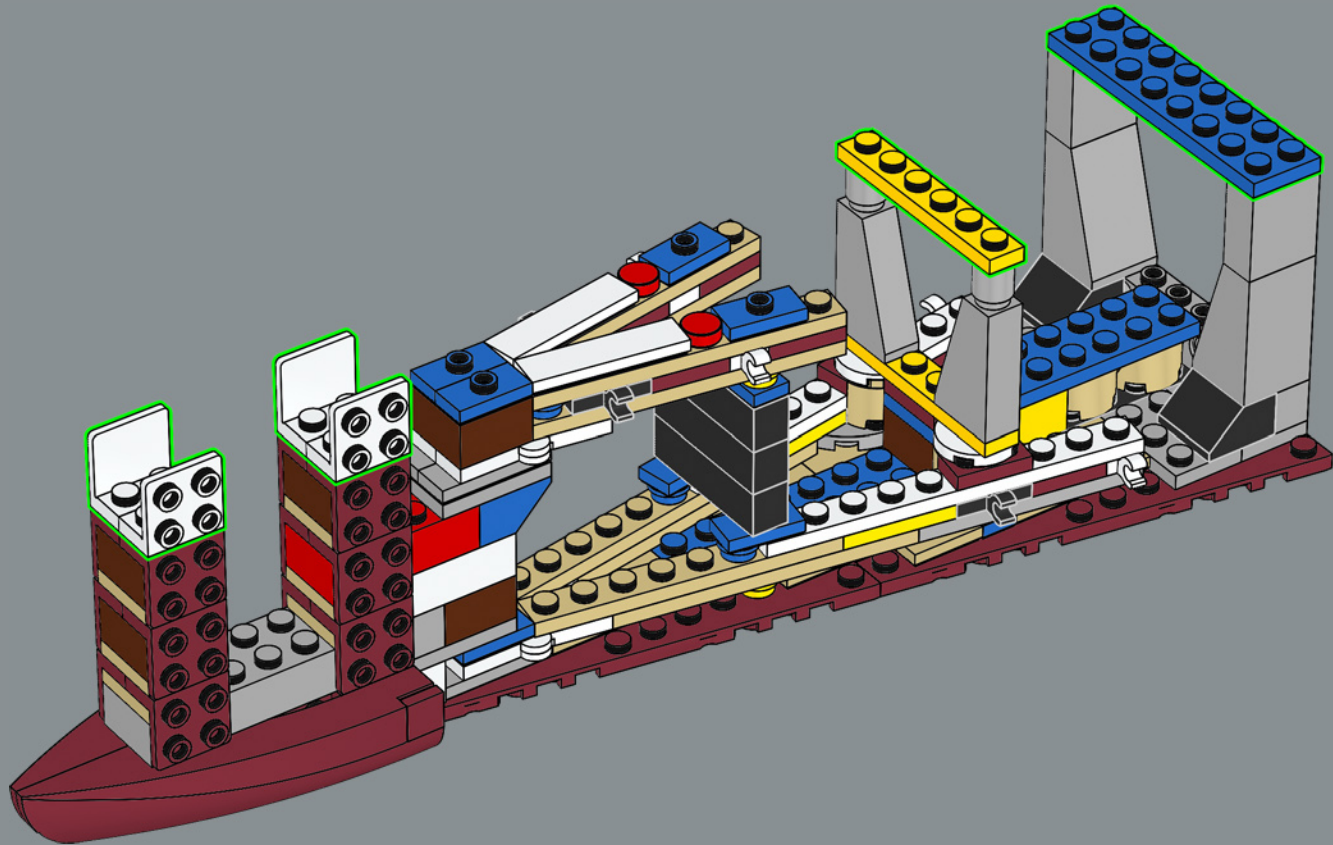

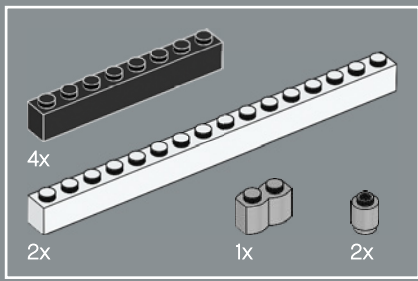

21

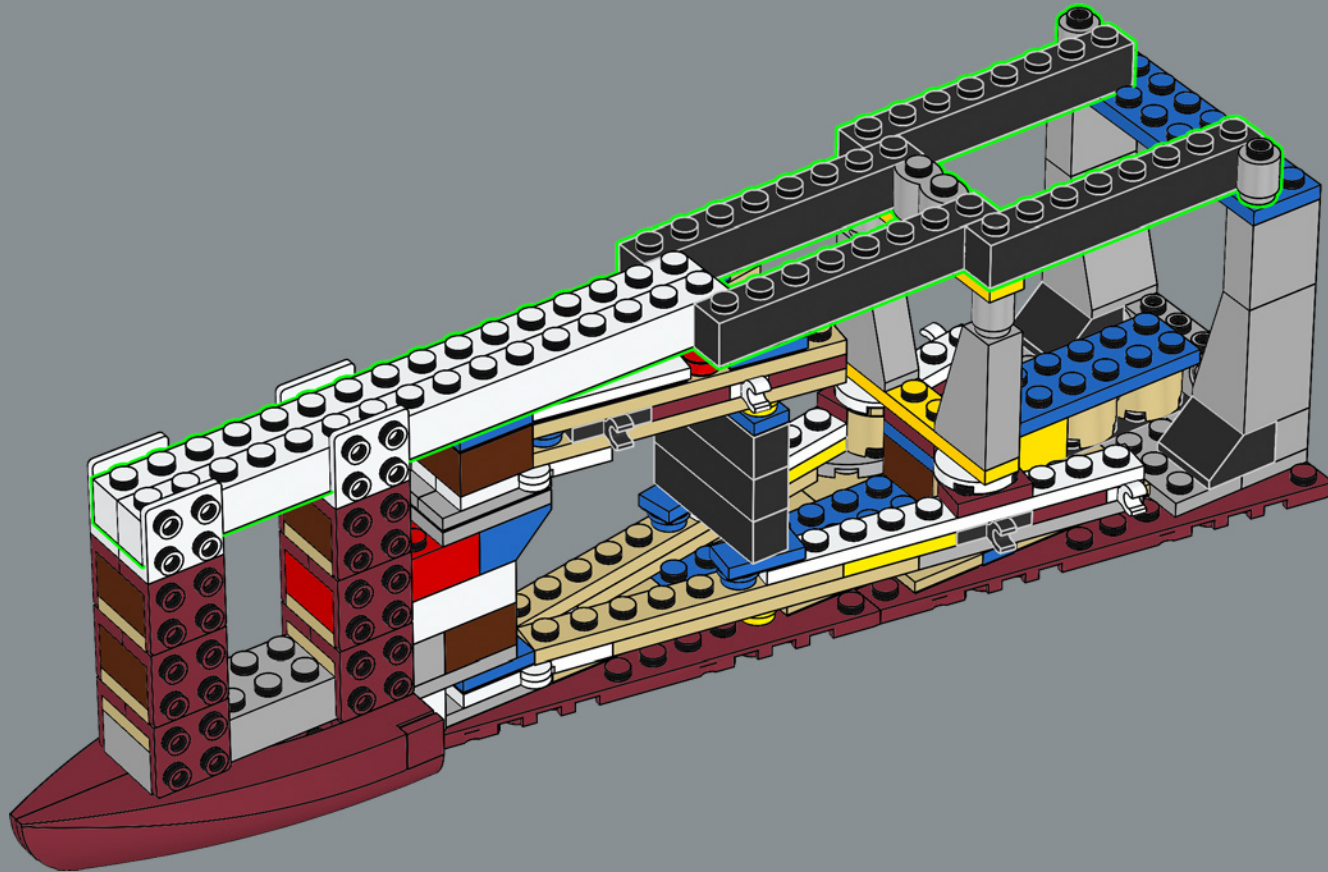

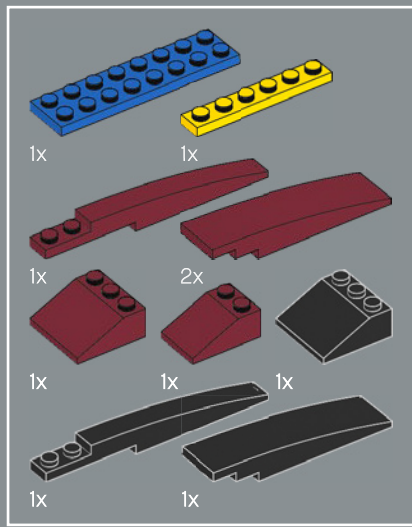

22

1

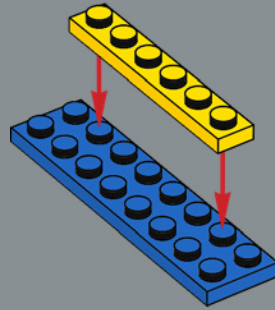

2

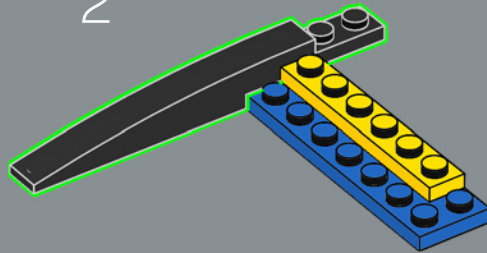

3

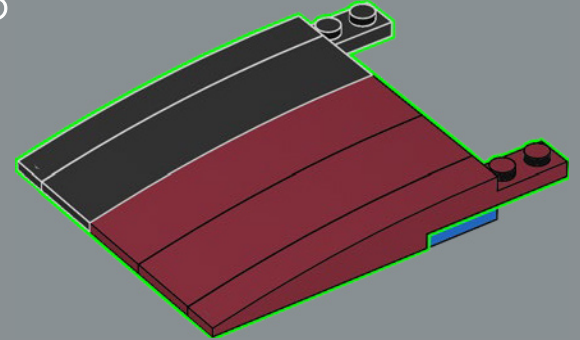

4

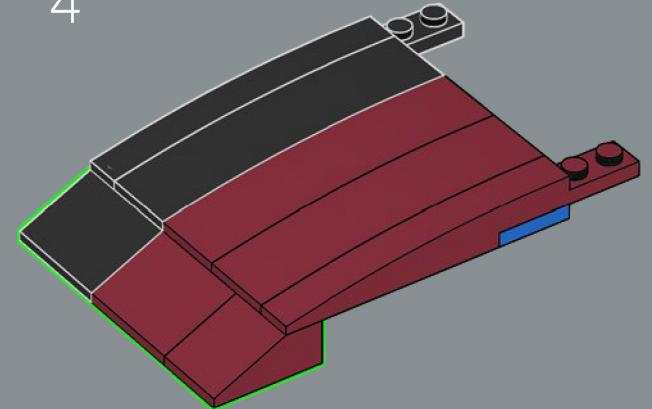

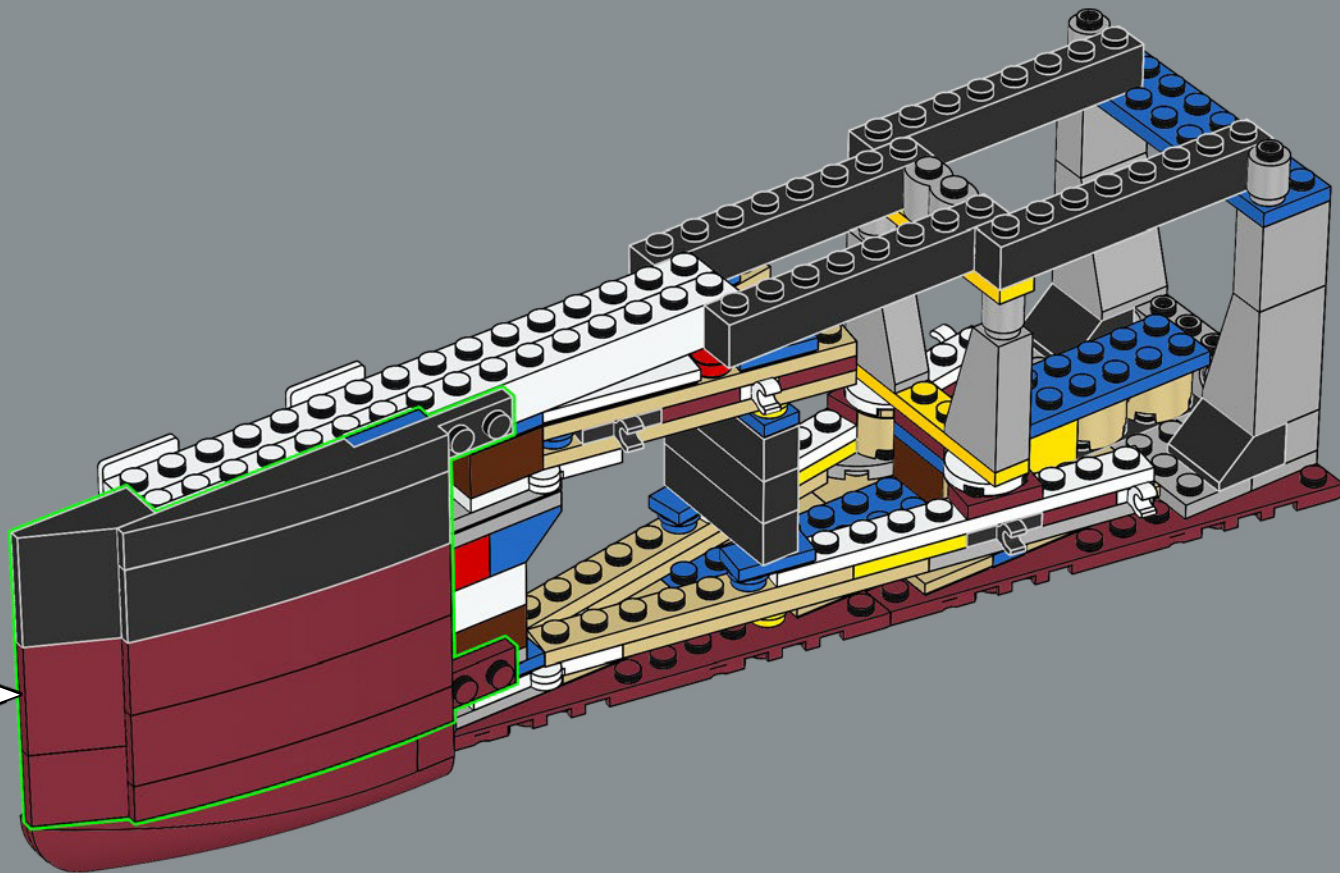

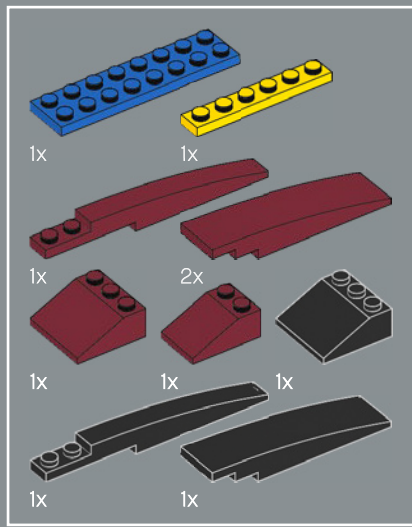

23

1

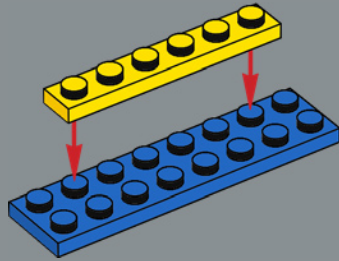

2

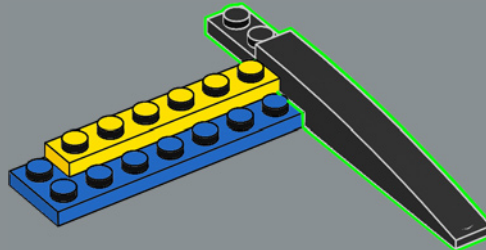

3

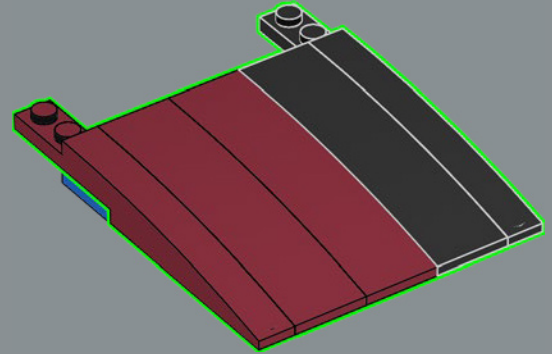

4

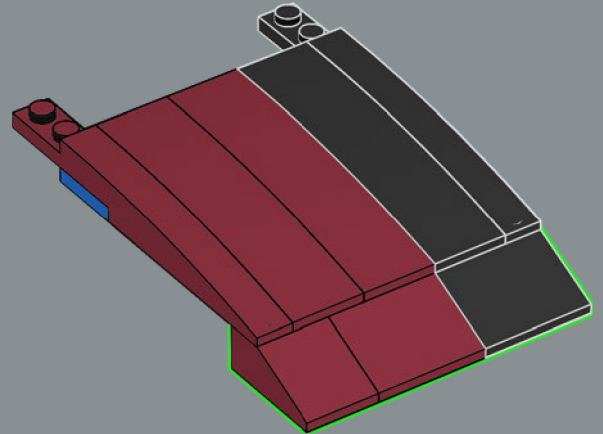

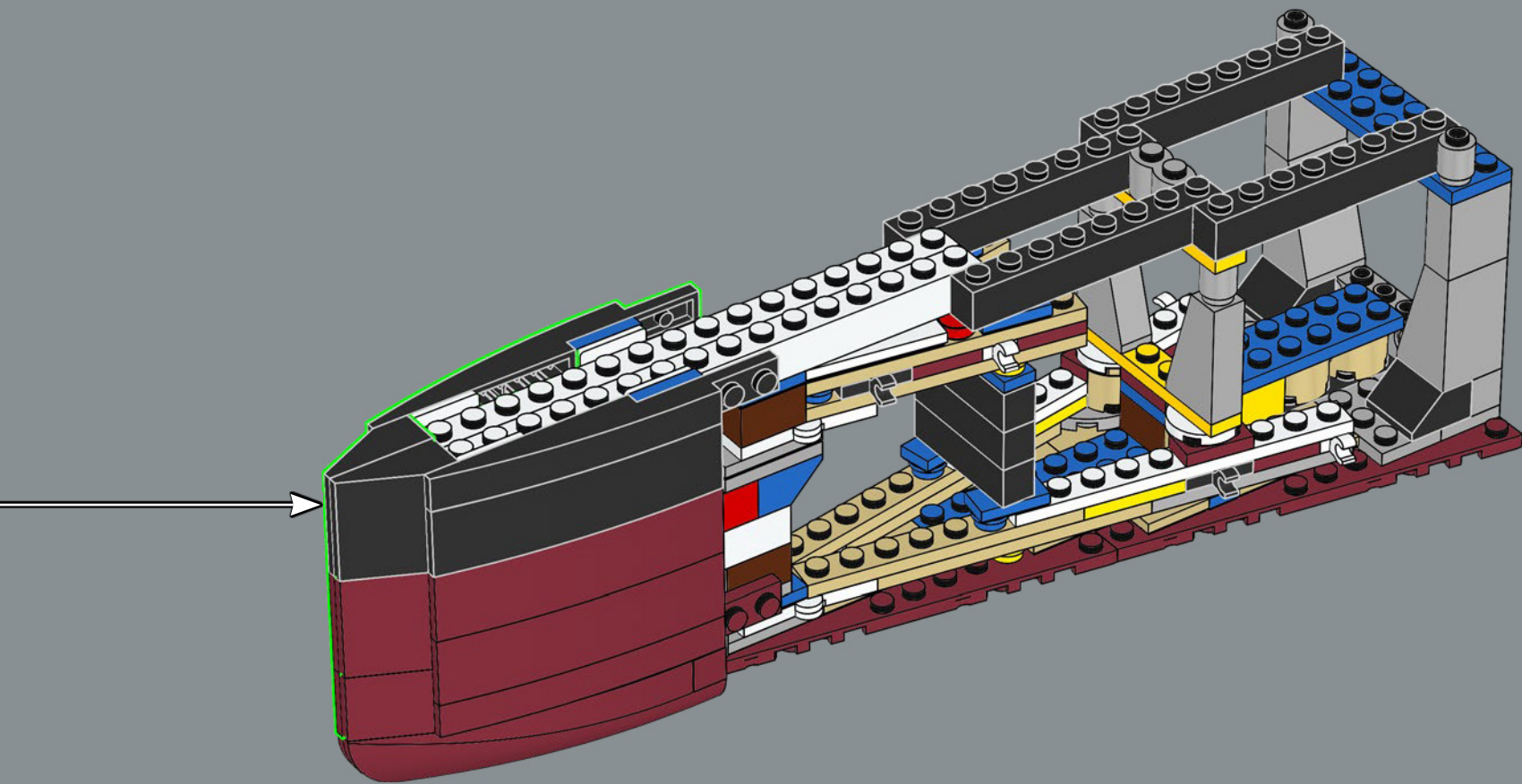

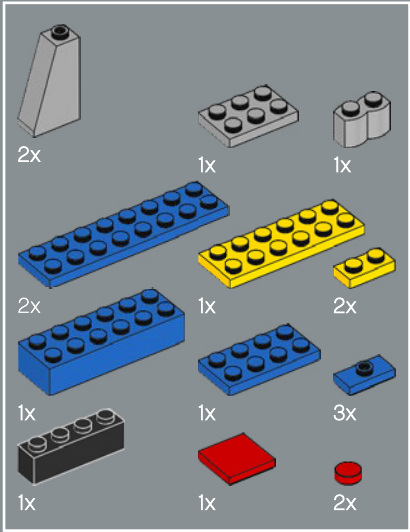
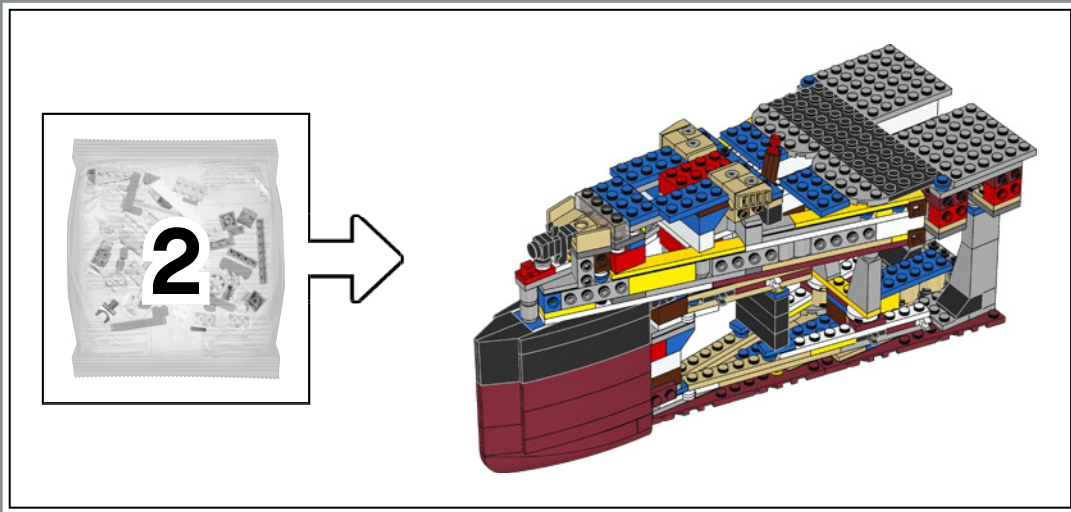

24

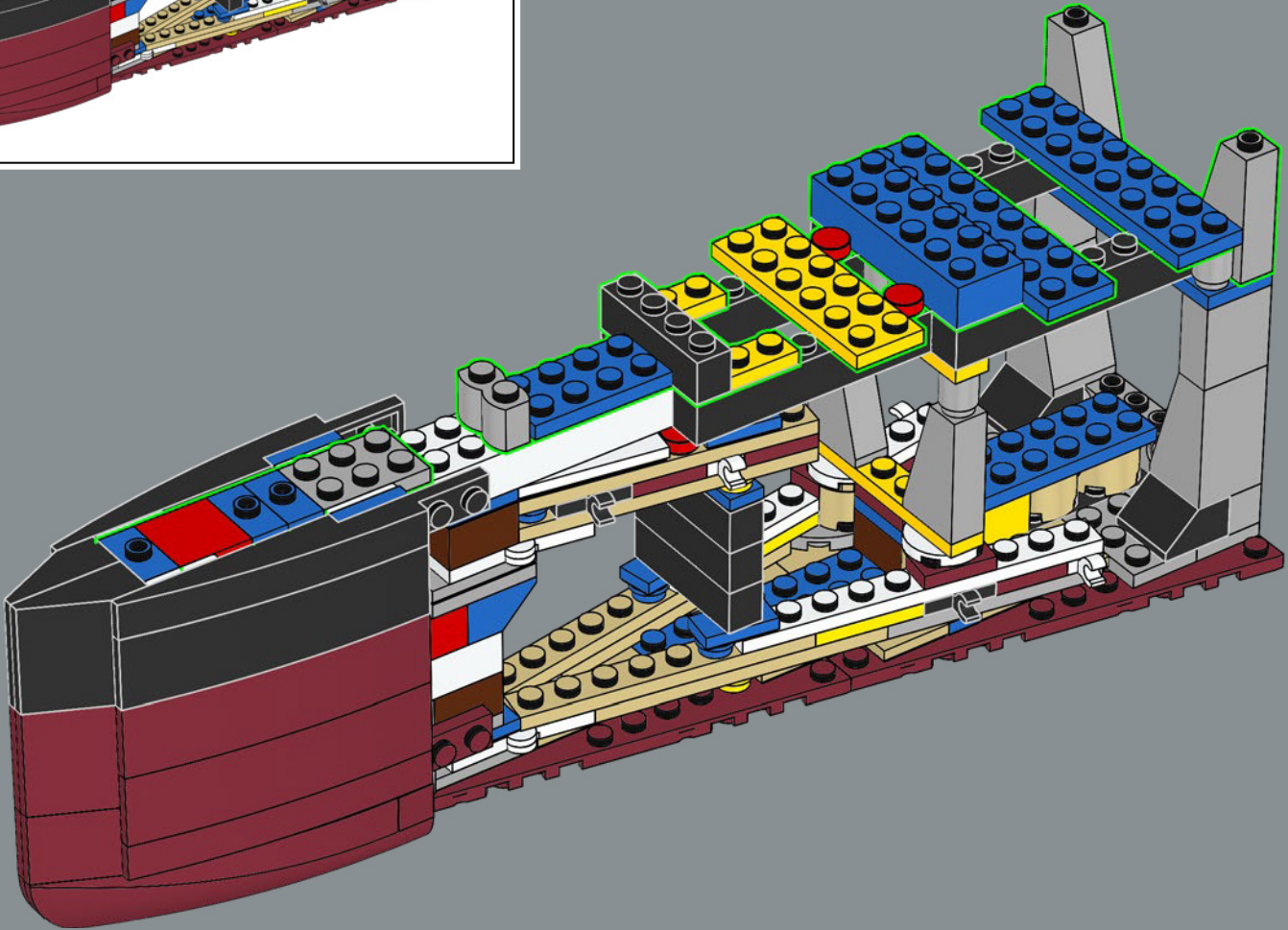

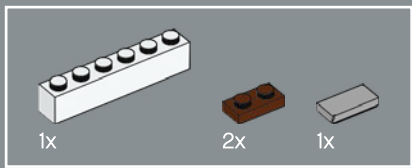

25

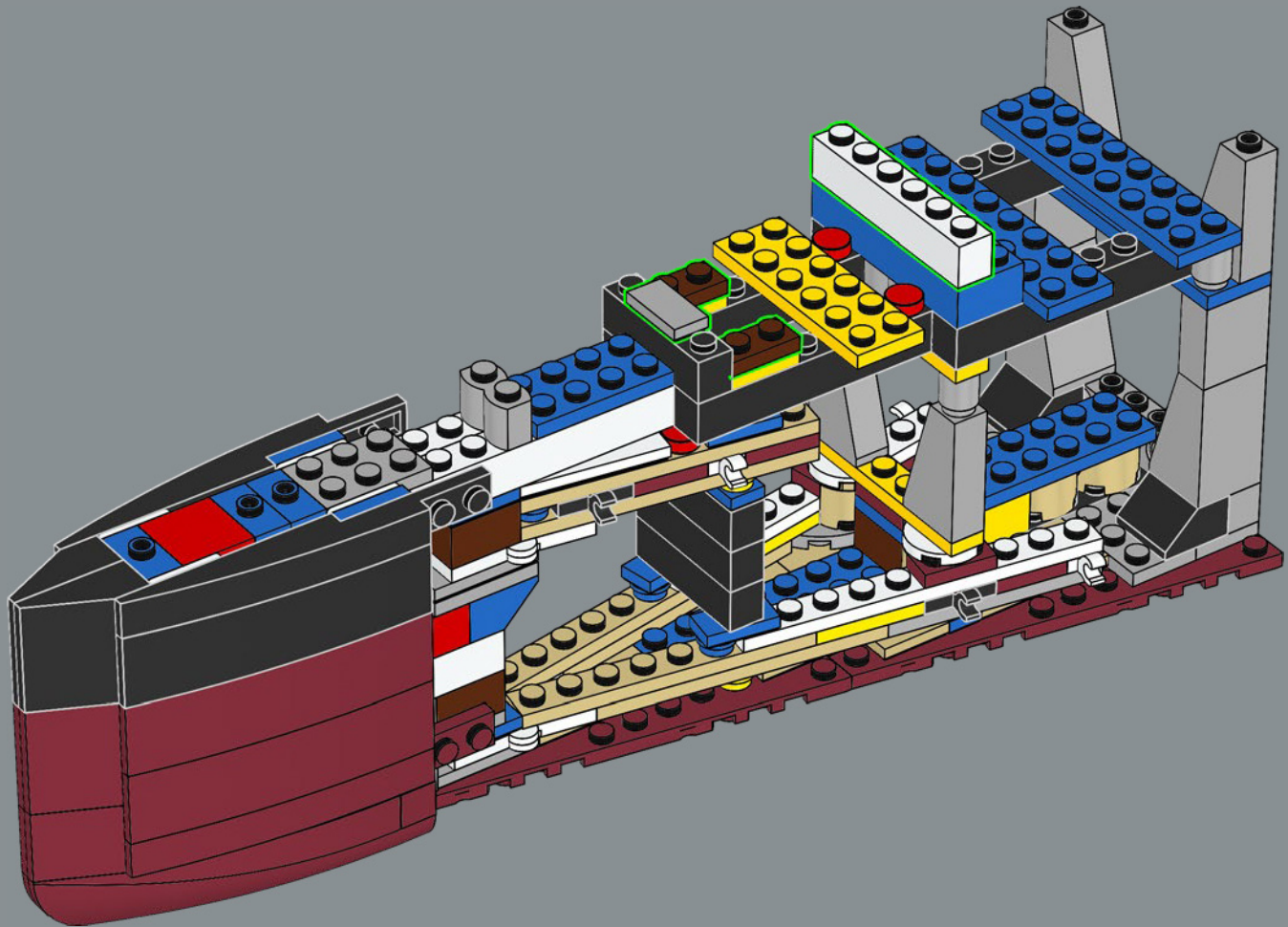

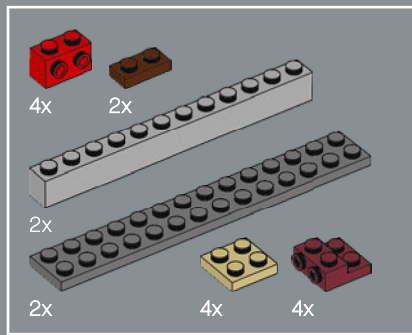

26

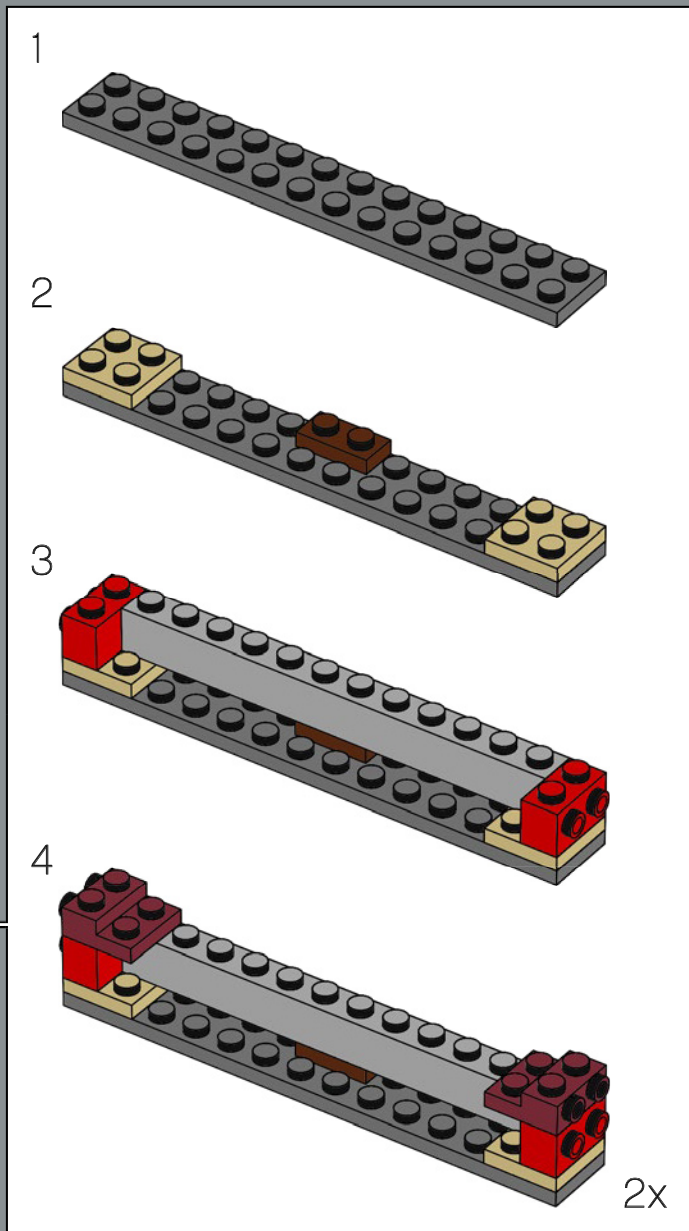
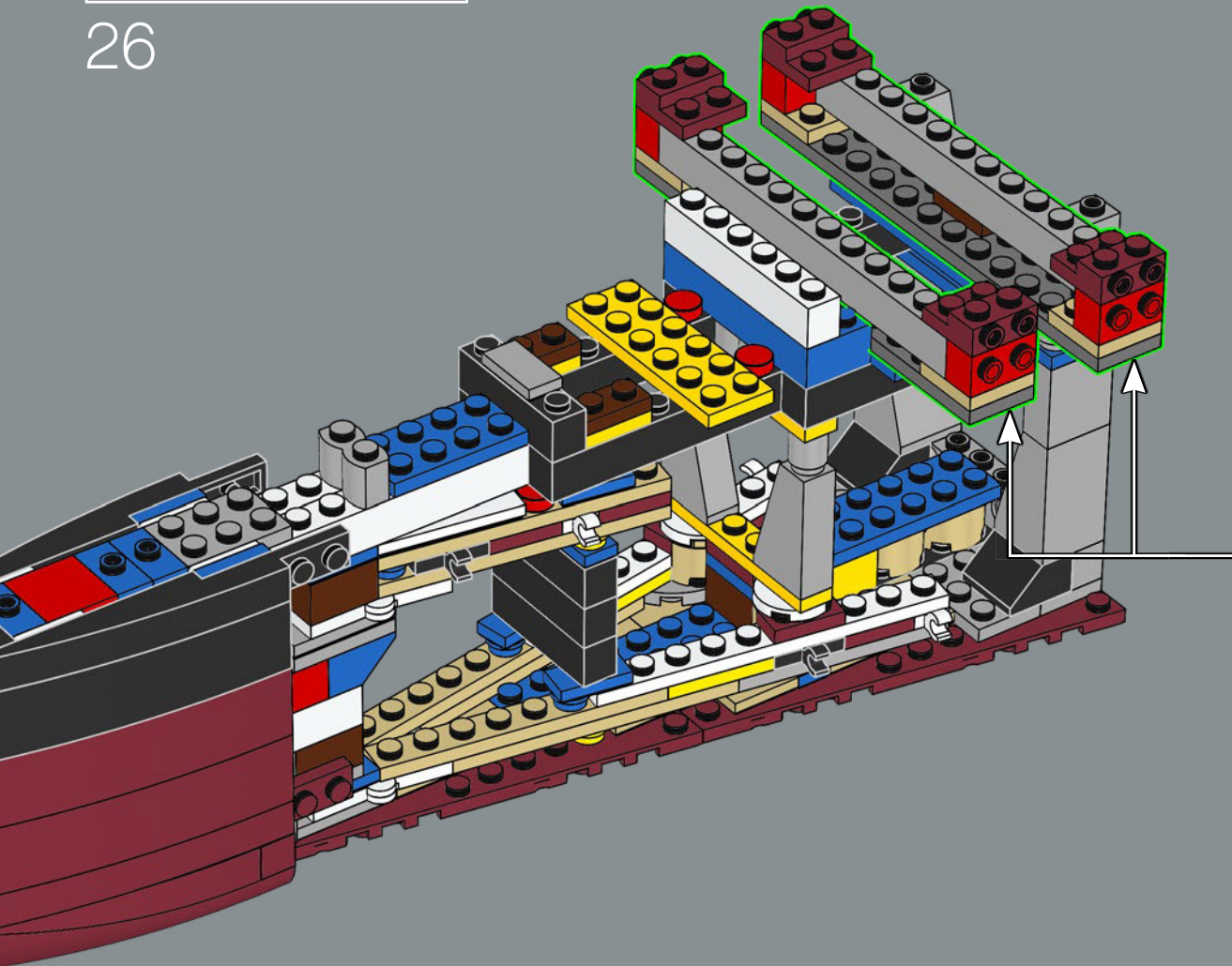

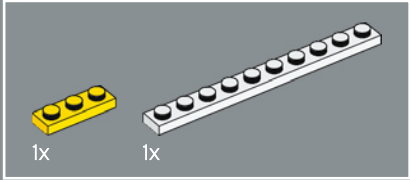
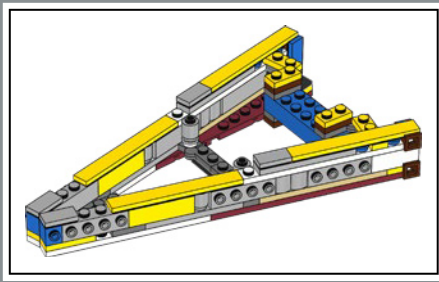

27

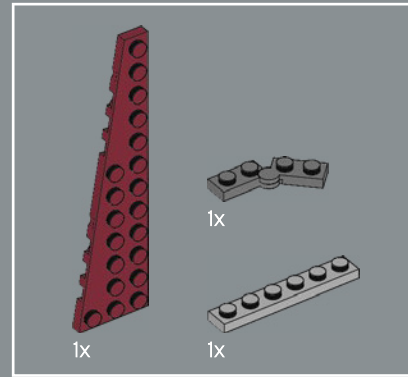
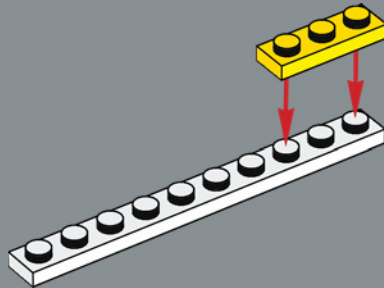

28

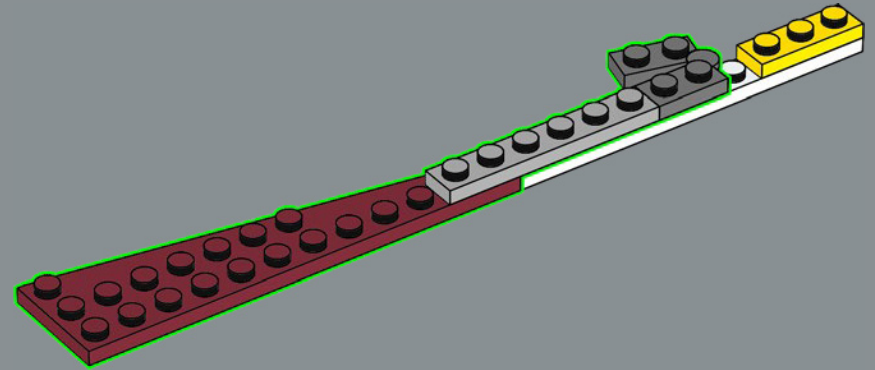

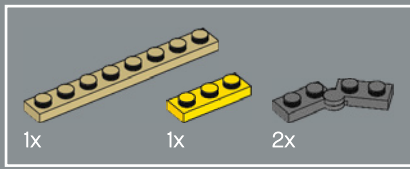

29

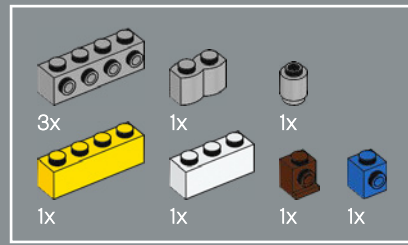
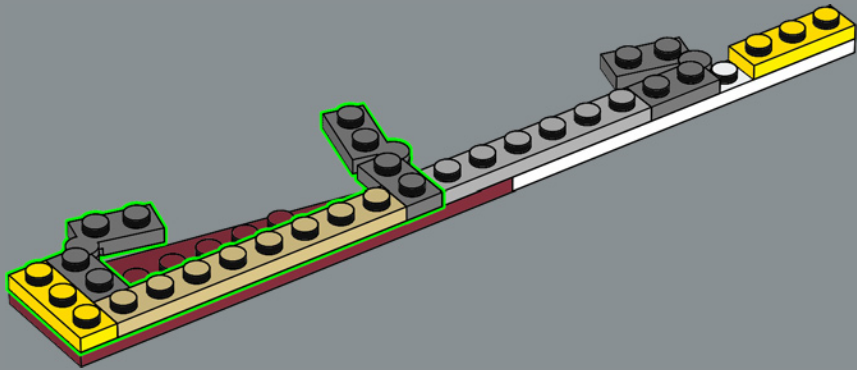

30

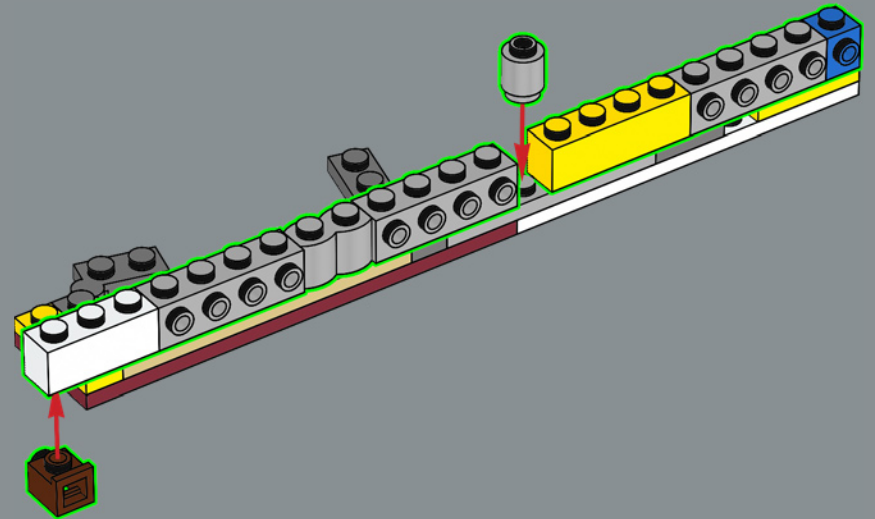

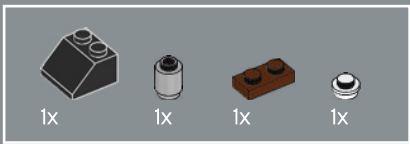

31

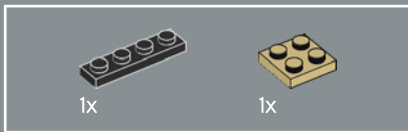
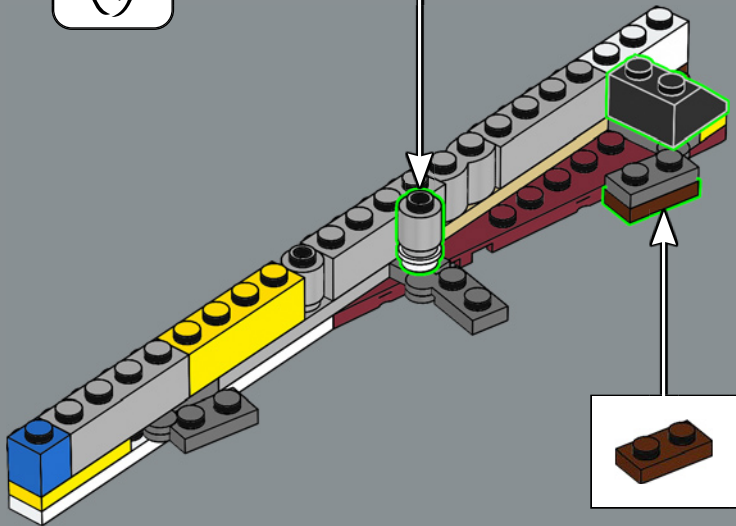
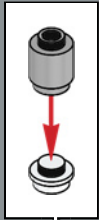

32

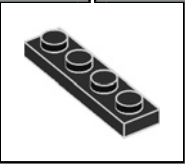
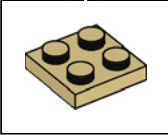
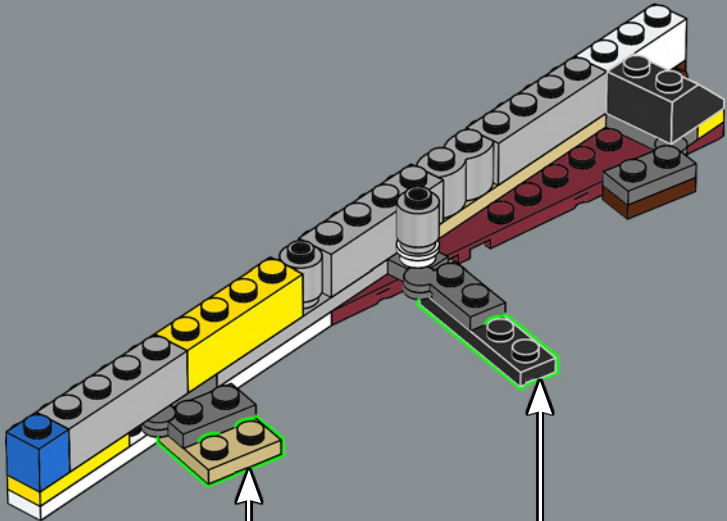

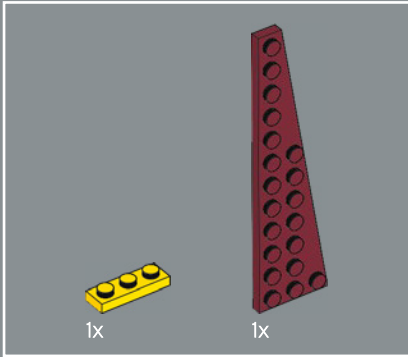
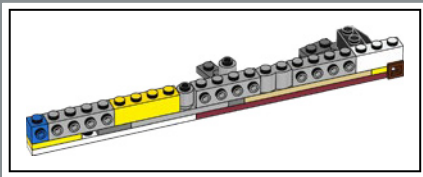

33

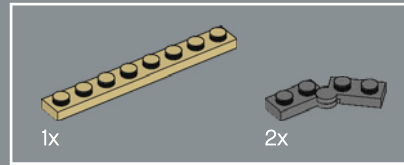
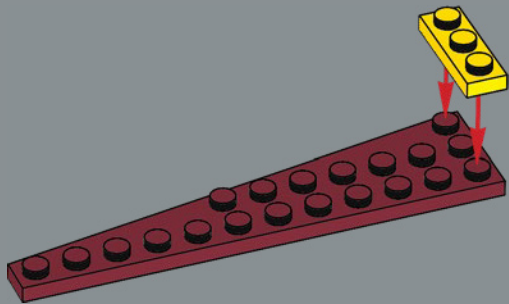

34

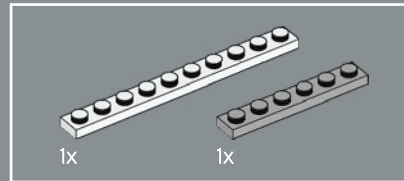
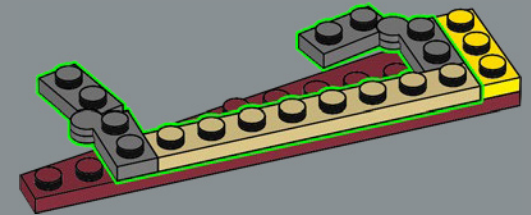

35

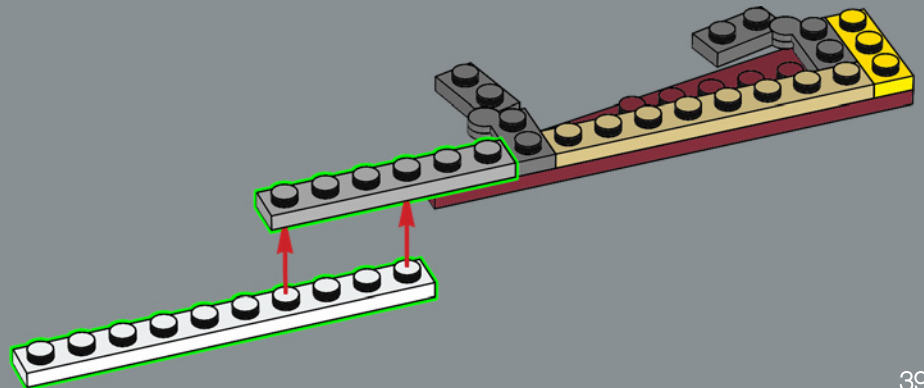

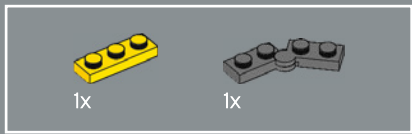

36

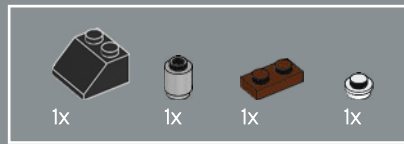
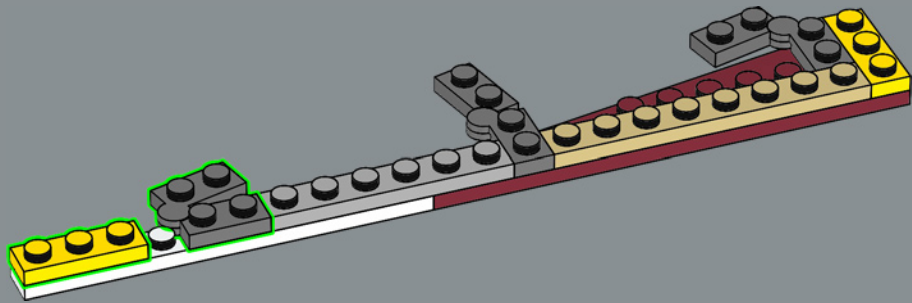

37

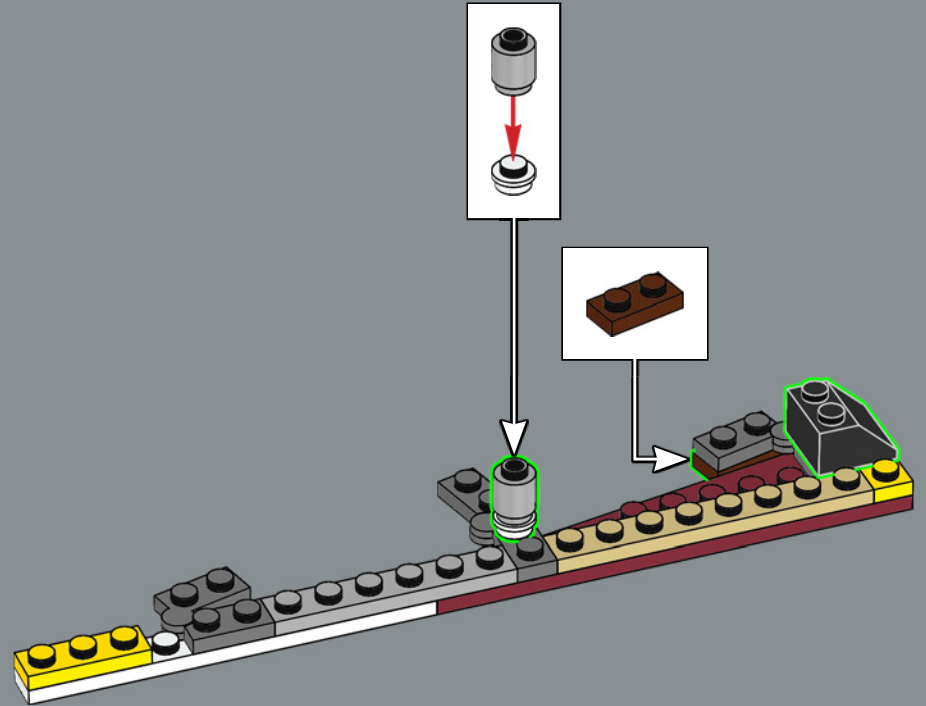

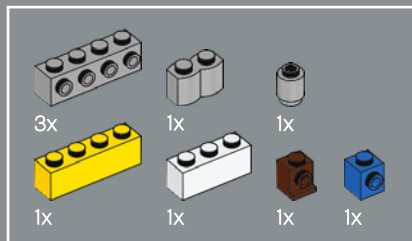

38

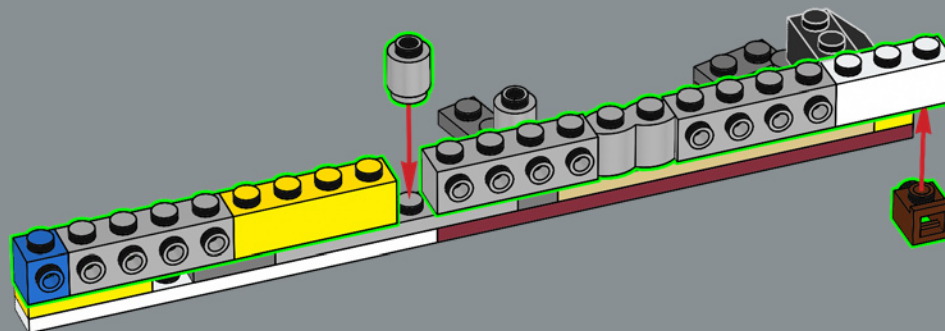

39

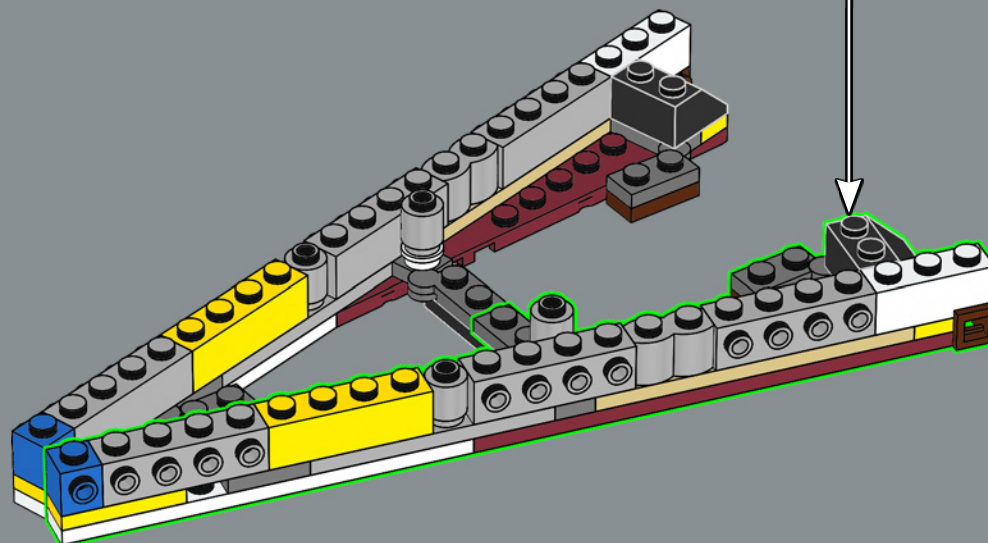

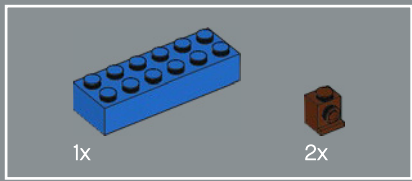

40

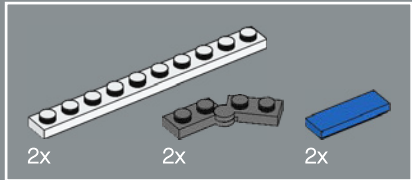
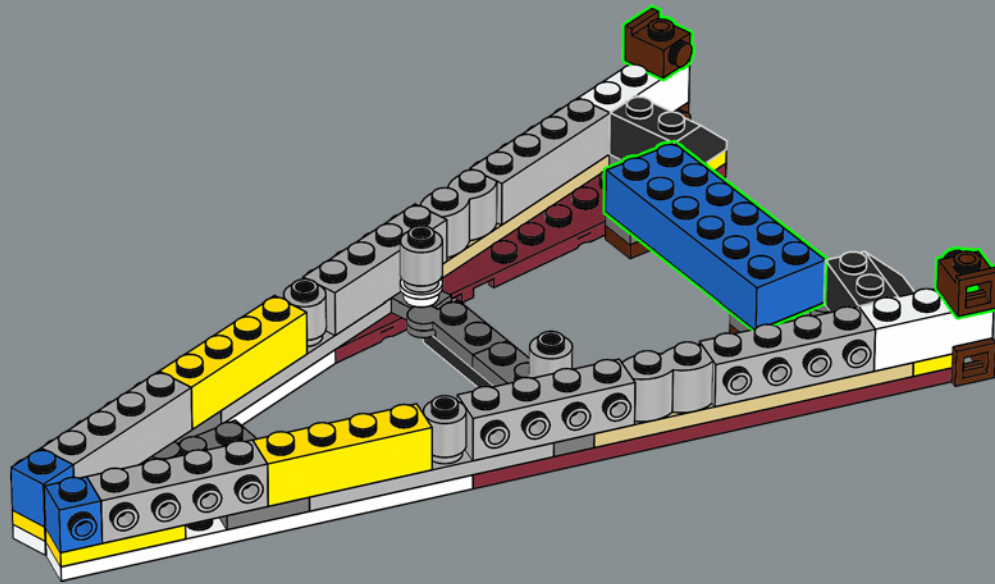

41

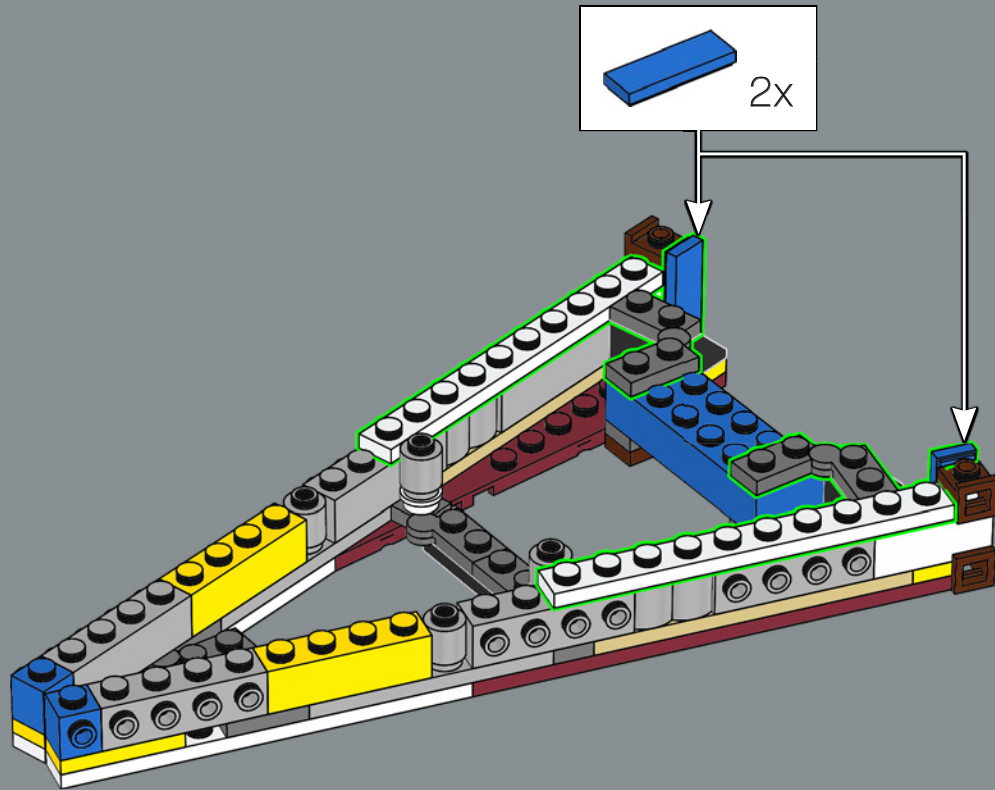

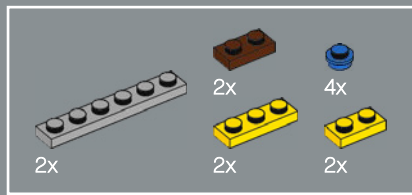

42

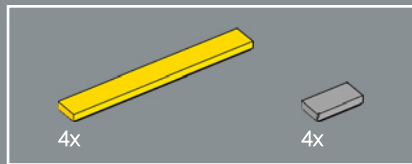
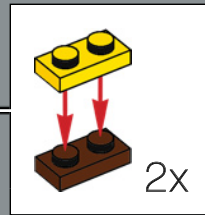
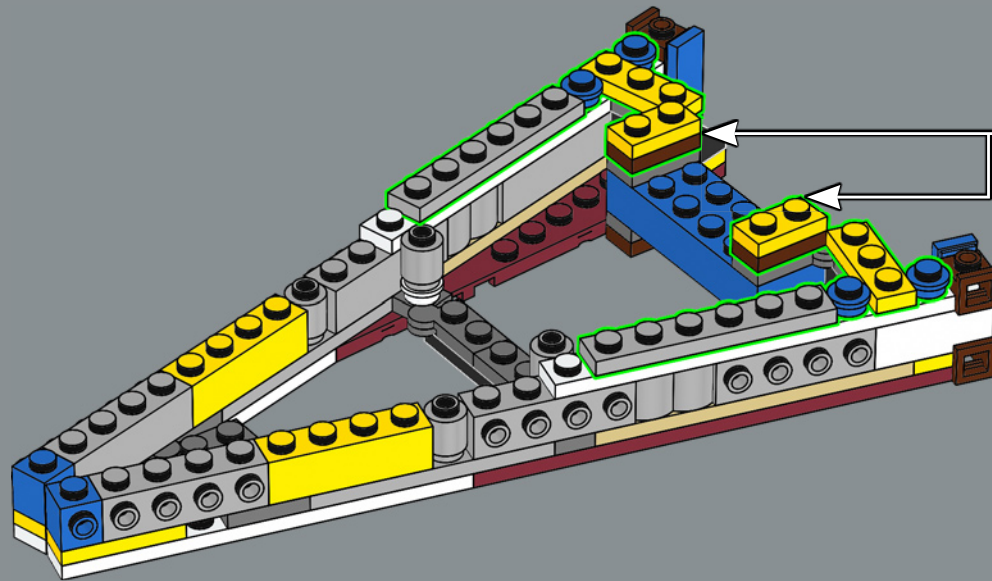

43

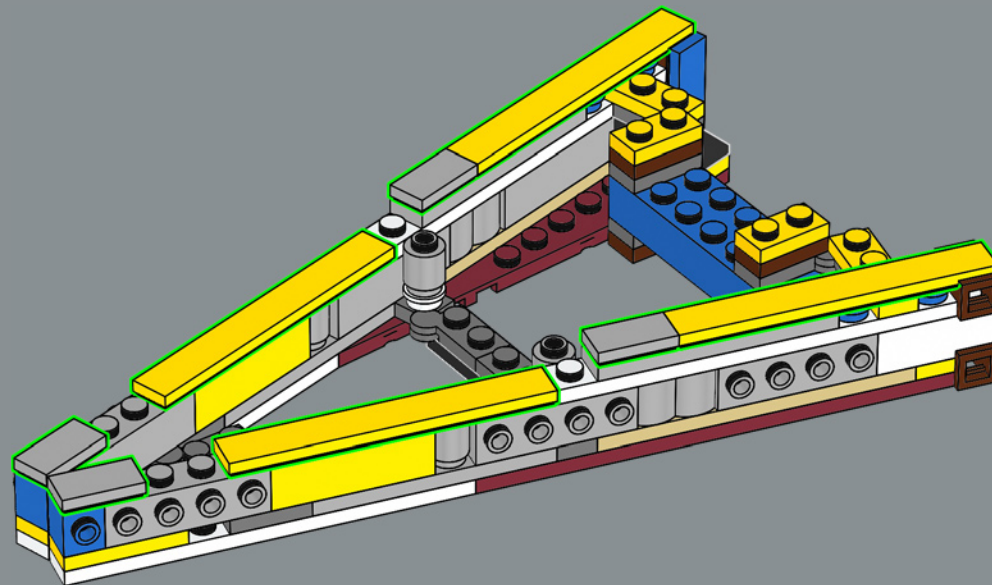

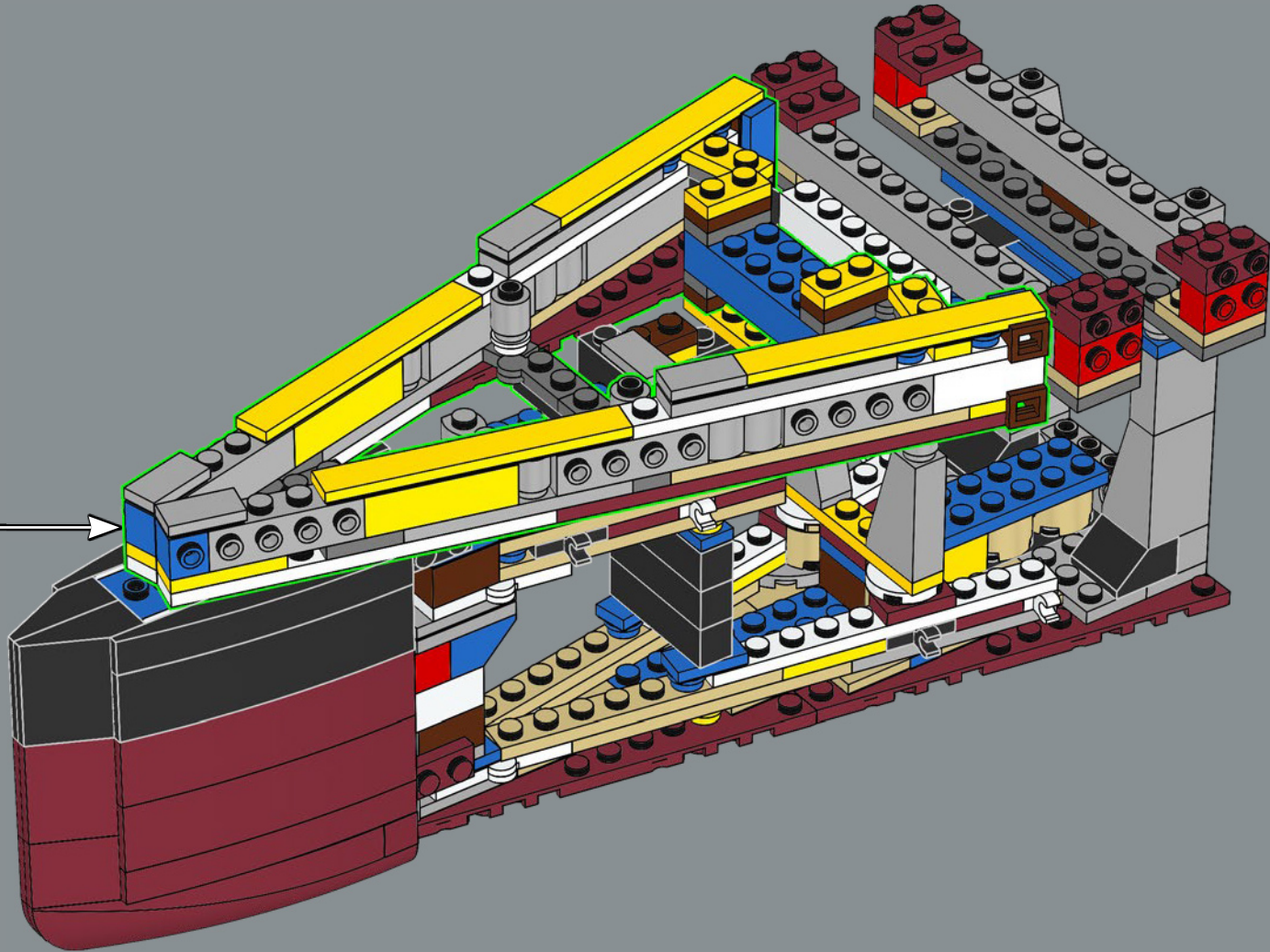

La costruzione dell'*Olympic* e del *Titanic* avvenne praticamente in parallelo. La costruzione di ciascuna delle navi necessitò di 26 mesi di lavoro.

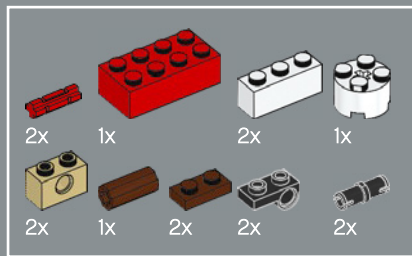

45

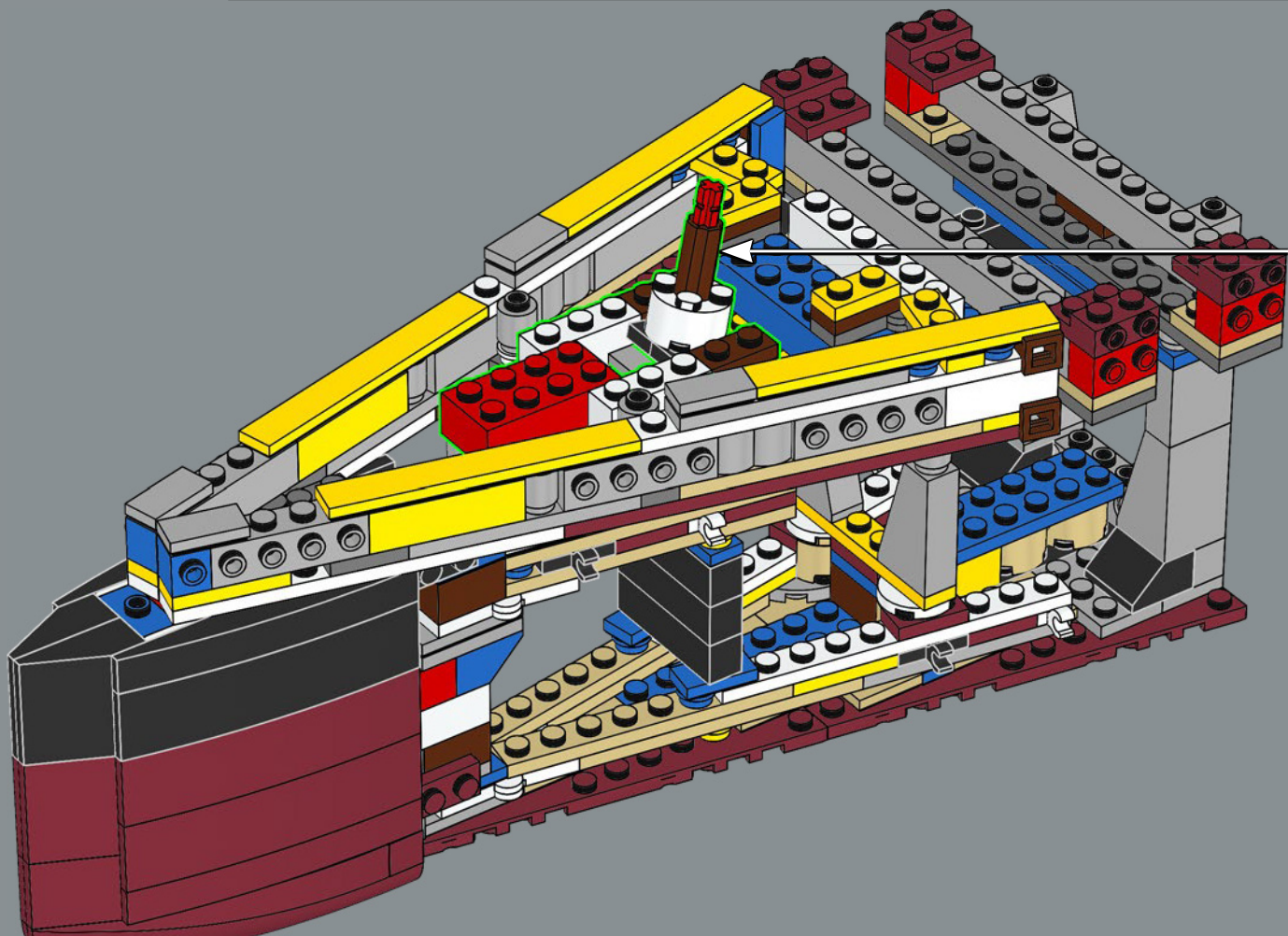
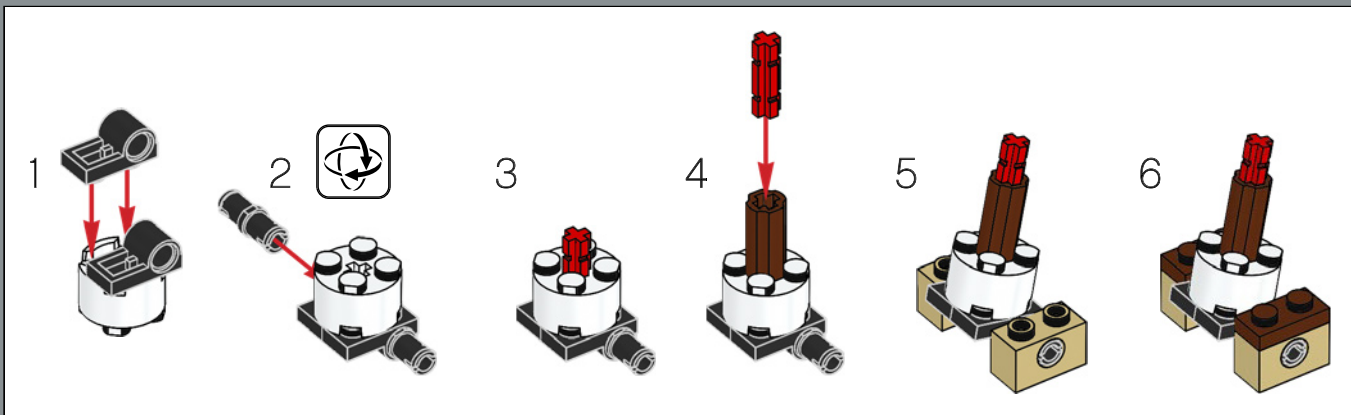

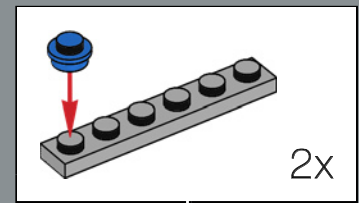
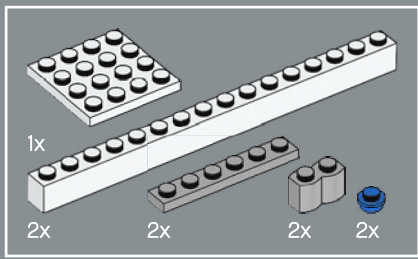

46

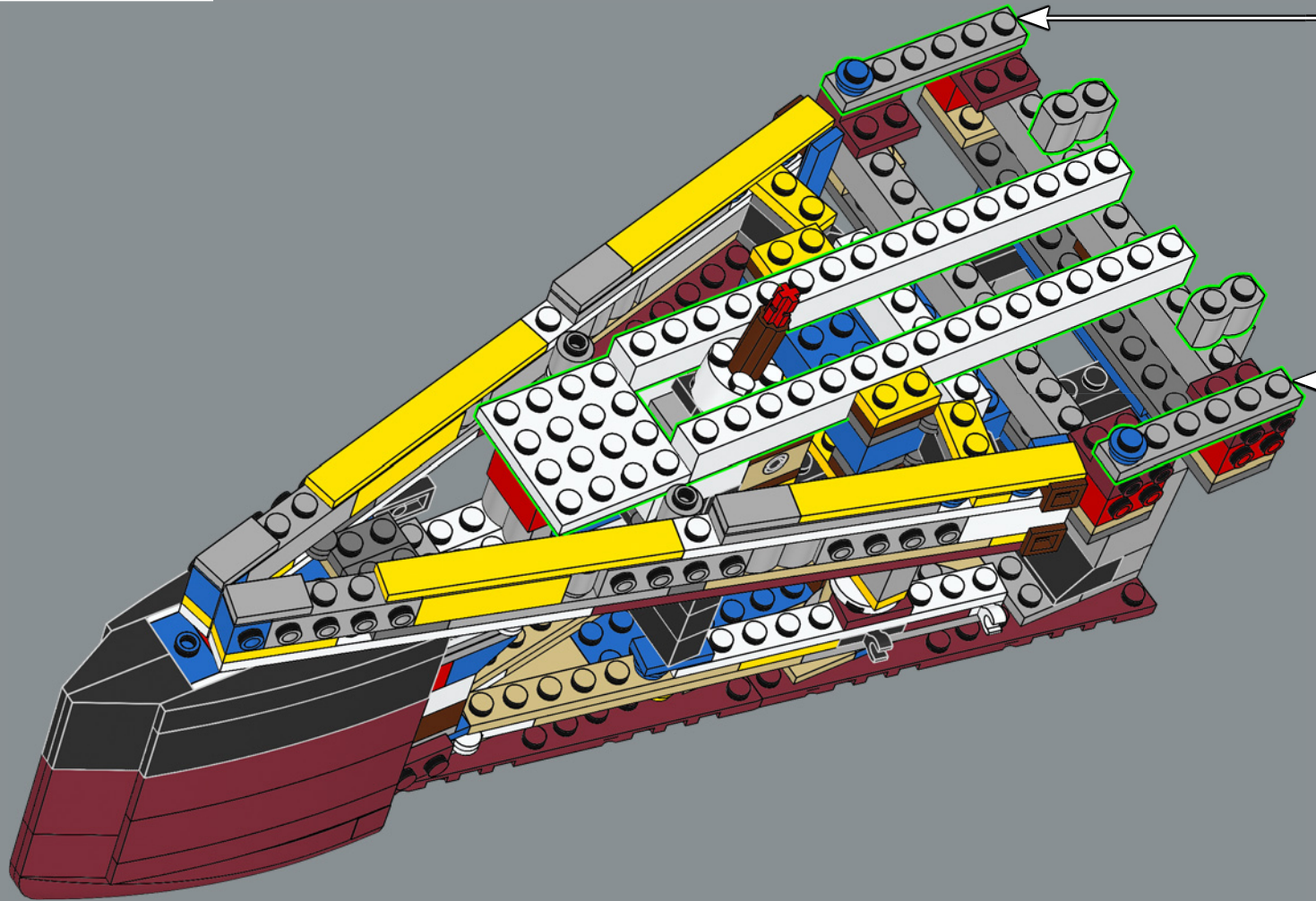

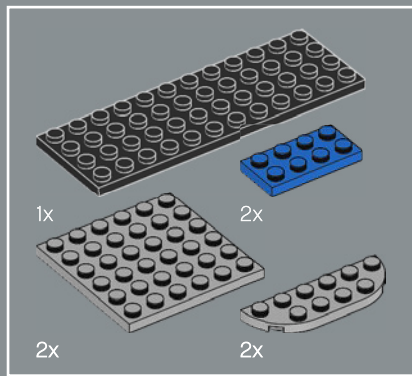

47

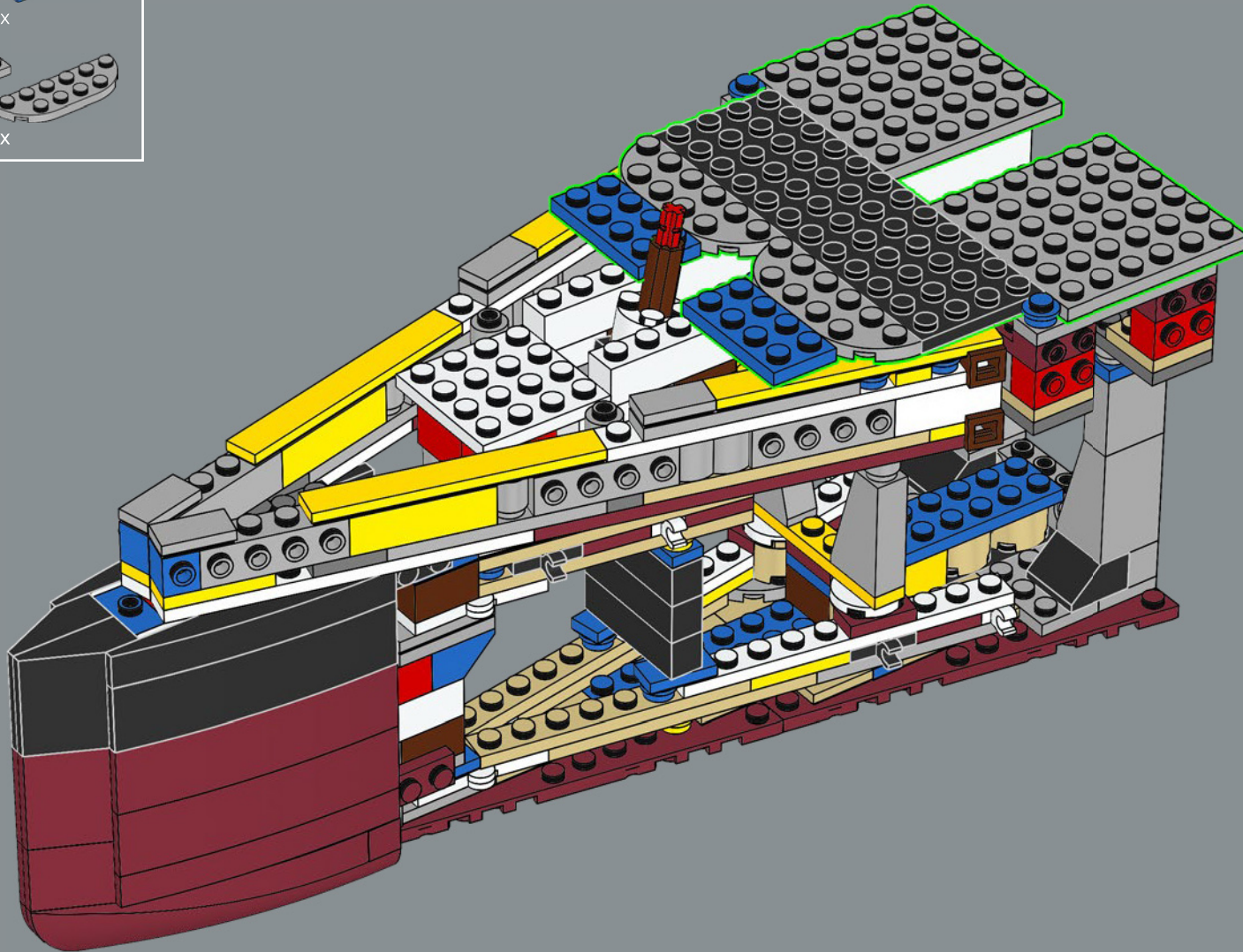

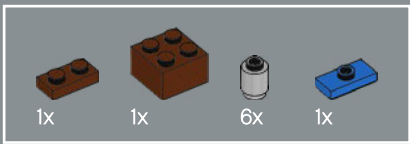

48

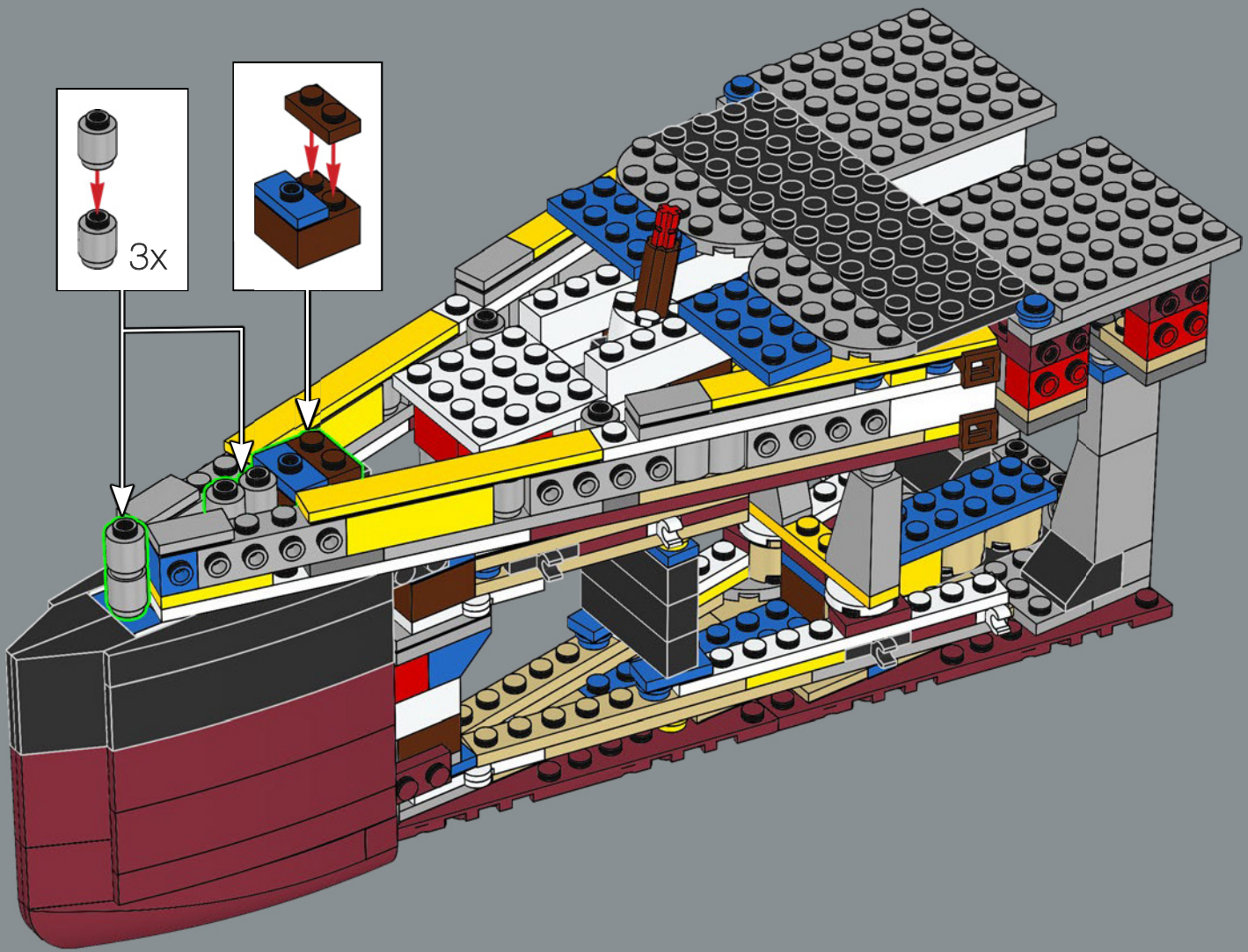

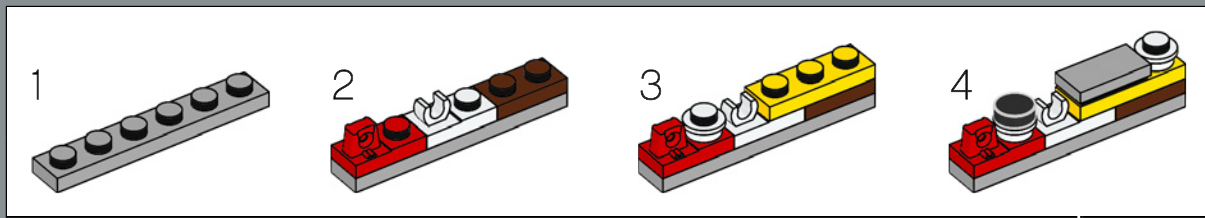
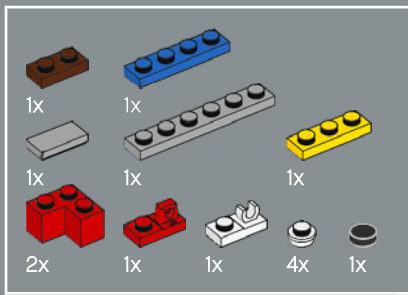

49

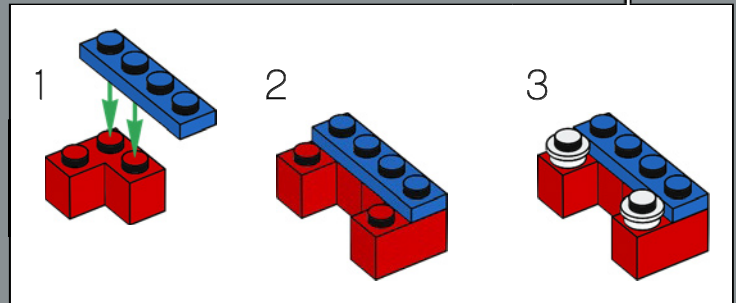
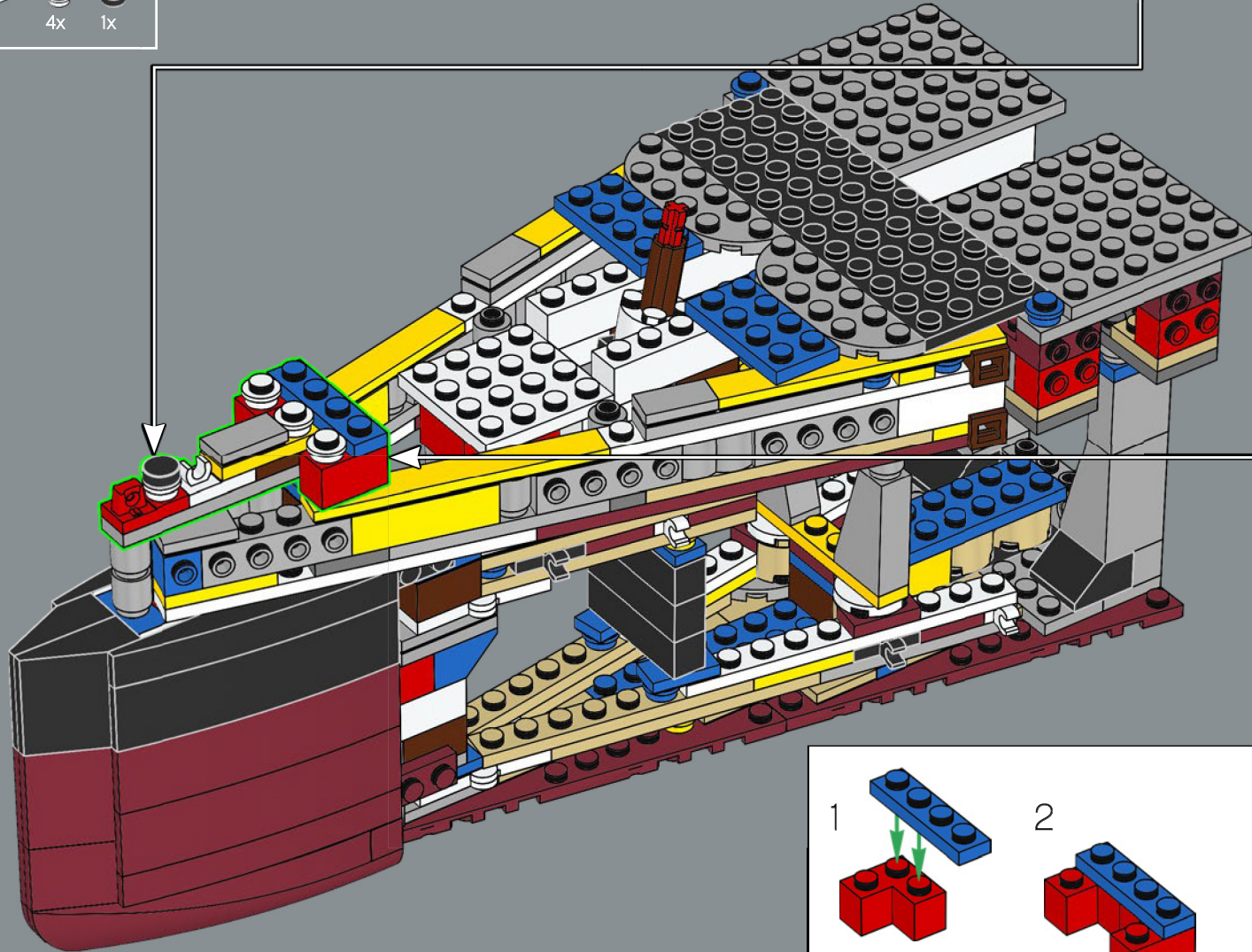

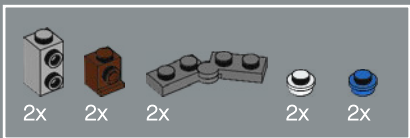

50

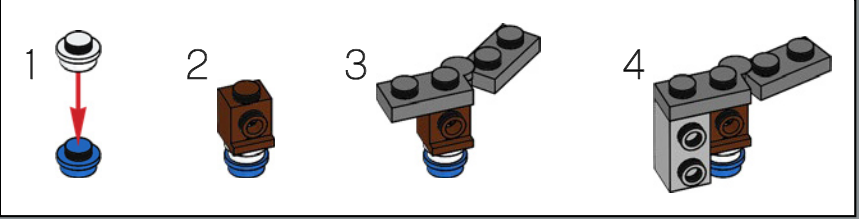
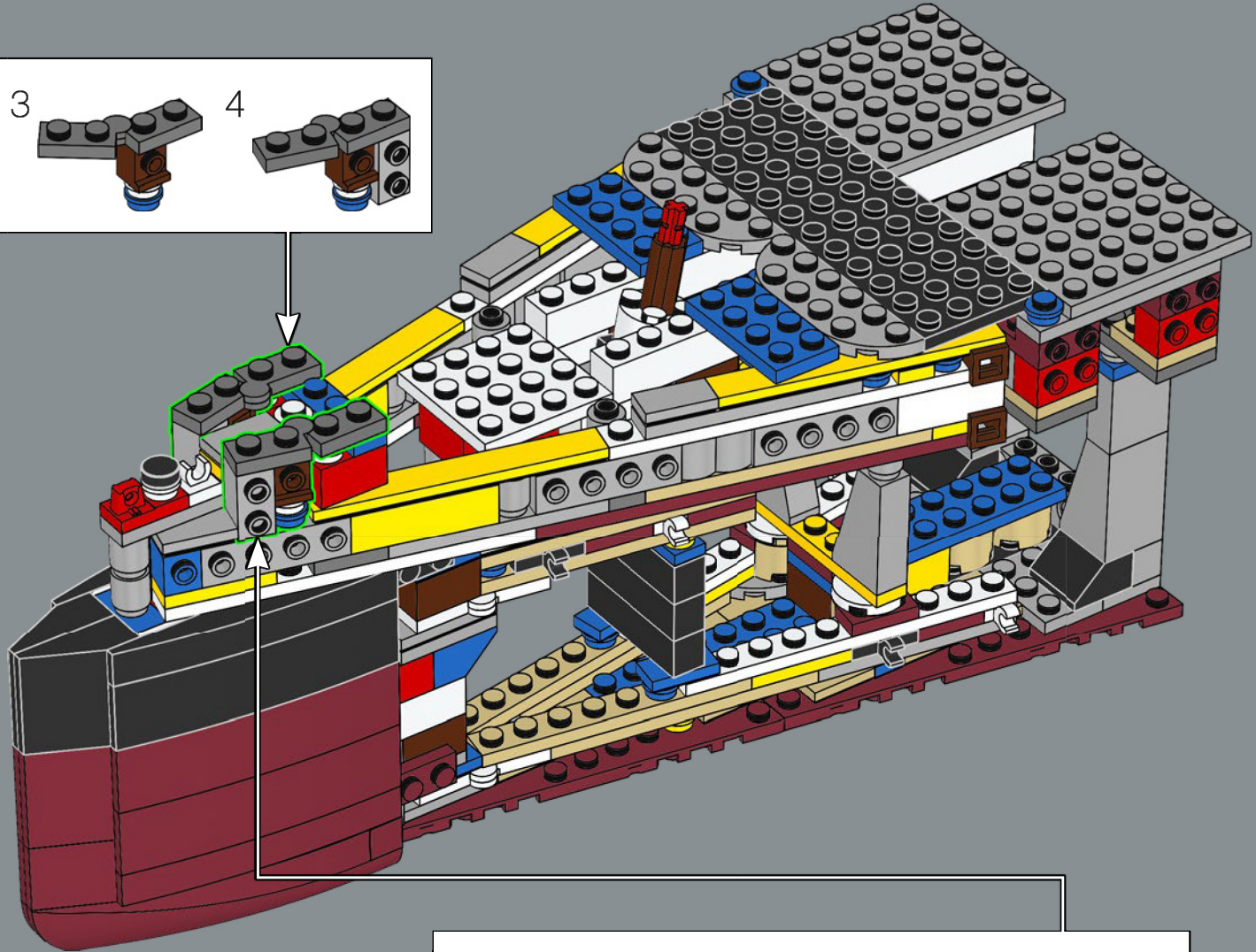
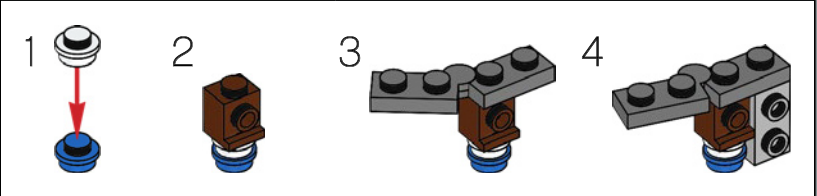

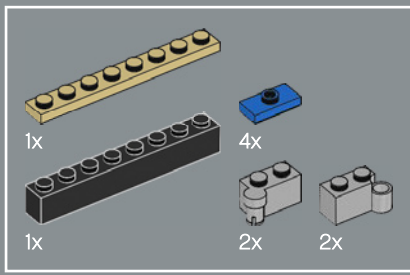

51

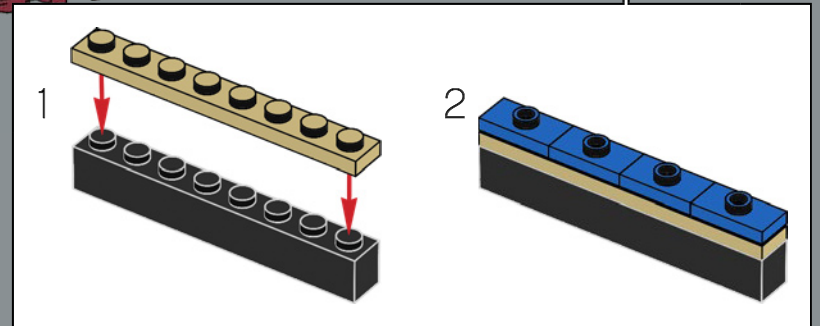
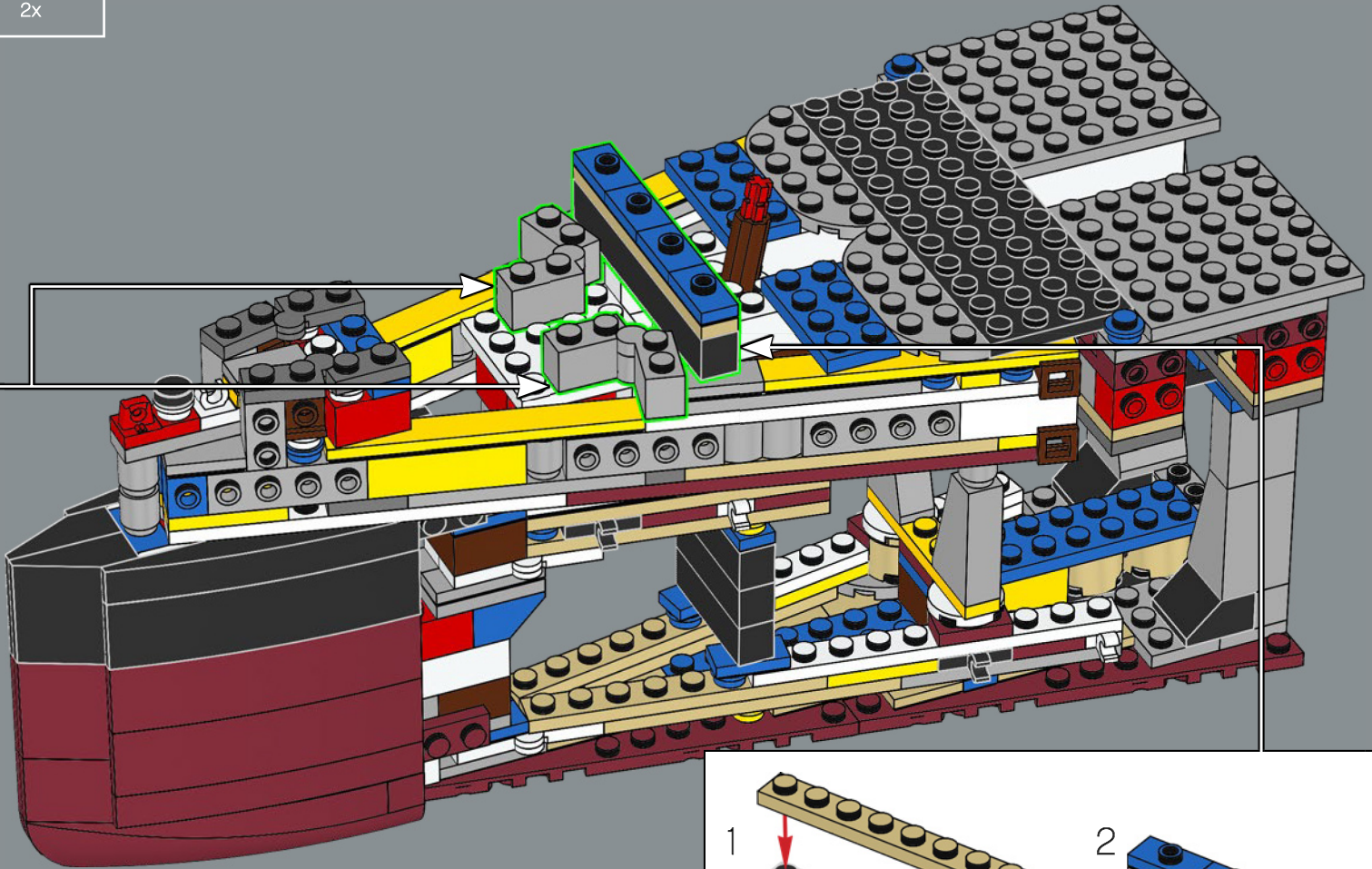
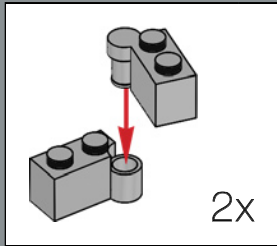

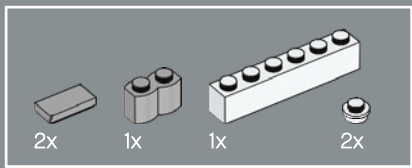

52

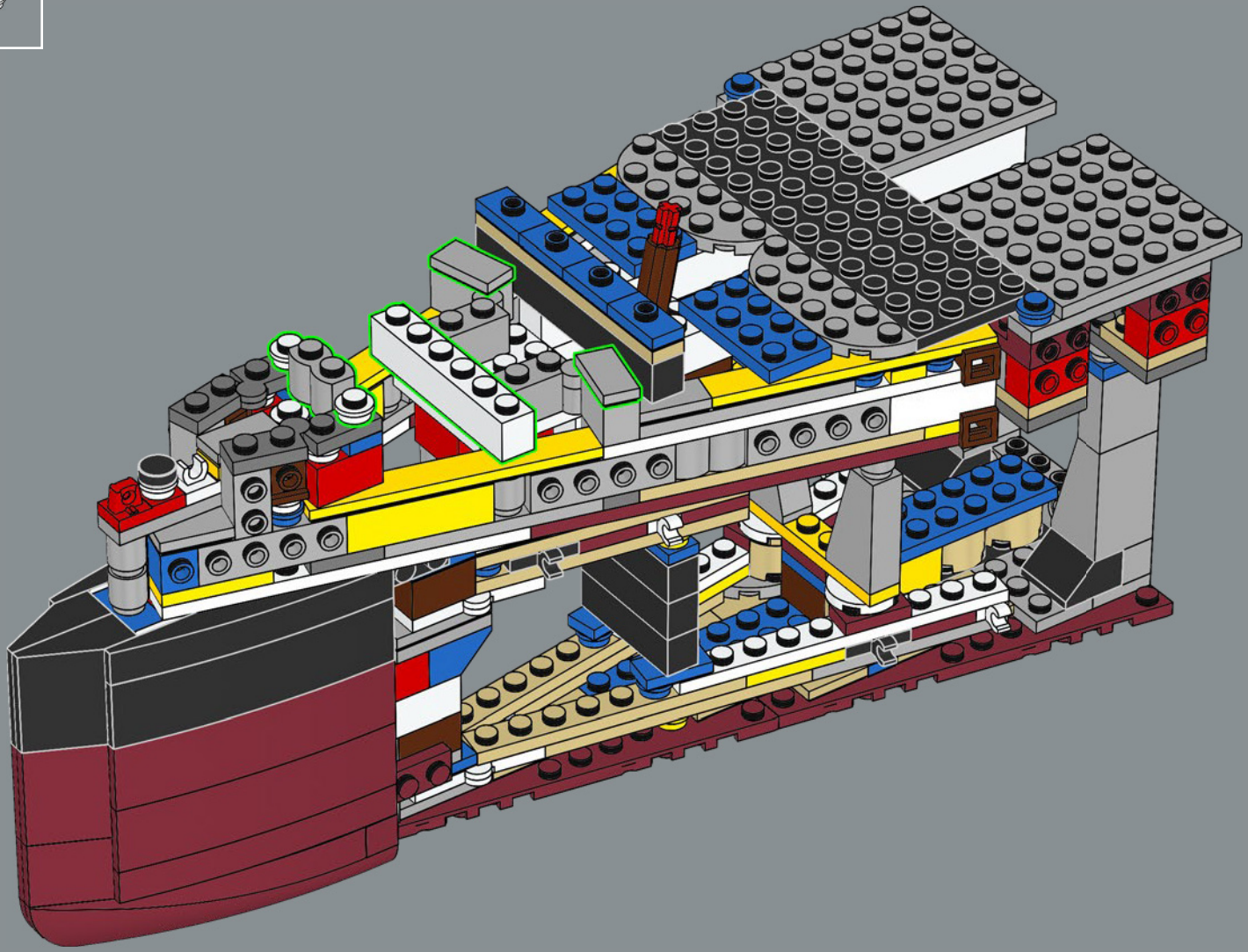

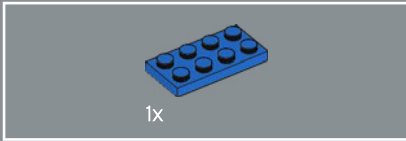
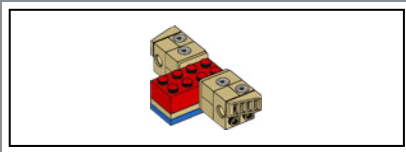

1x

53

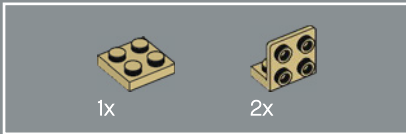
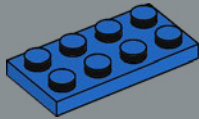

1x

2x

54

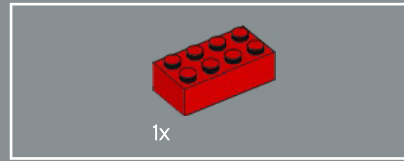
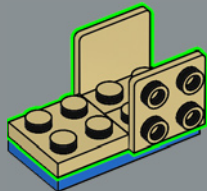

1x

55

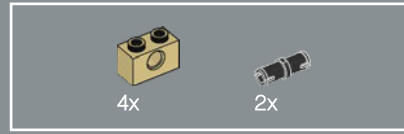
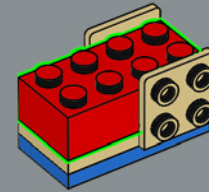

4x

2x

56

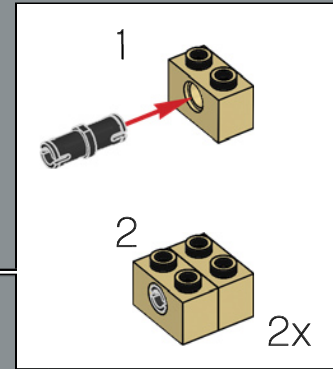

1

2

2x

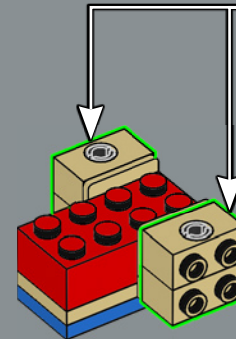

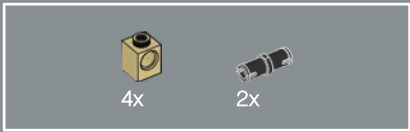

57

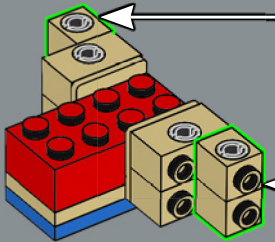
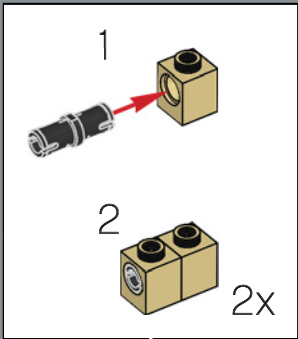

59

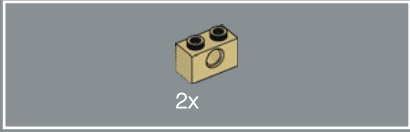
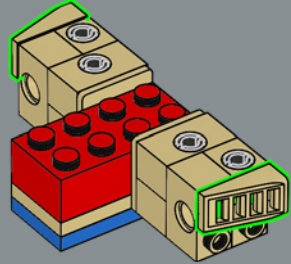

58

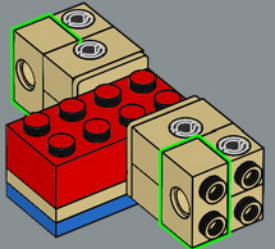

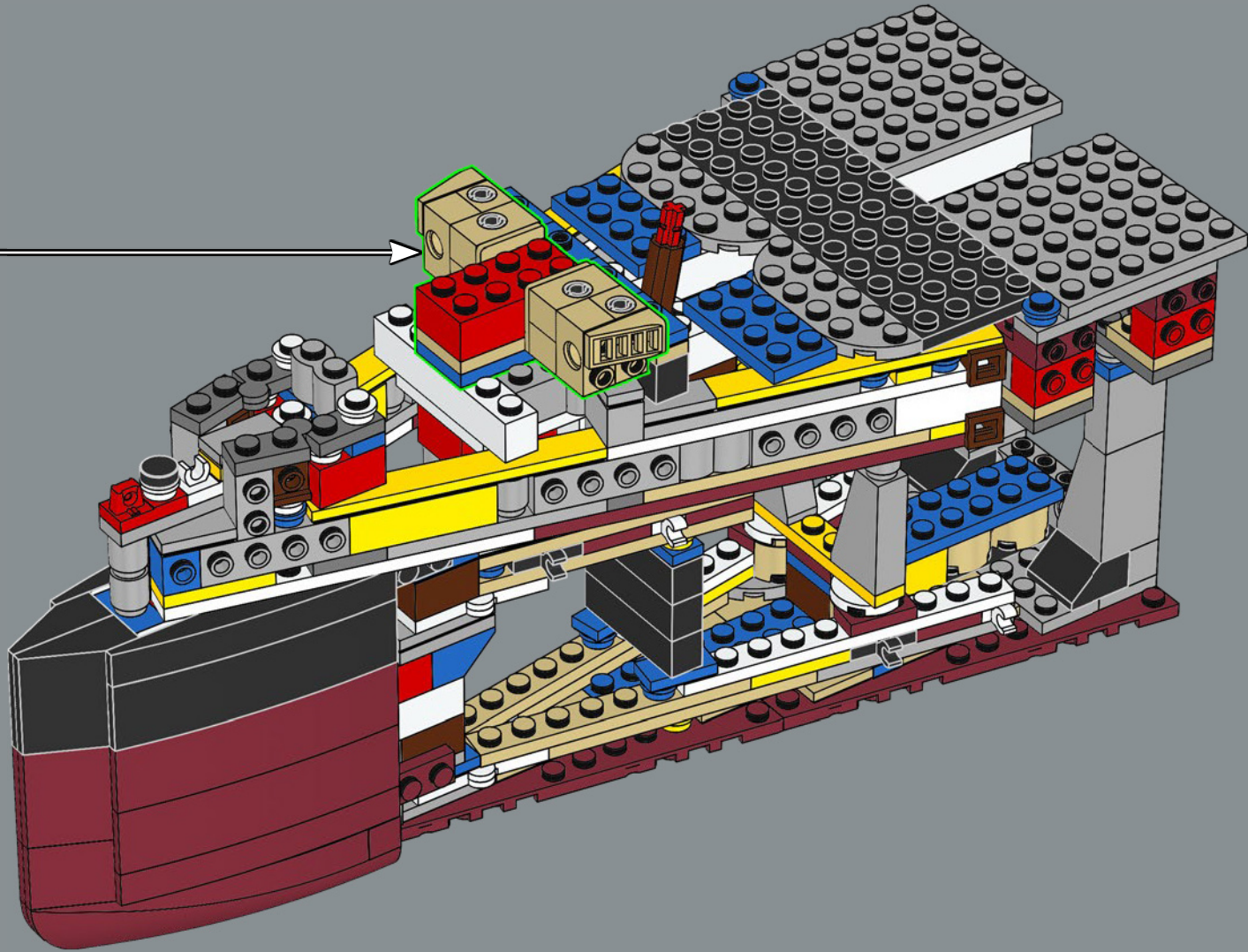

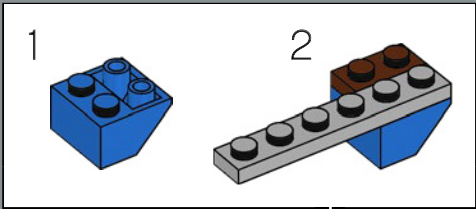
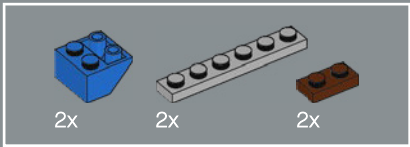



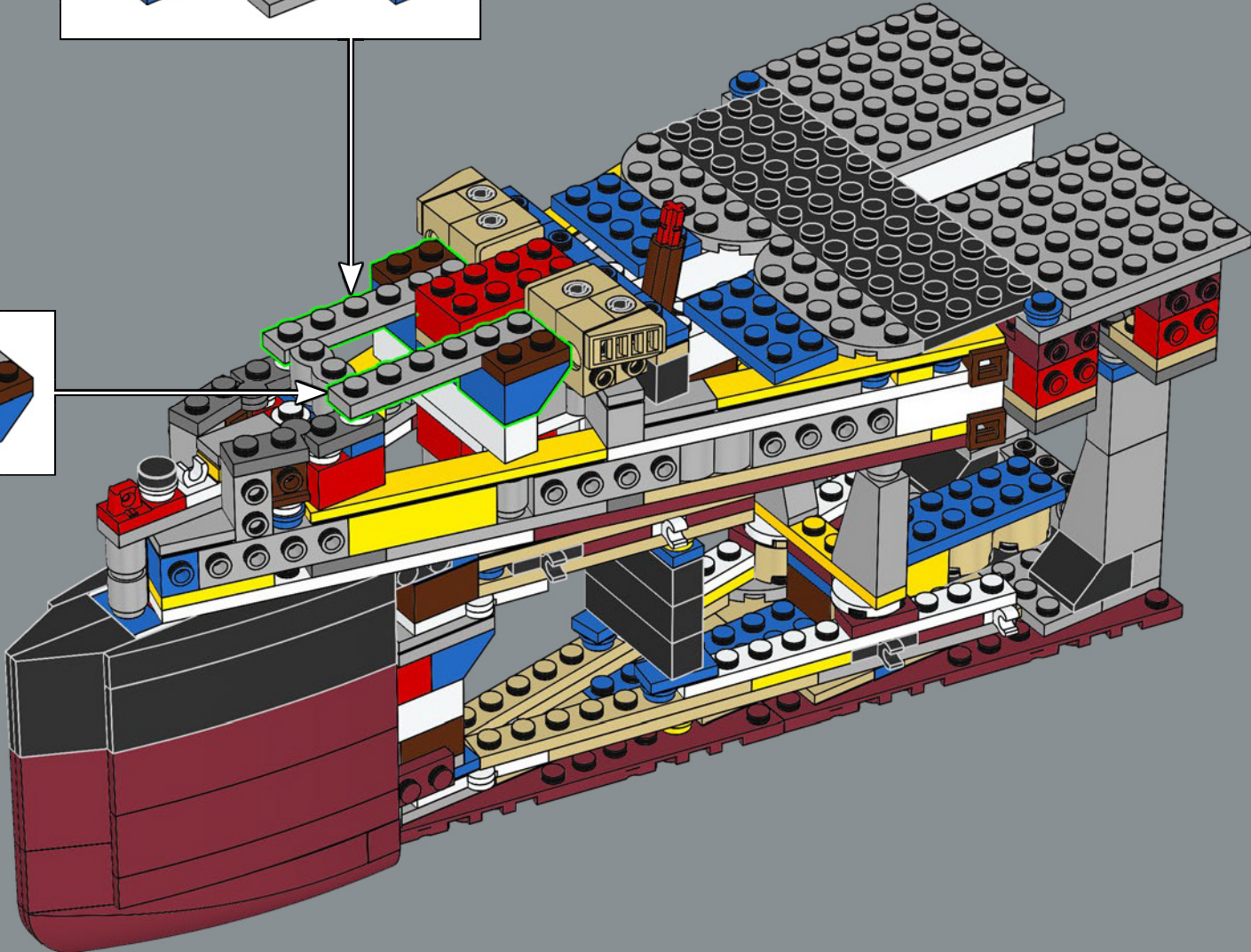
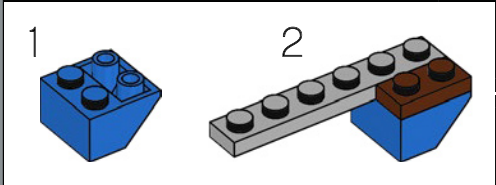



61



-  1x
-  1x
-  1x
-  1x
-  4x
-  1x

62

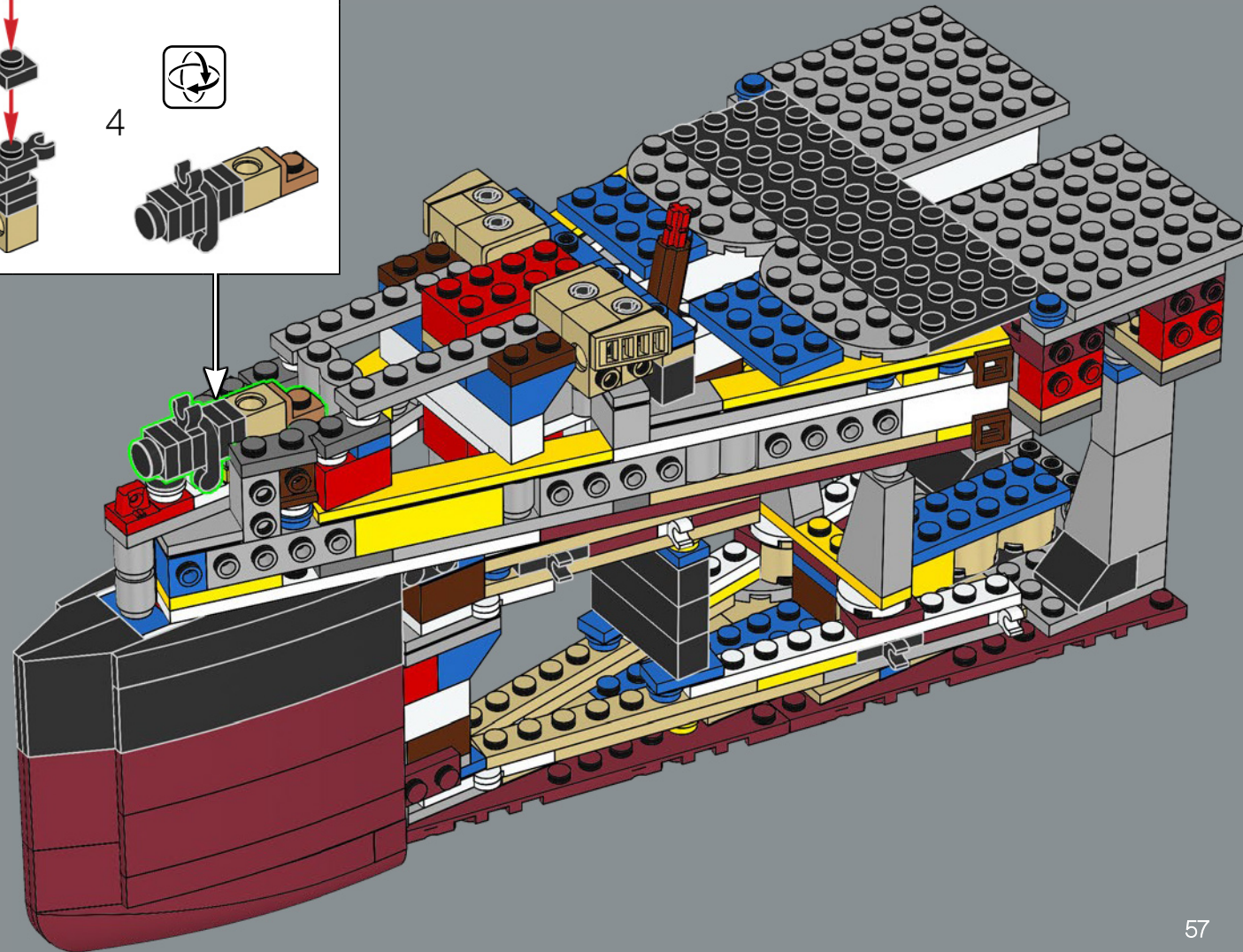
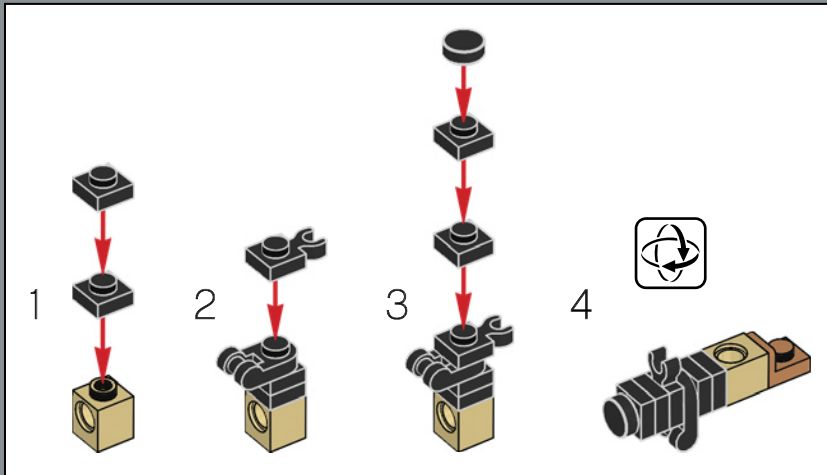

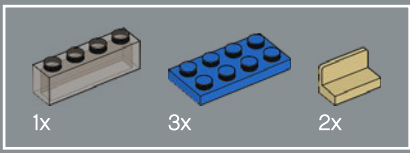

63

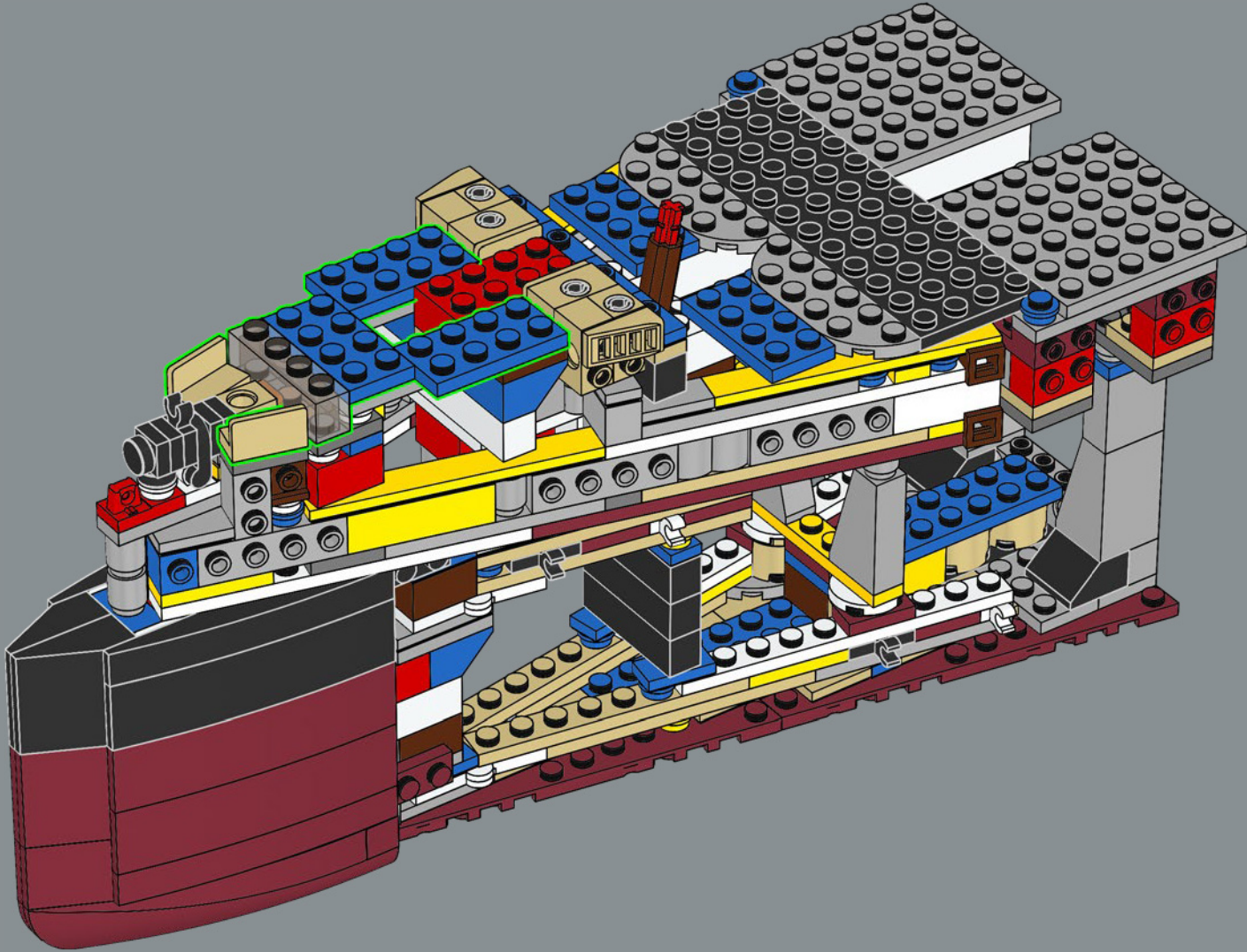

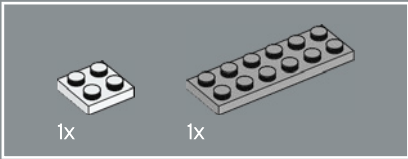
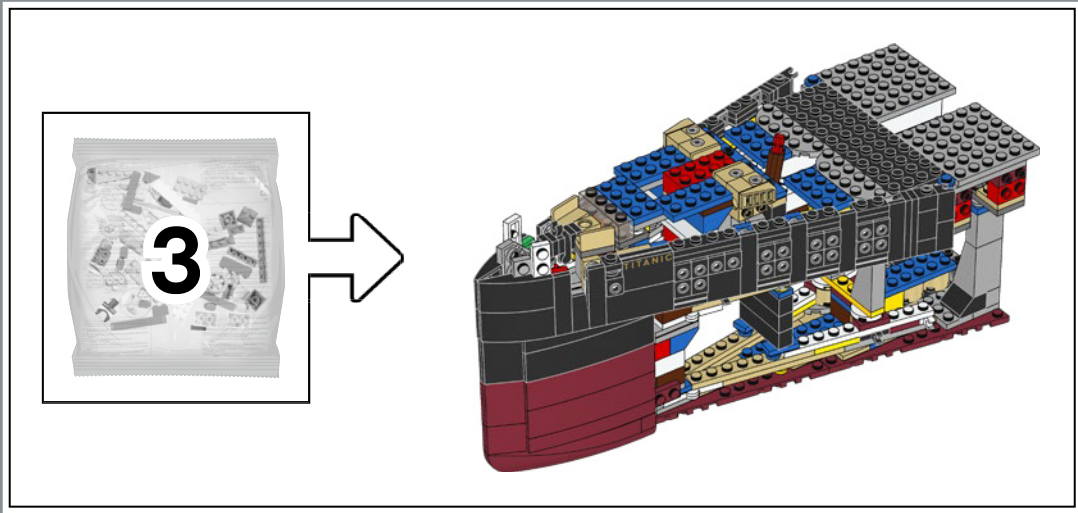

65

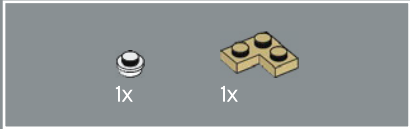
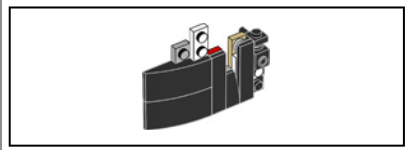

64

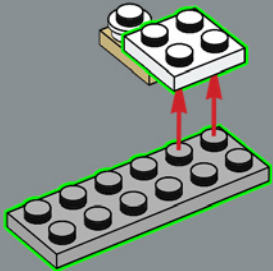
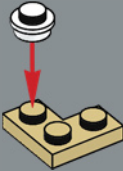

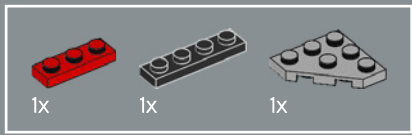

66

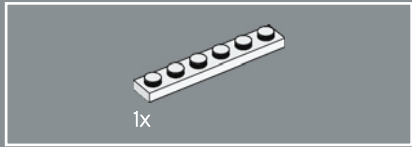
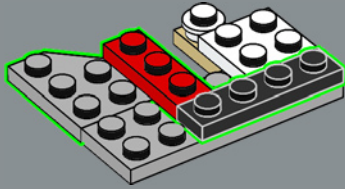

67

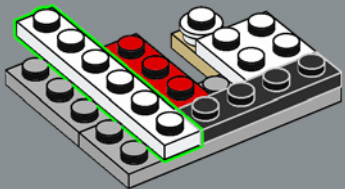

68

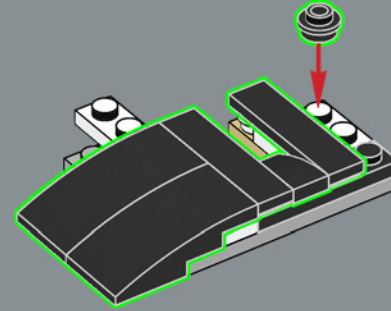

69

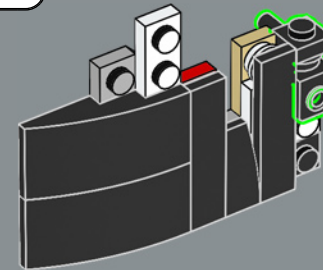
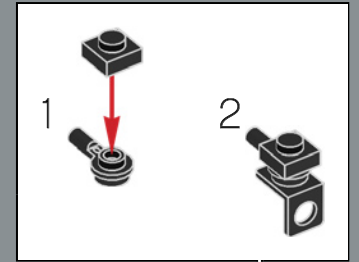

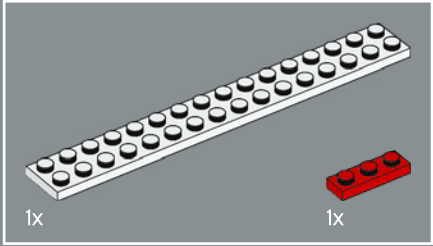
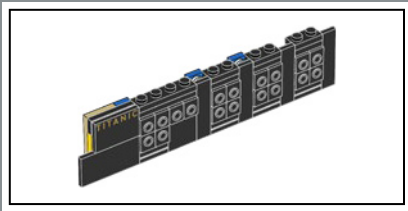

71

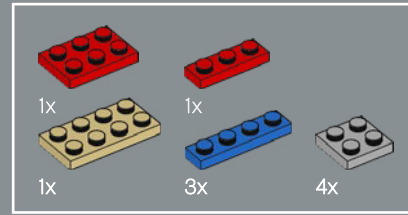
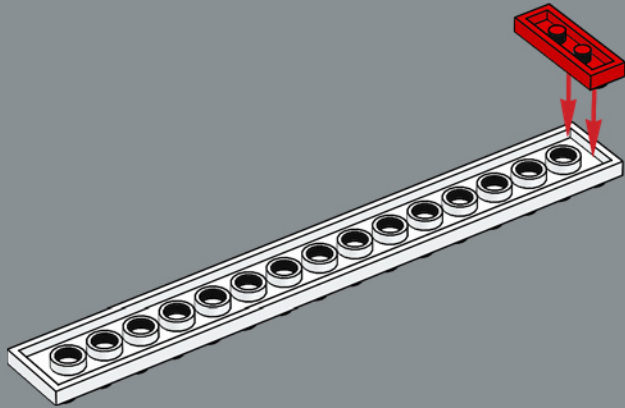

72

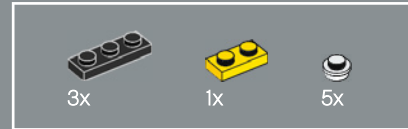
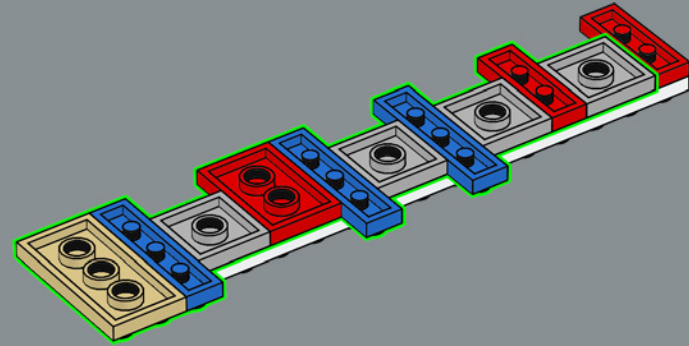

73

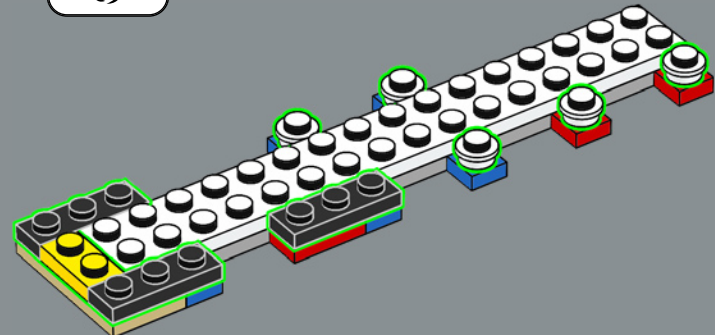

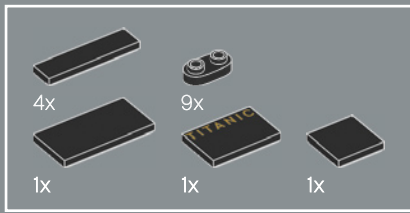

74

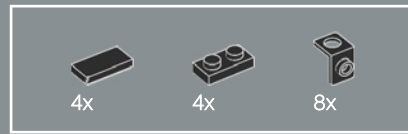
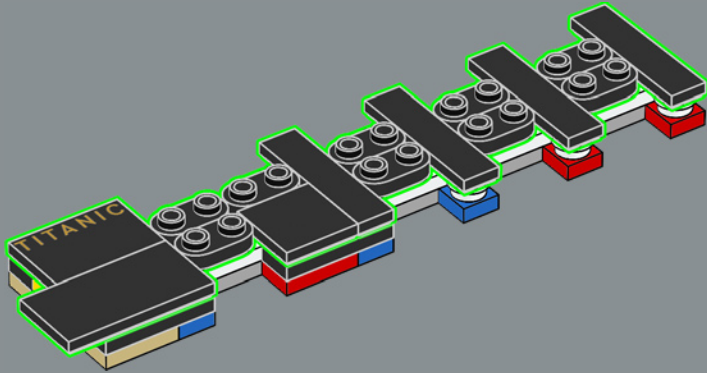

75

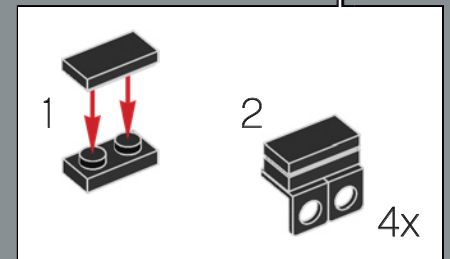
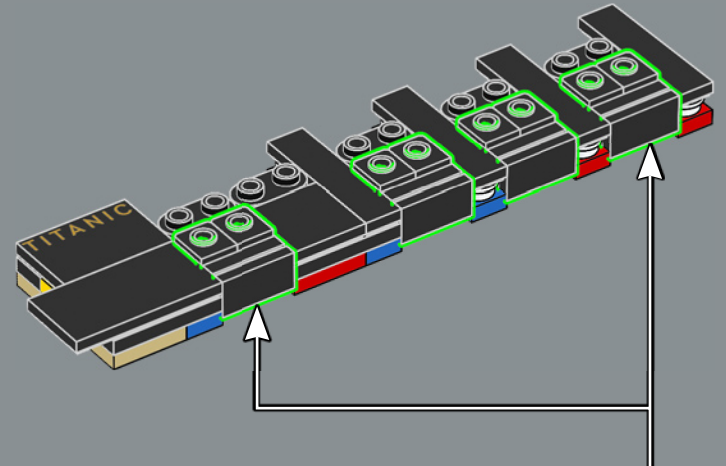

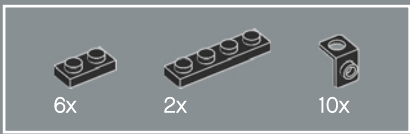

76

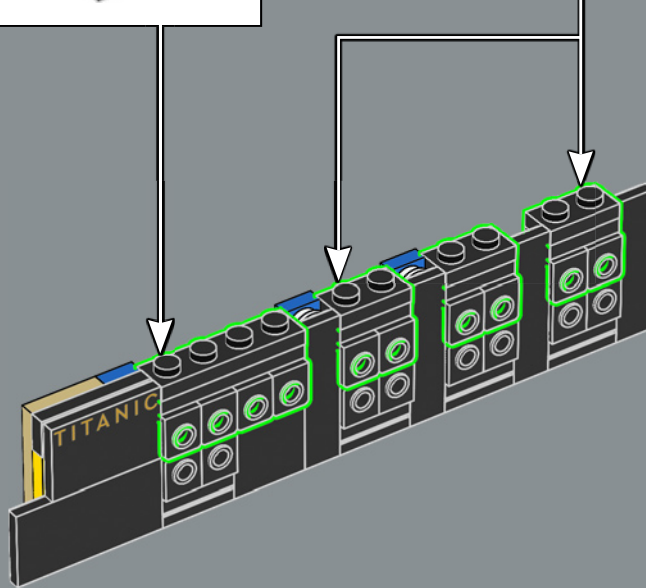
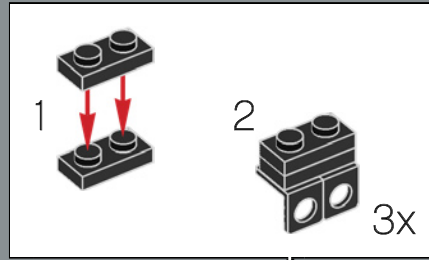
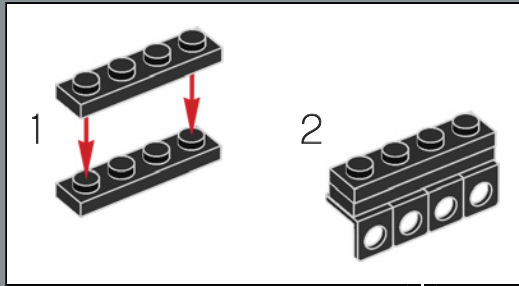

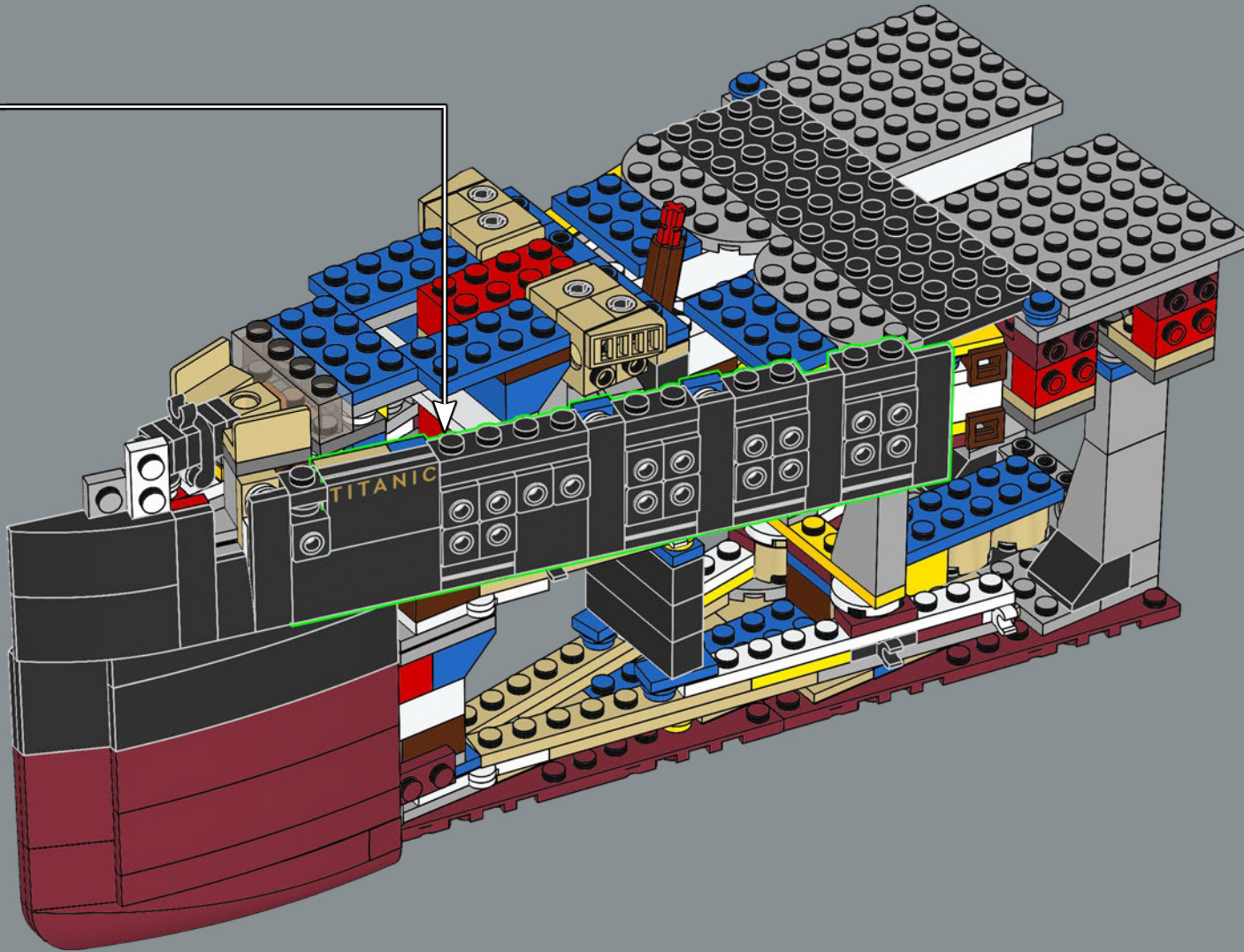

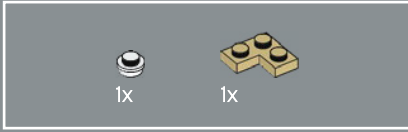
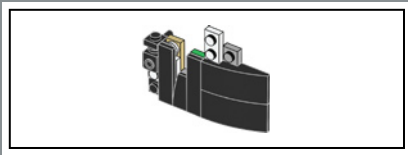

78

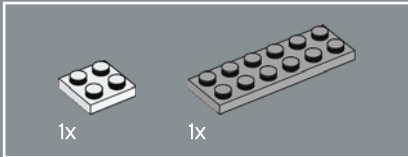
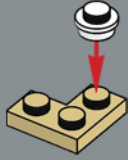

79

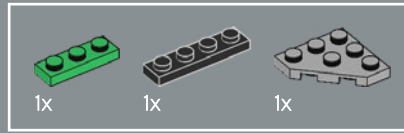
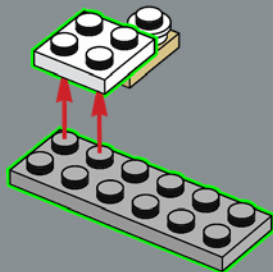

80

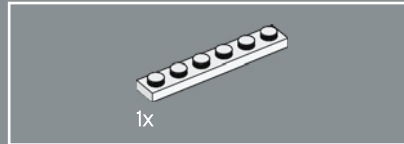
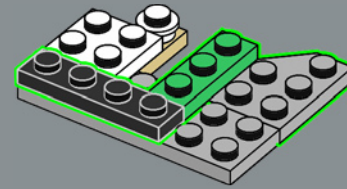

81

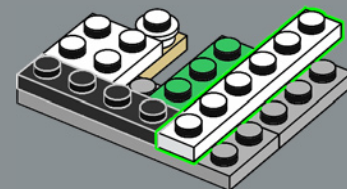



82

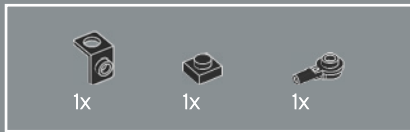
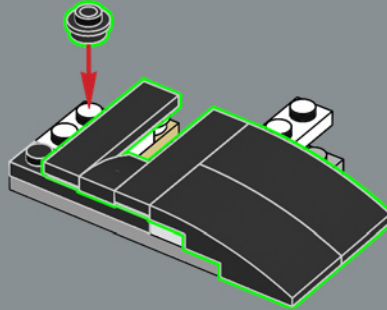

83

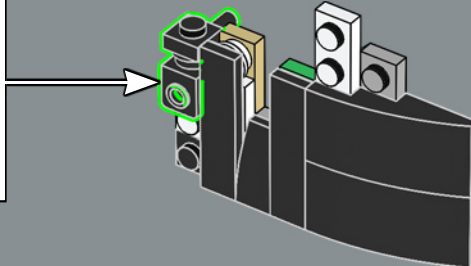
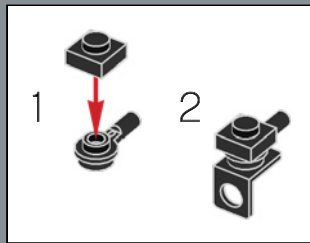

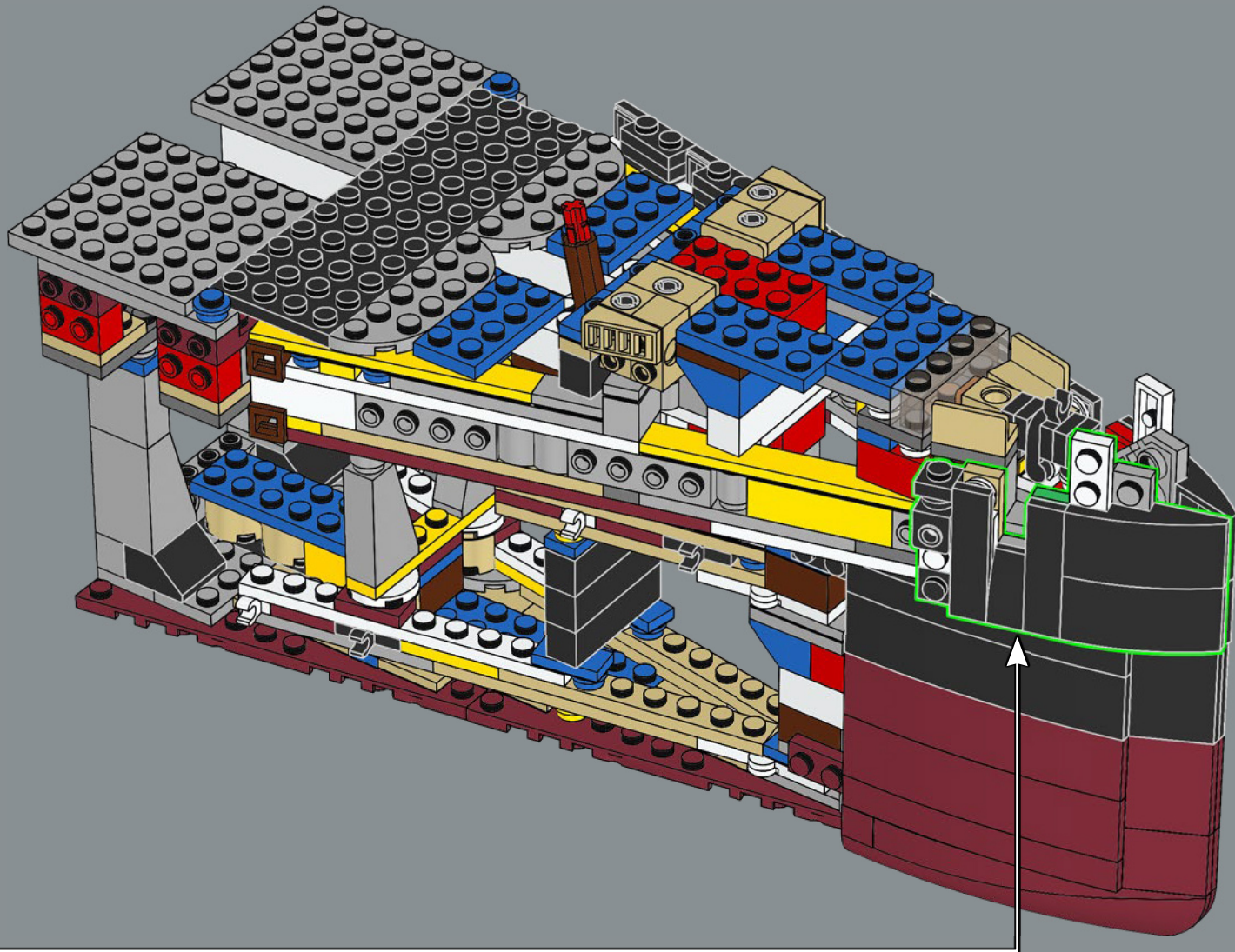

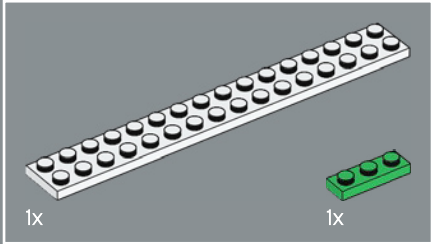
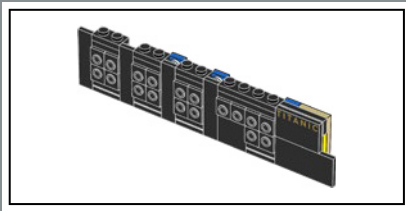

85

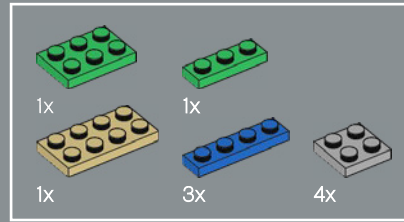
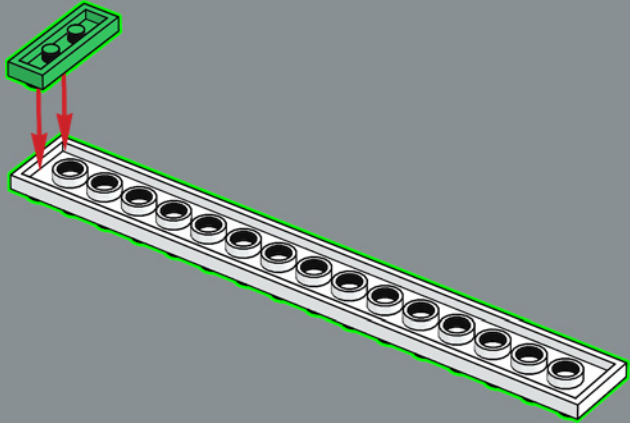

86

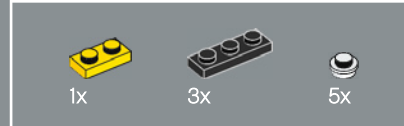
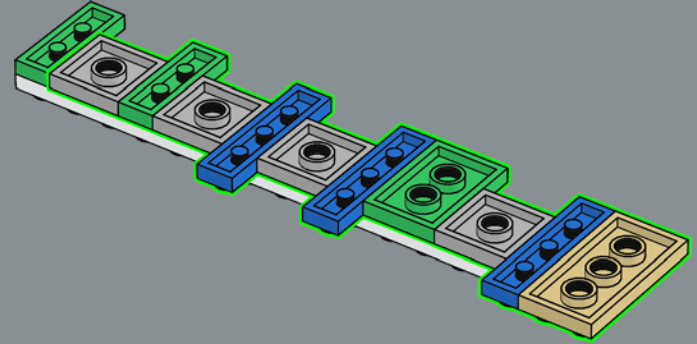

87

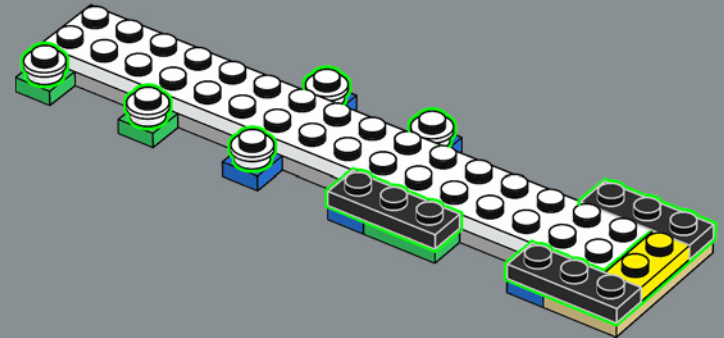

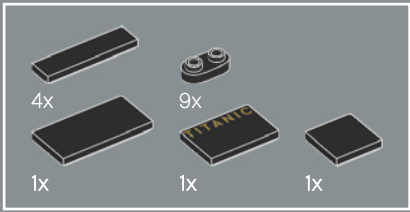

88

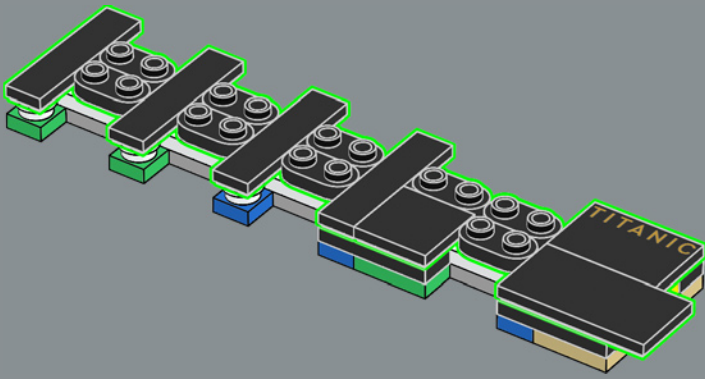

89

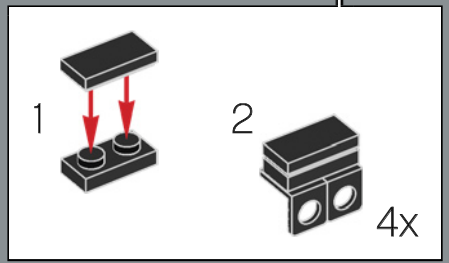
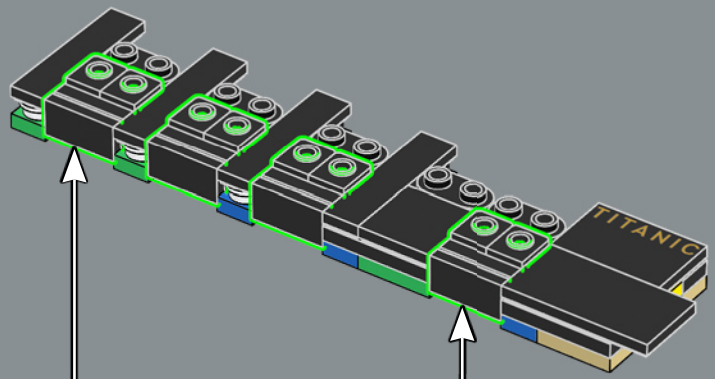

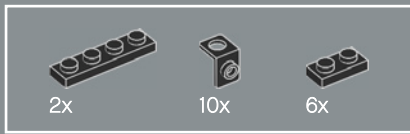

90

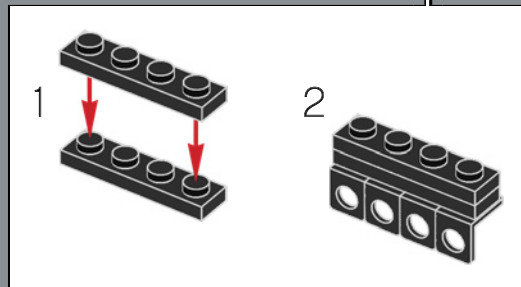
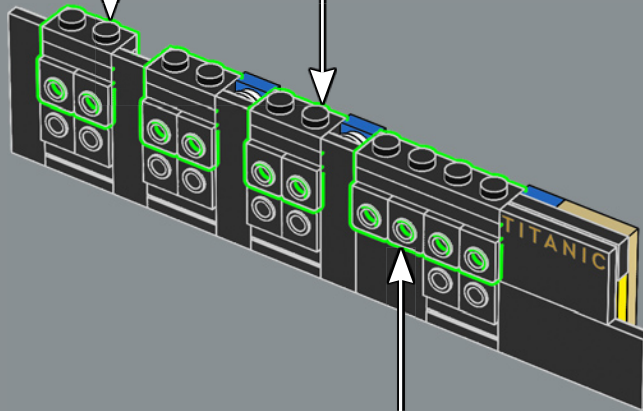
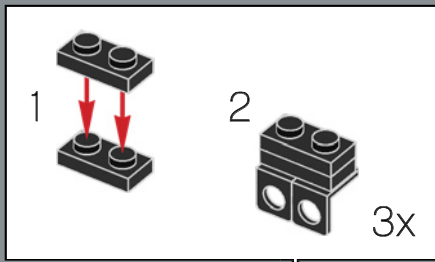

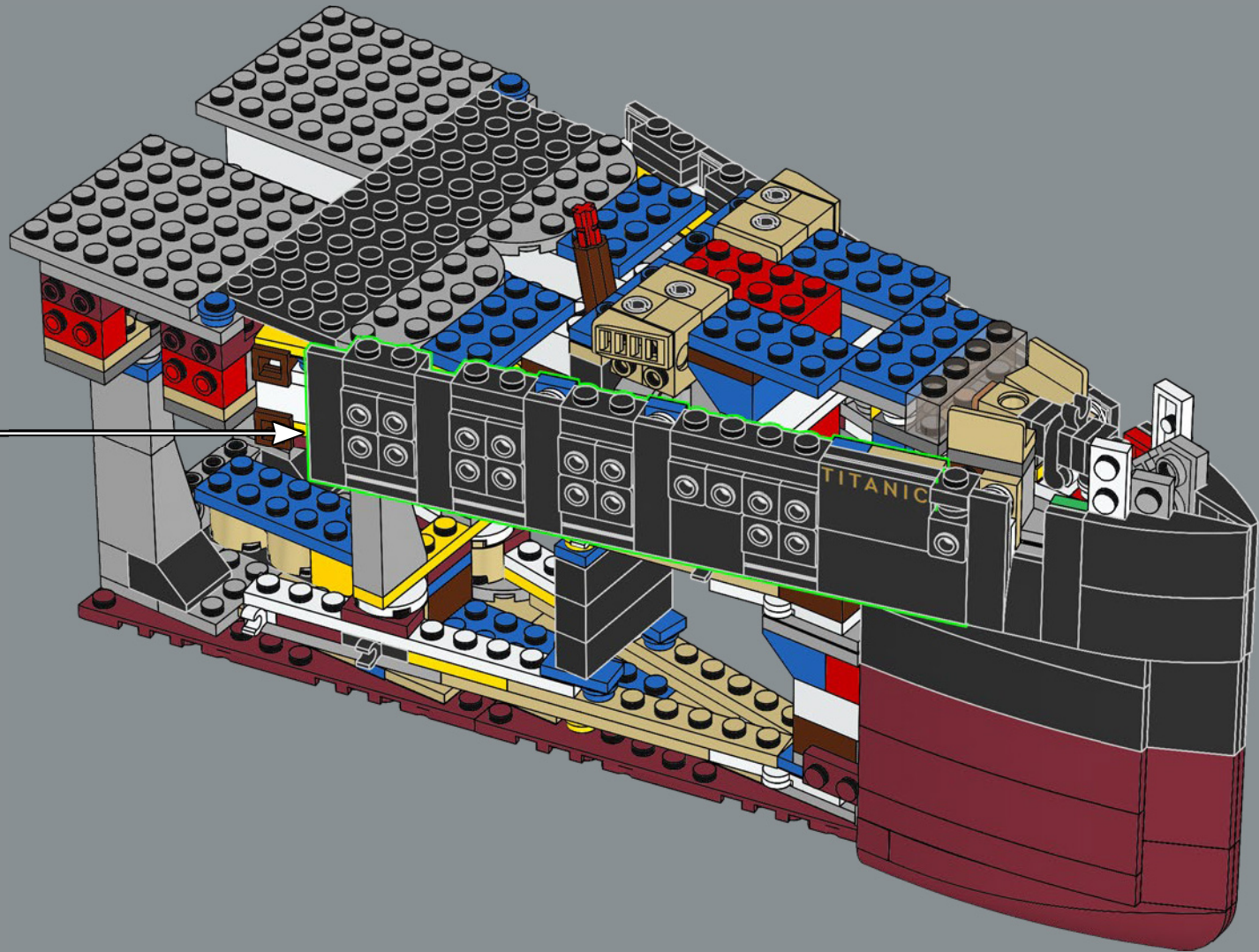

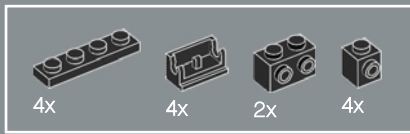

92

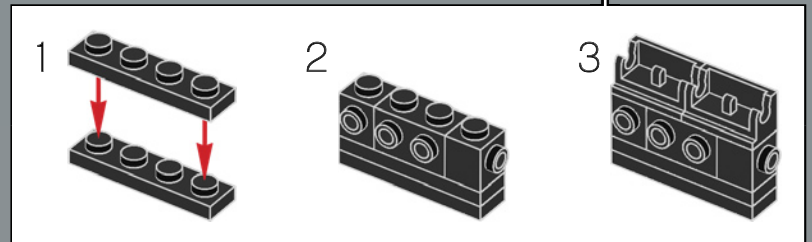
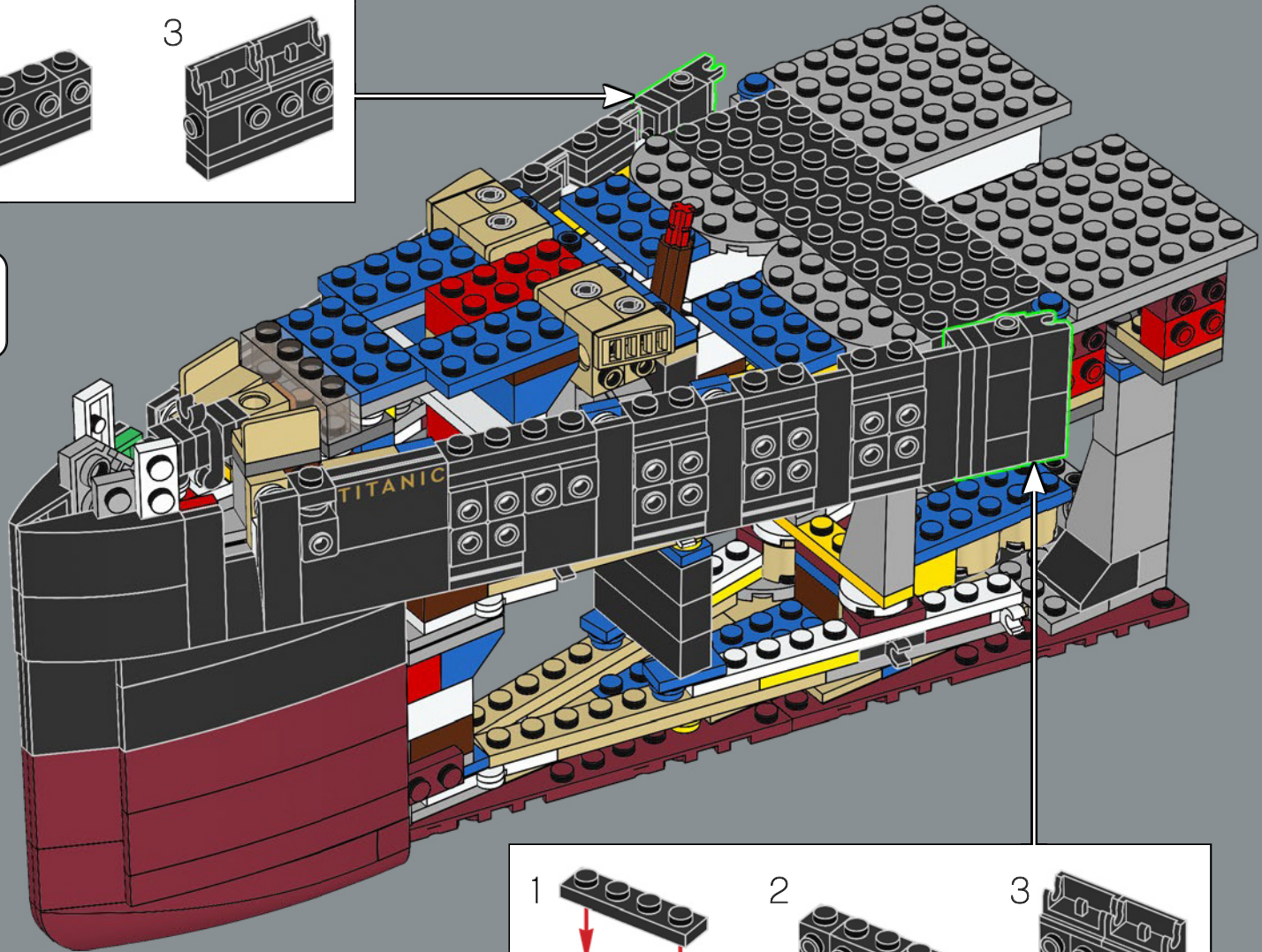
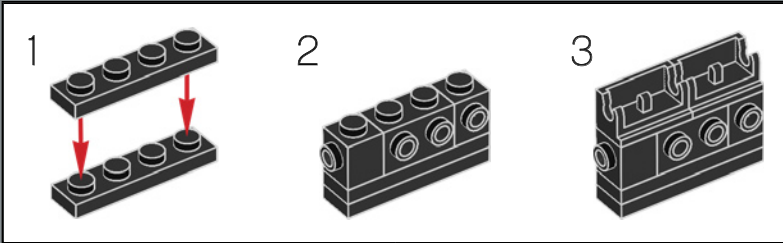

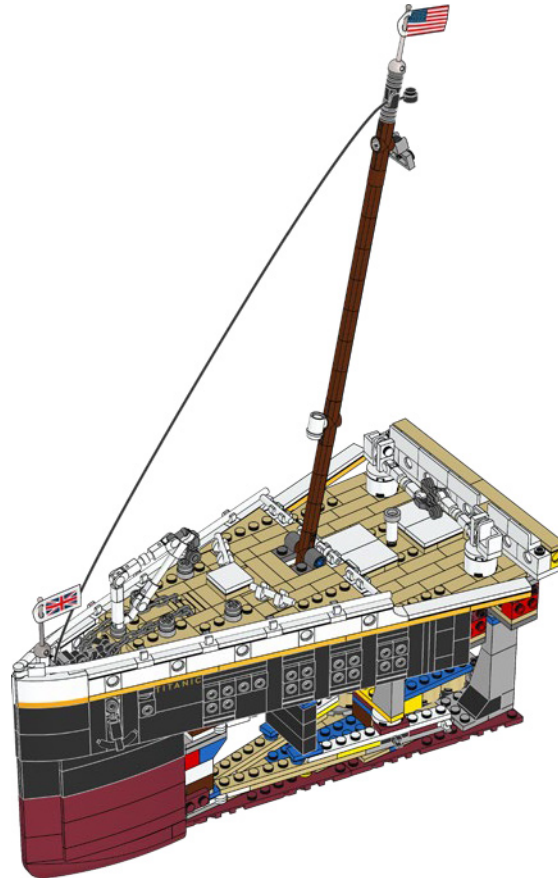

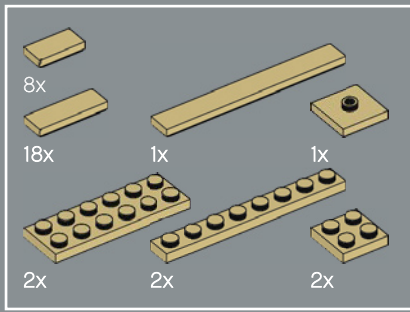

93

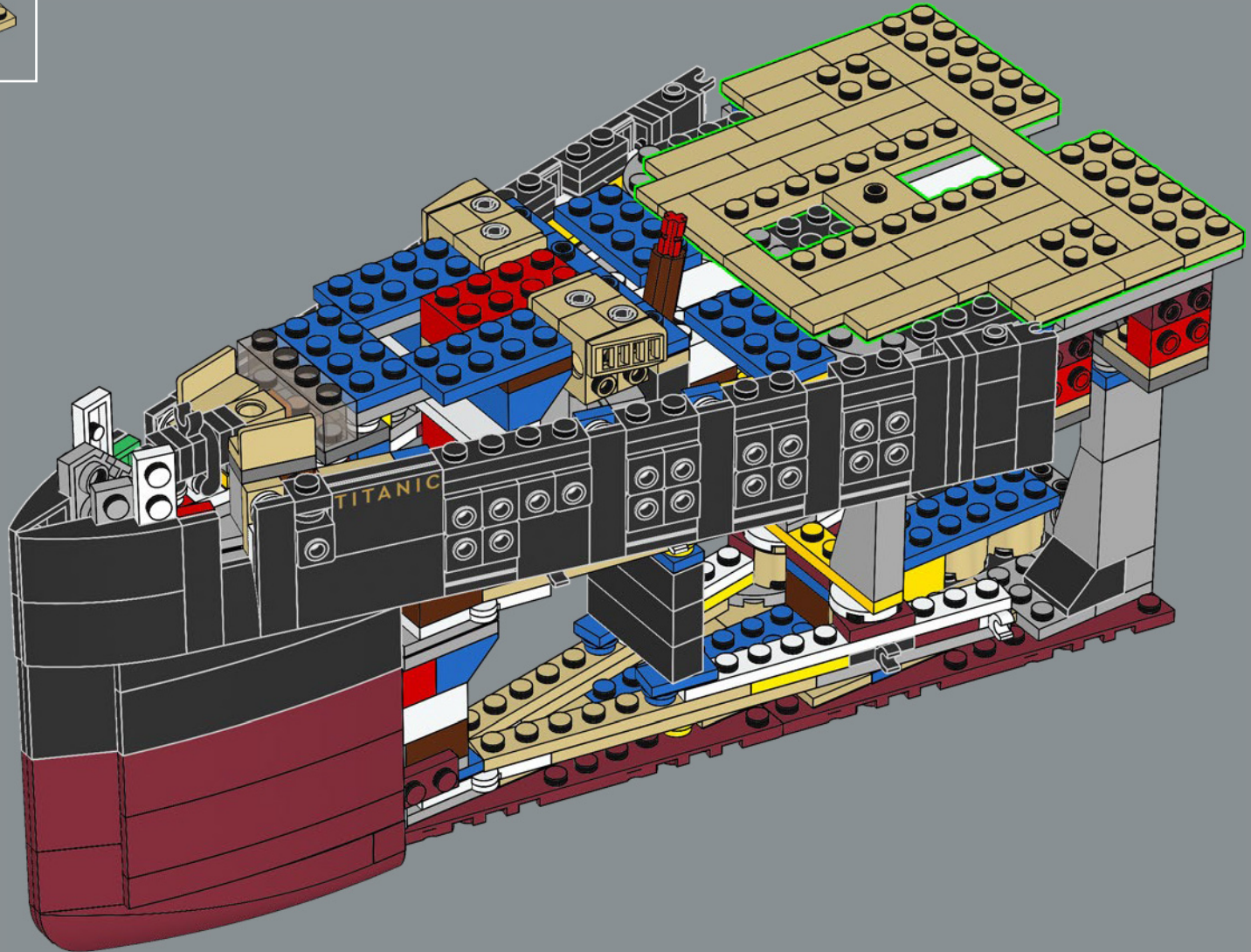

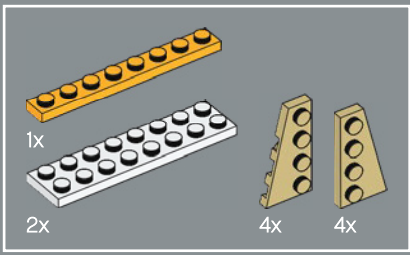

94

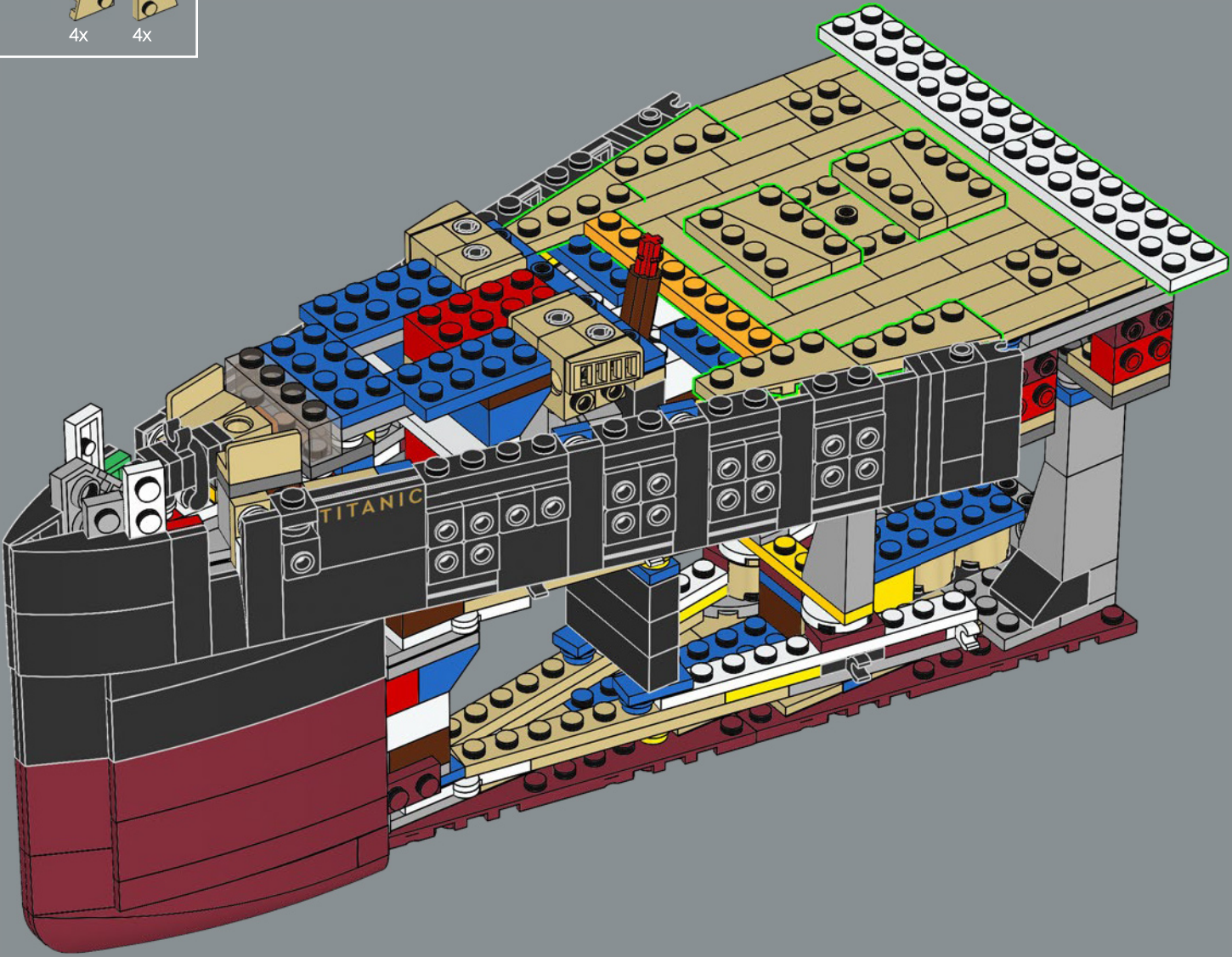

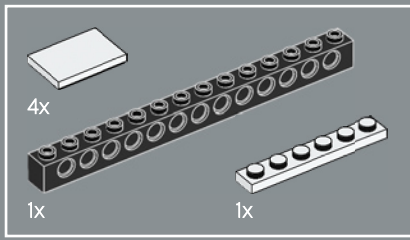

95

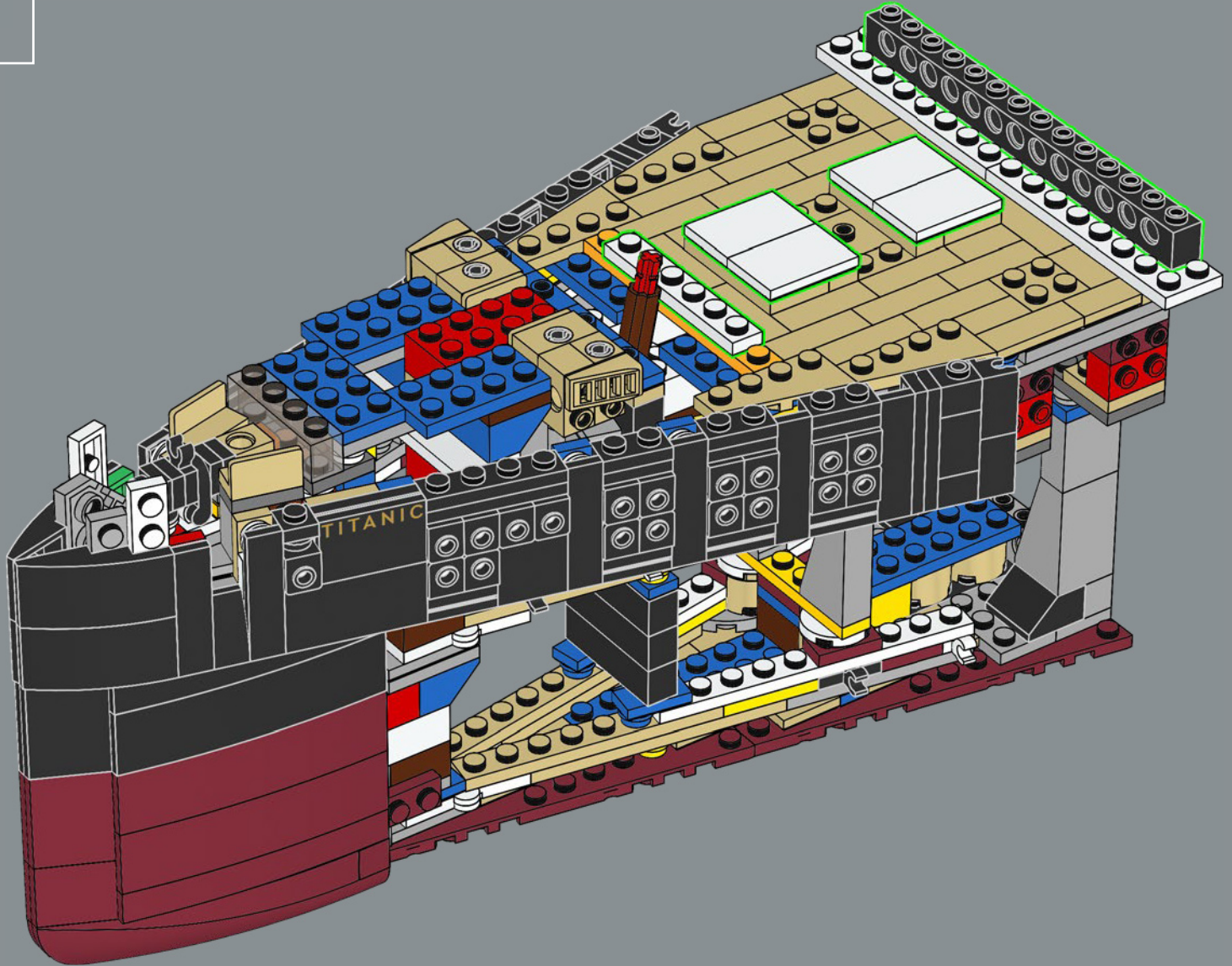

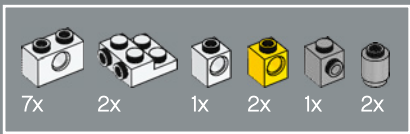

96

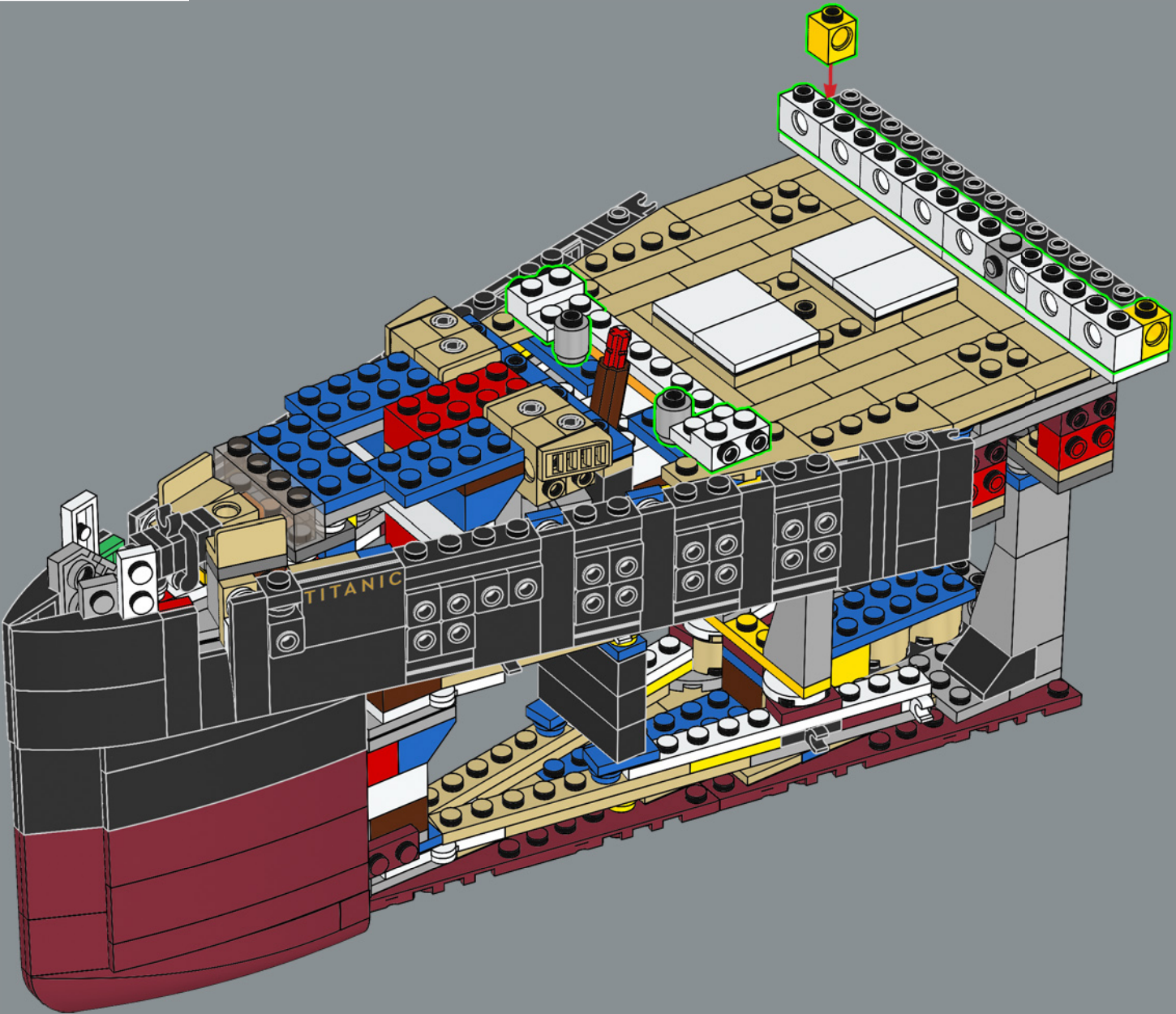

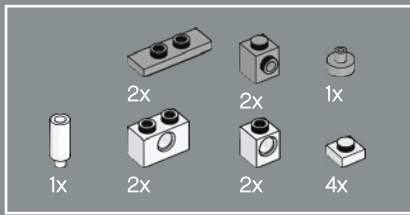

97

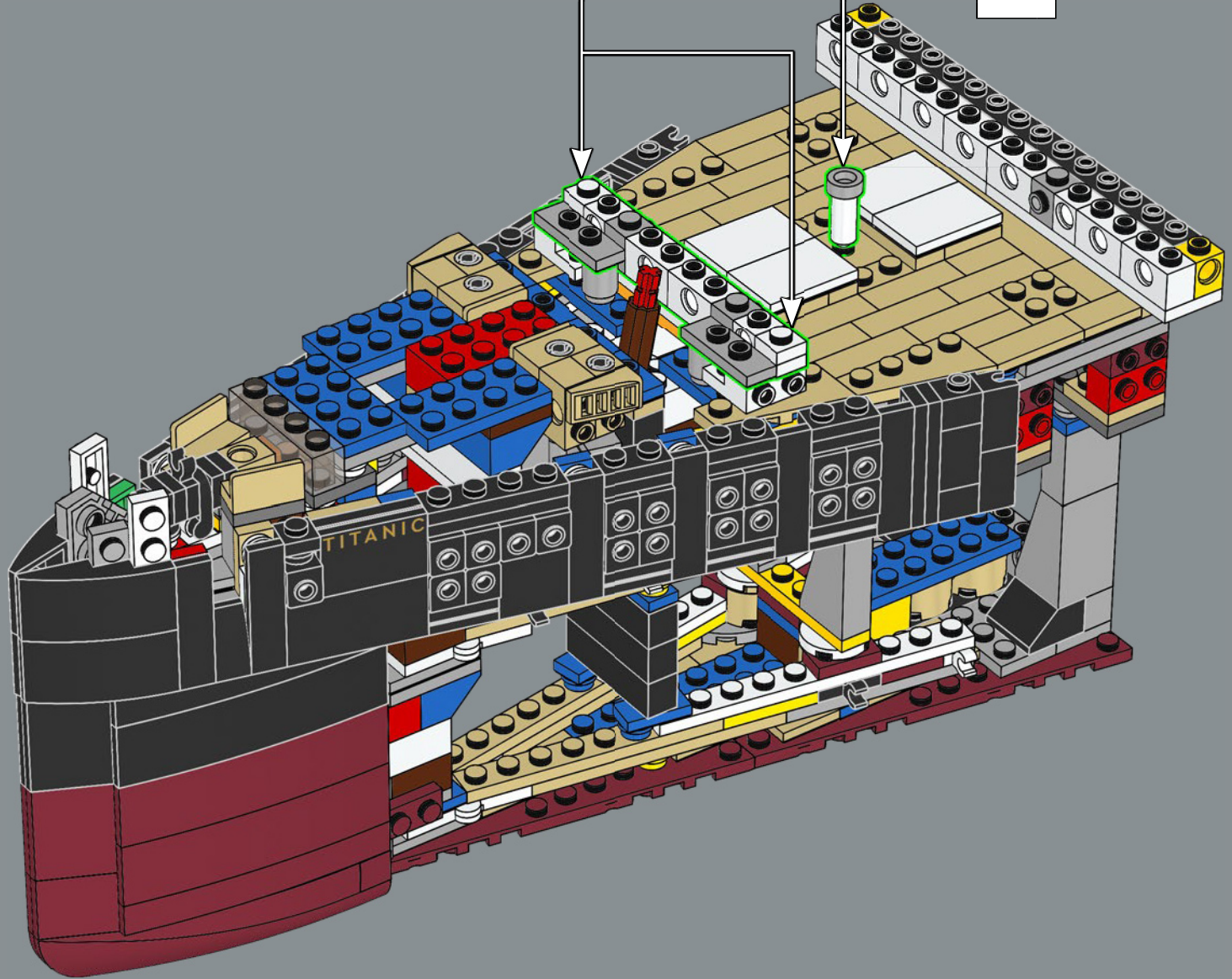
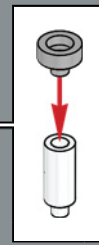
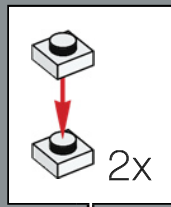

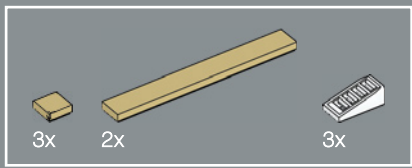

98

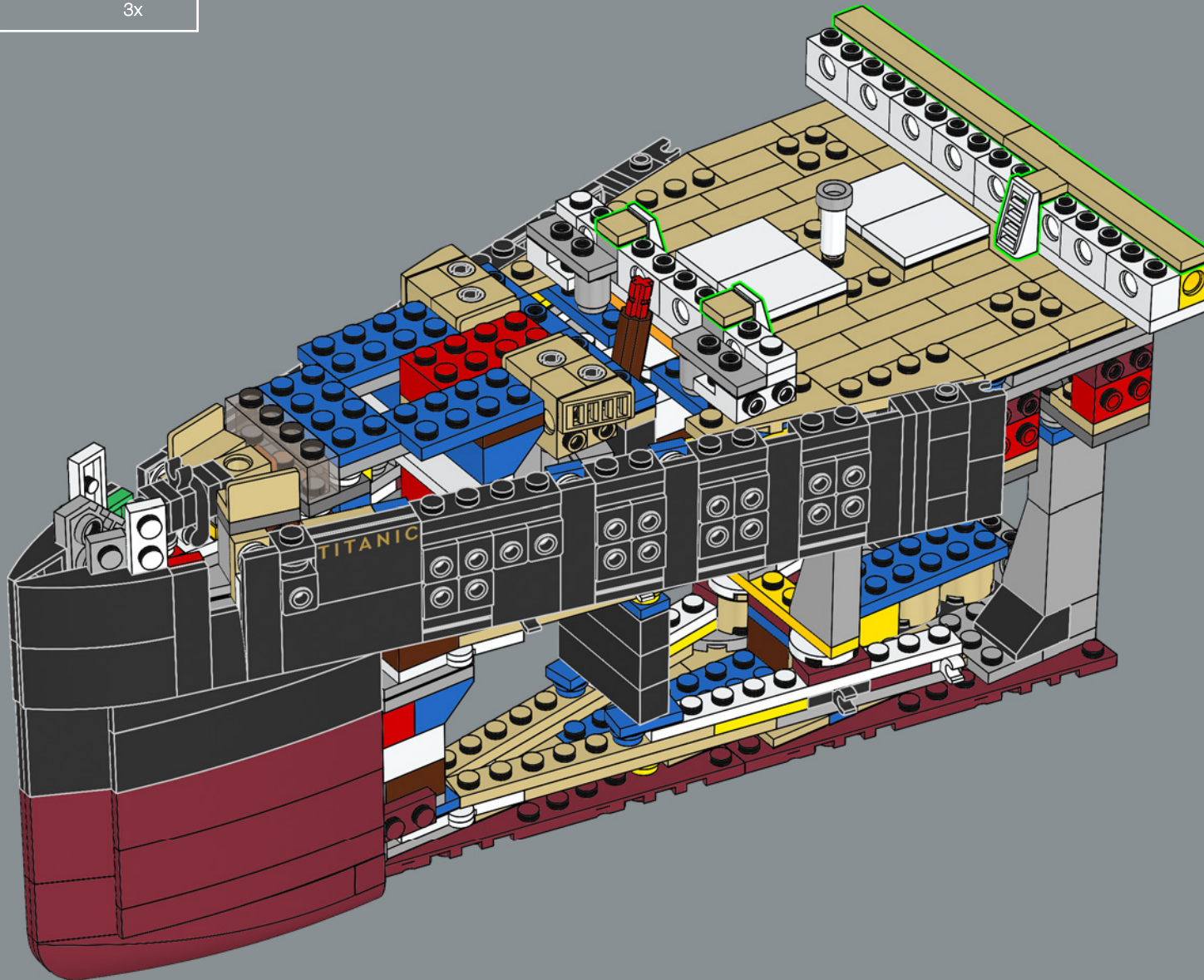

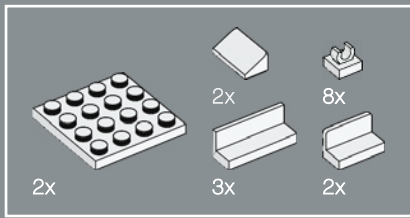

99

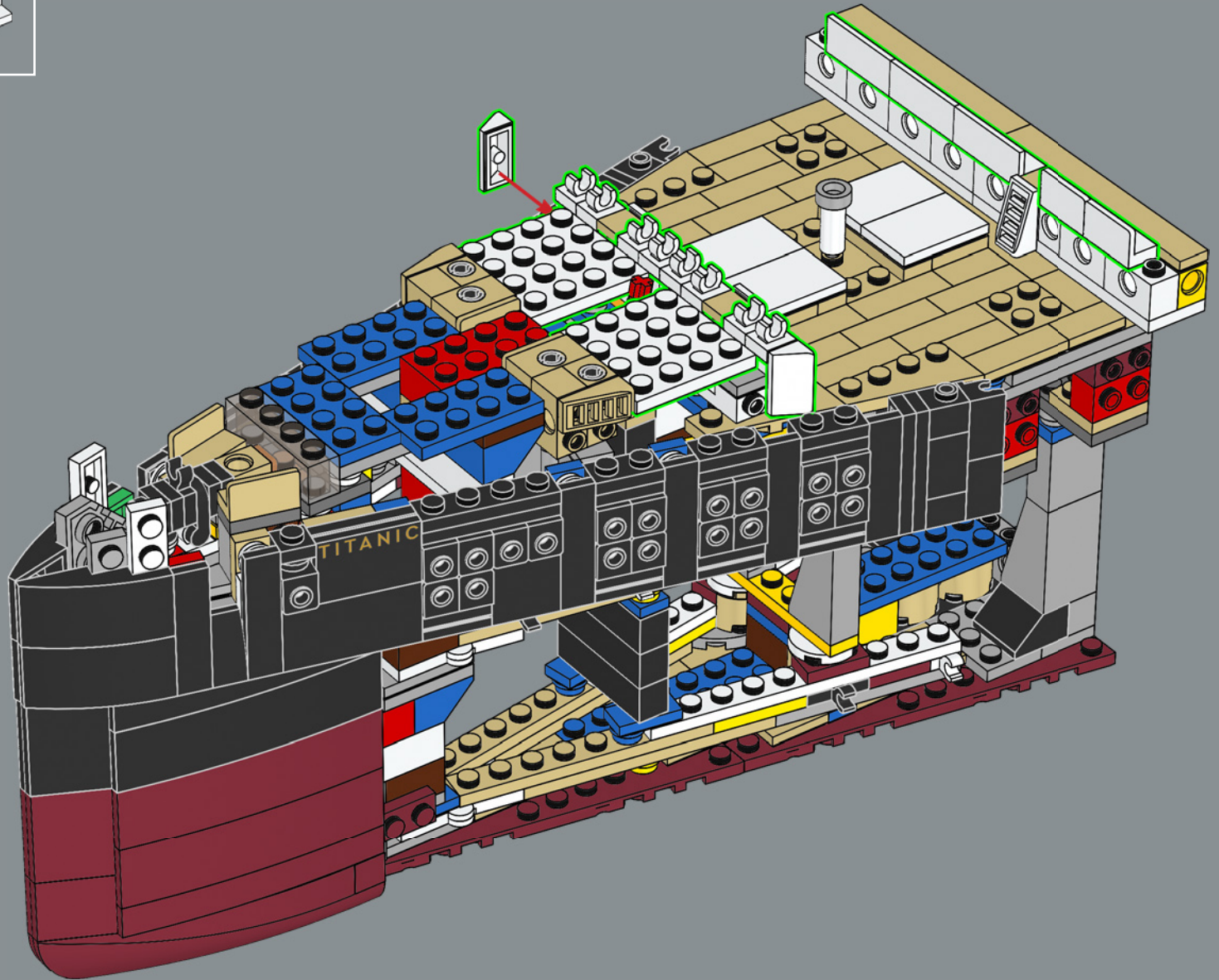

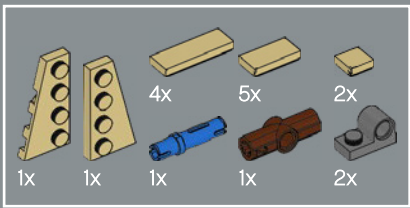

100

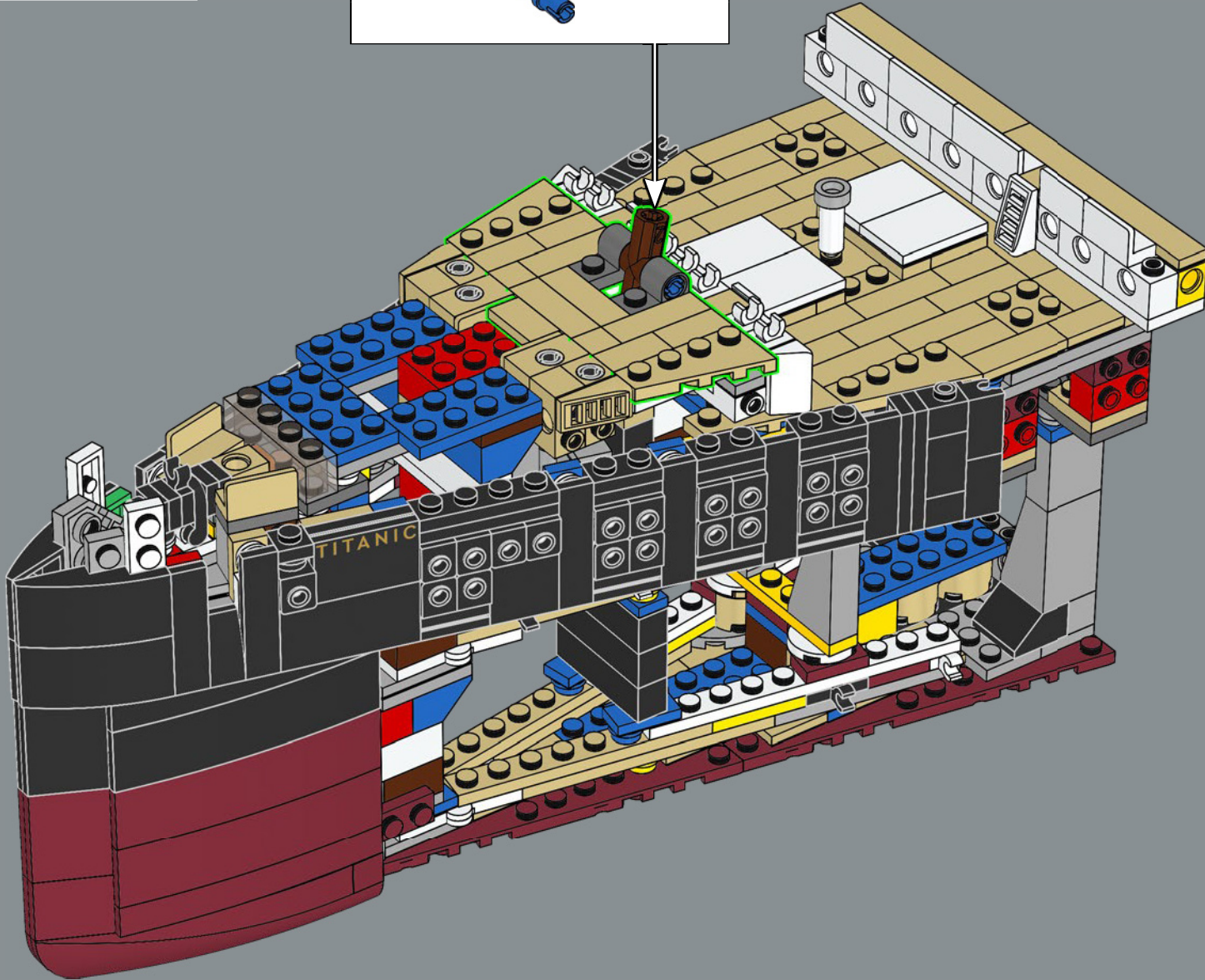
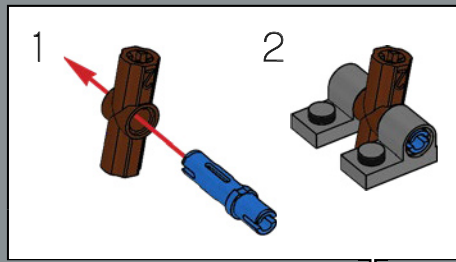

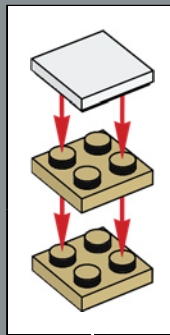
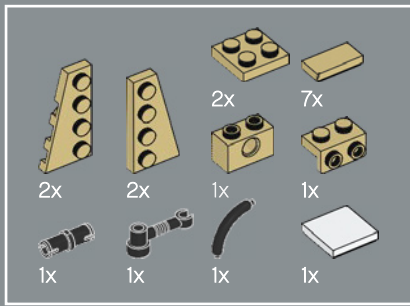

101

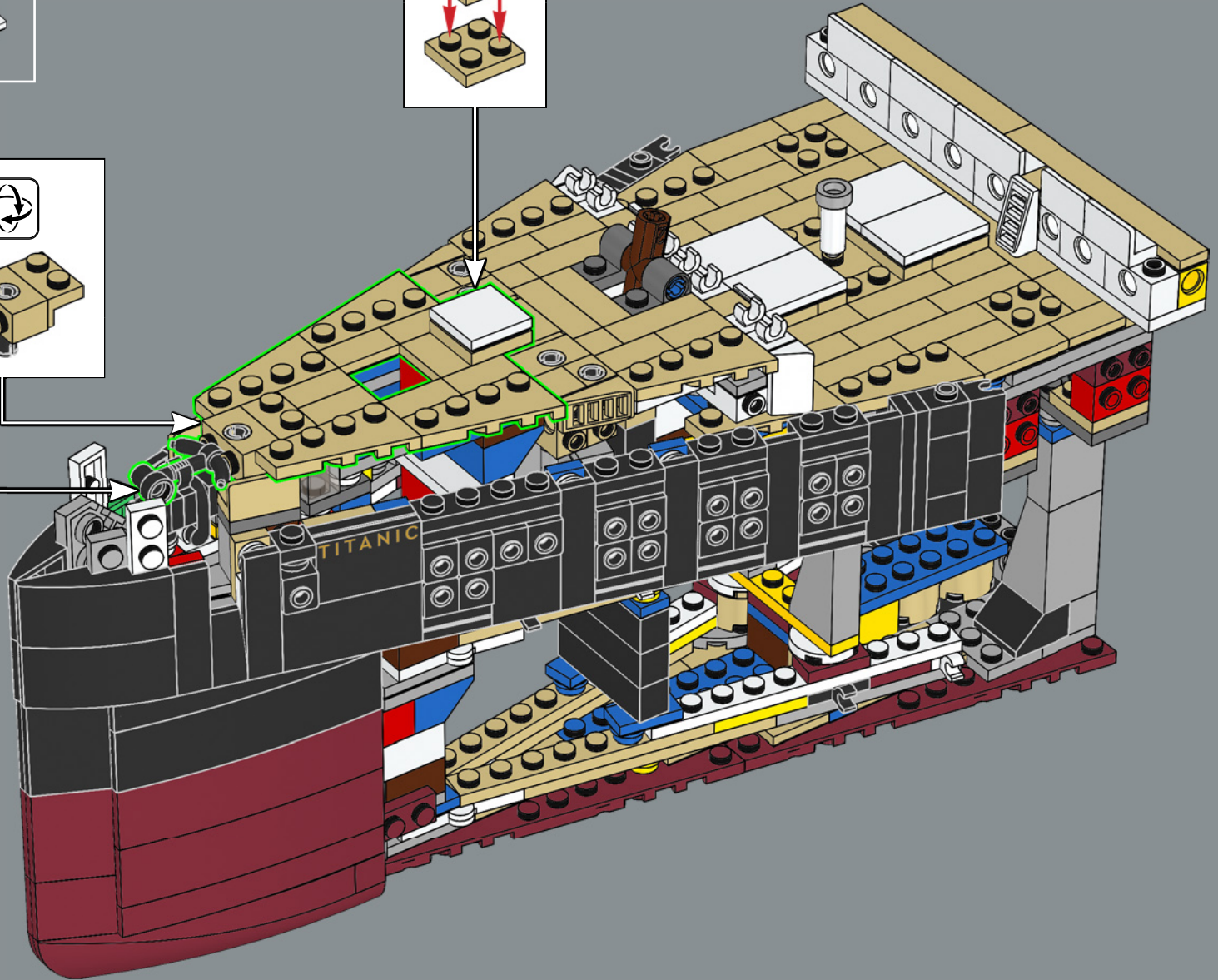
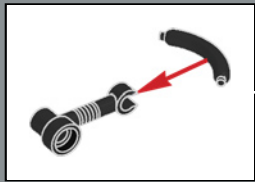
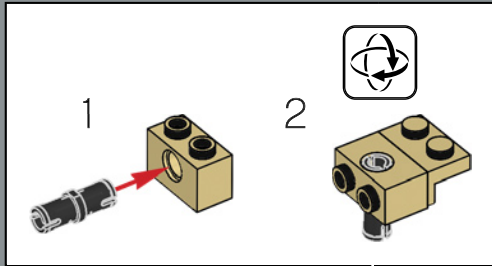

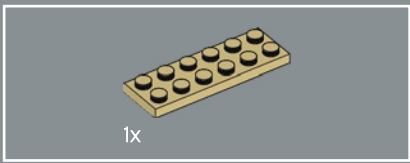

102

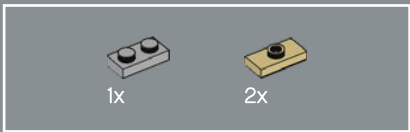
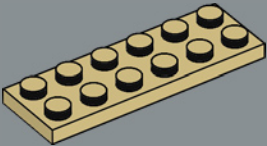

103

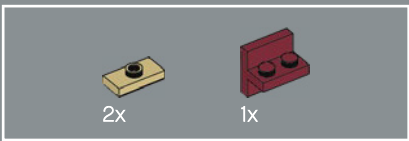
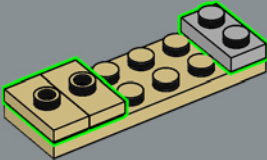

104

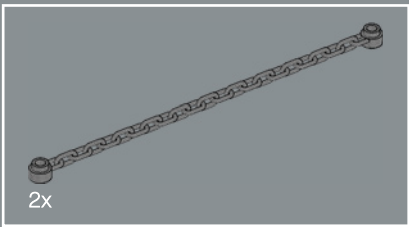
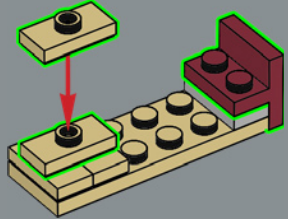

105

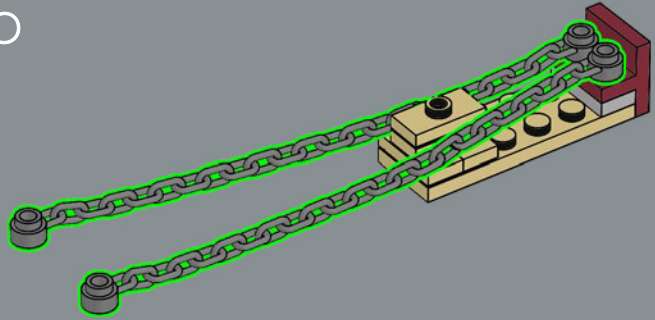

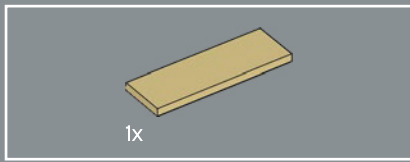

106

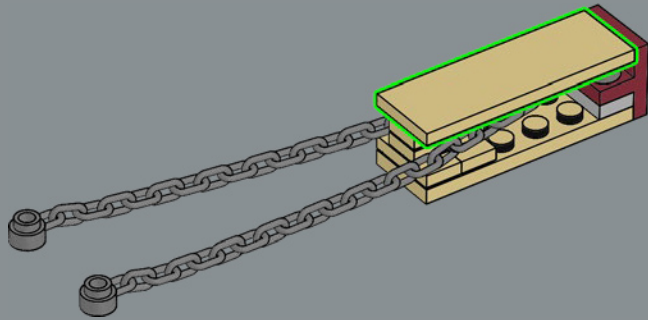

107

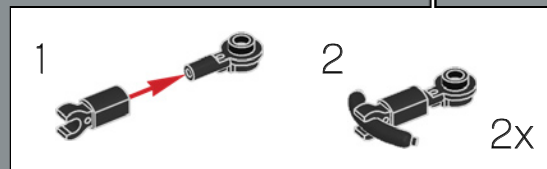
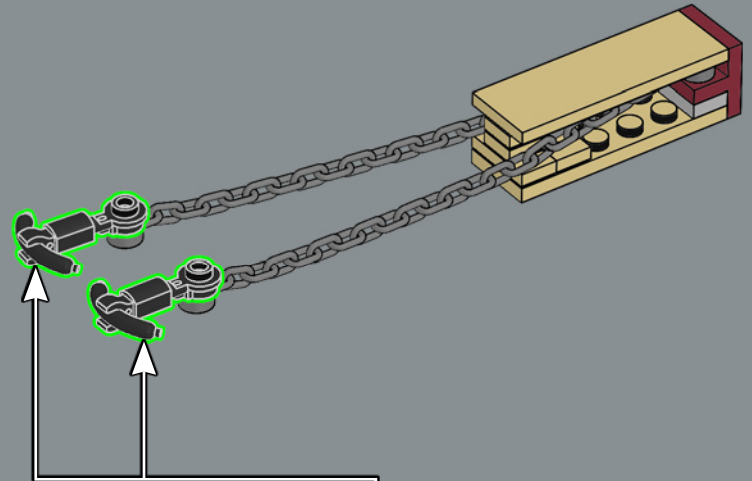

Il *Titanic* era dotato di tre ancore:
una per ciascun lato e la più pesante al centro.

108

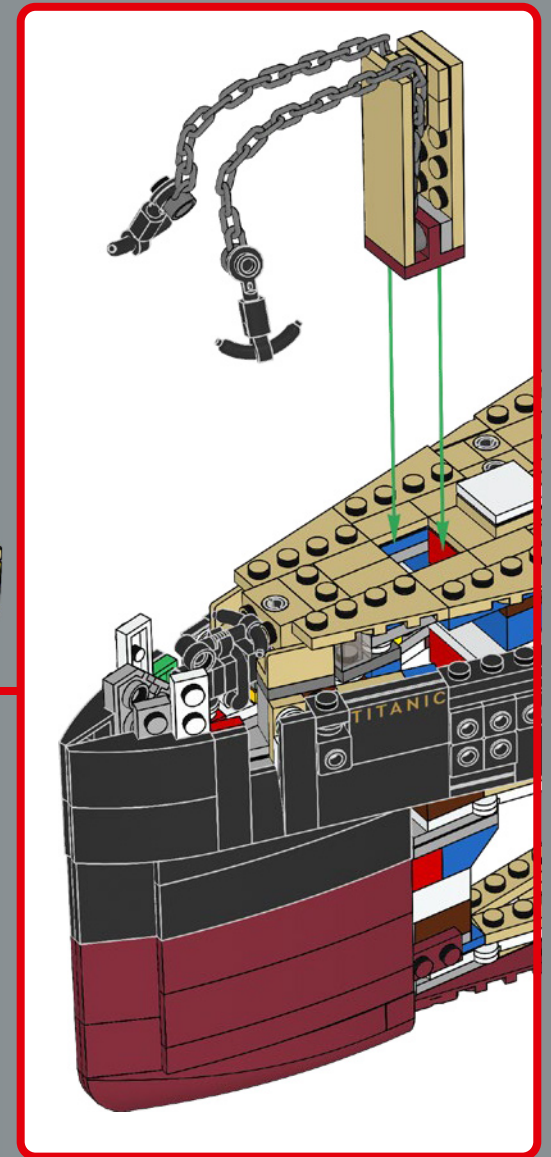
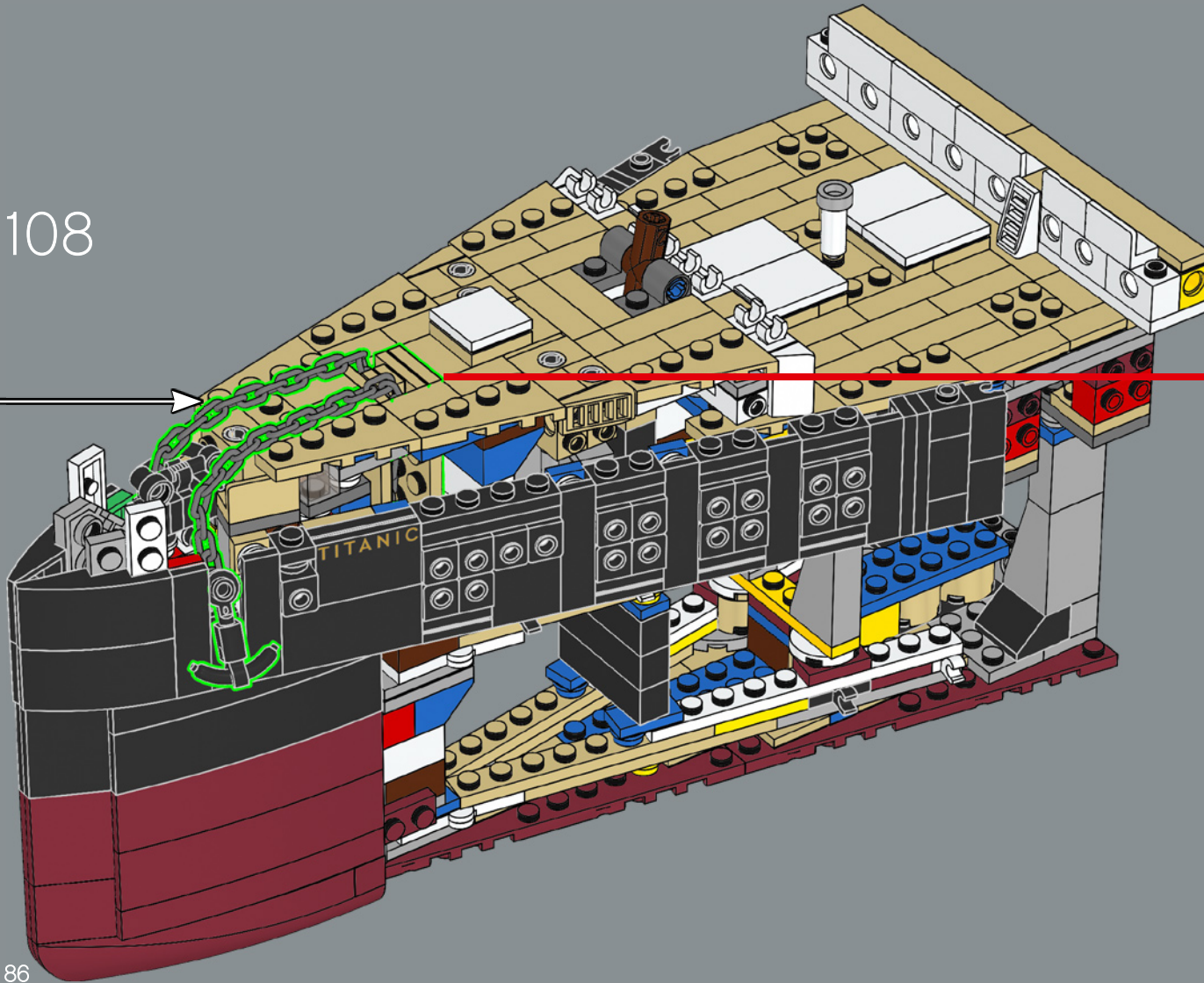

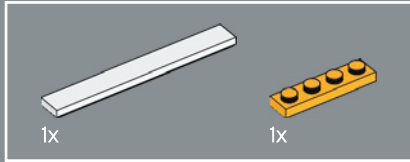
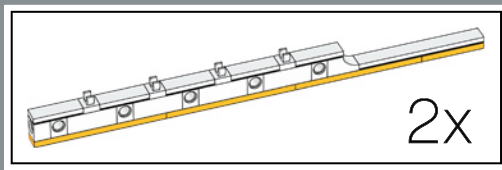

109

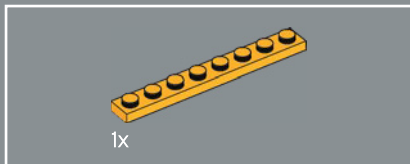
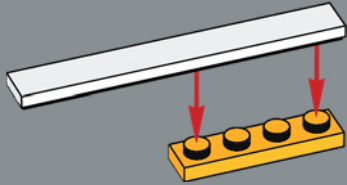

110

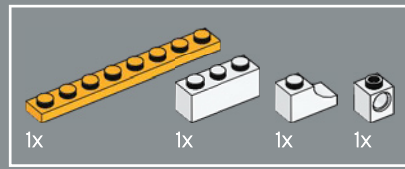
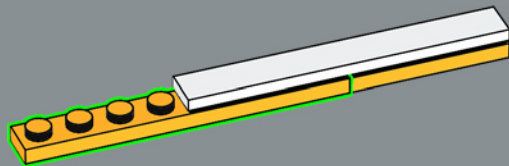

111

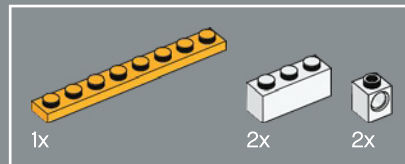
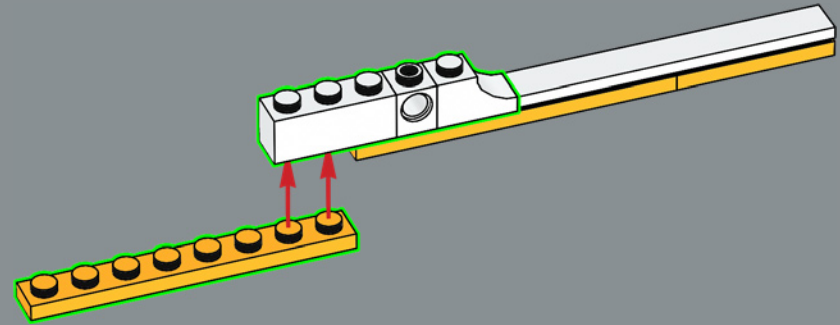

112

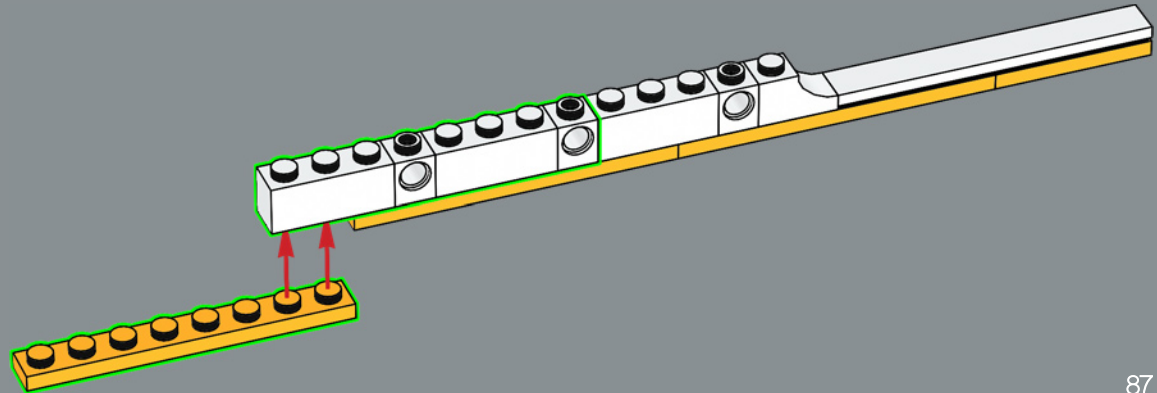

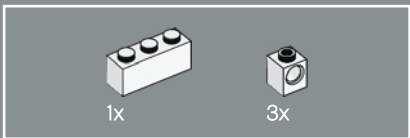

113

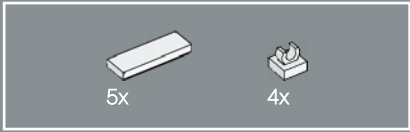
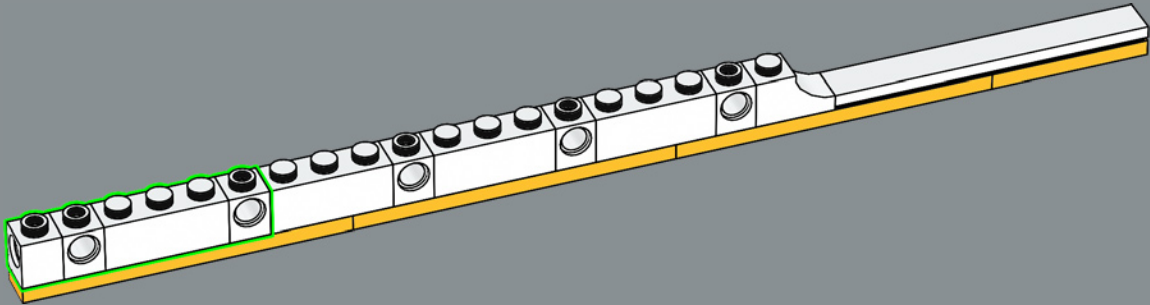

114

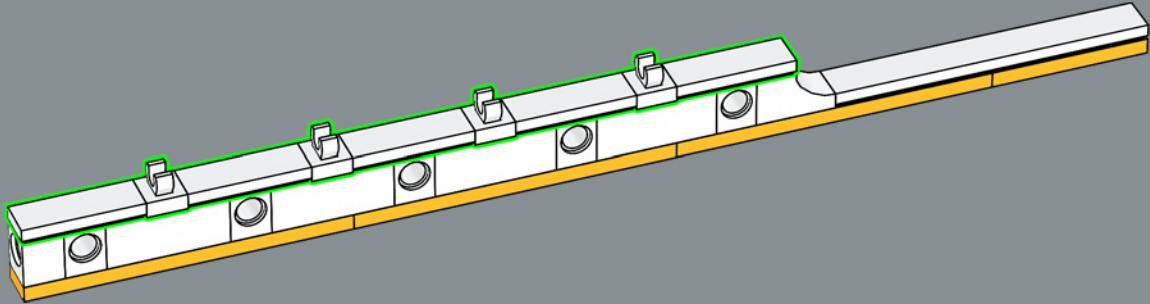

2x

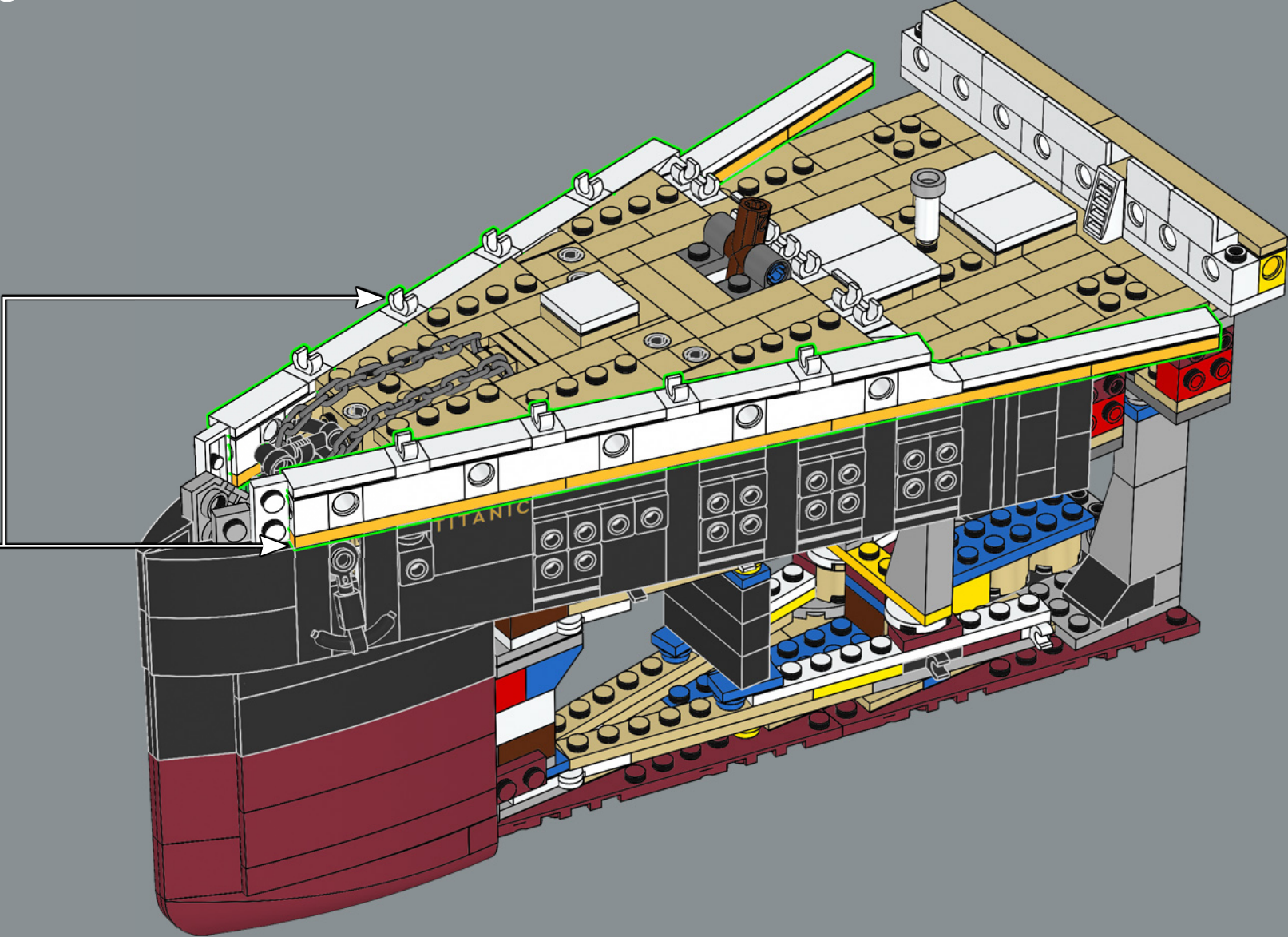

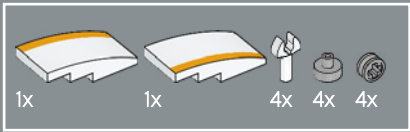

116

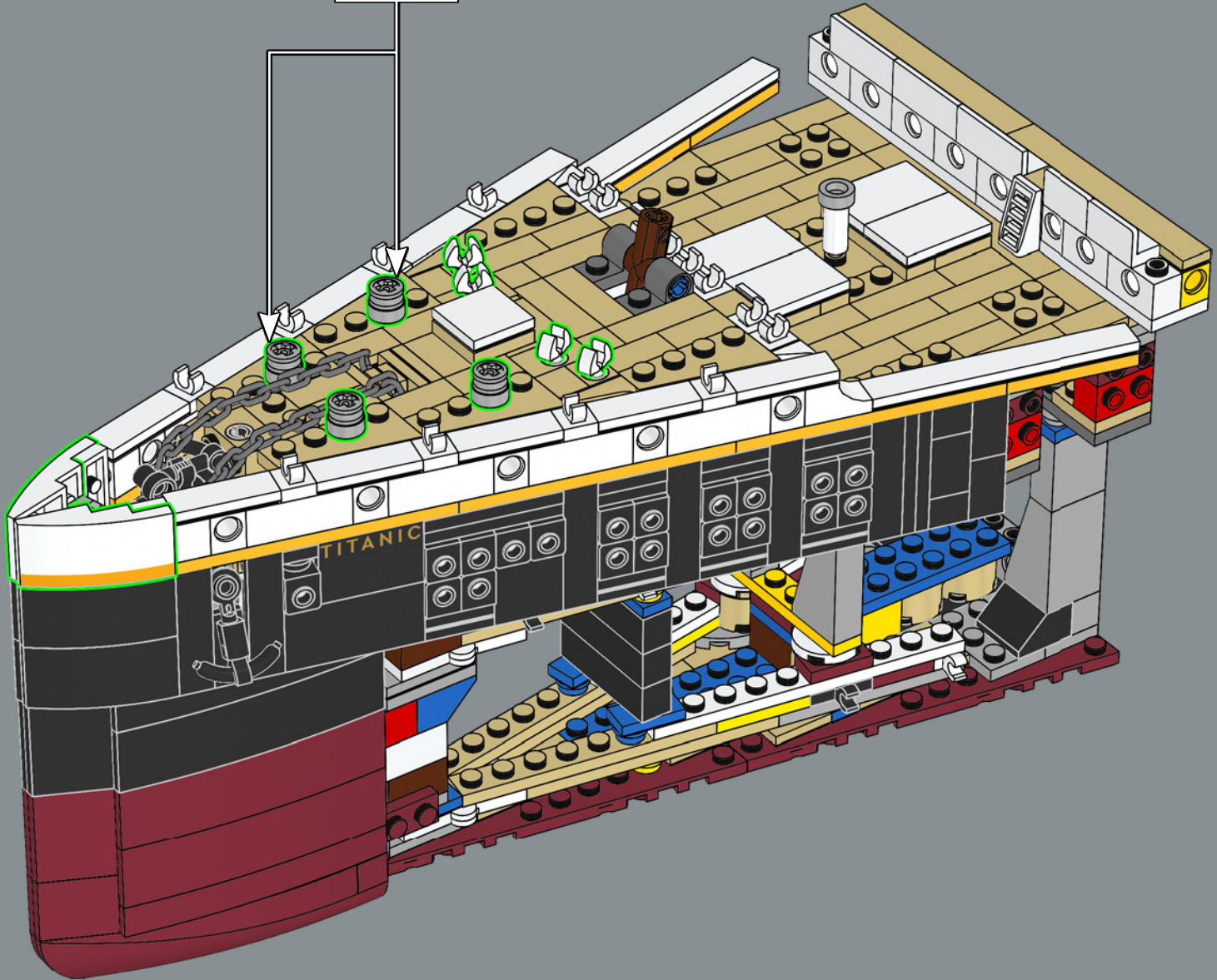
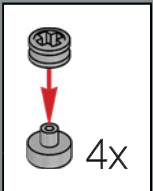

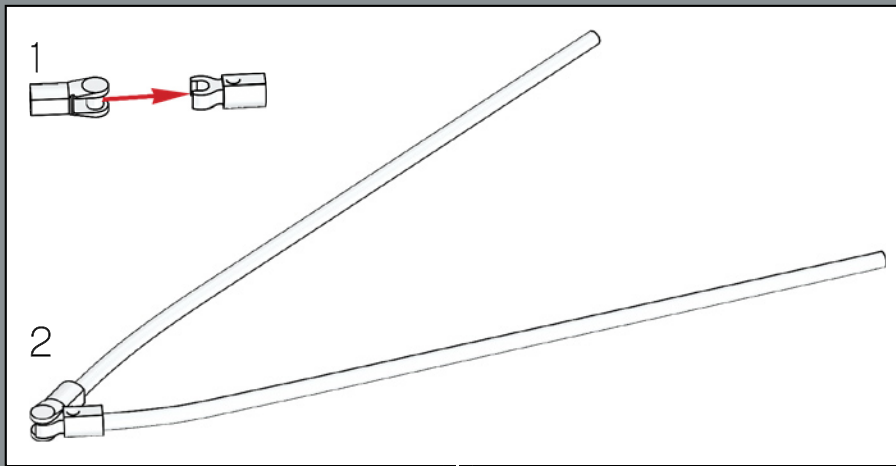
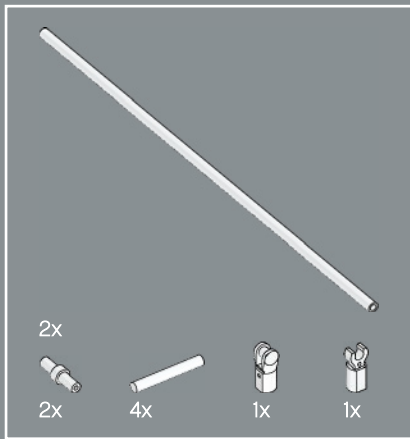

117

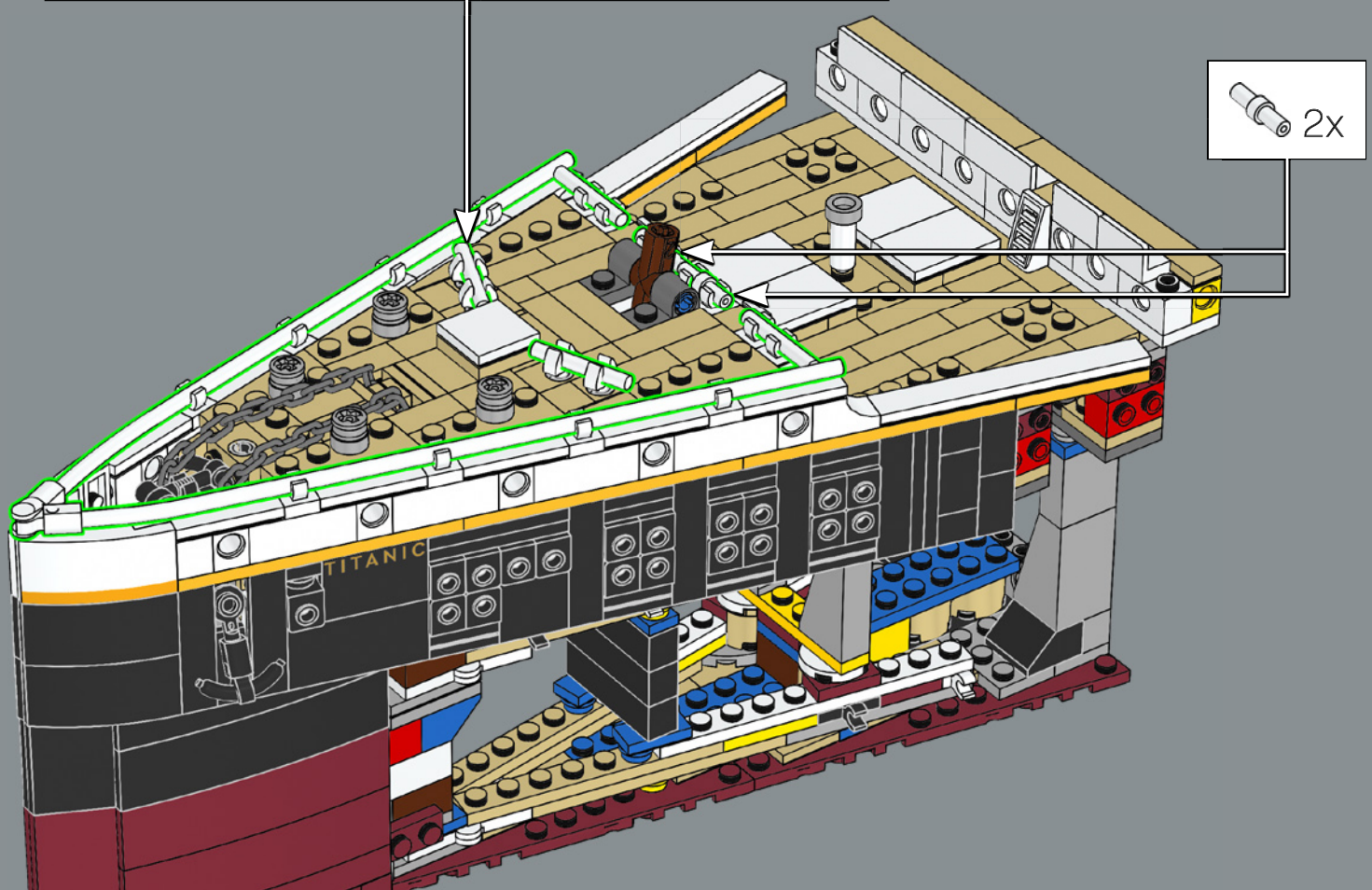
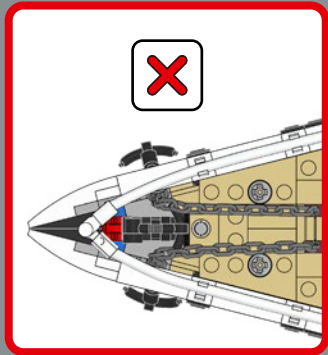
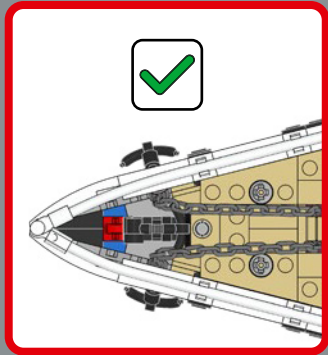



118

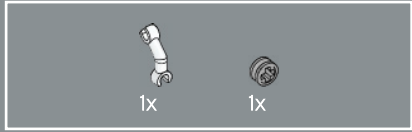

119



120

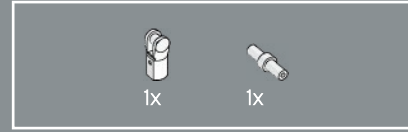
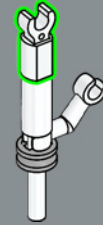

121

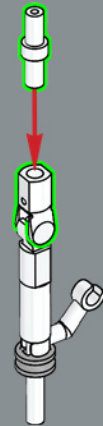



122

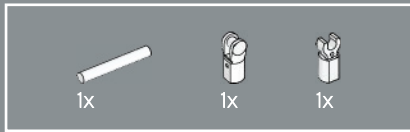
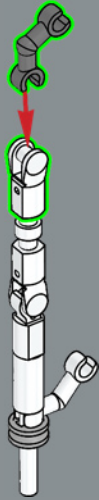

123

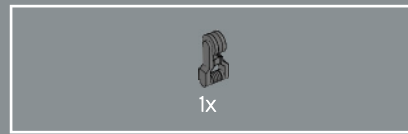
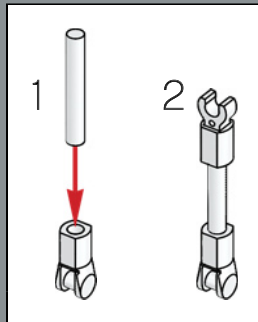
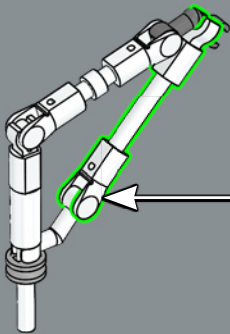

124

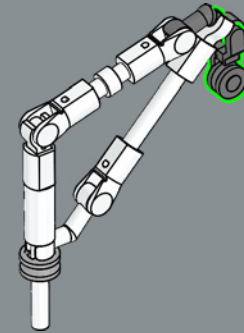

125

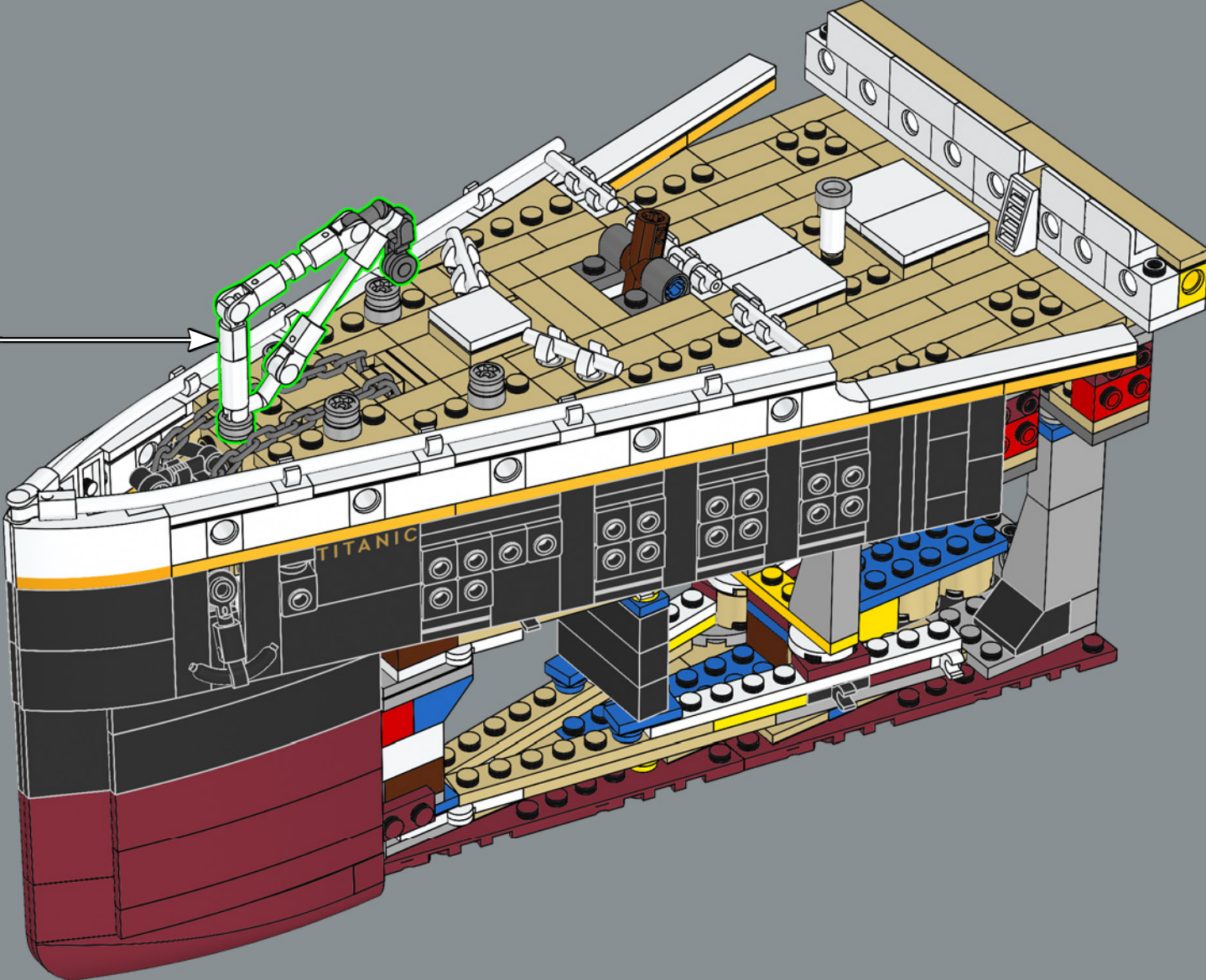

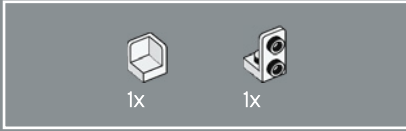
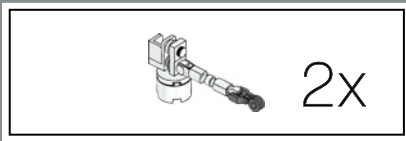

126

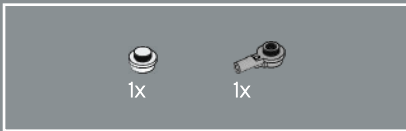

127

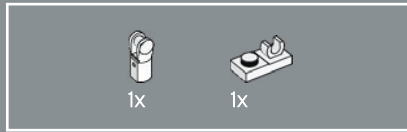

128

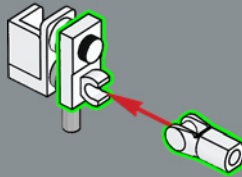

129

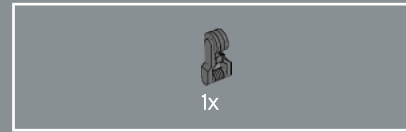
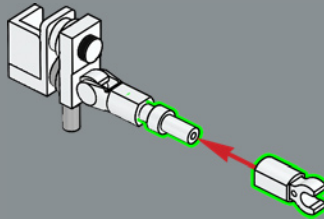

130

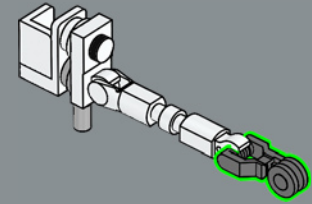

131

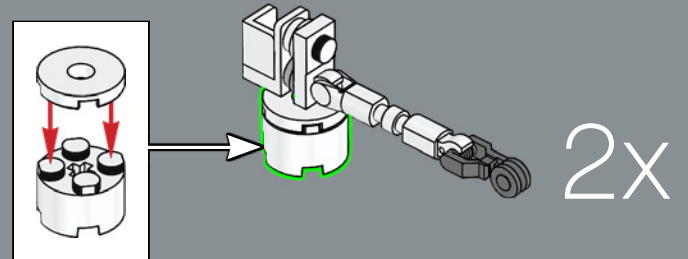

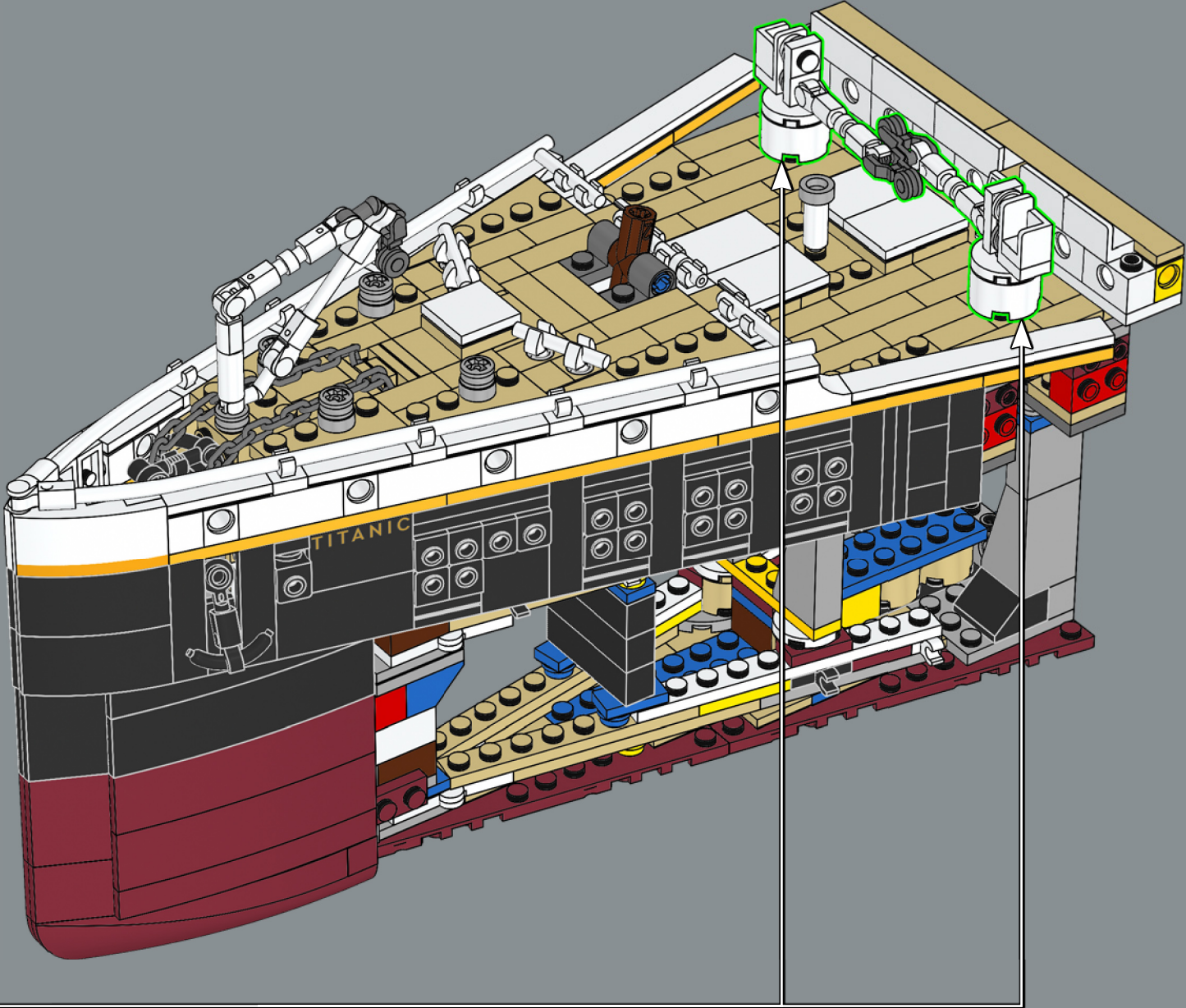

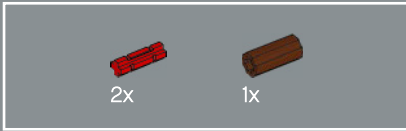
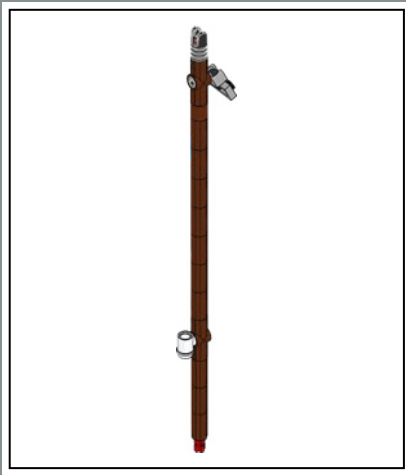

133

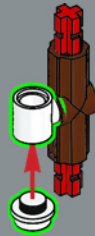

134

1x

1x



135

9x

9x

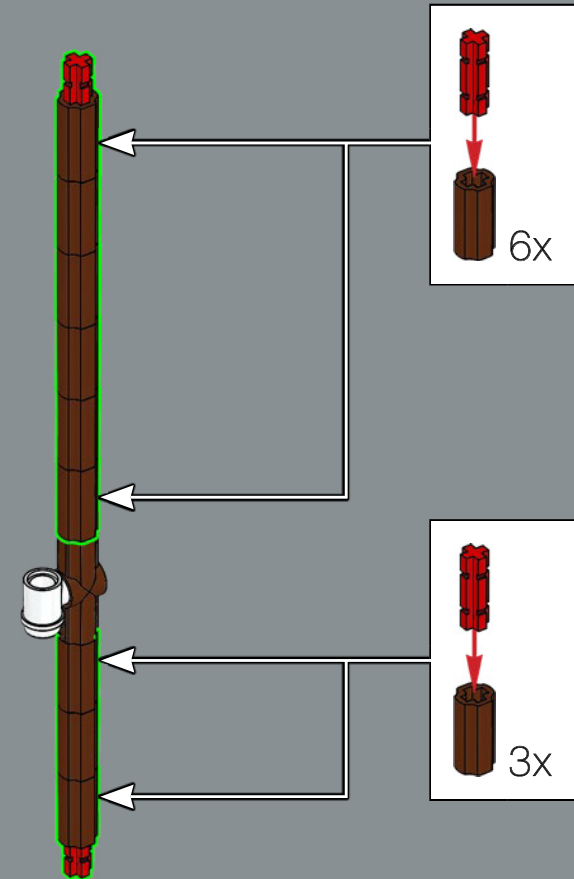

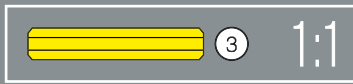
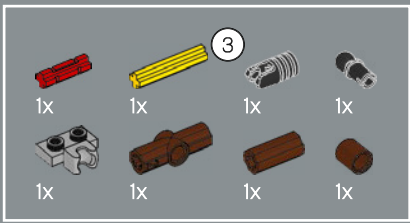

136

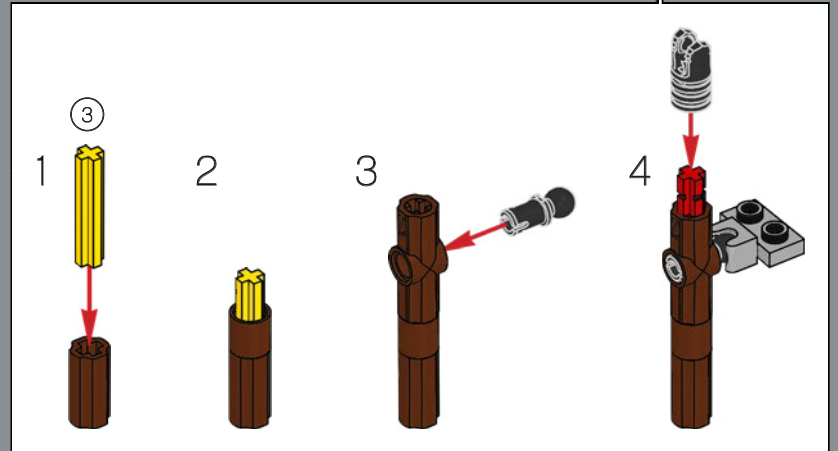

137

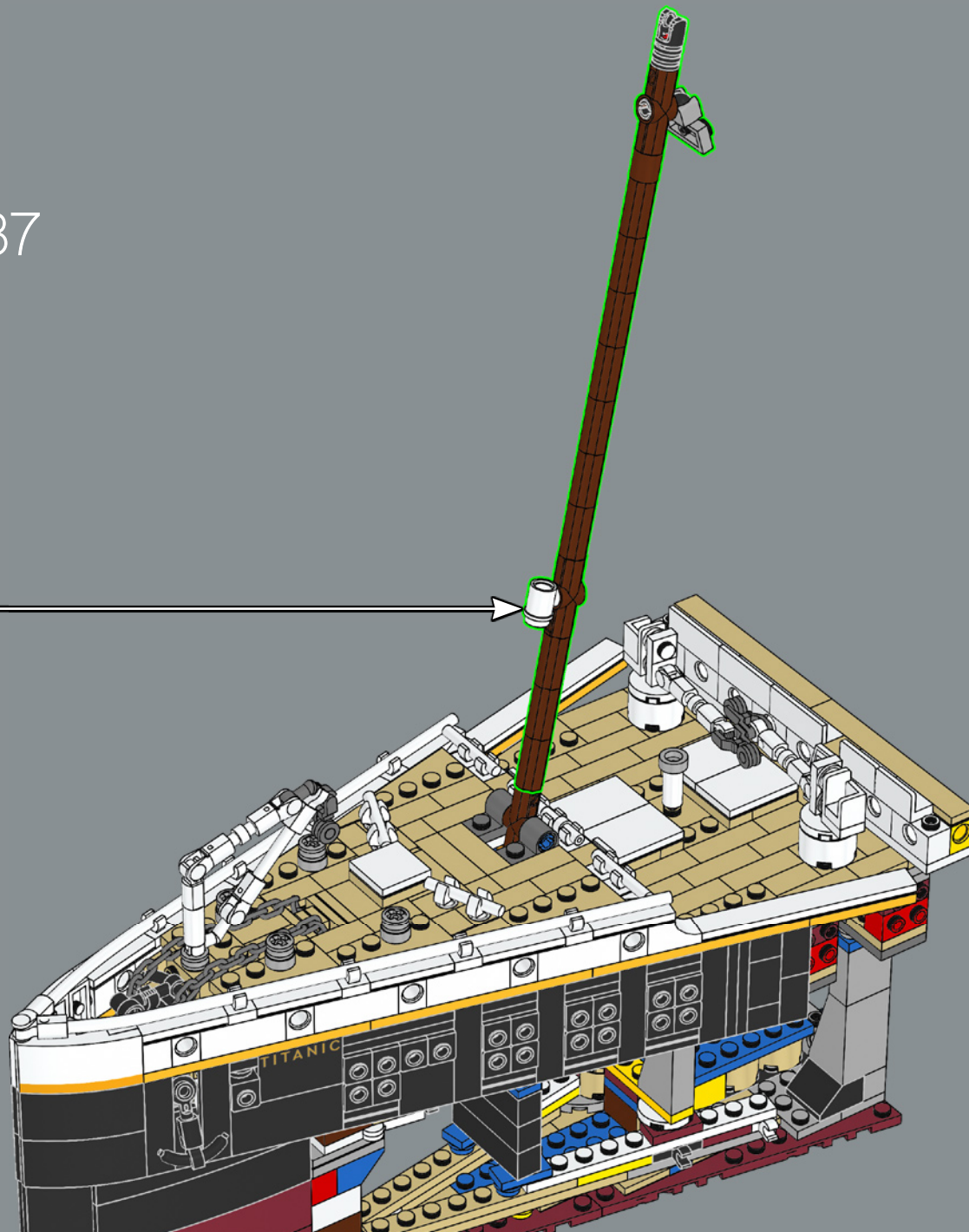

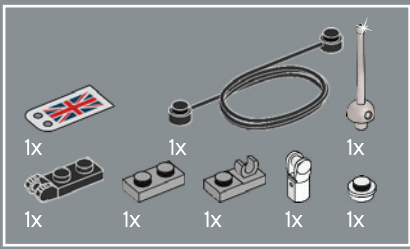

138

1

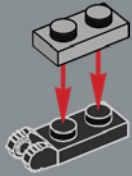

2

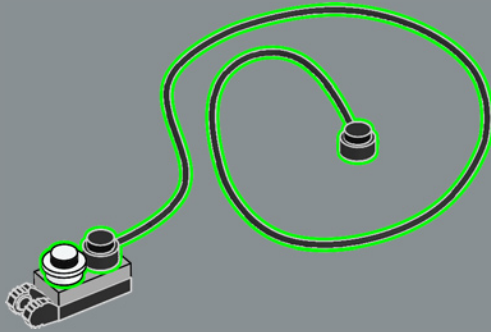

3

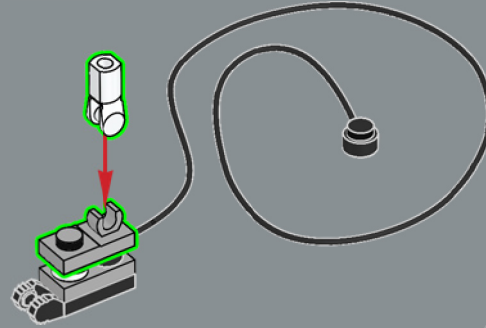

4

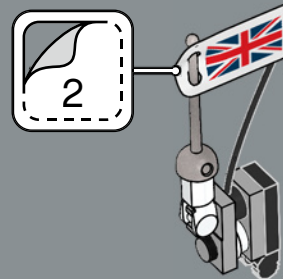

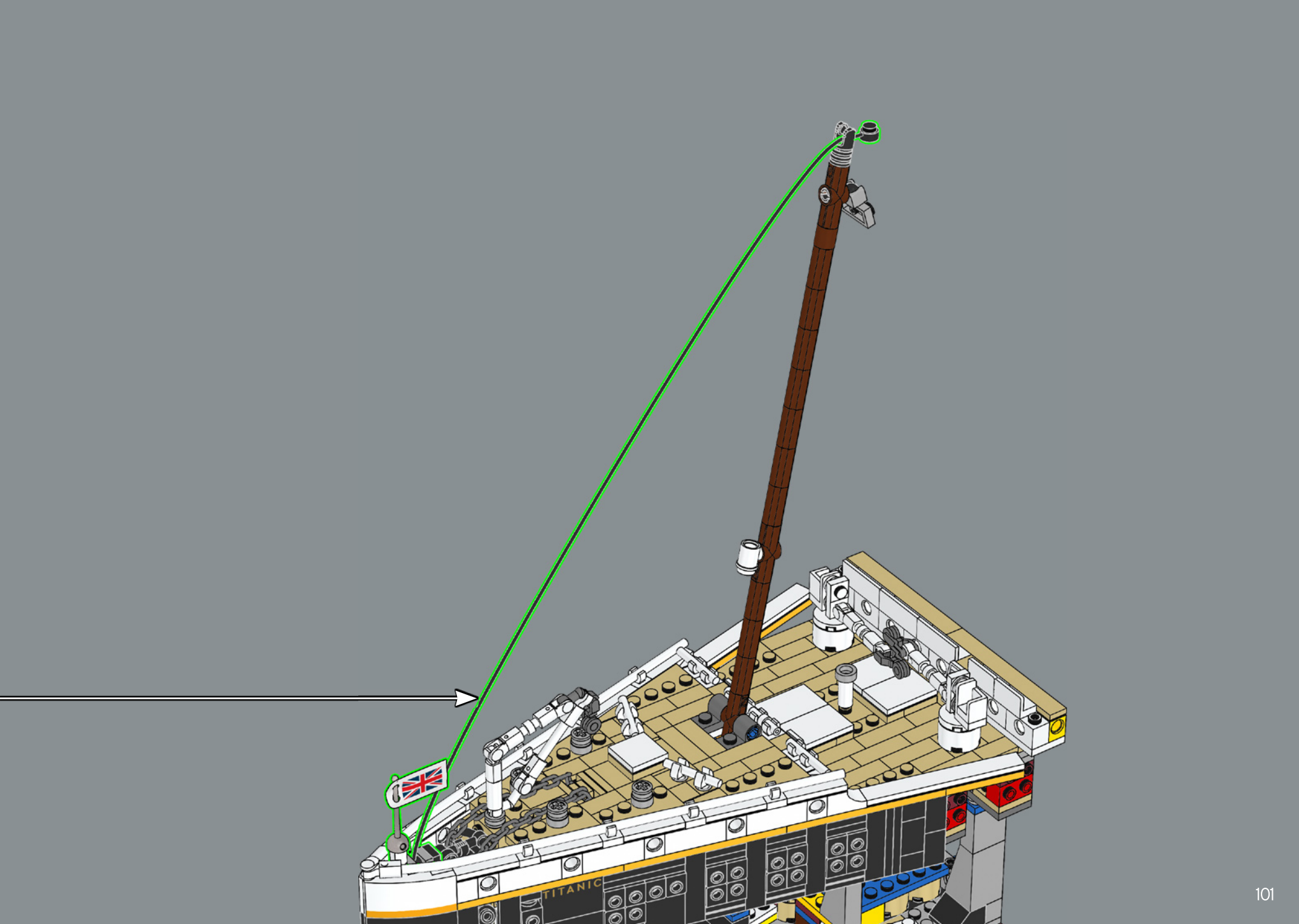

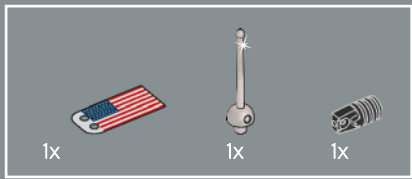

139

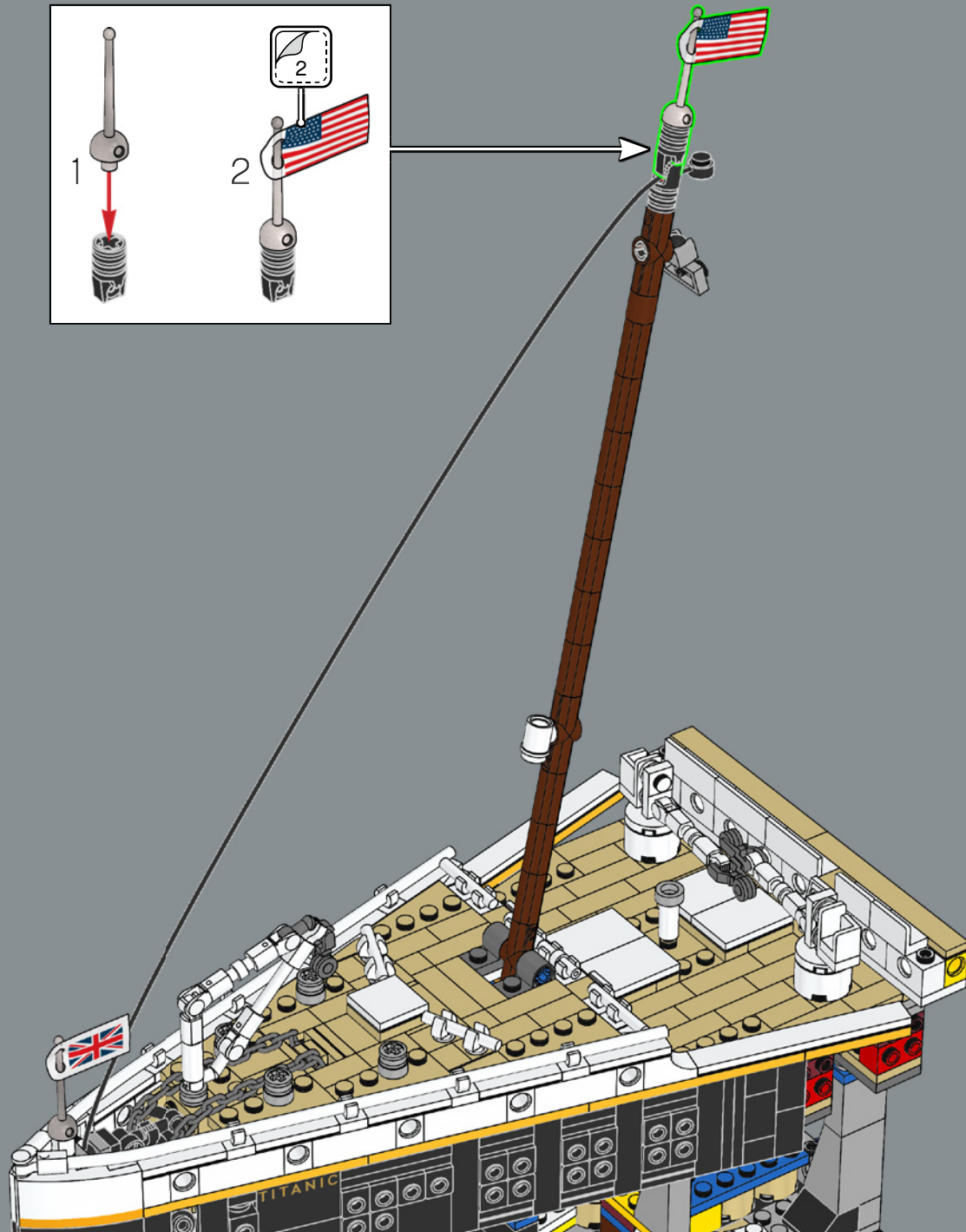
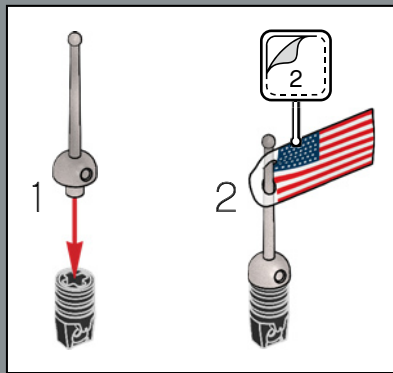

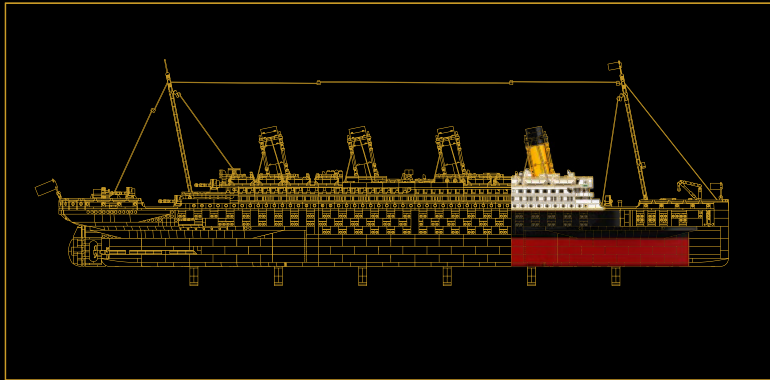

SEZIONE 2:

PONTE E FUMAIOLO

In questa seconda sezione, lo scafo raggiunge la sua larghezza massima, 18 moduli o 144 mm. La costruzione della sezione trasversale della nave, tra cui la piscina, il grande scalone e uno dei locali caldaie del *Titanic*, viene avviata qui, all'interno dello scafo. Sarà inoltre possibile costruire il famoso cassero centrale e il primo dei quattro fumaioli.

↓ Un meccanismo celato all'interno del grande scalone consente all'intera nave di essere collegata e bloccata saldamente insieme.



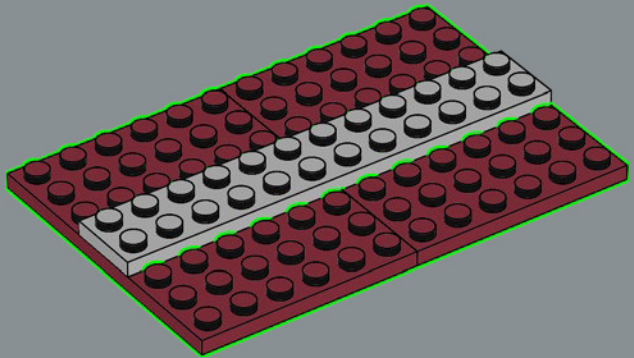
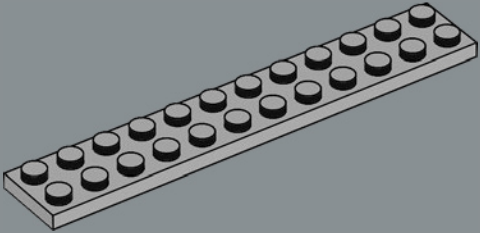
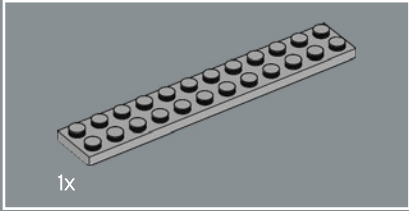
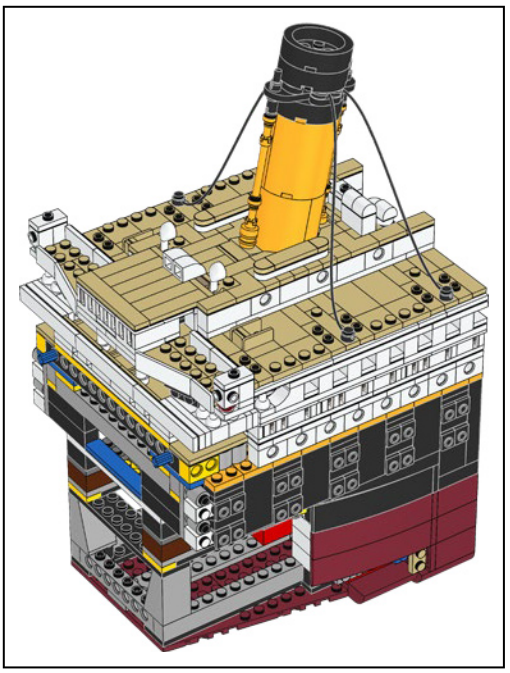
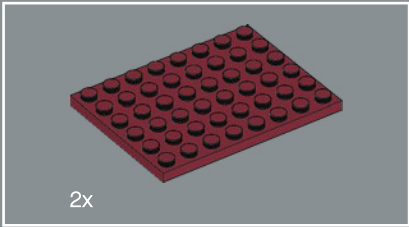
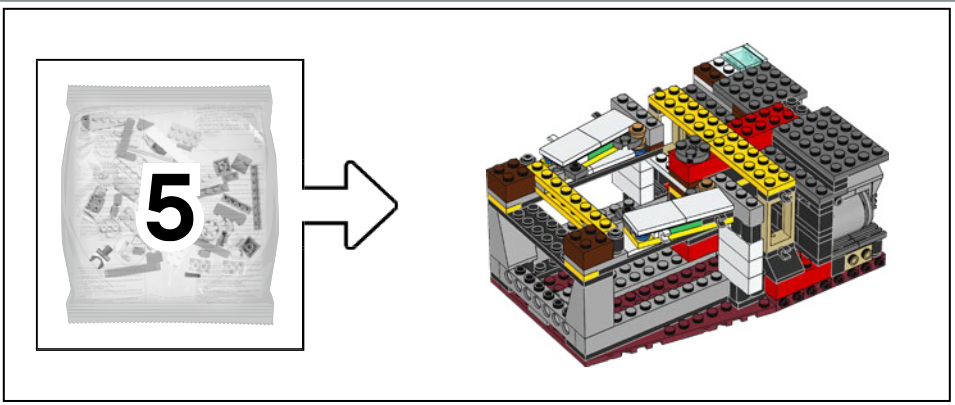

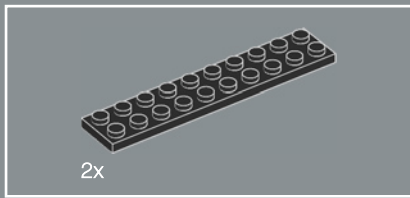

142

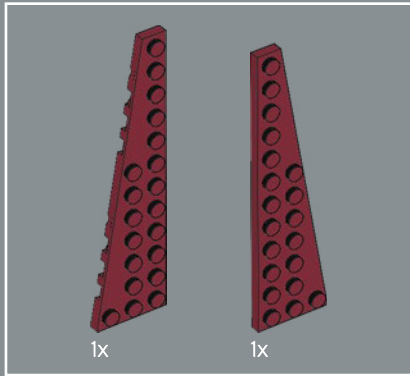
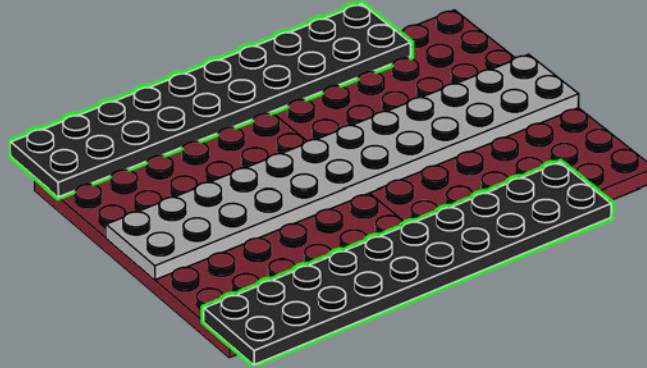

143

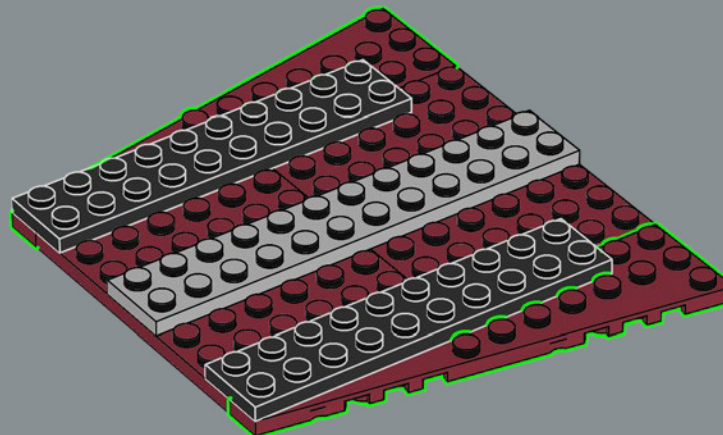

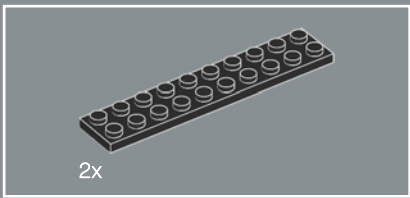

144

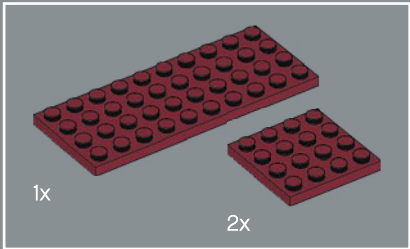
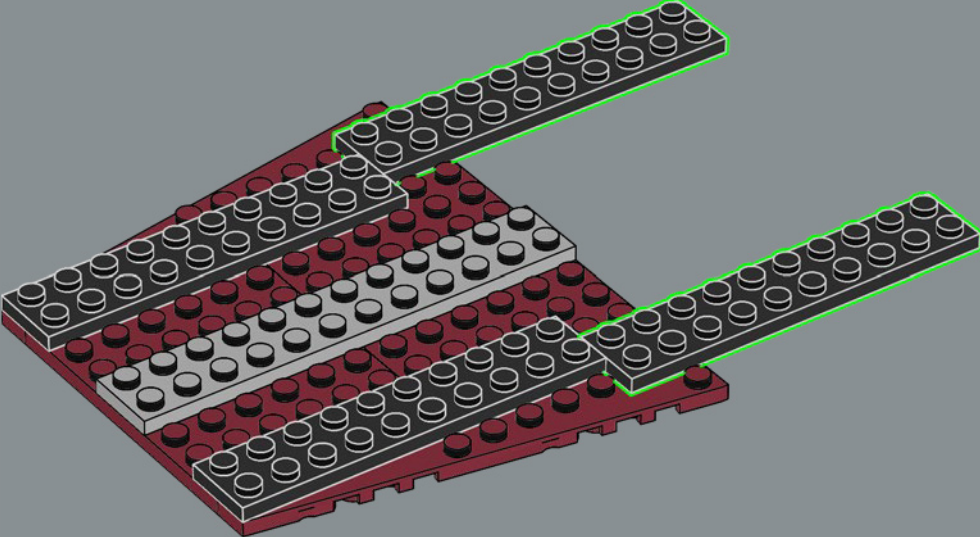

145

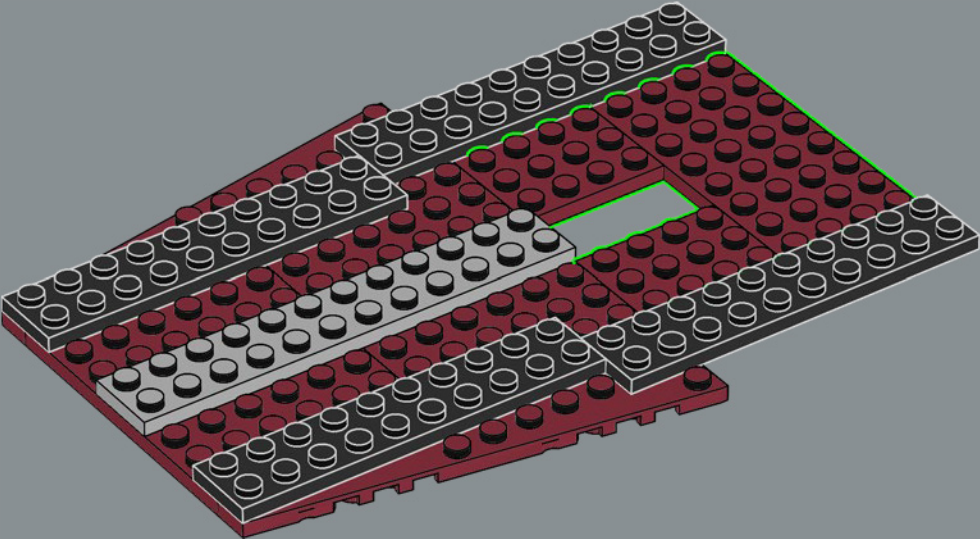

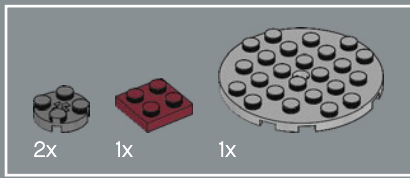

146

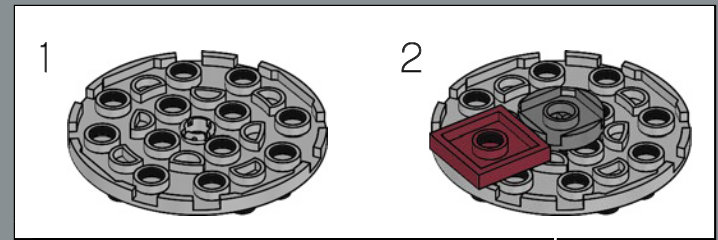
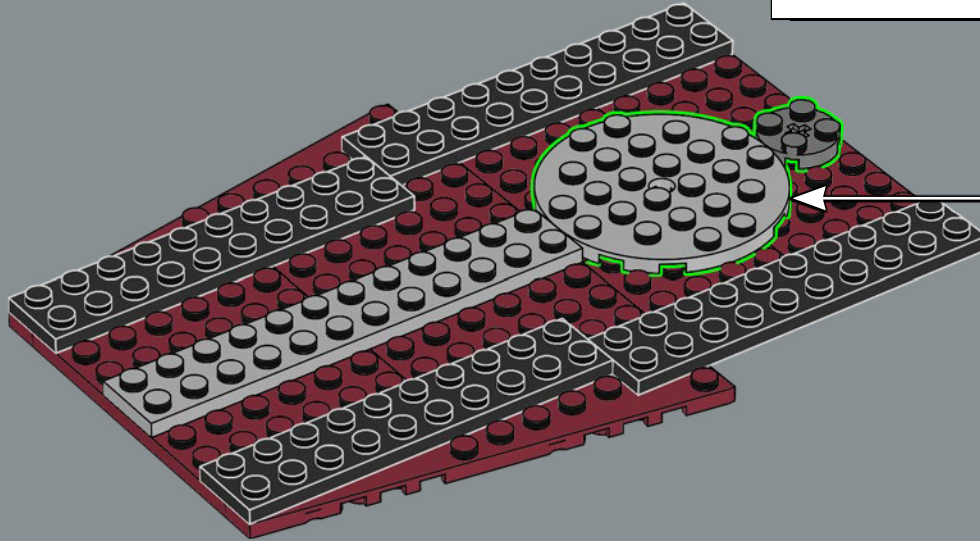

147

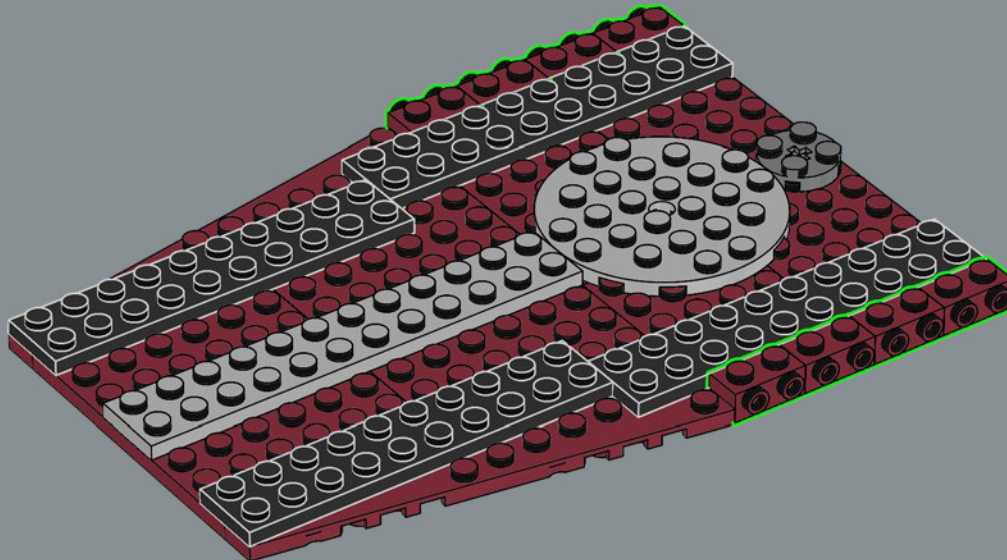

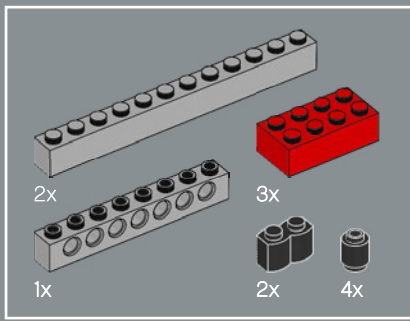

149

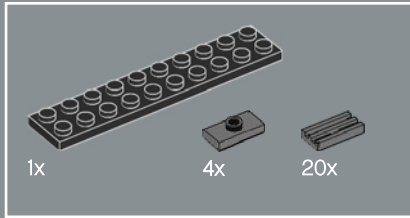
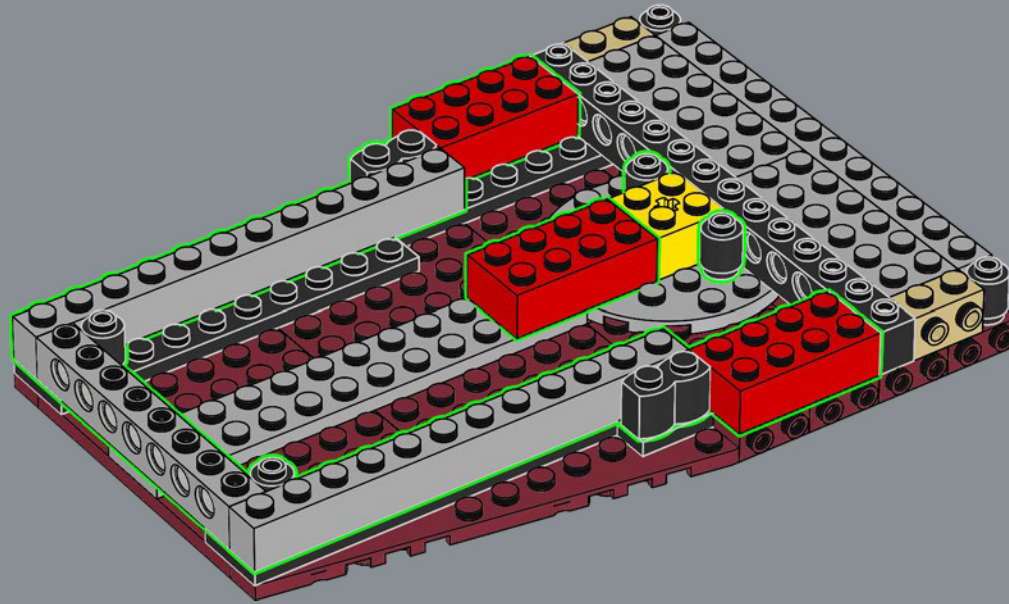

150

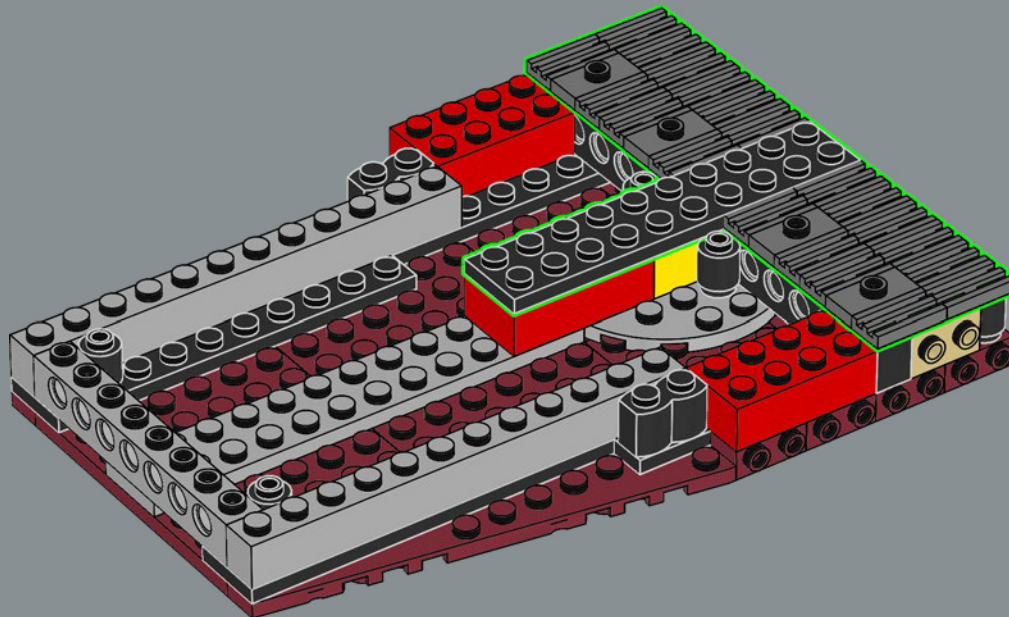

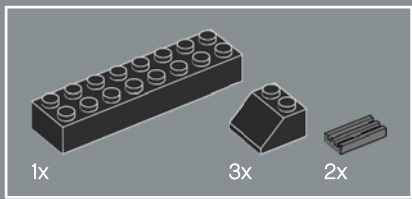

151

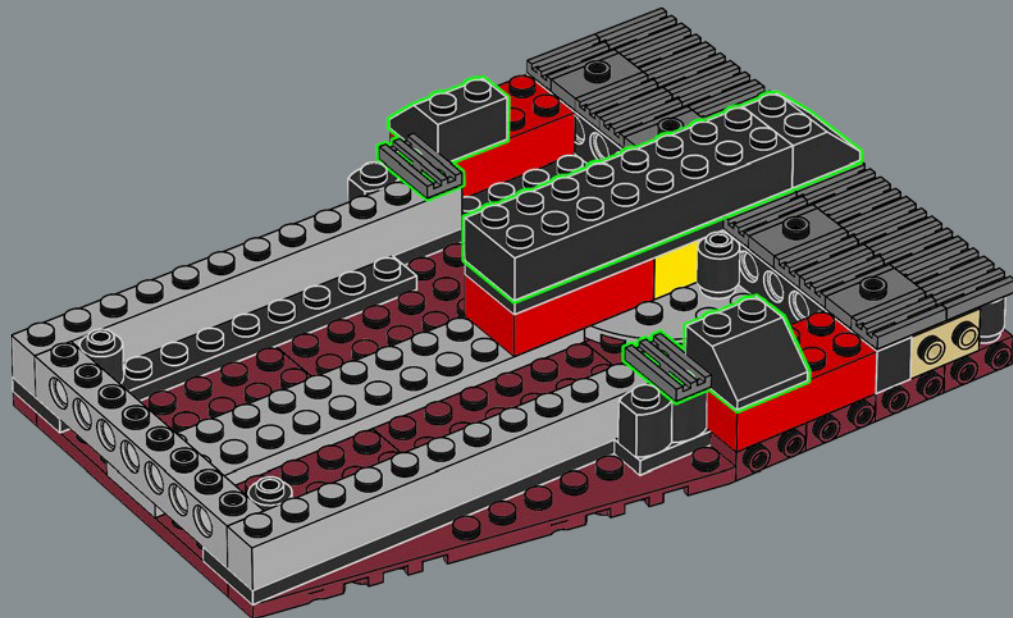

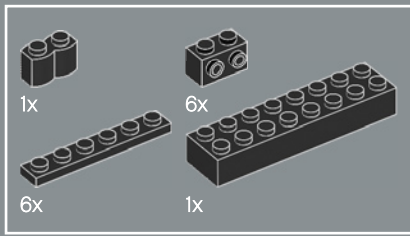

152

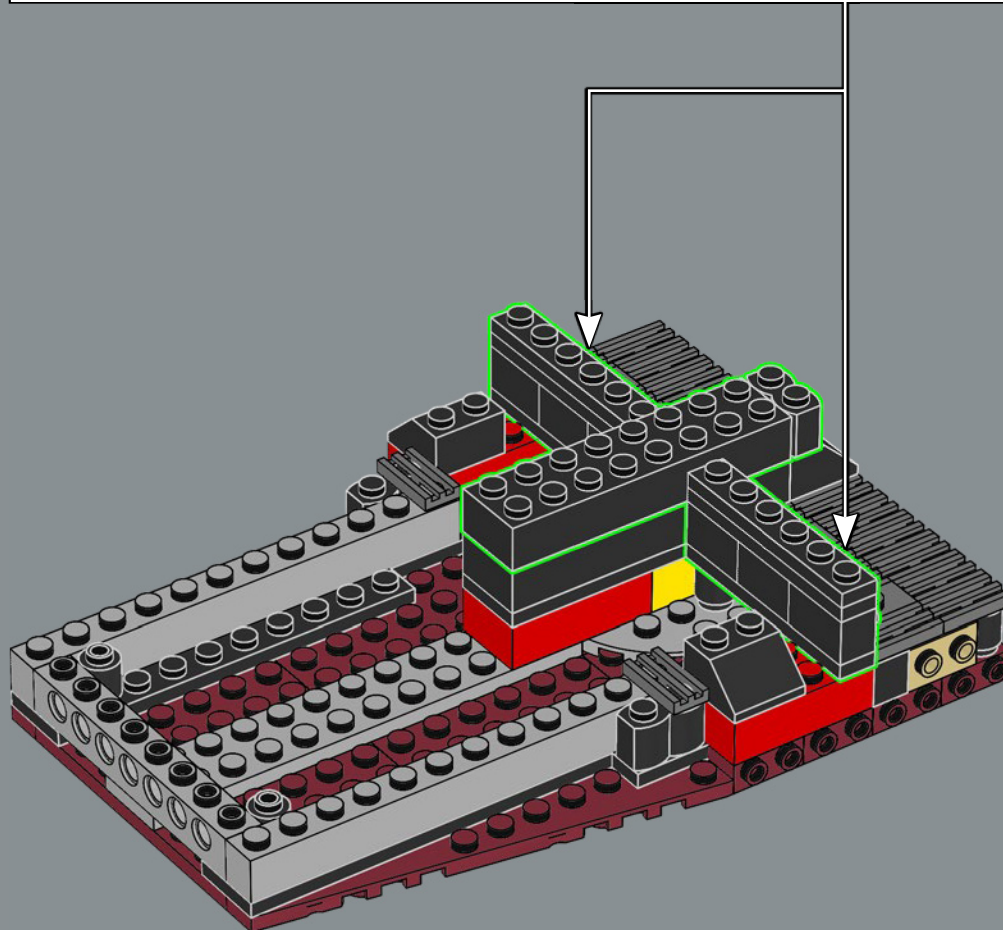
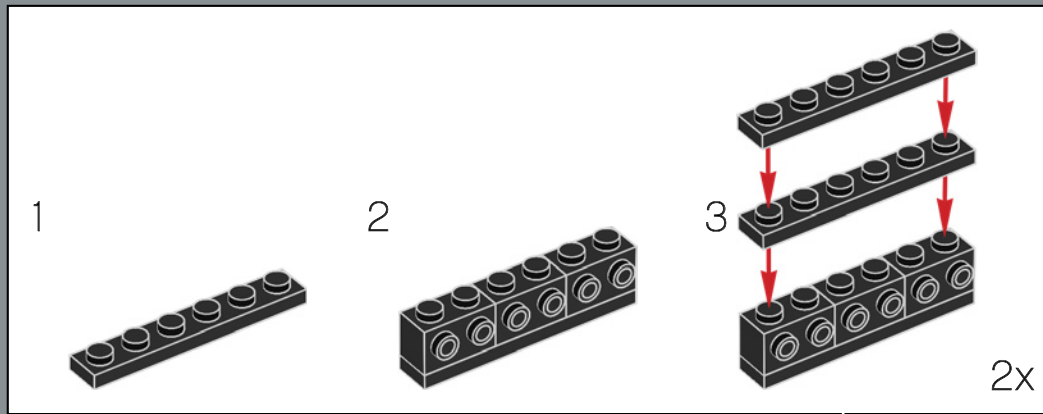

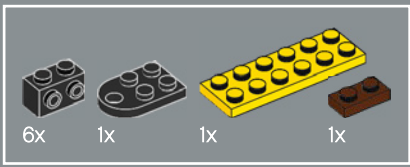

153

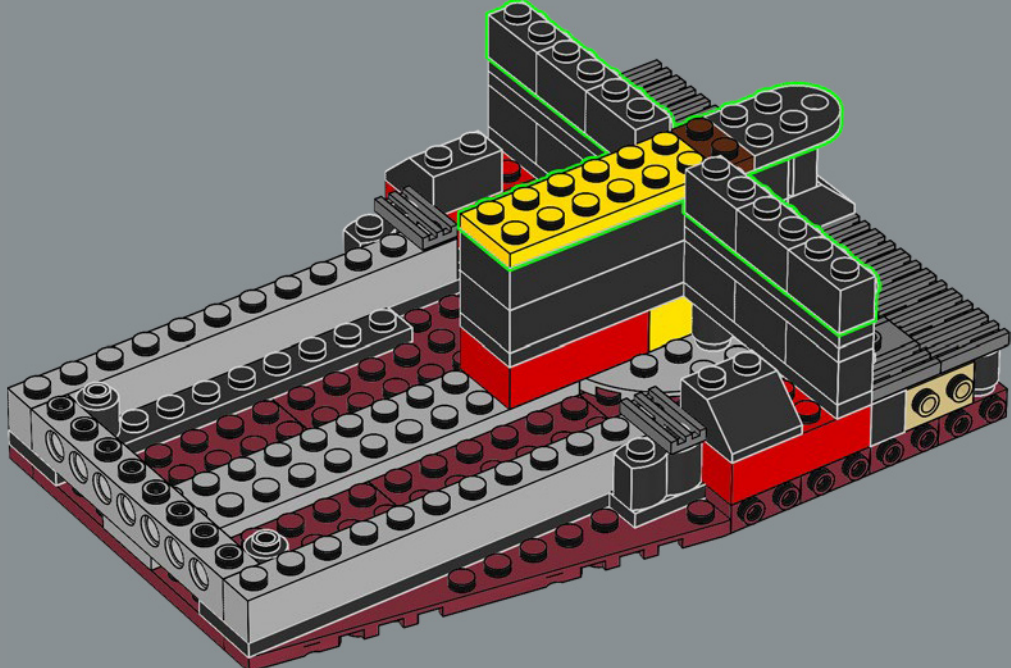

175 fuochisti lavoravano costantemente per
spalare carbone nelle caldaie dei motori.

154

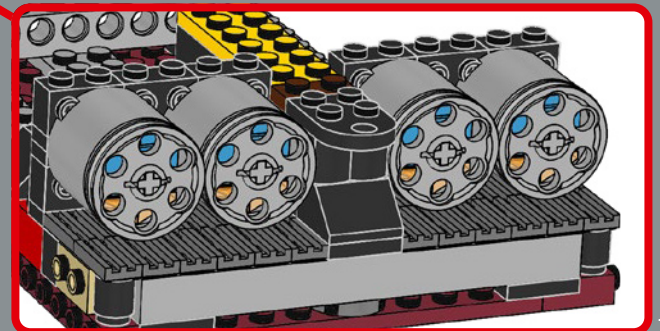
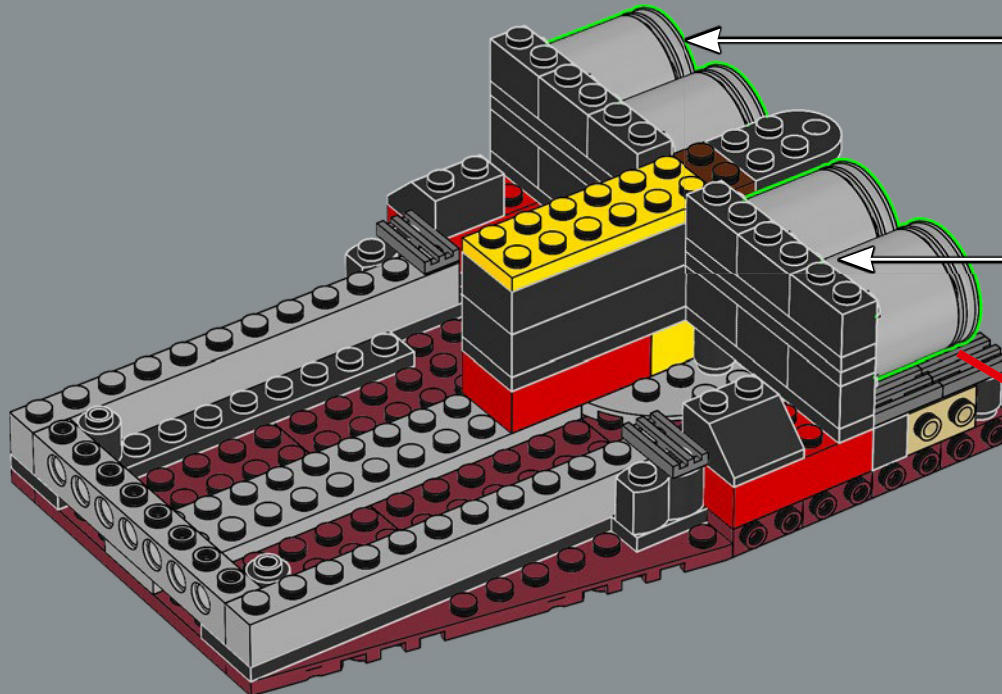
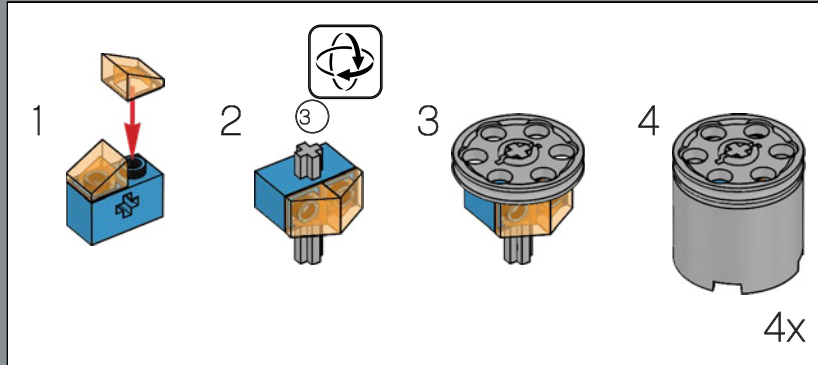
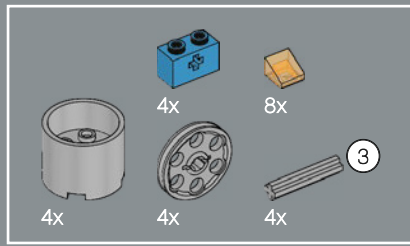

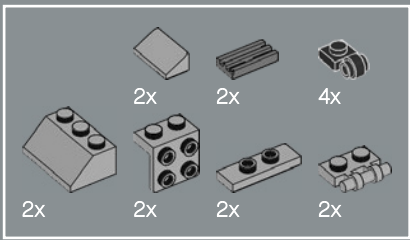

155

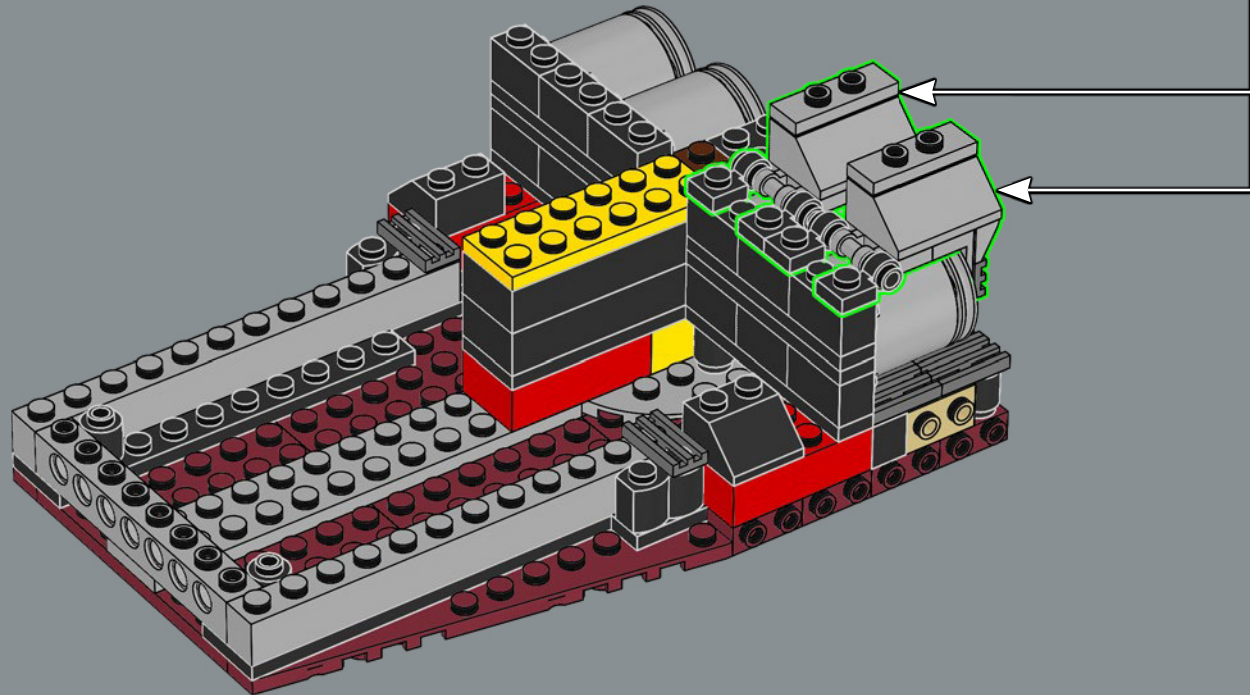
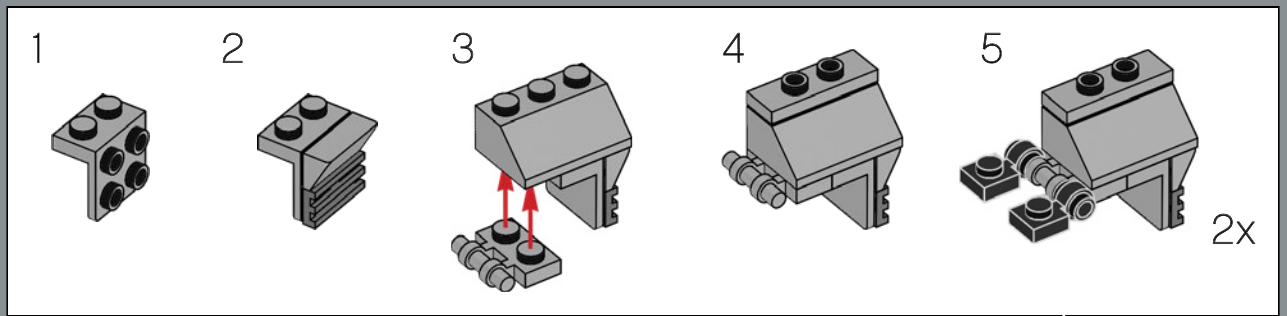

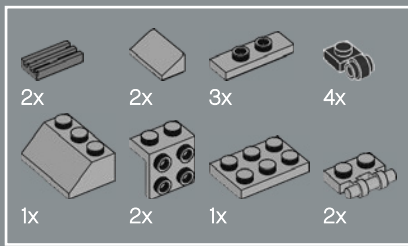

156

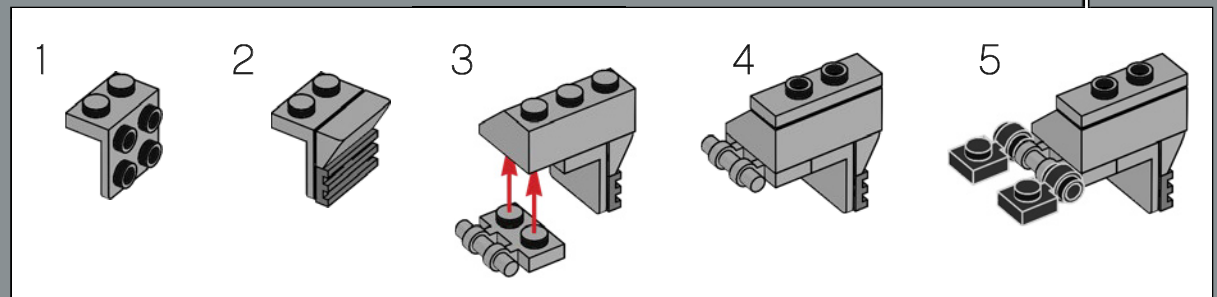
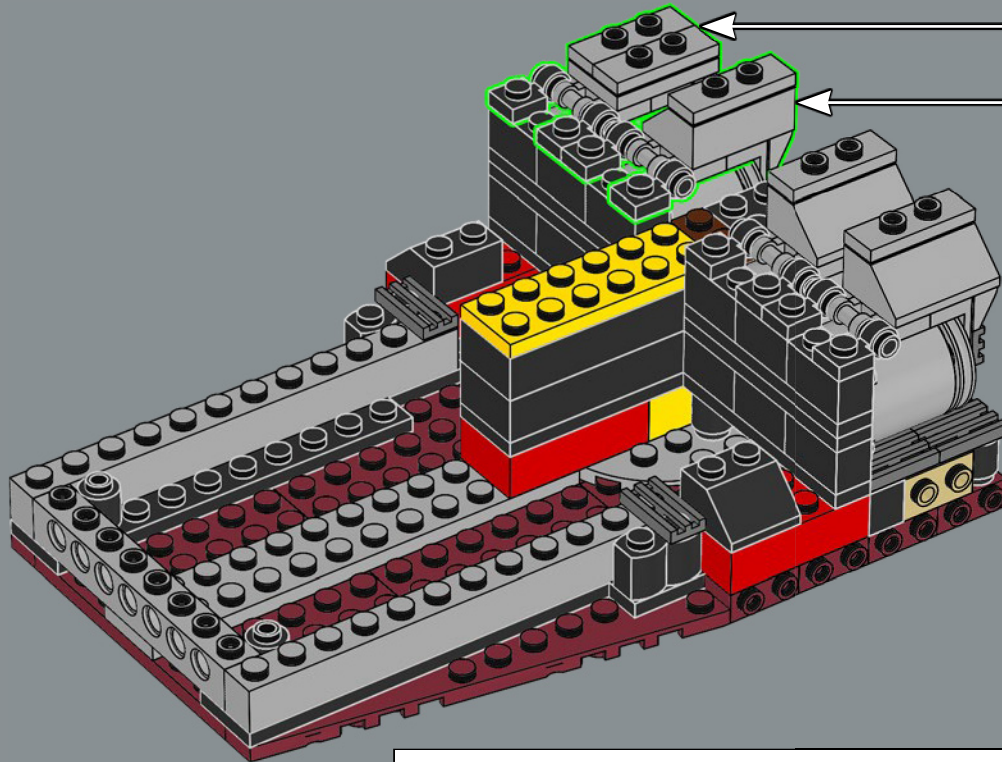
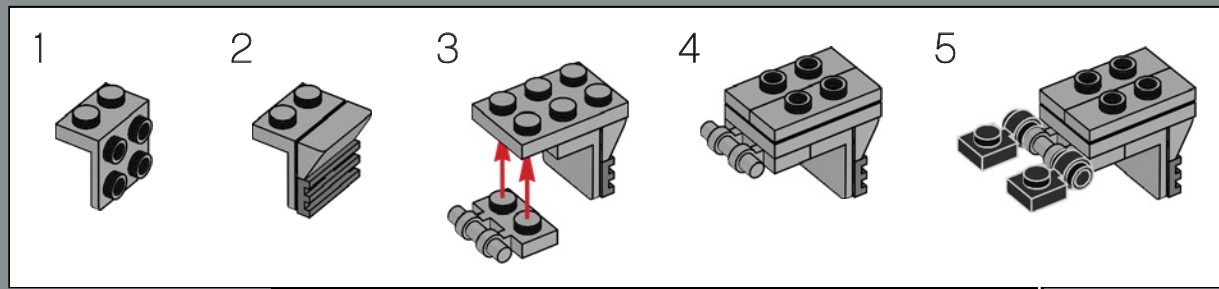

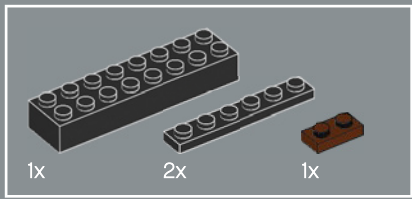

157

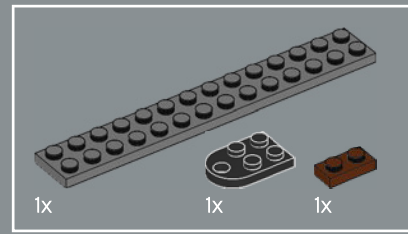
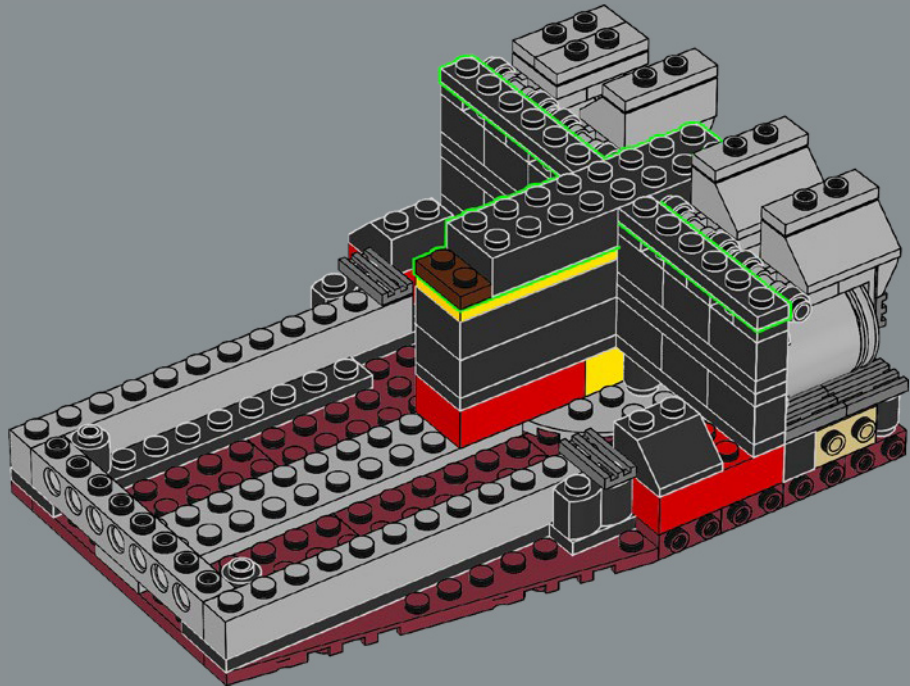

158

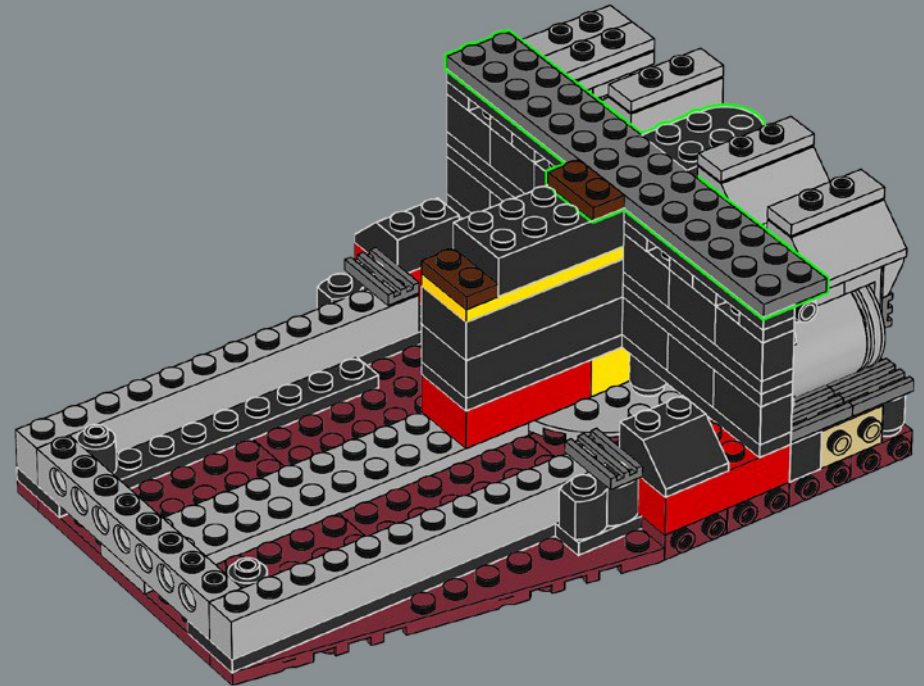

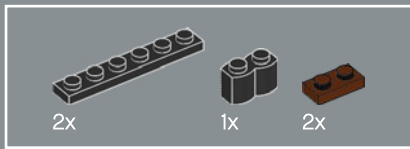

159

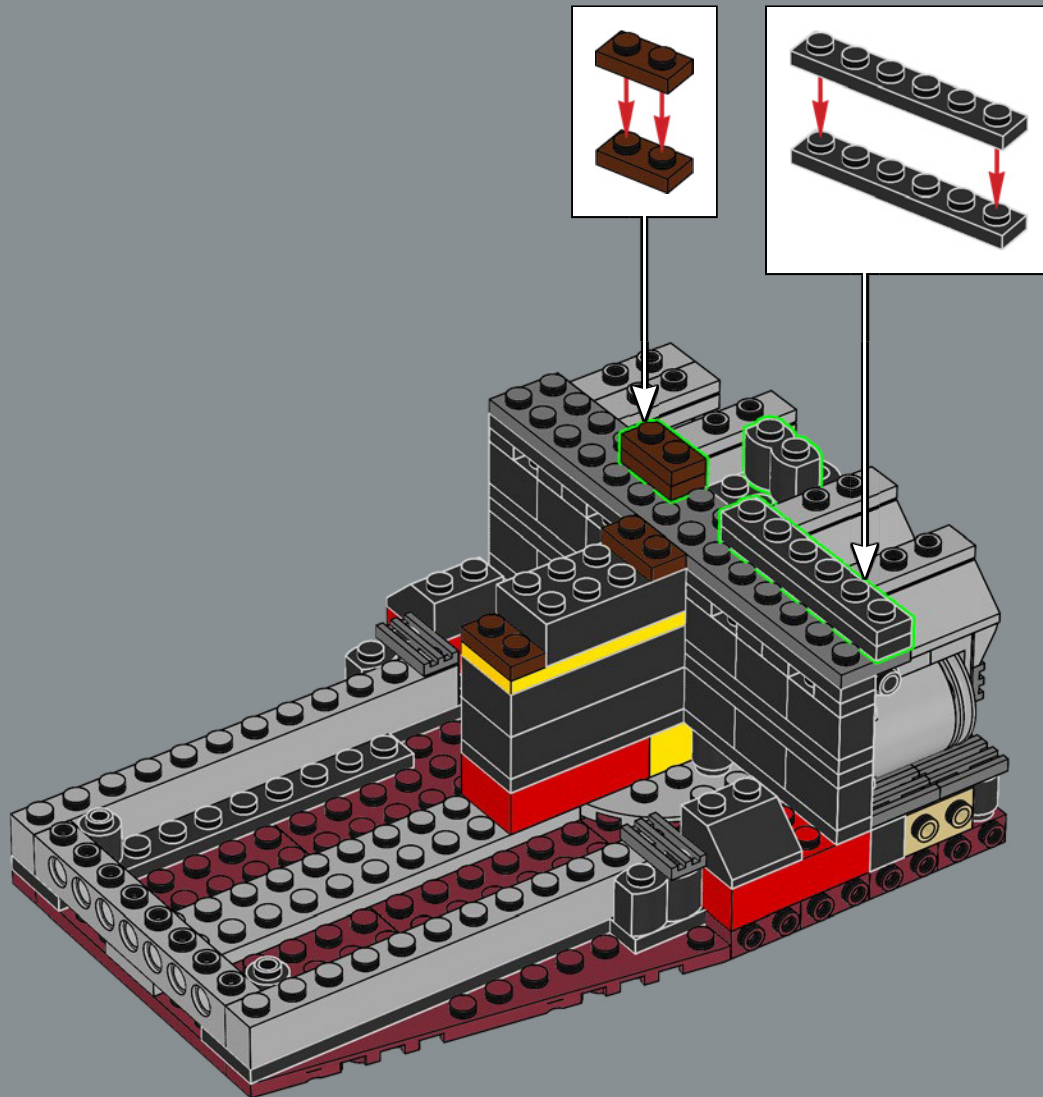

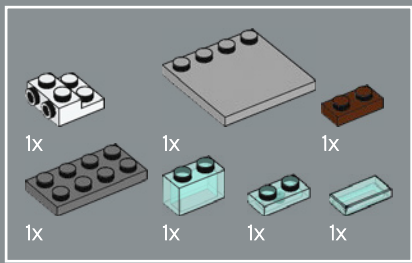

160

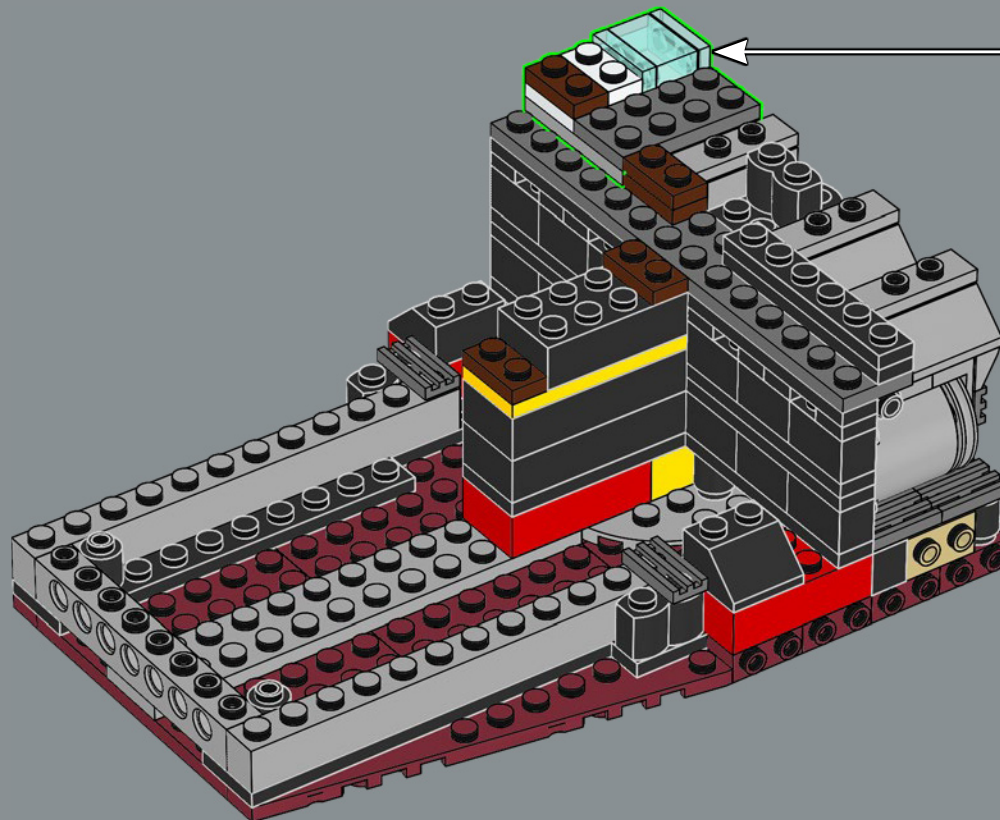
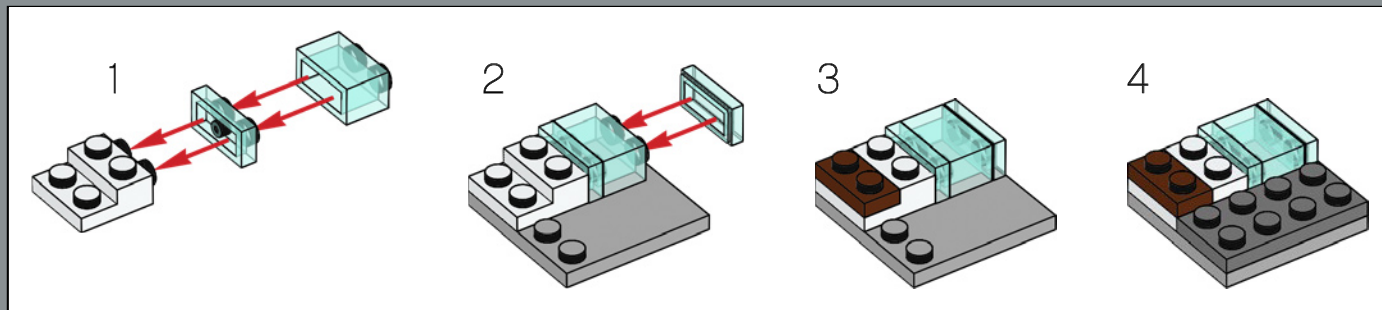

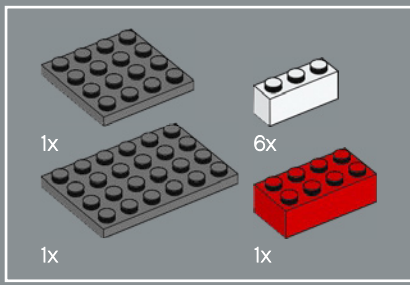

161

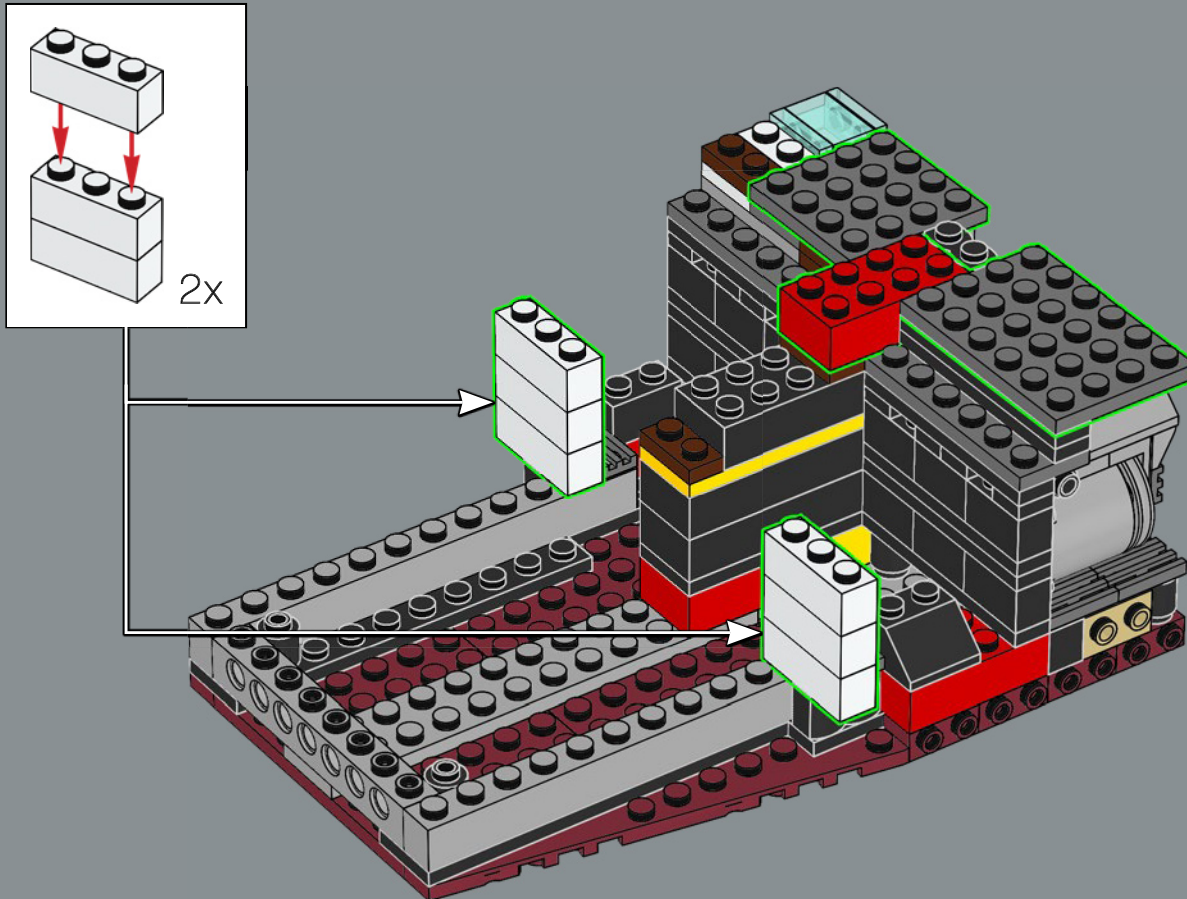

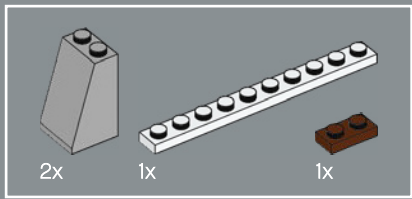

162

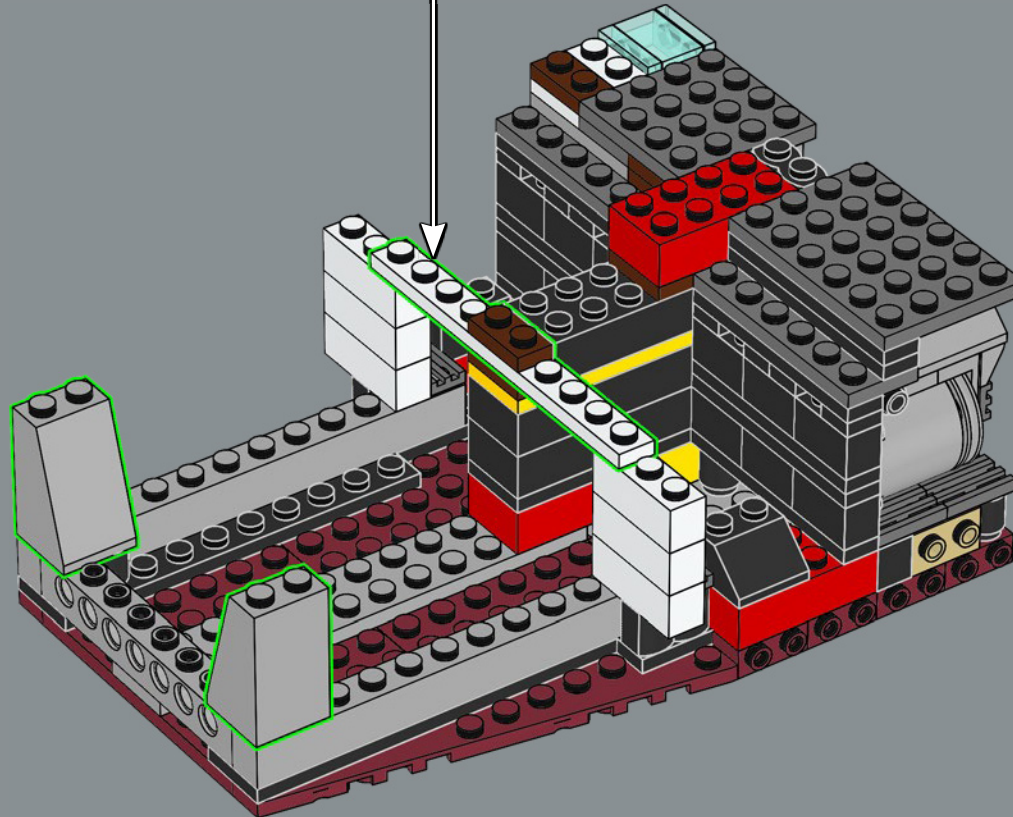
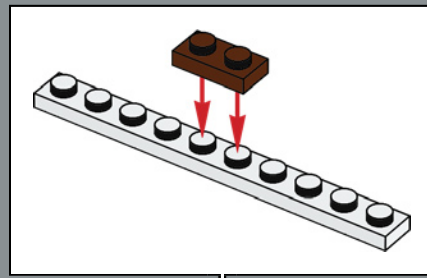

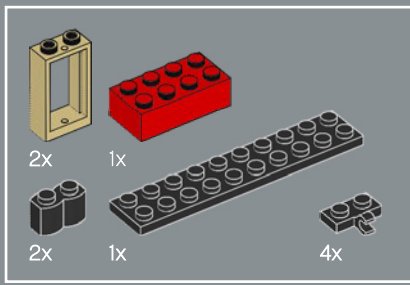

163

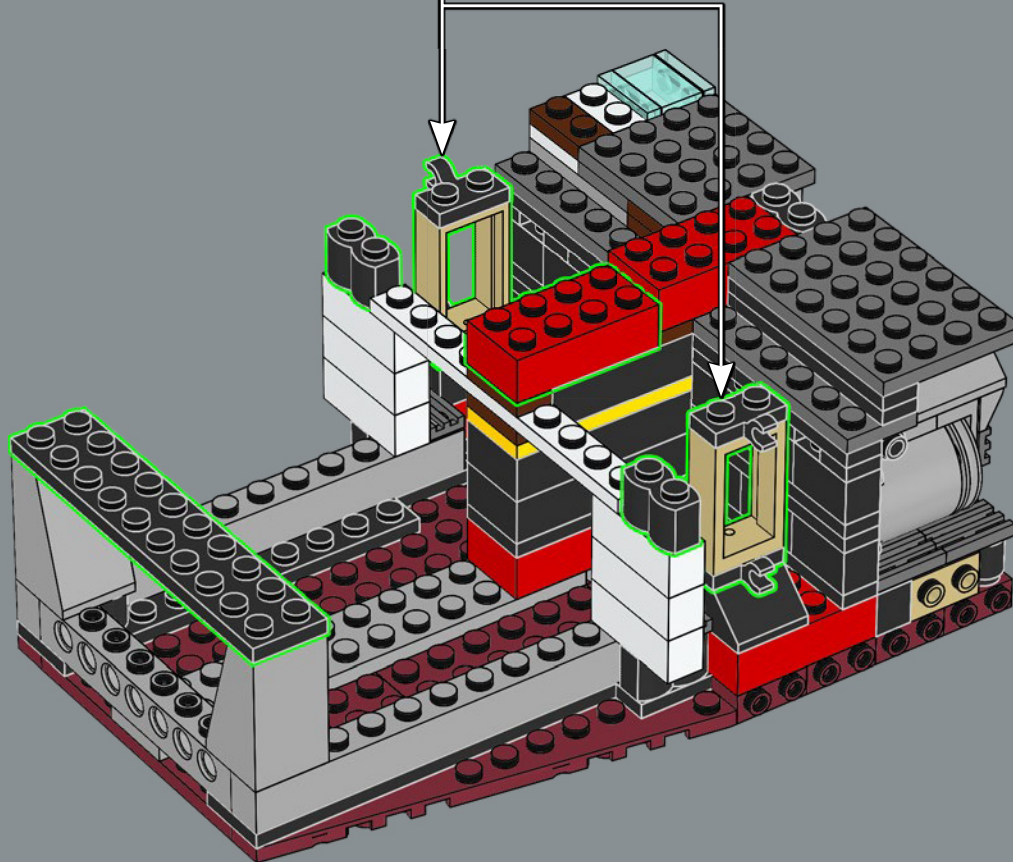
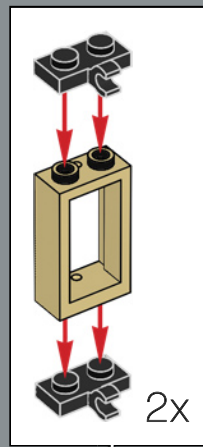

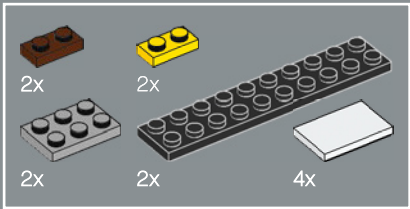

164

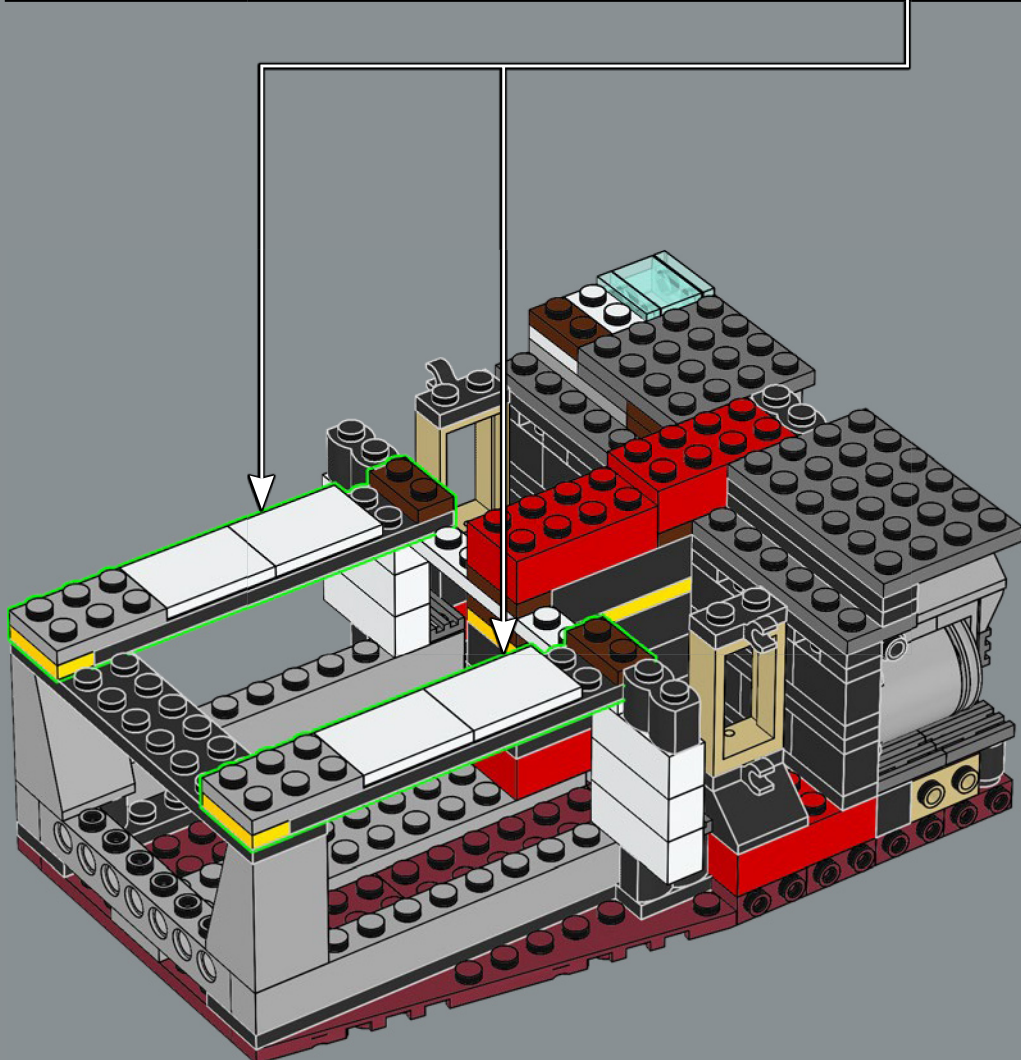
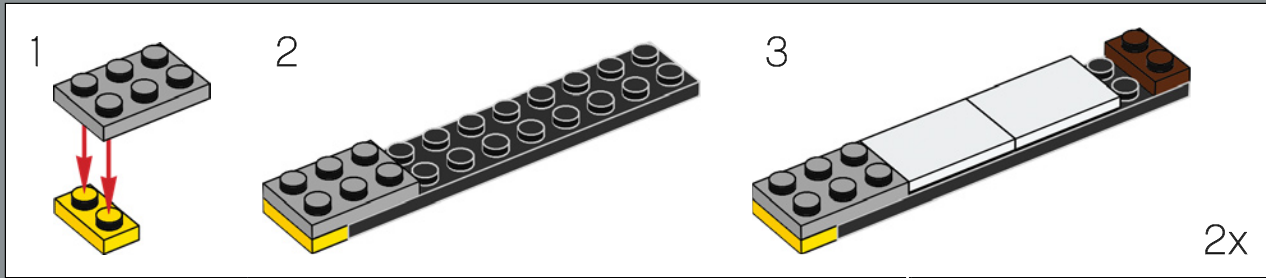

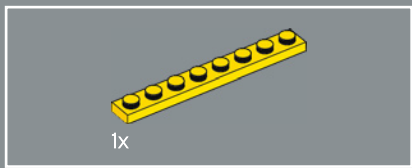

166

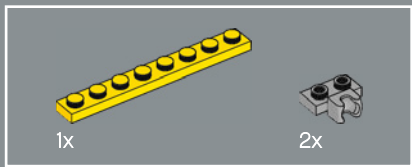
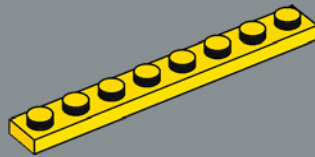

167

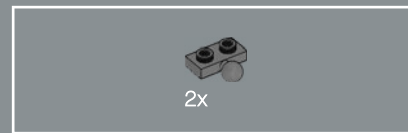
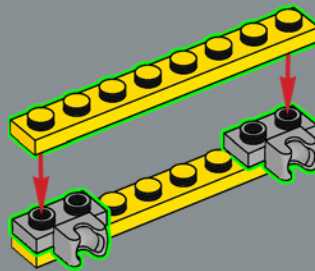

168

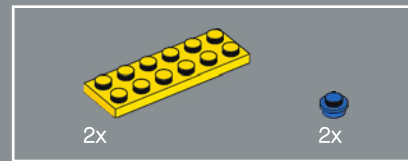
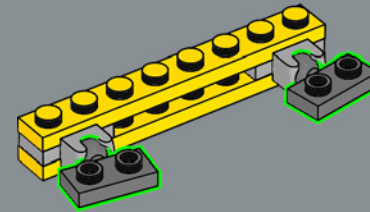

169

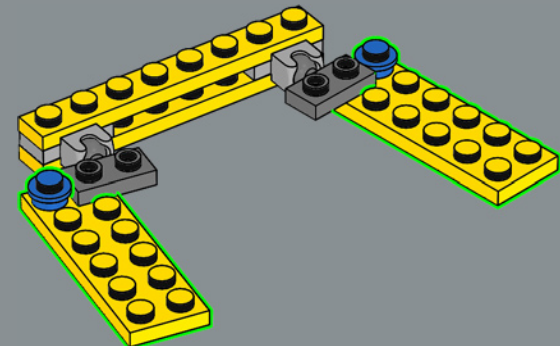

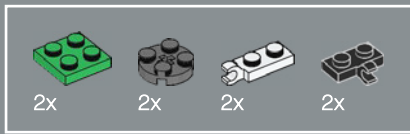

170

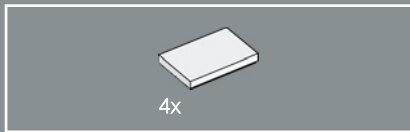
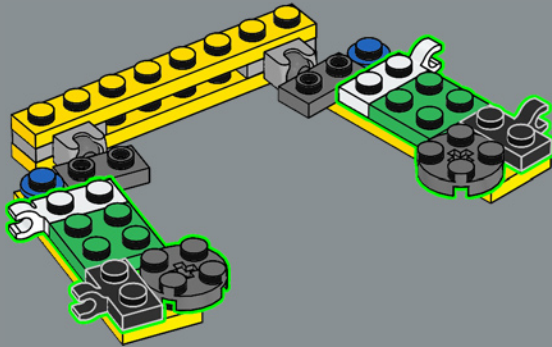

171

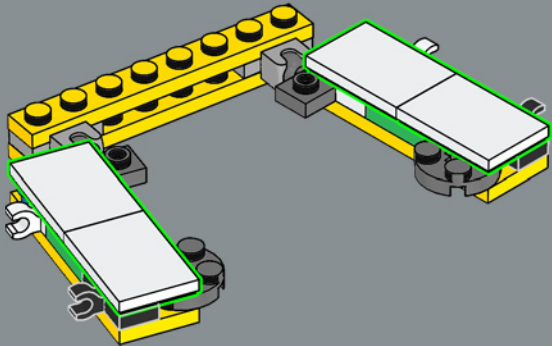

172

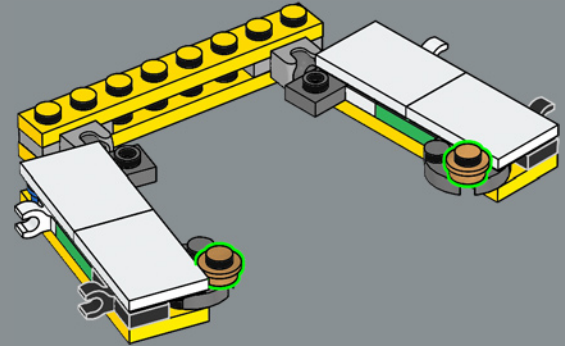

173

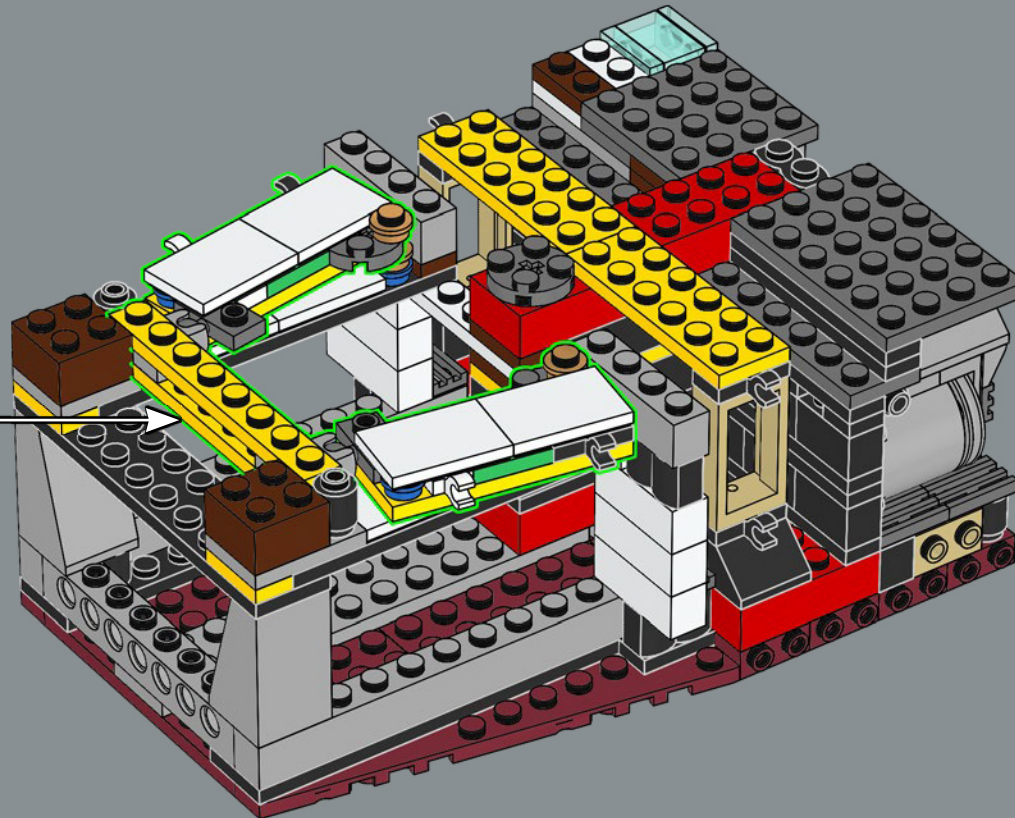

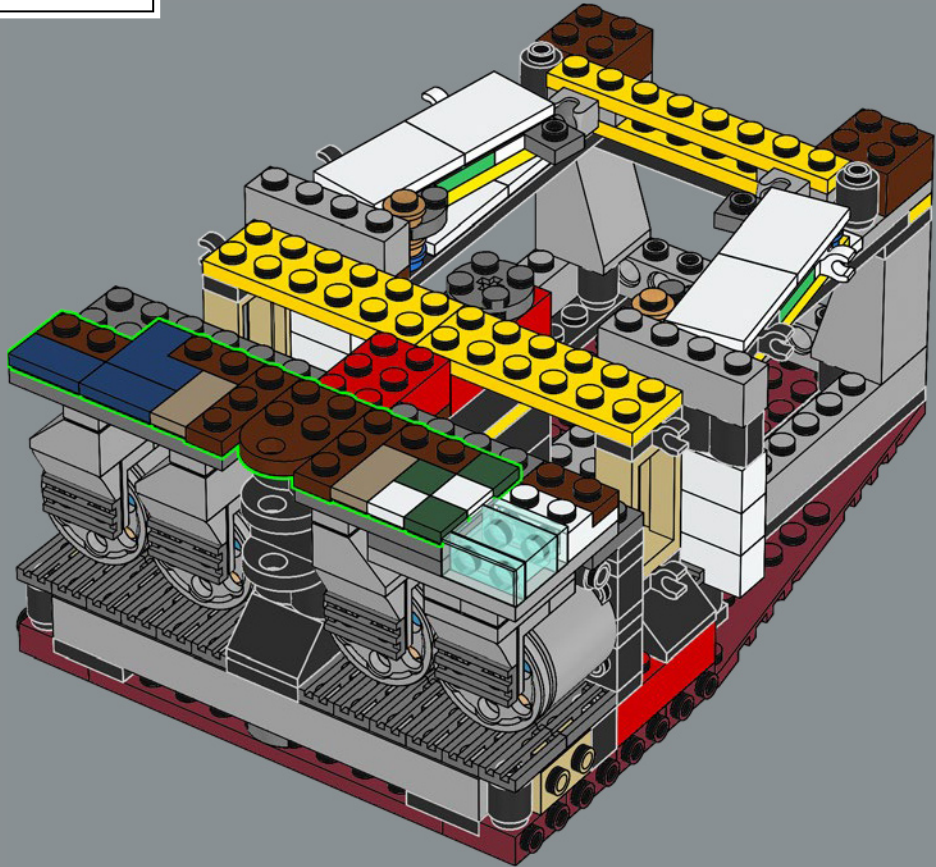
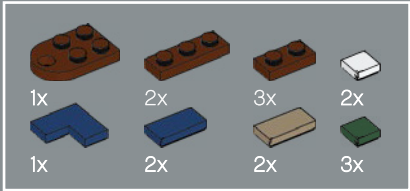
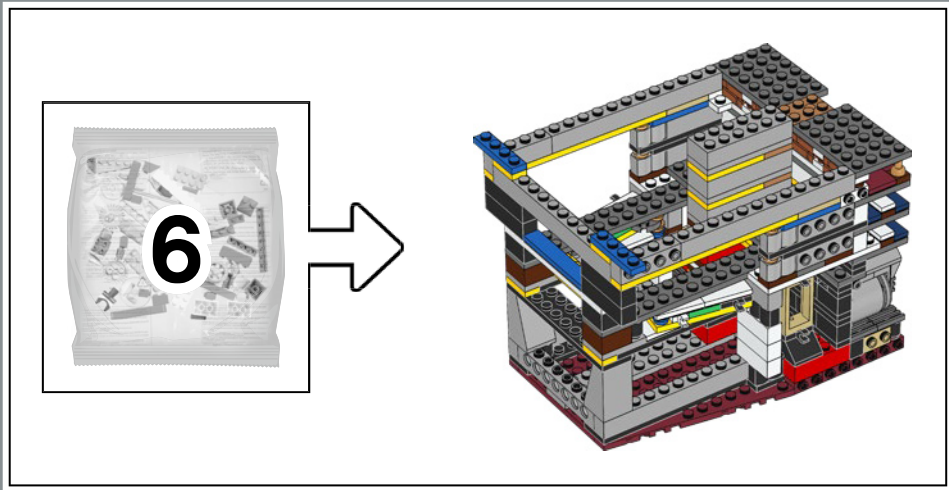

174

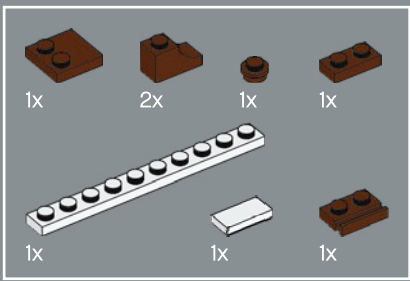

175

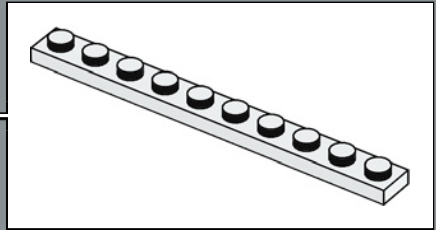
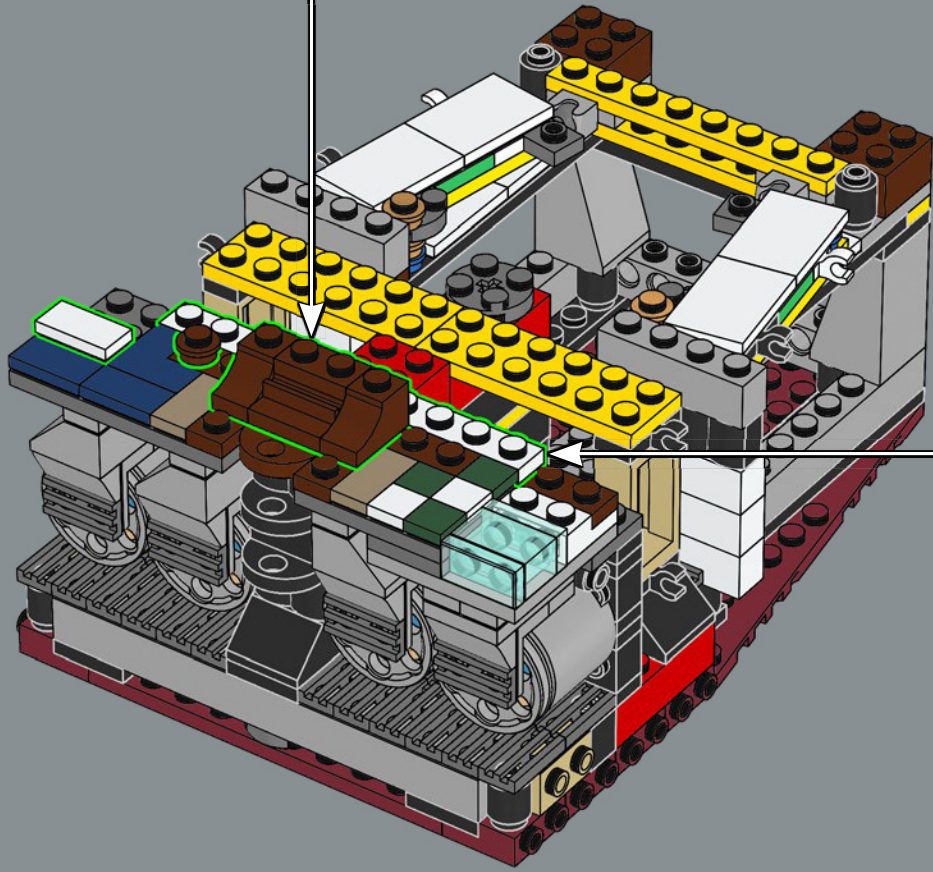
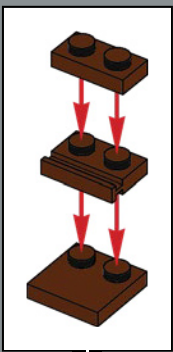

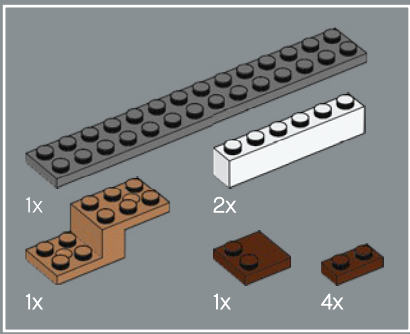

177

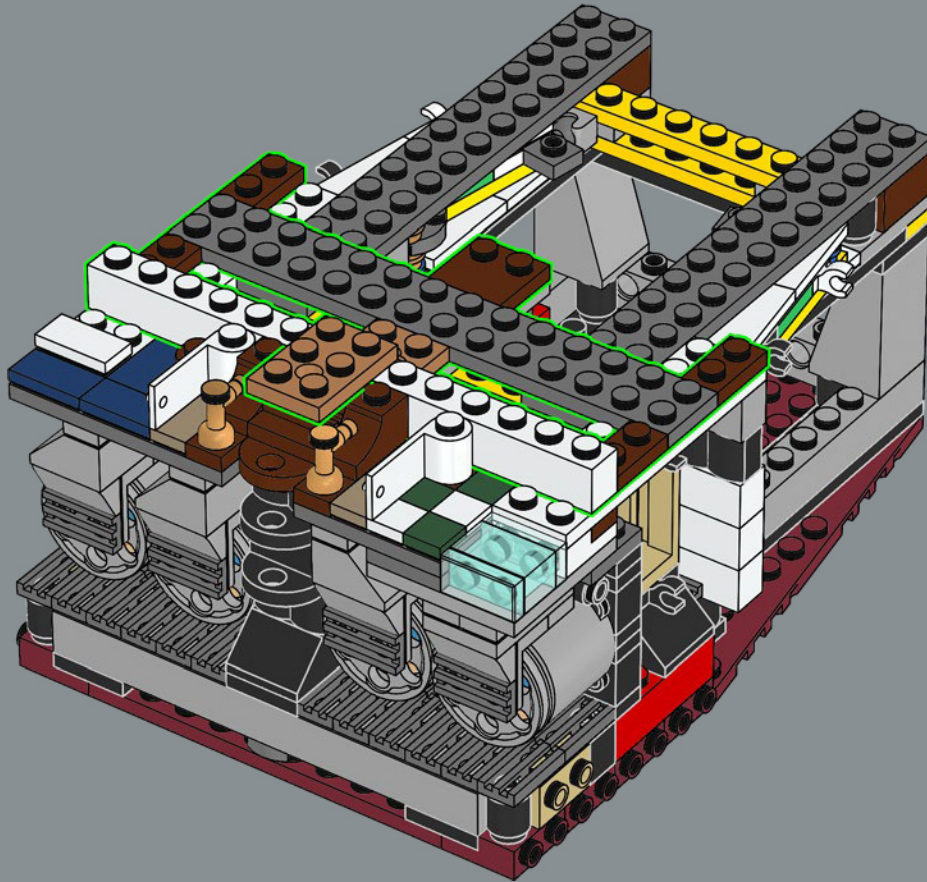

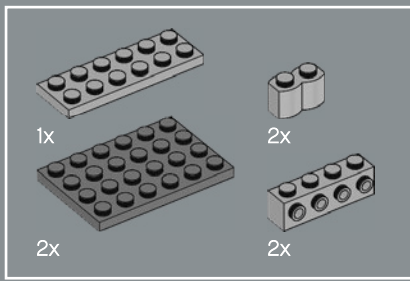

178

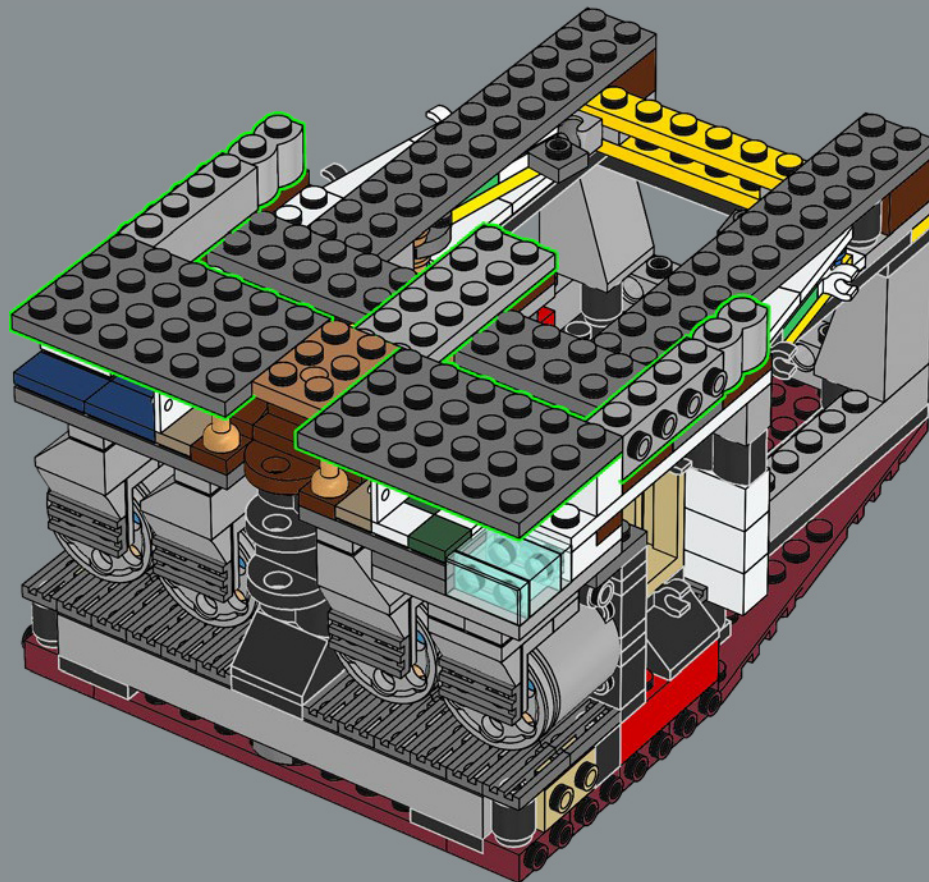

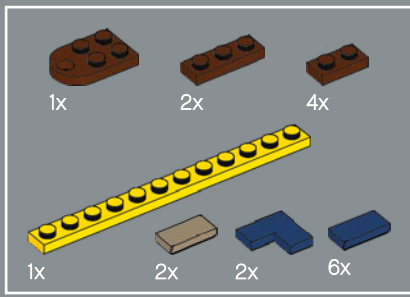

179

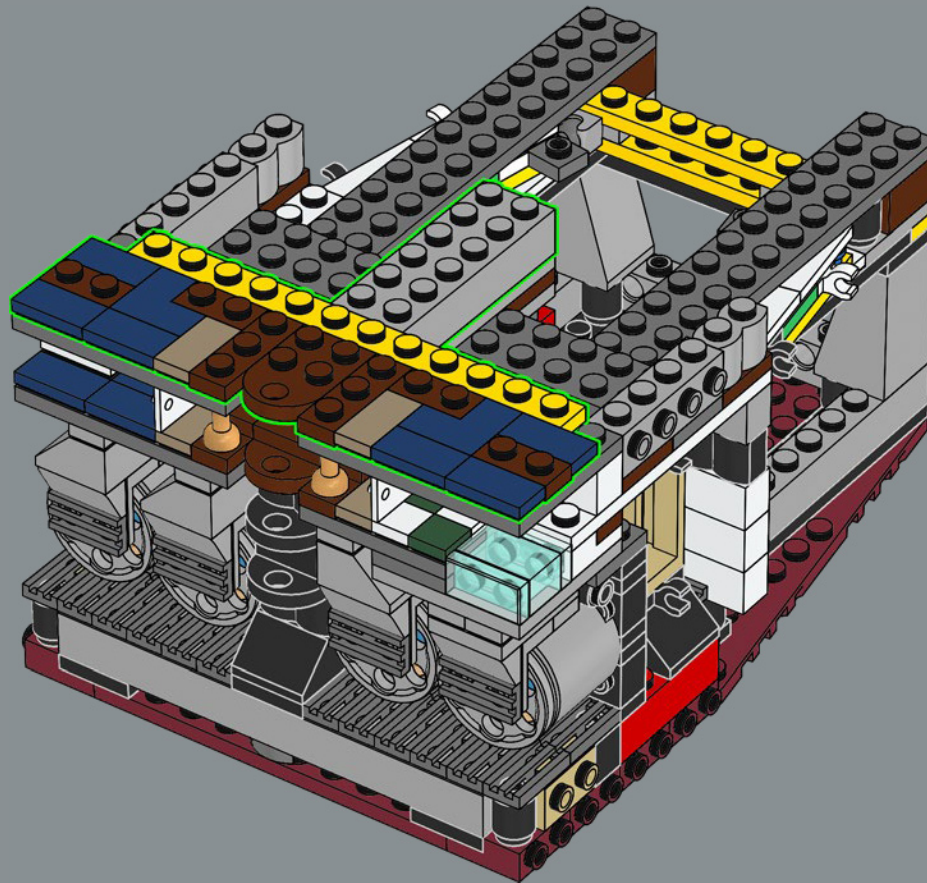

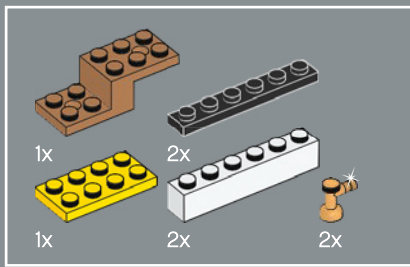

181

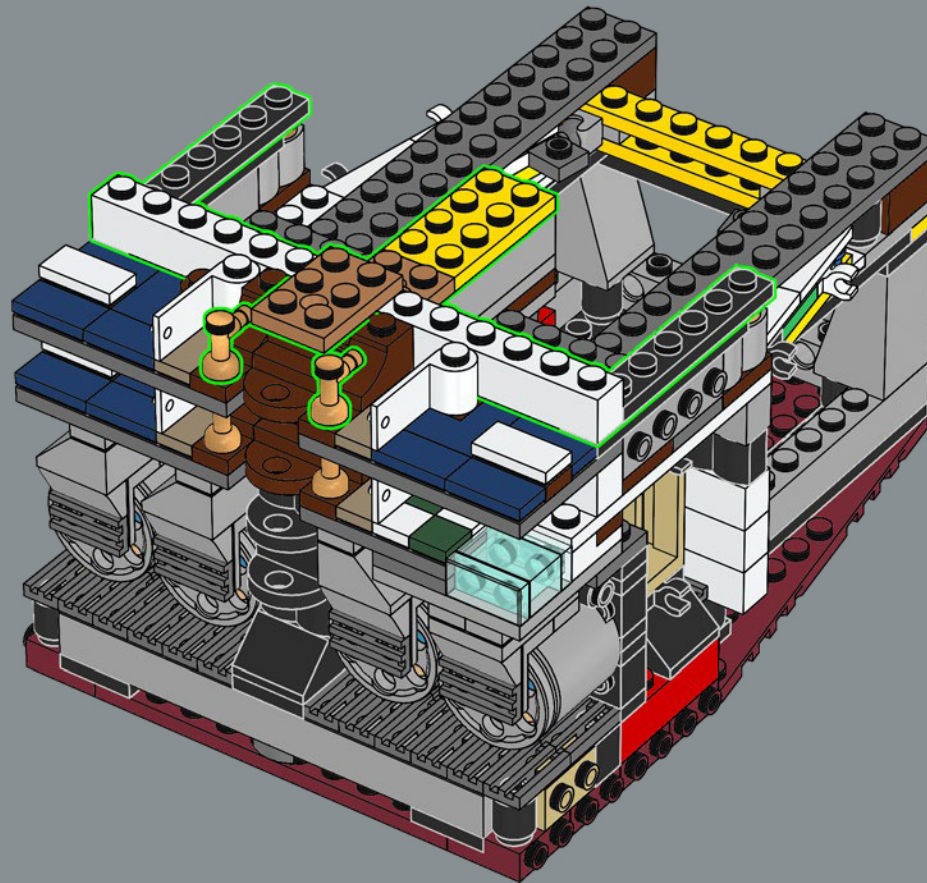

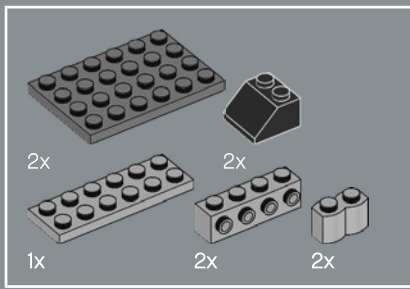

182

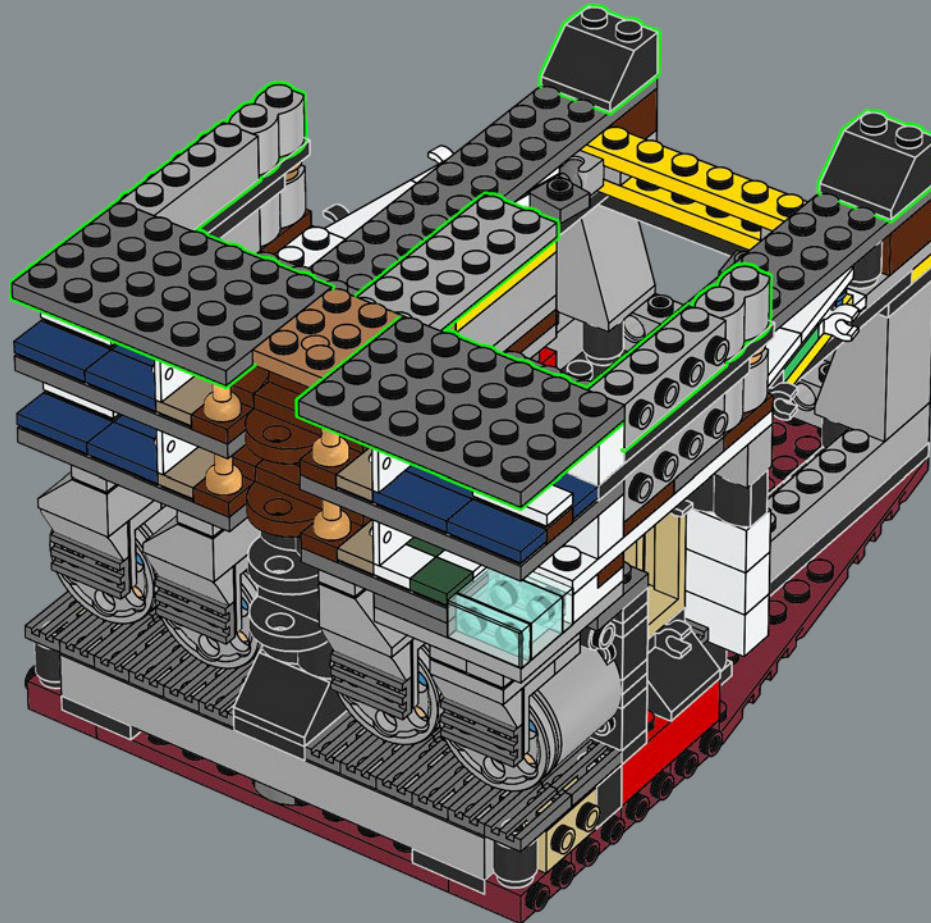

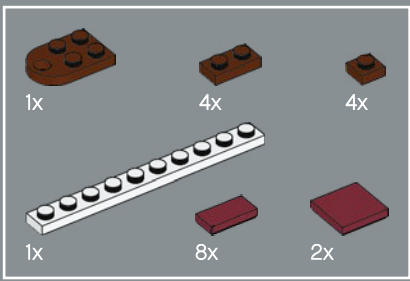

183

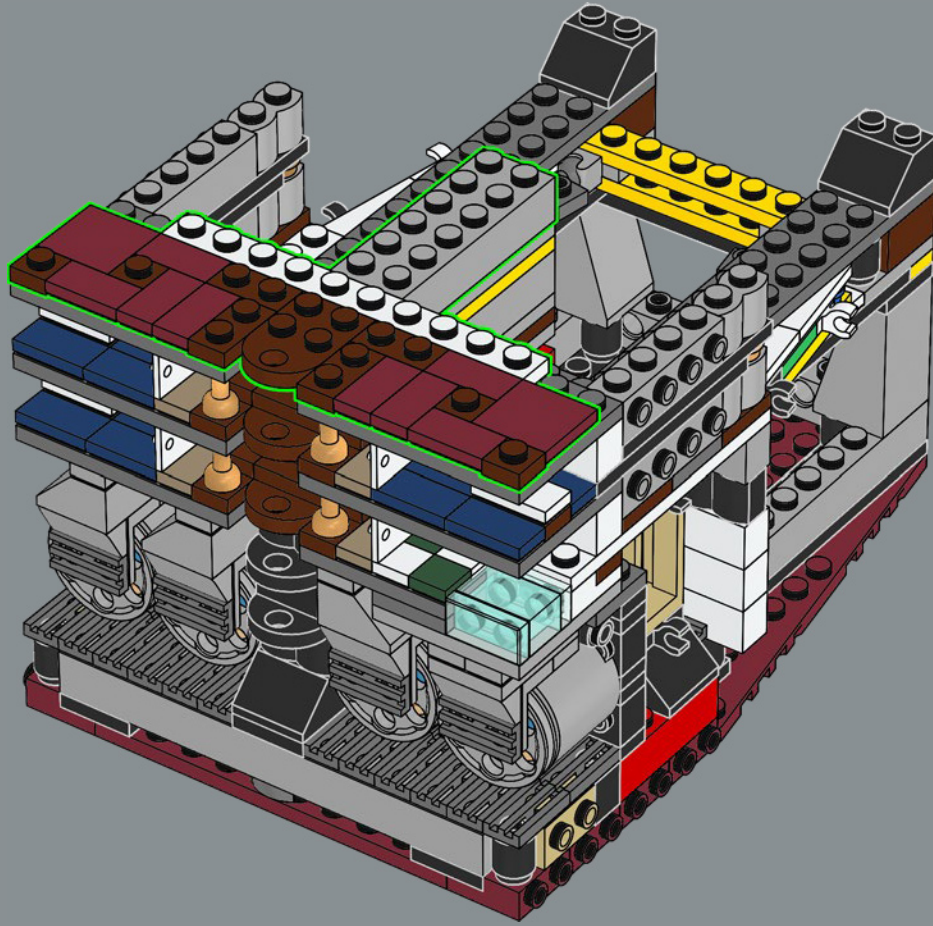

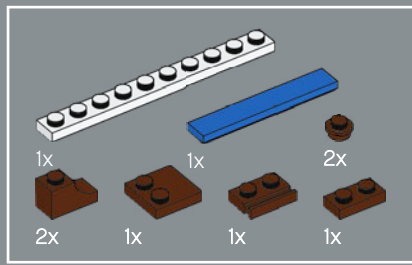

184

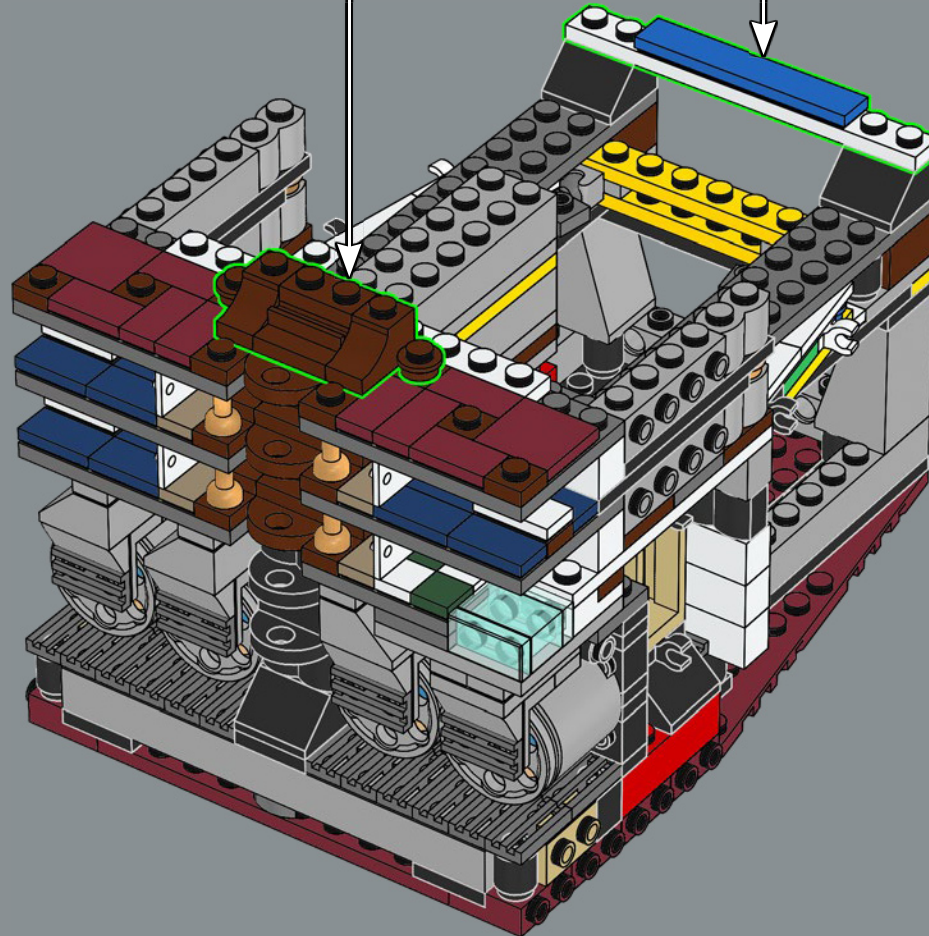
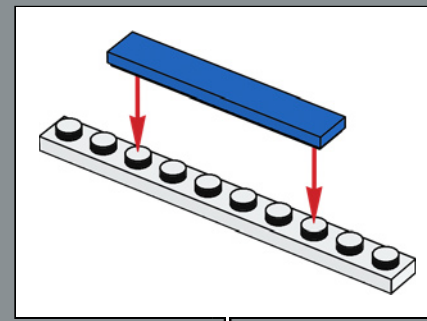
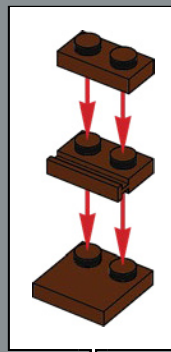

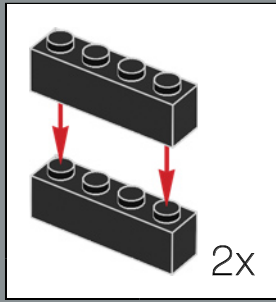
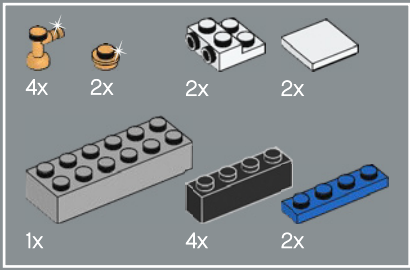

185

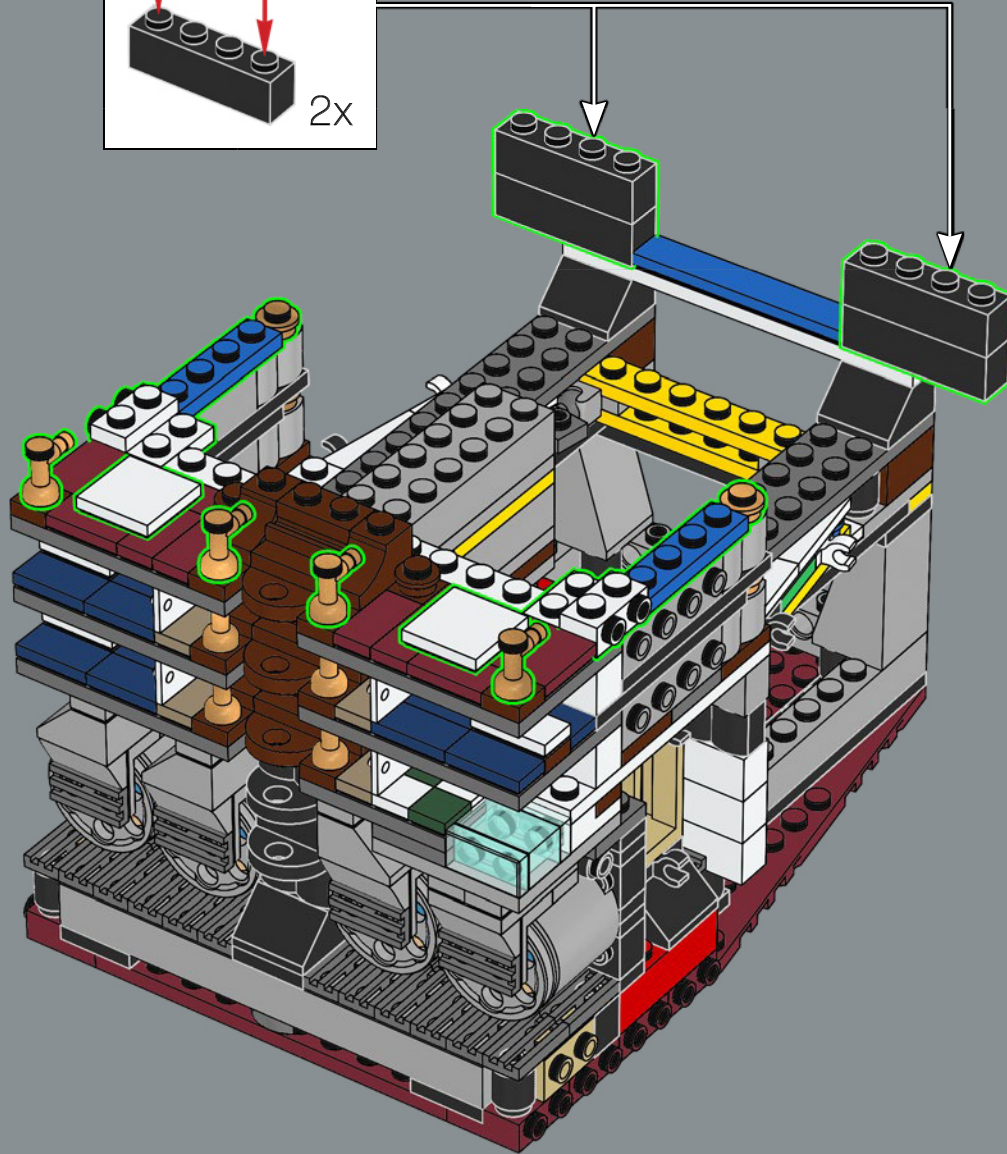

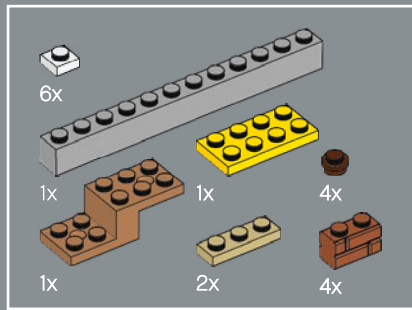

186

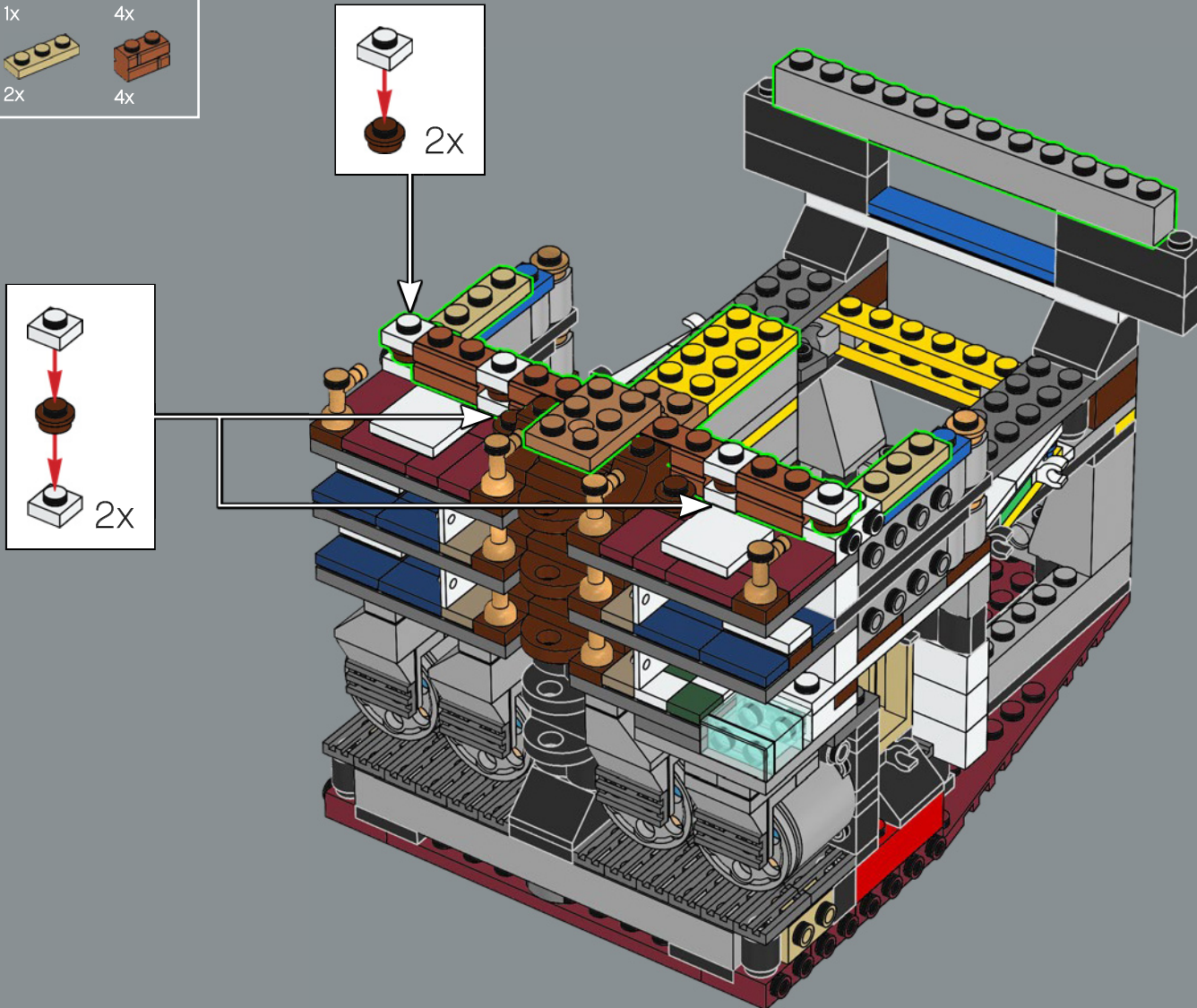

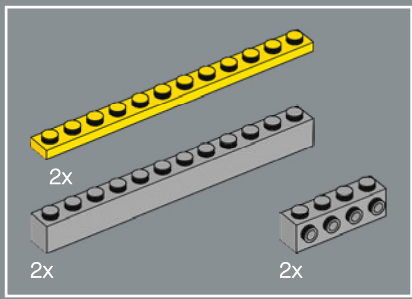

187

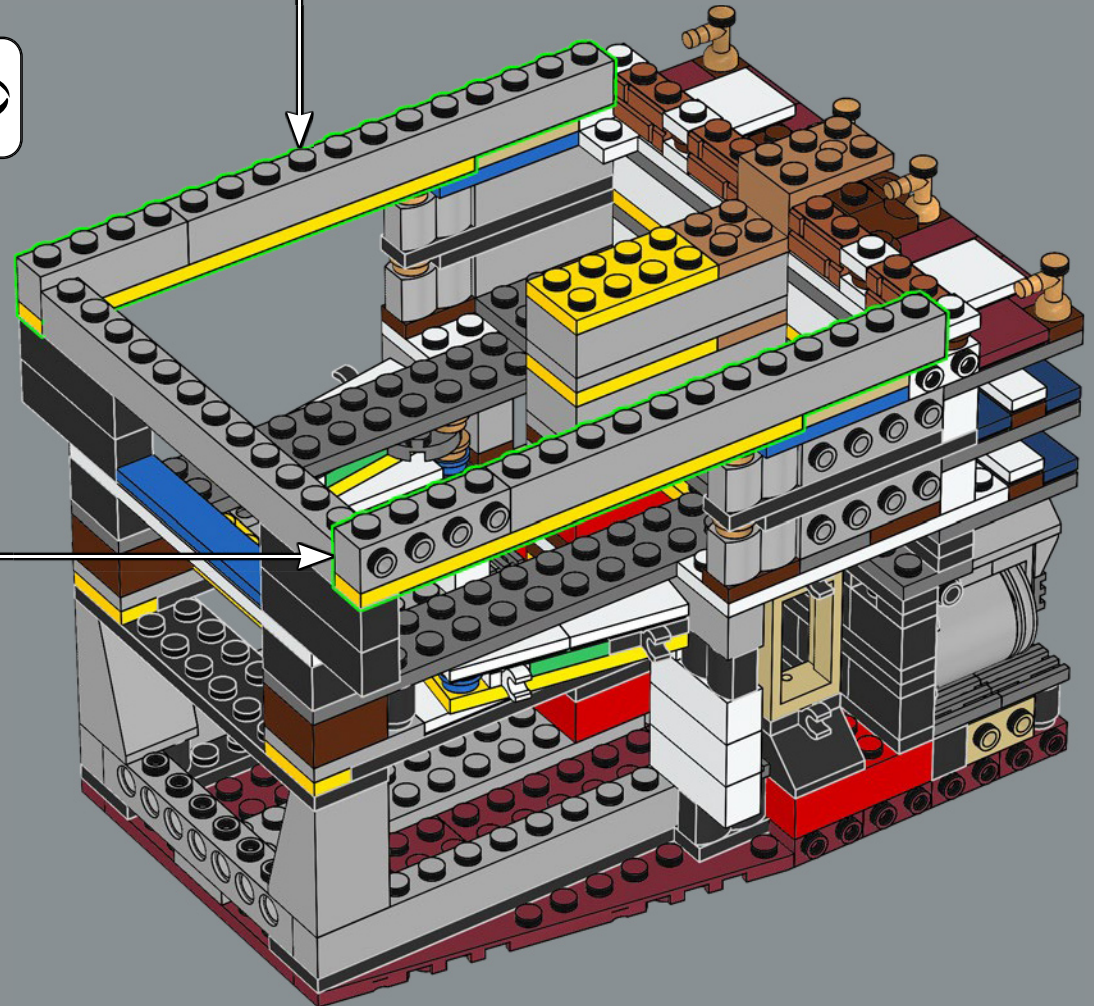
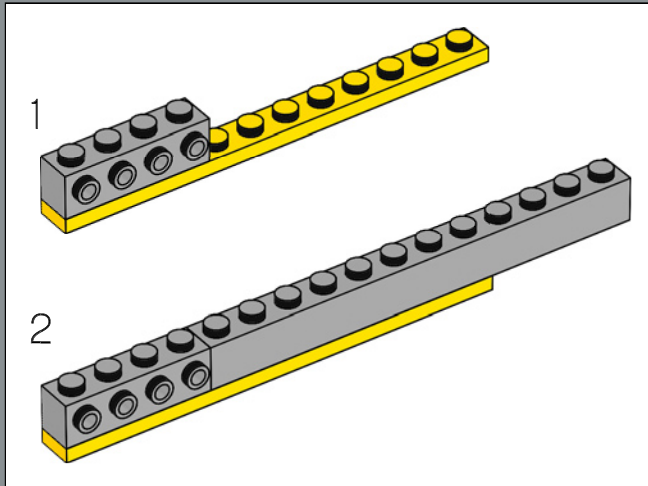
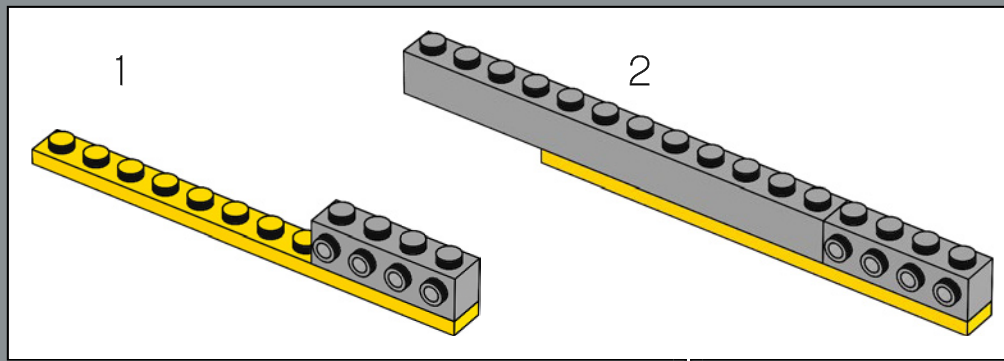

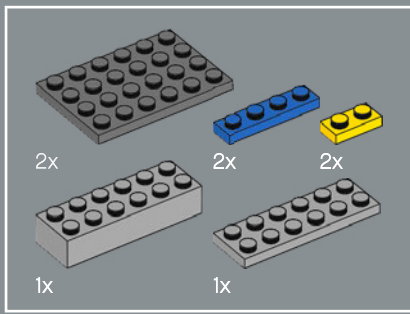

188

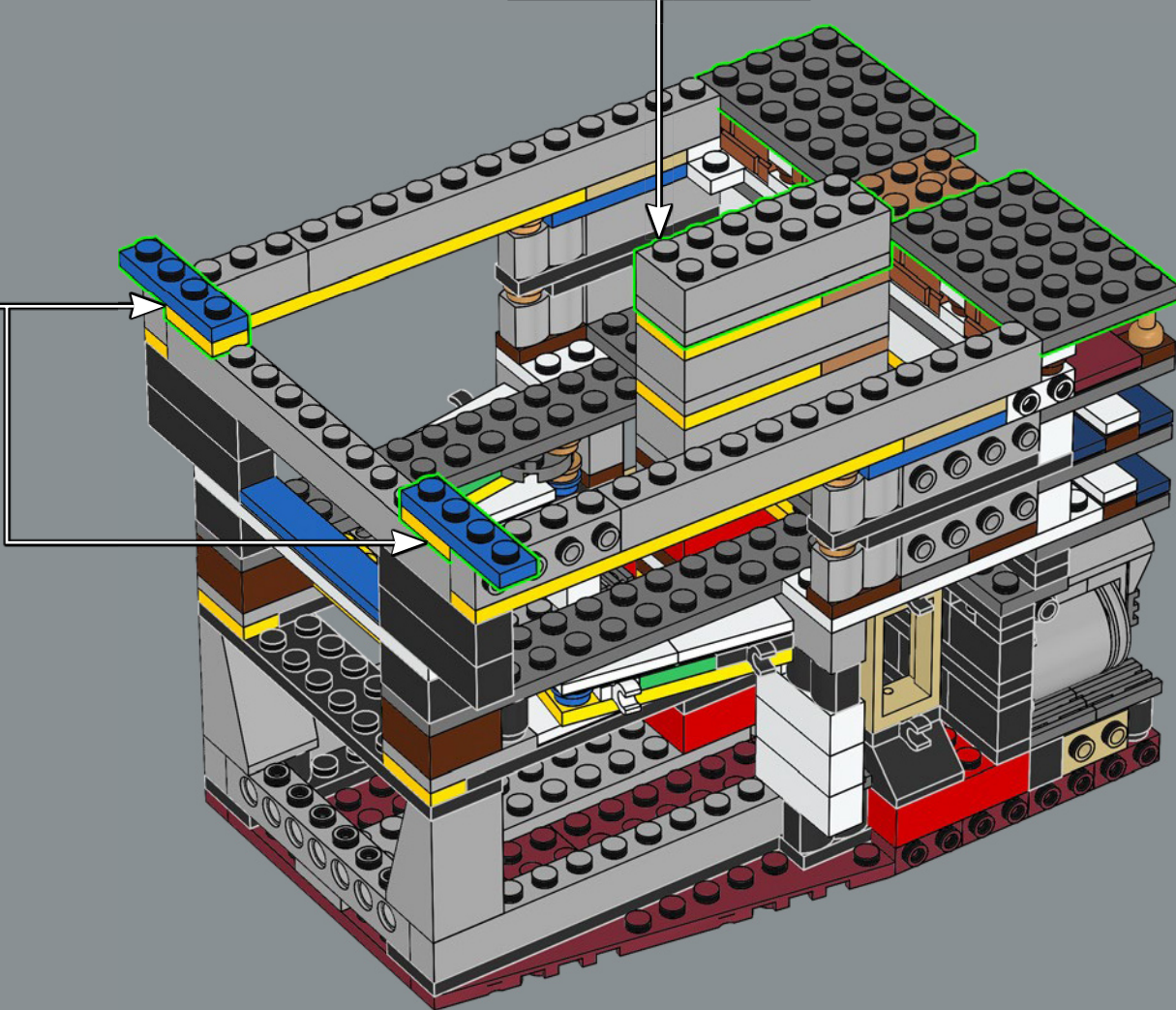
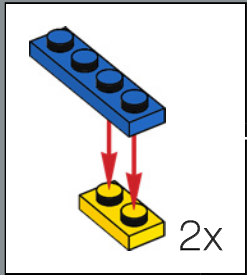
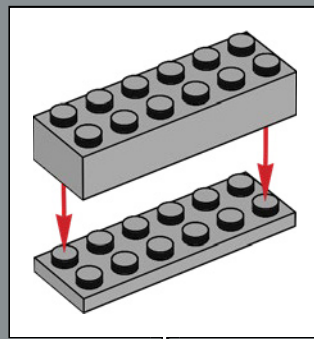

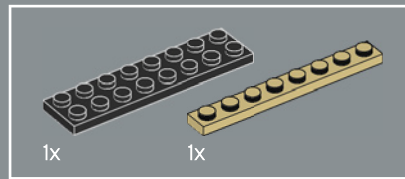
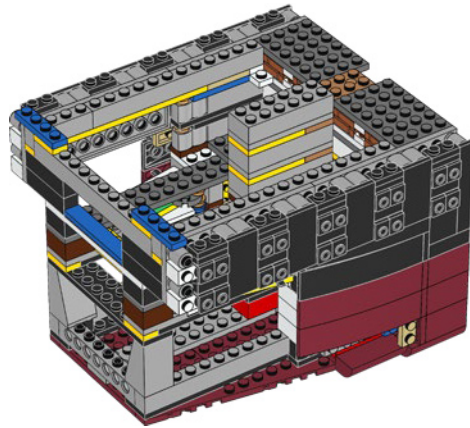
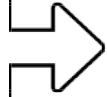

190

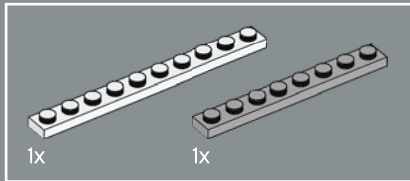
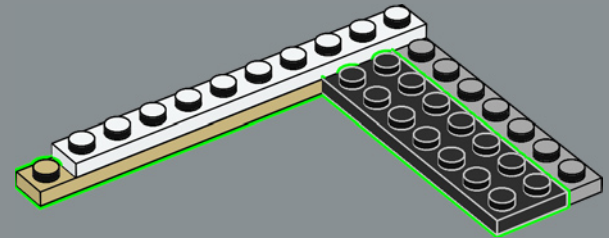

189

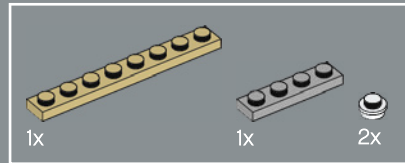
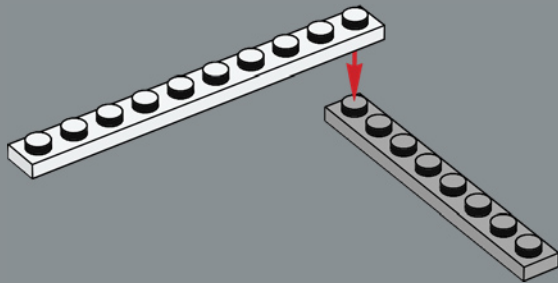

191

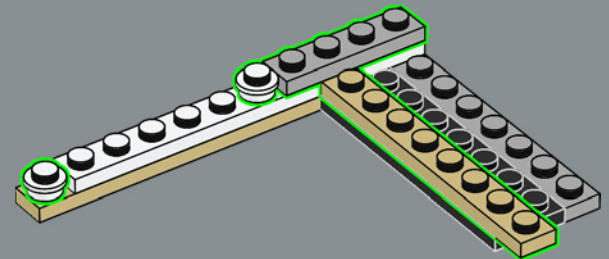

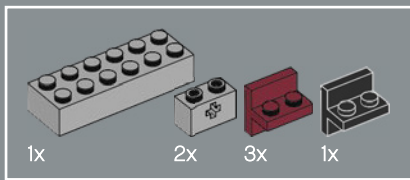

192

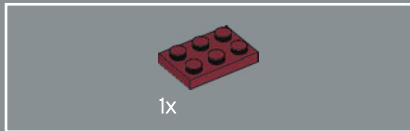
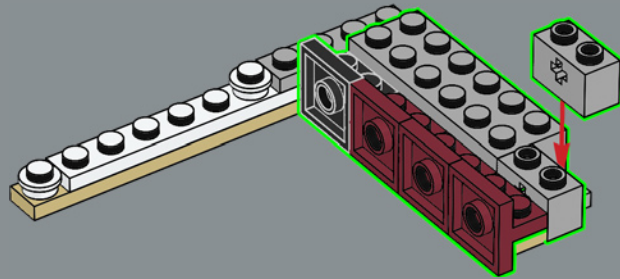

193

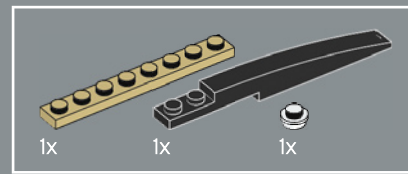
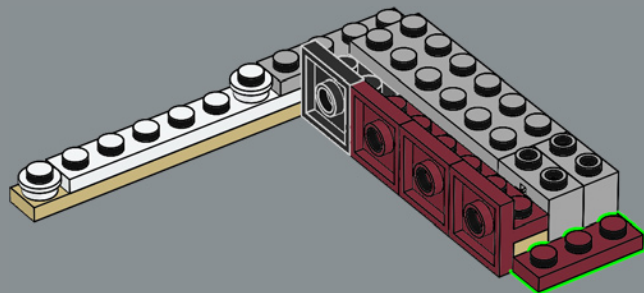

194

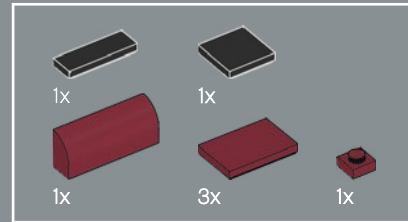
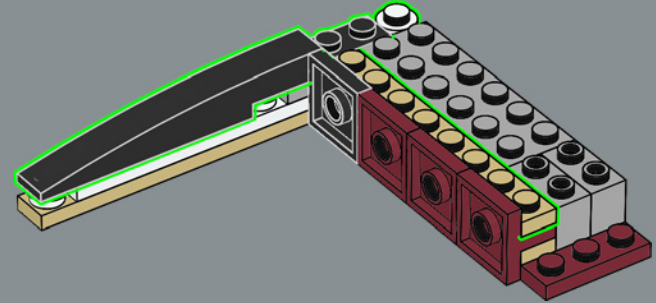

195

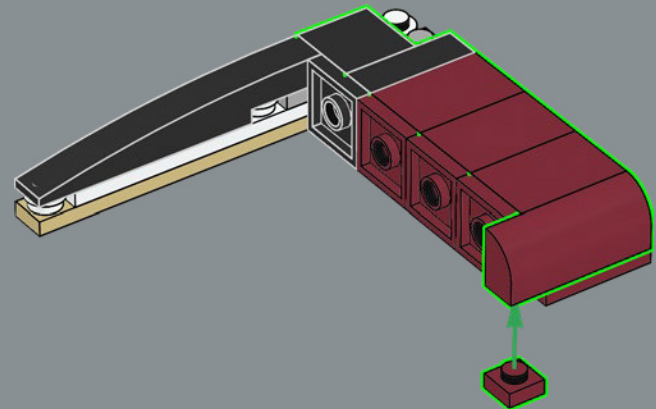

196

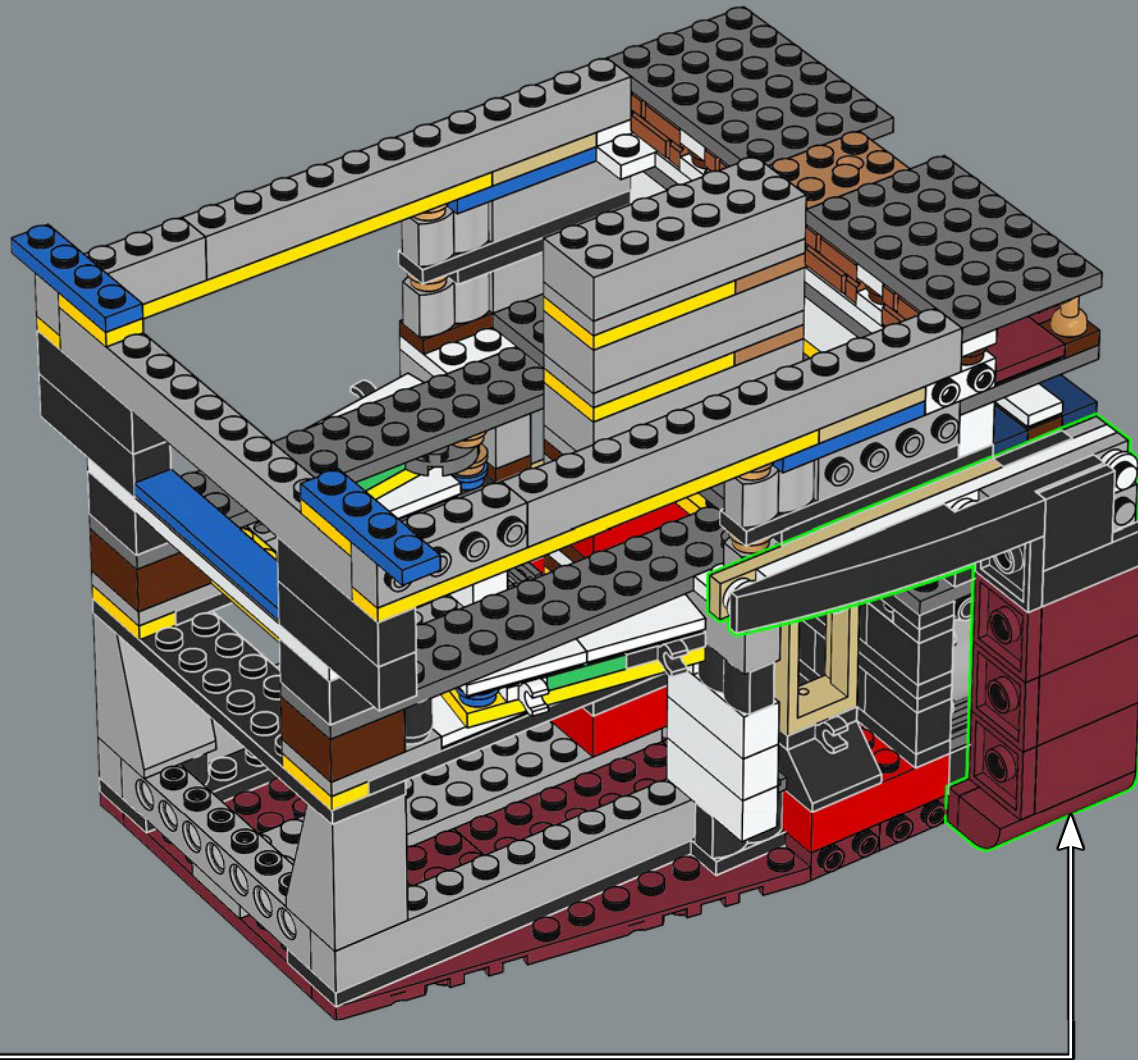

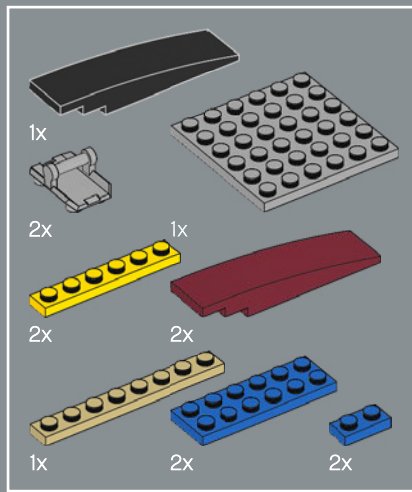

197

1

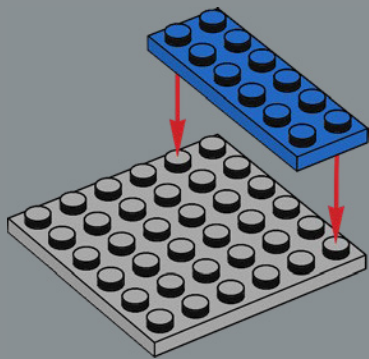

2

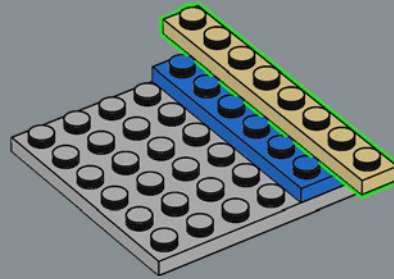

3

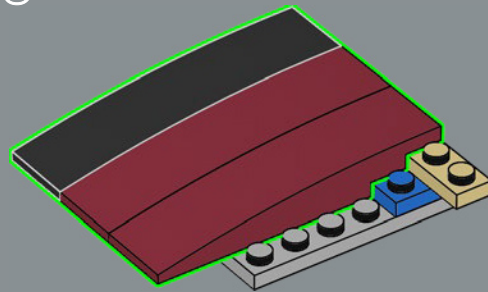

4

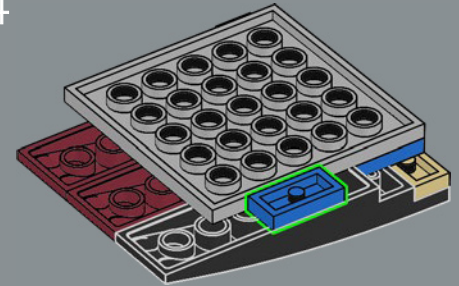

5

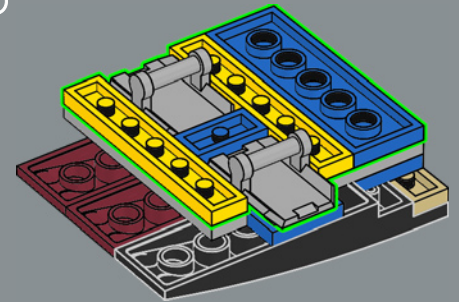

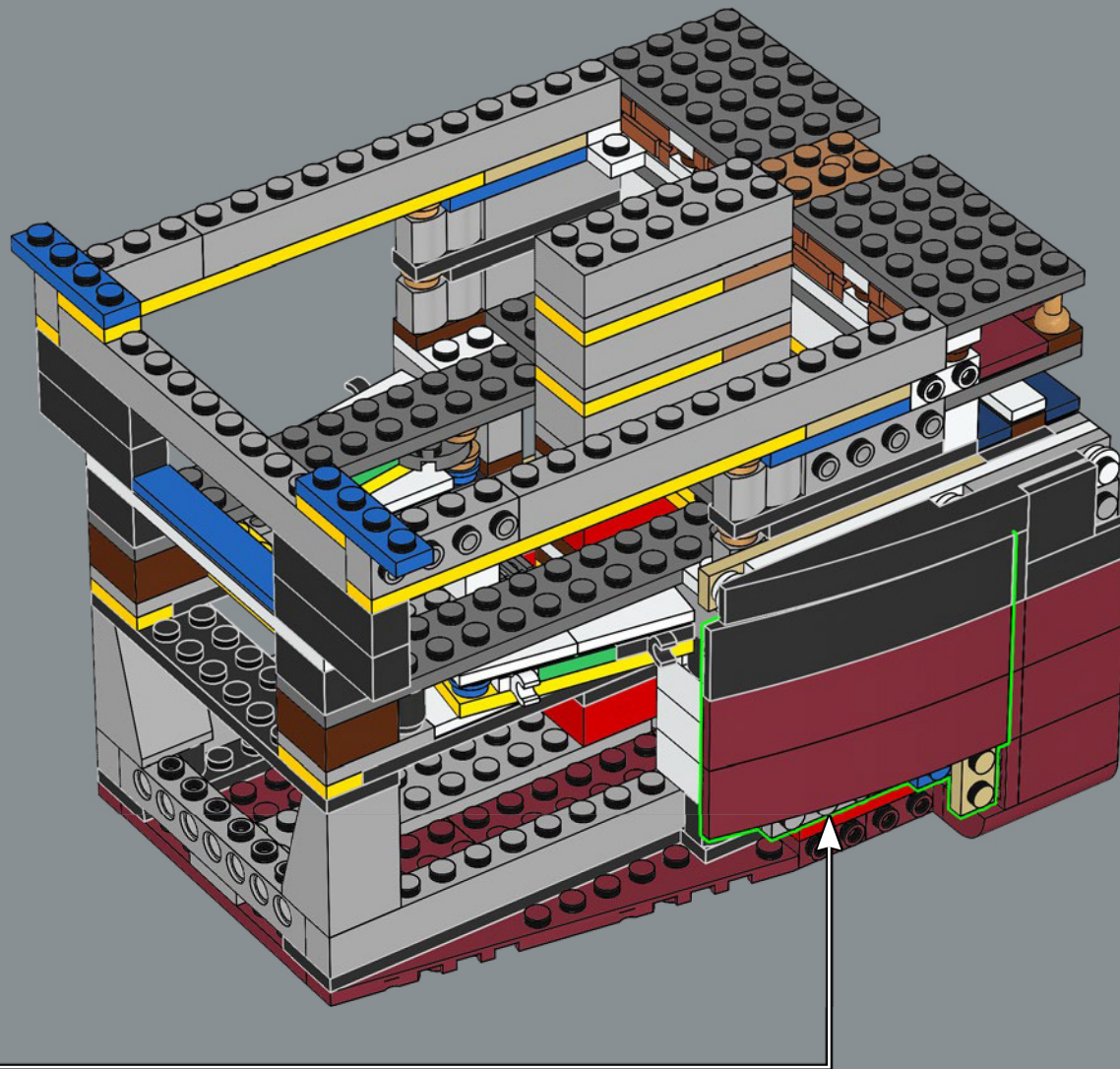

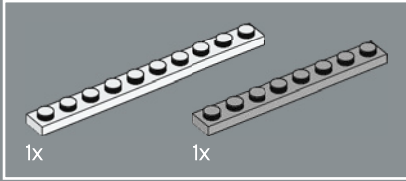
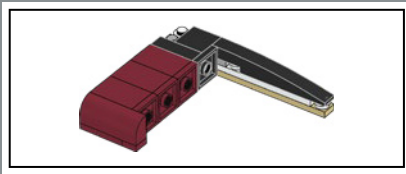

198

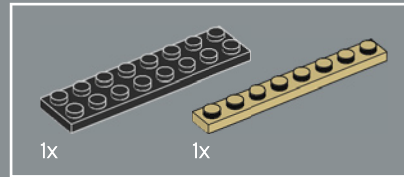
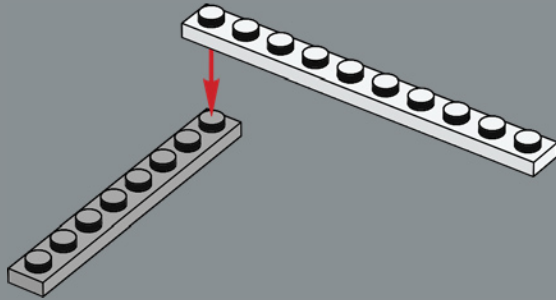

199

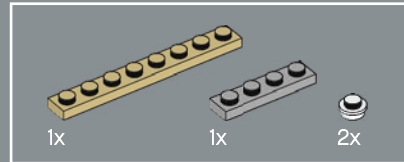
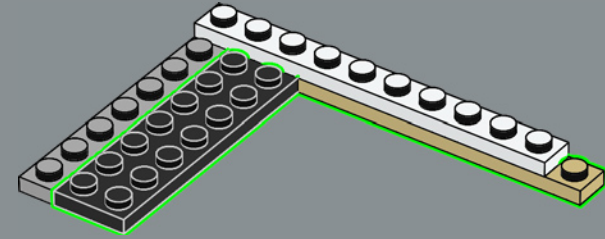

200

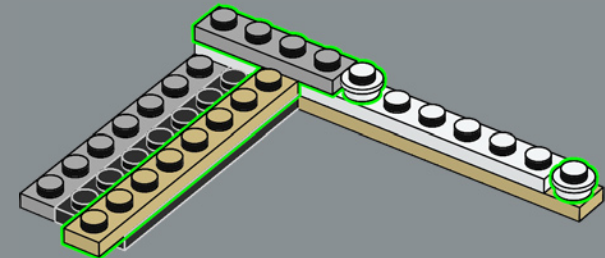

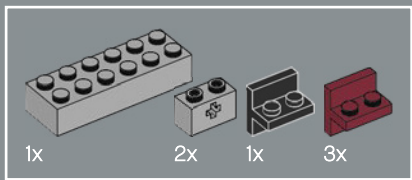

201

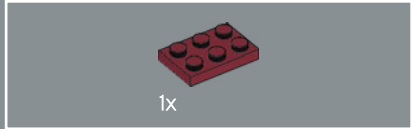
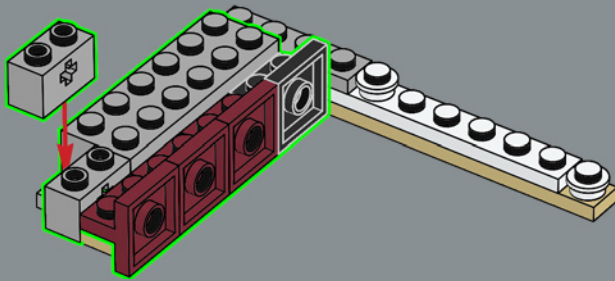

202

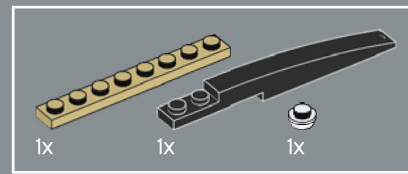
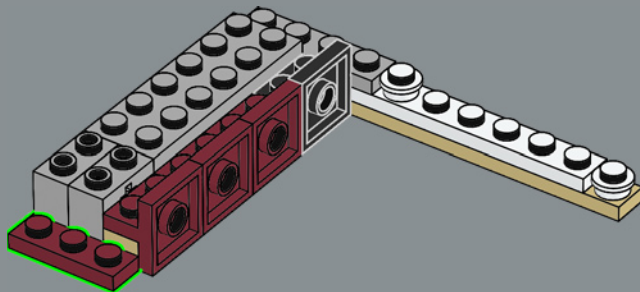

203

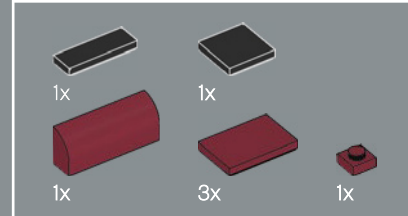
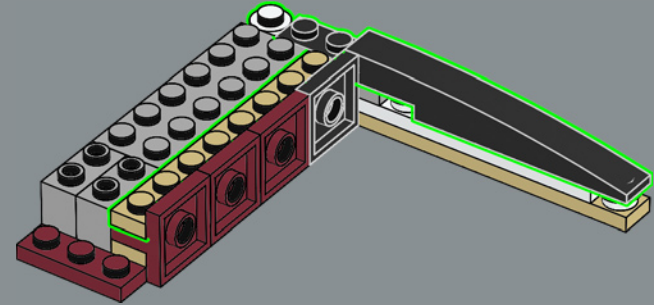

204

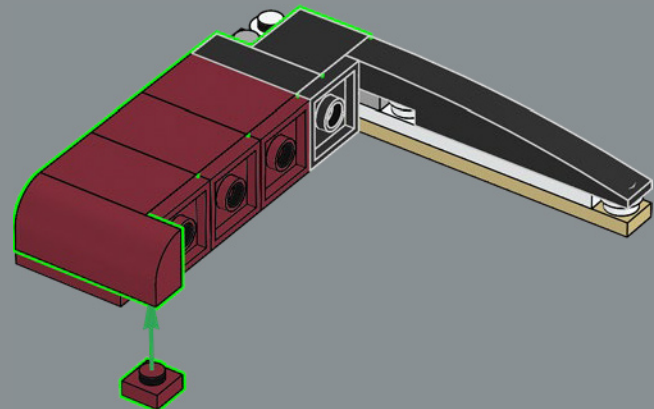

205

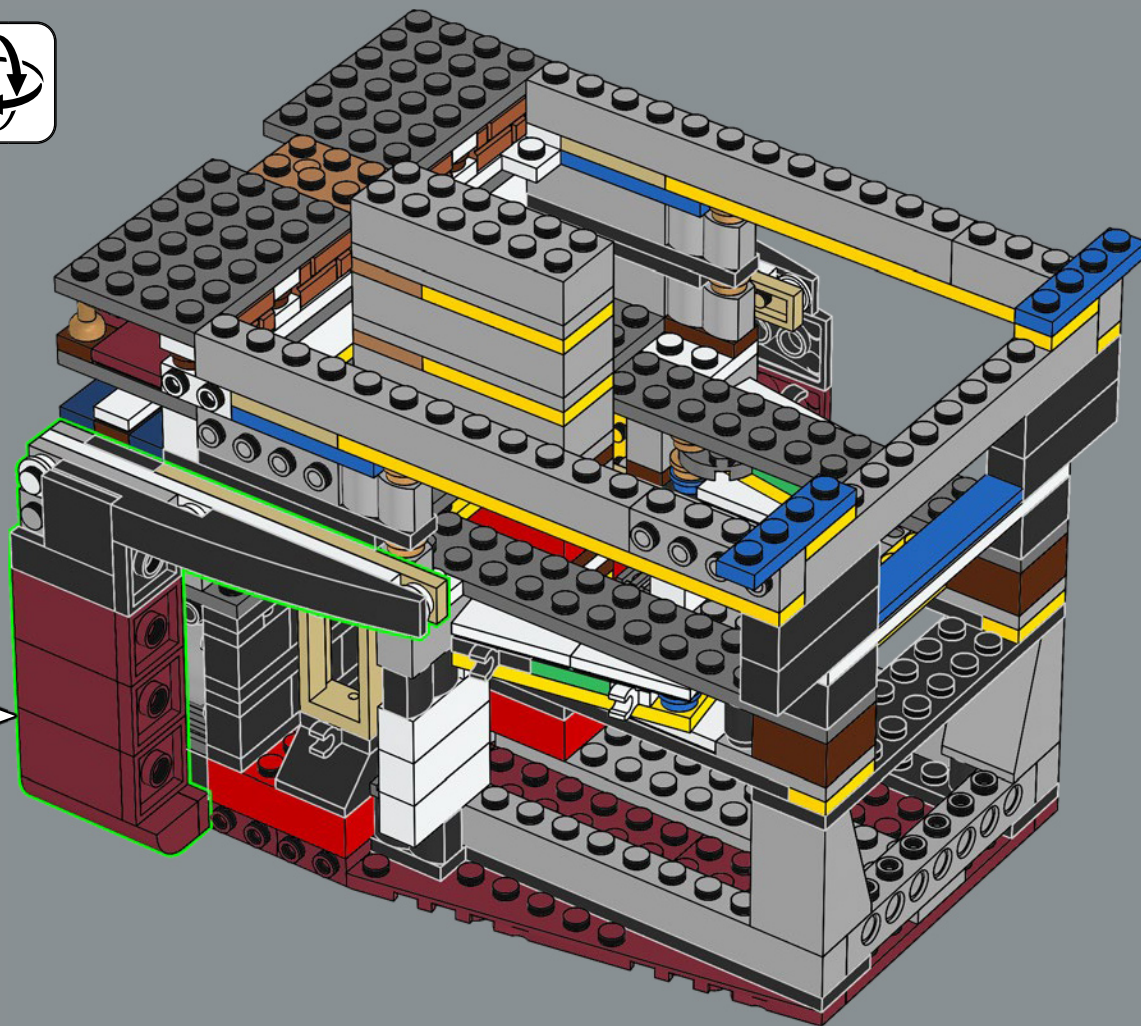

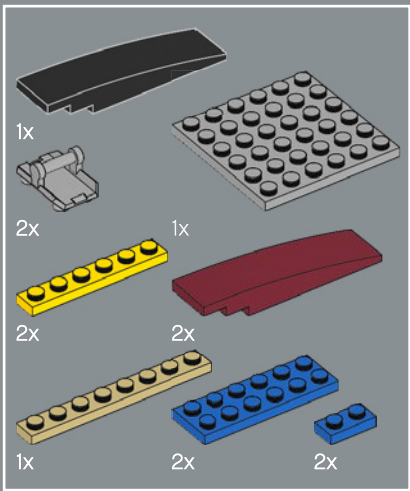

206

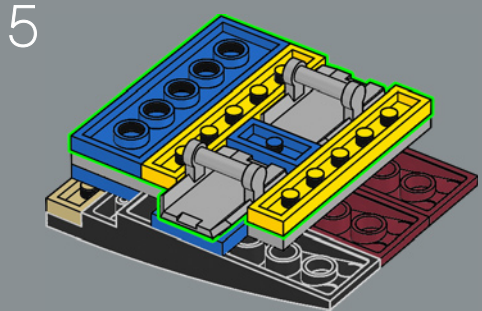
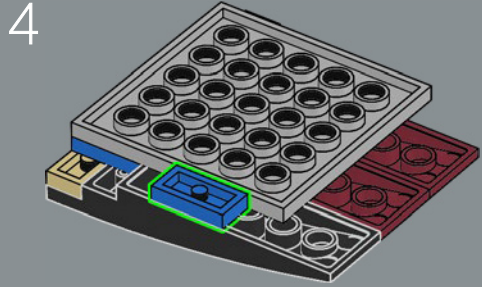
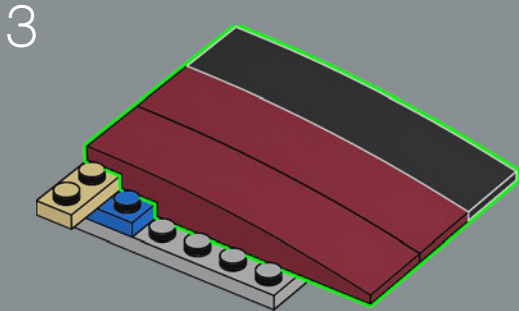
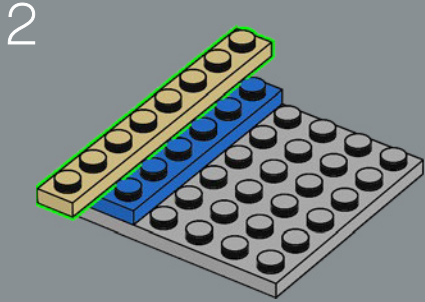
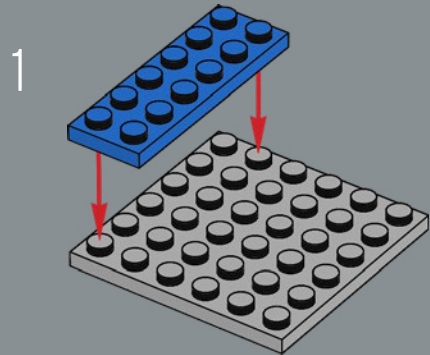

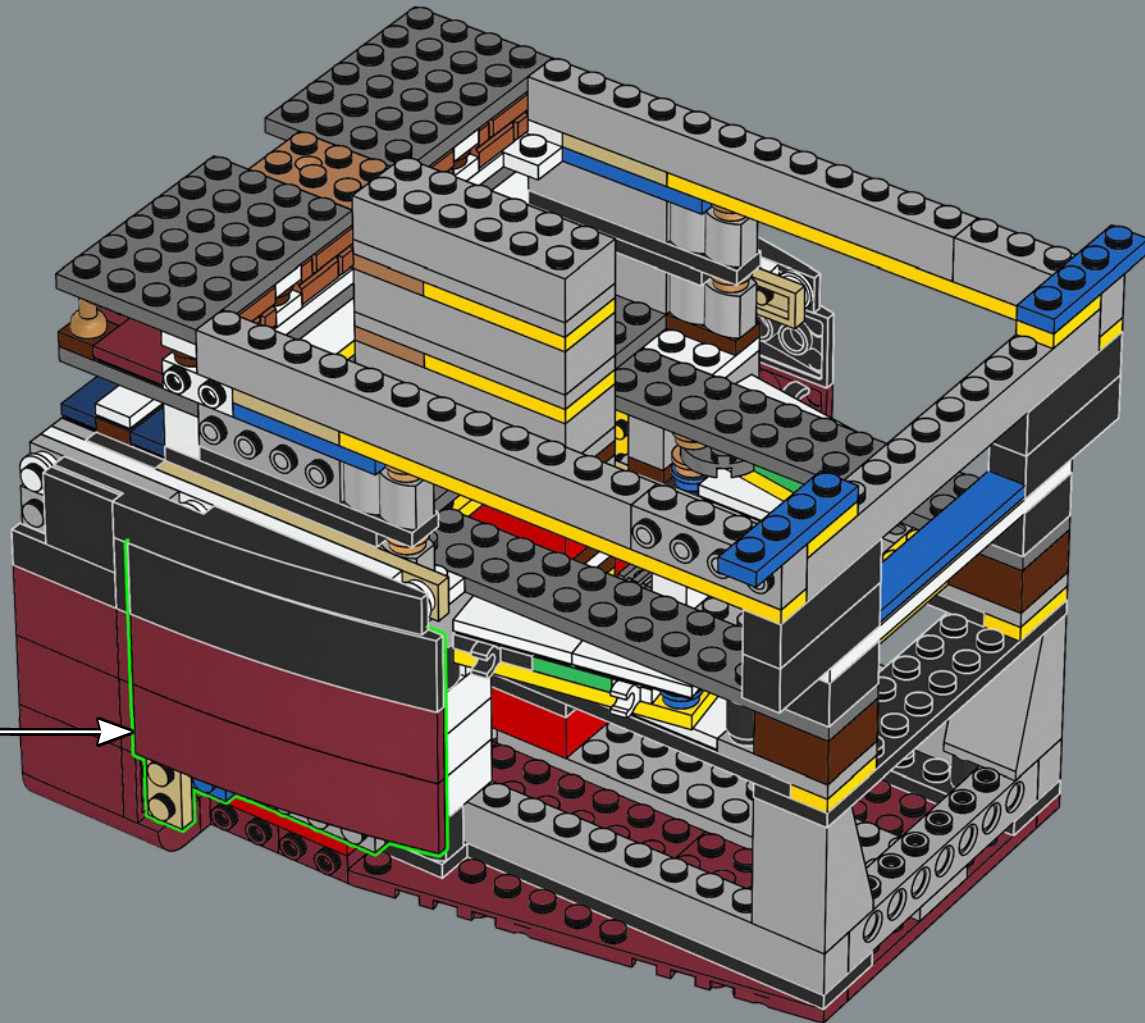

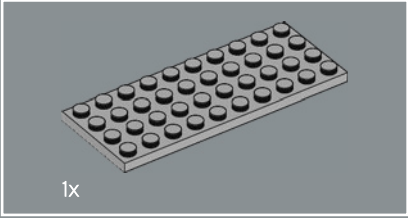
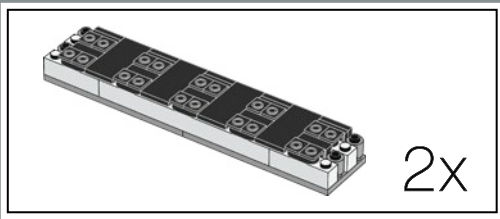

207

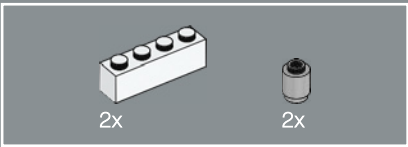
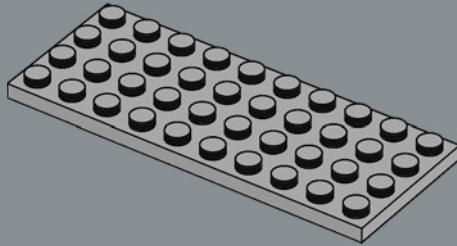

208

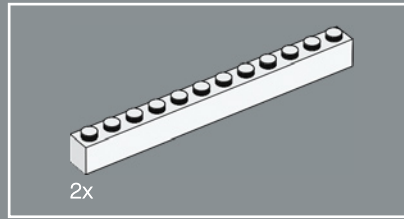
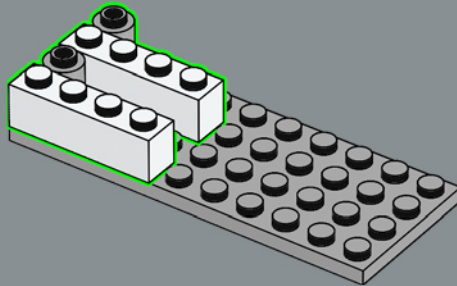

209

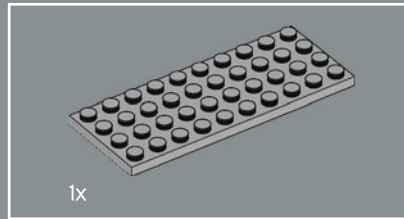
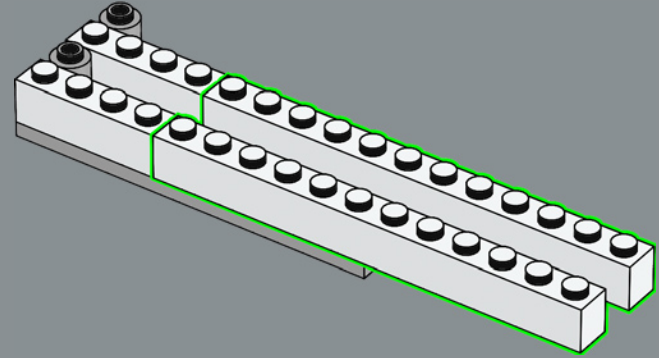

210

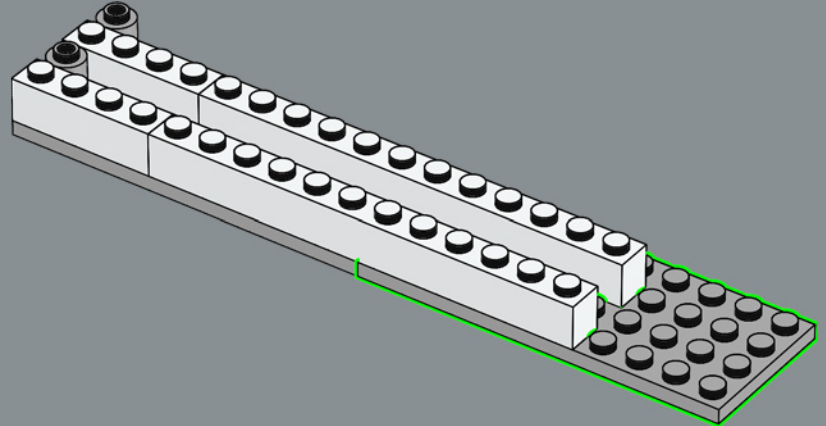

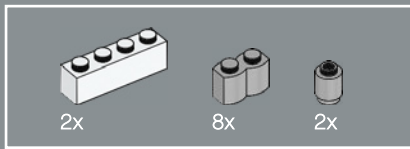

211

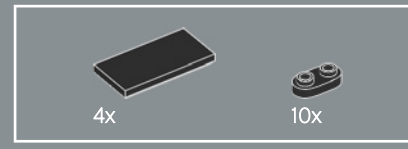
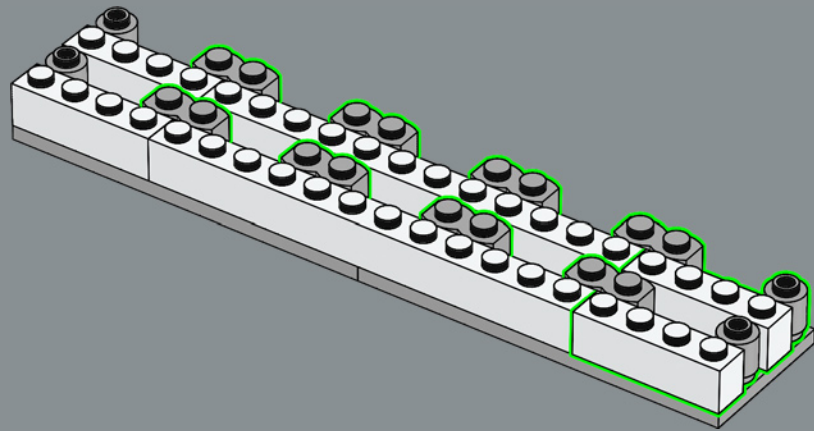

212

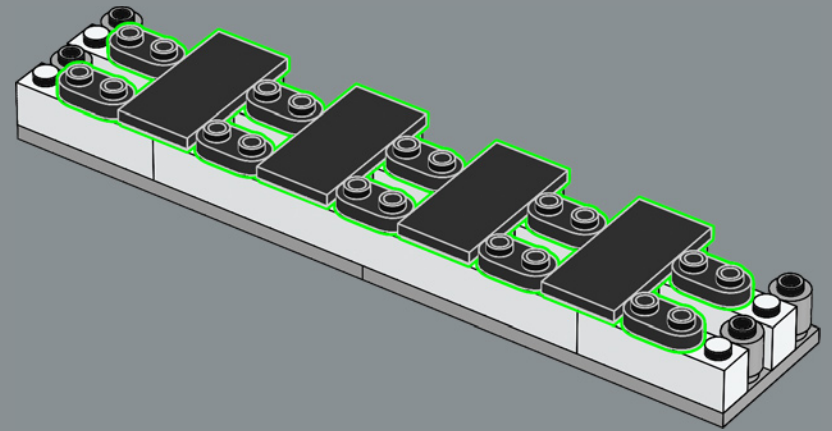

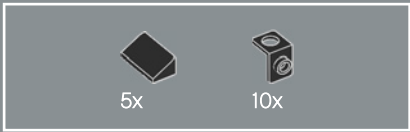

213

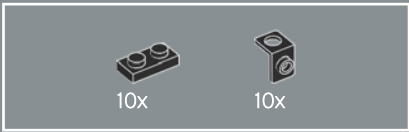
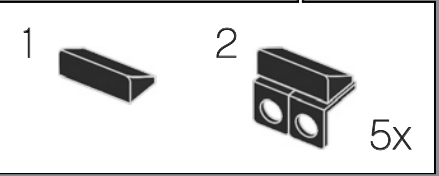
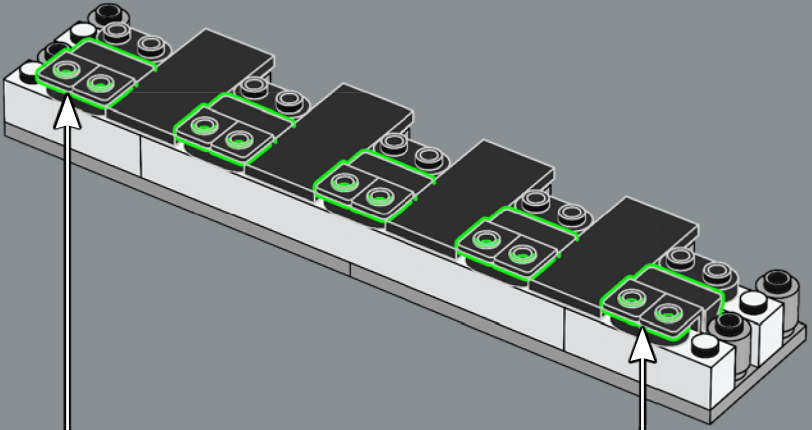

214

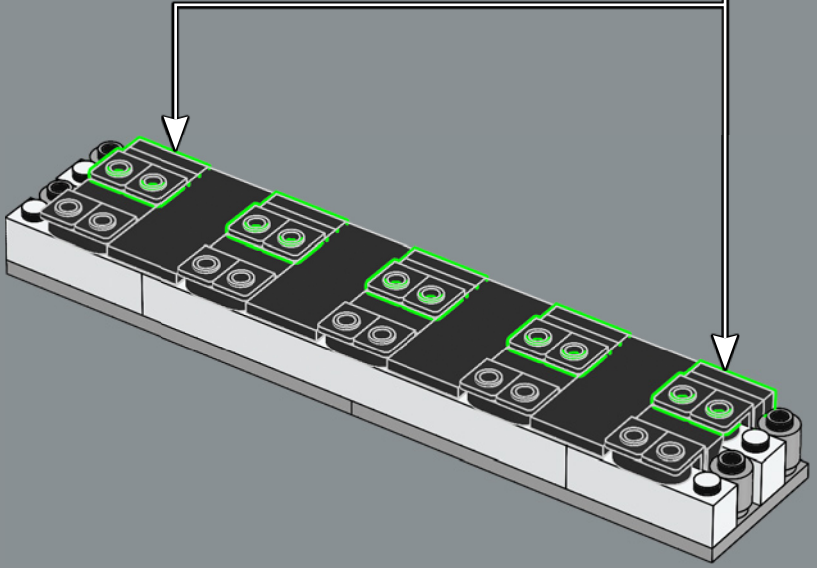
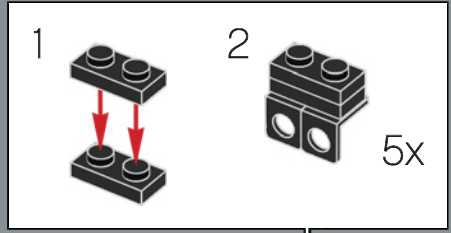

2x

215

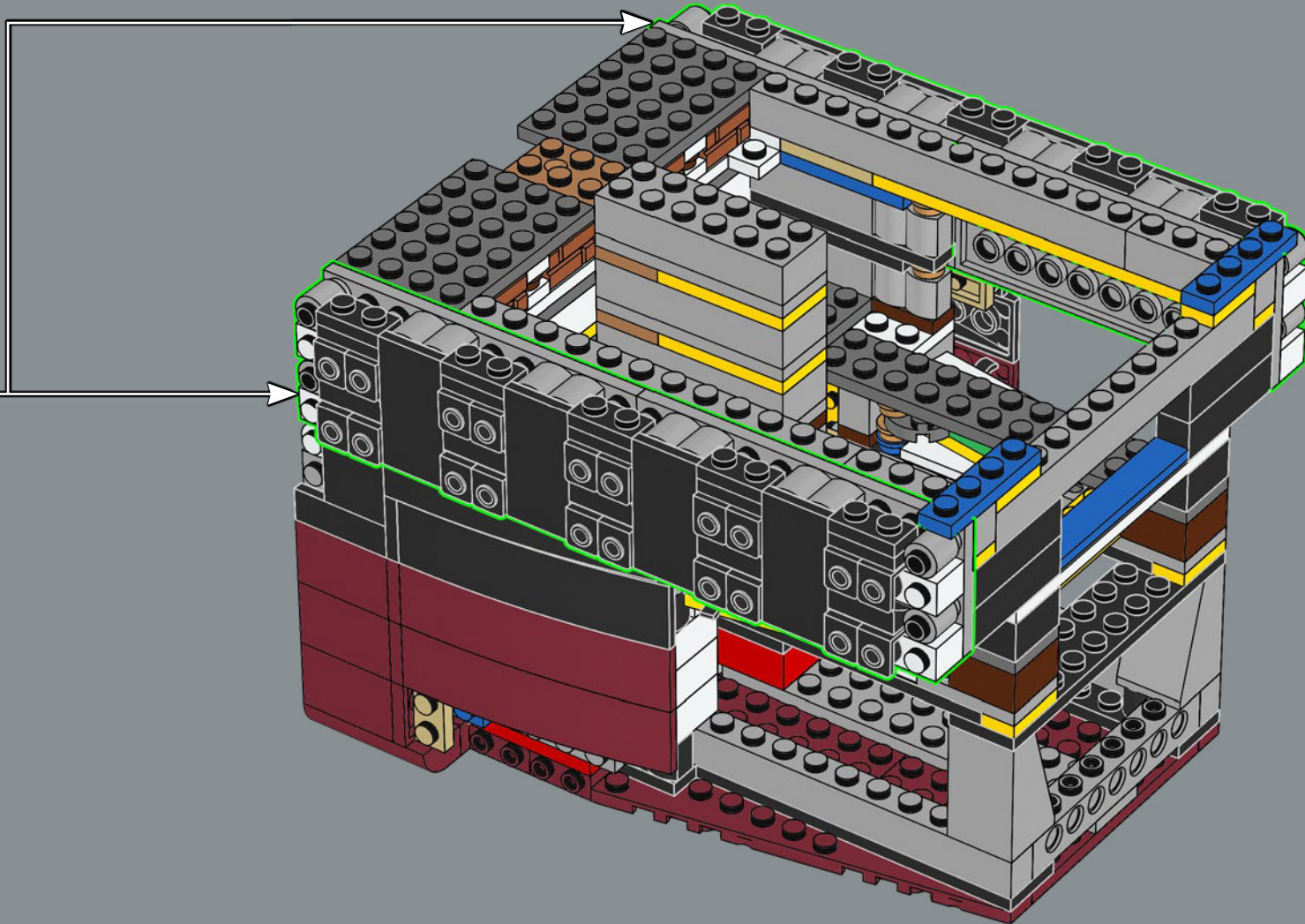

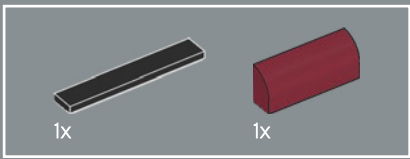

216

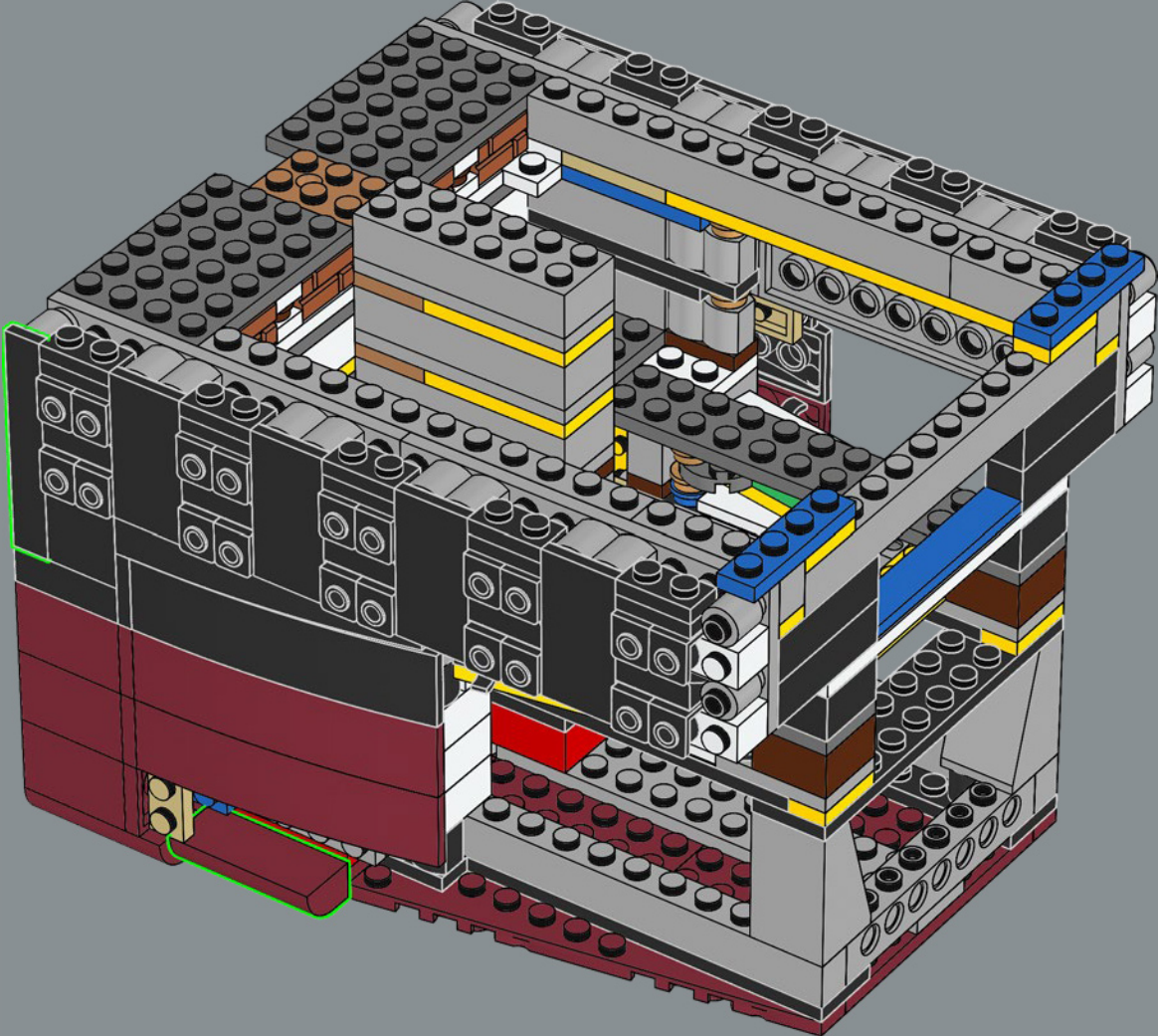

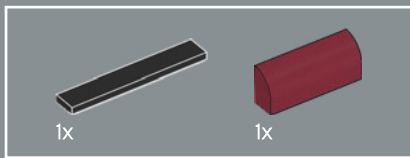

217

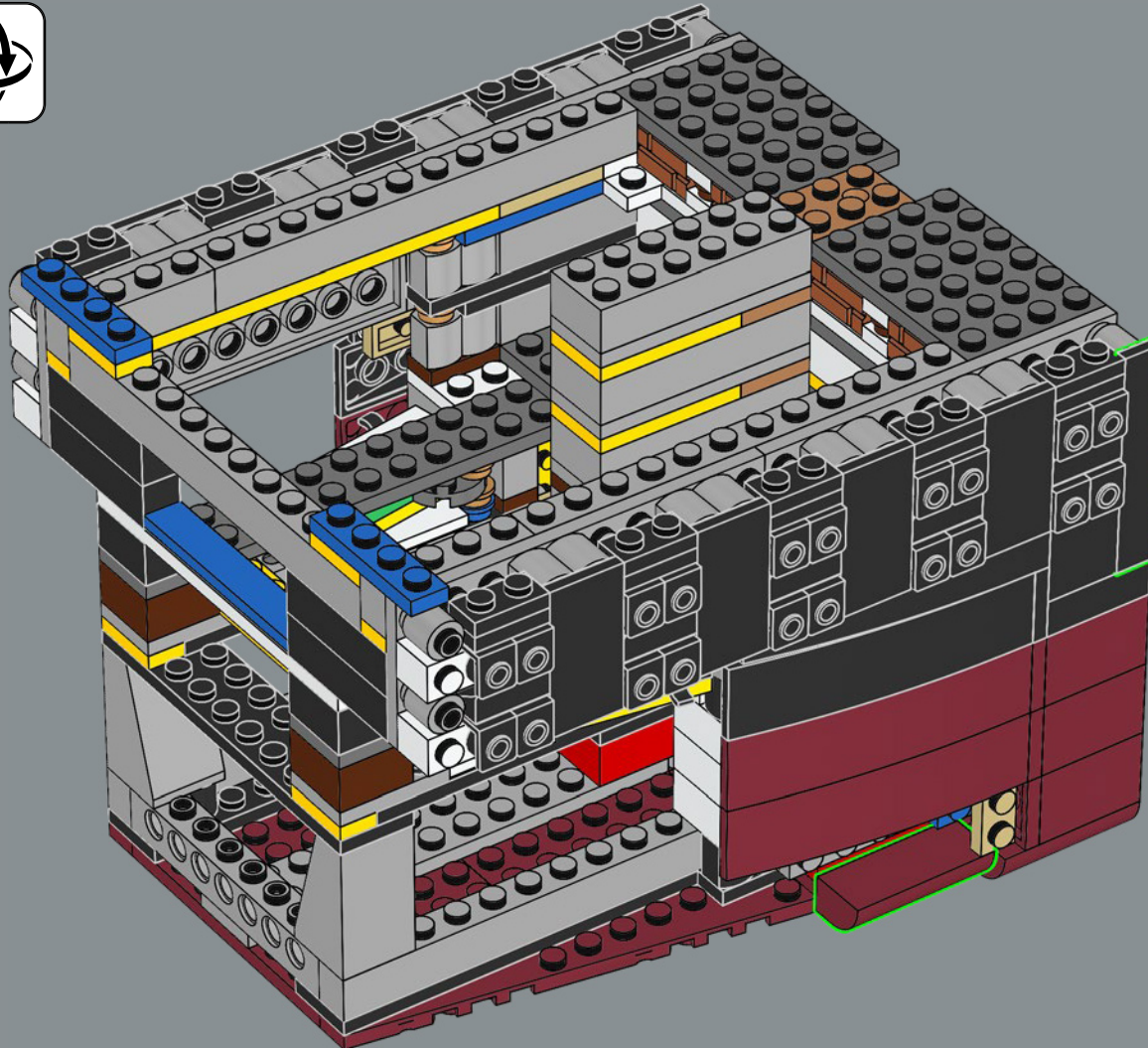

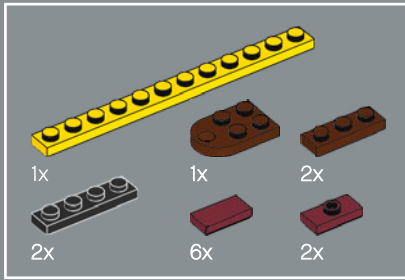
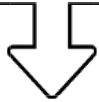

218

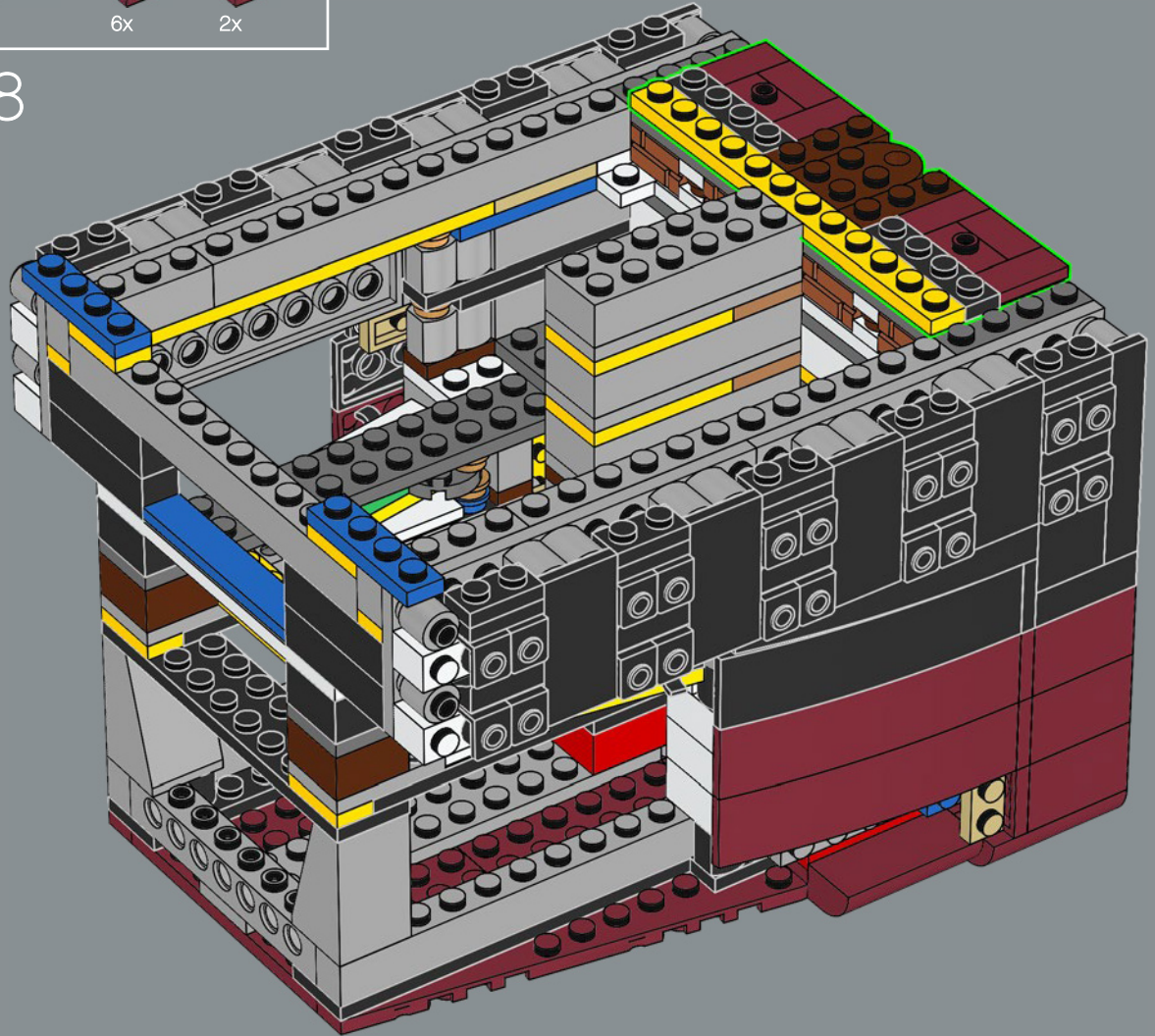



219

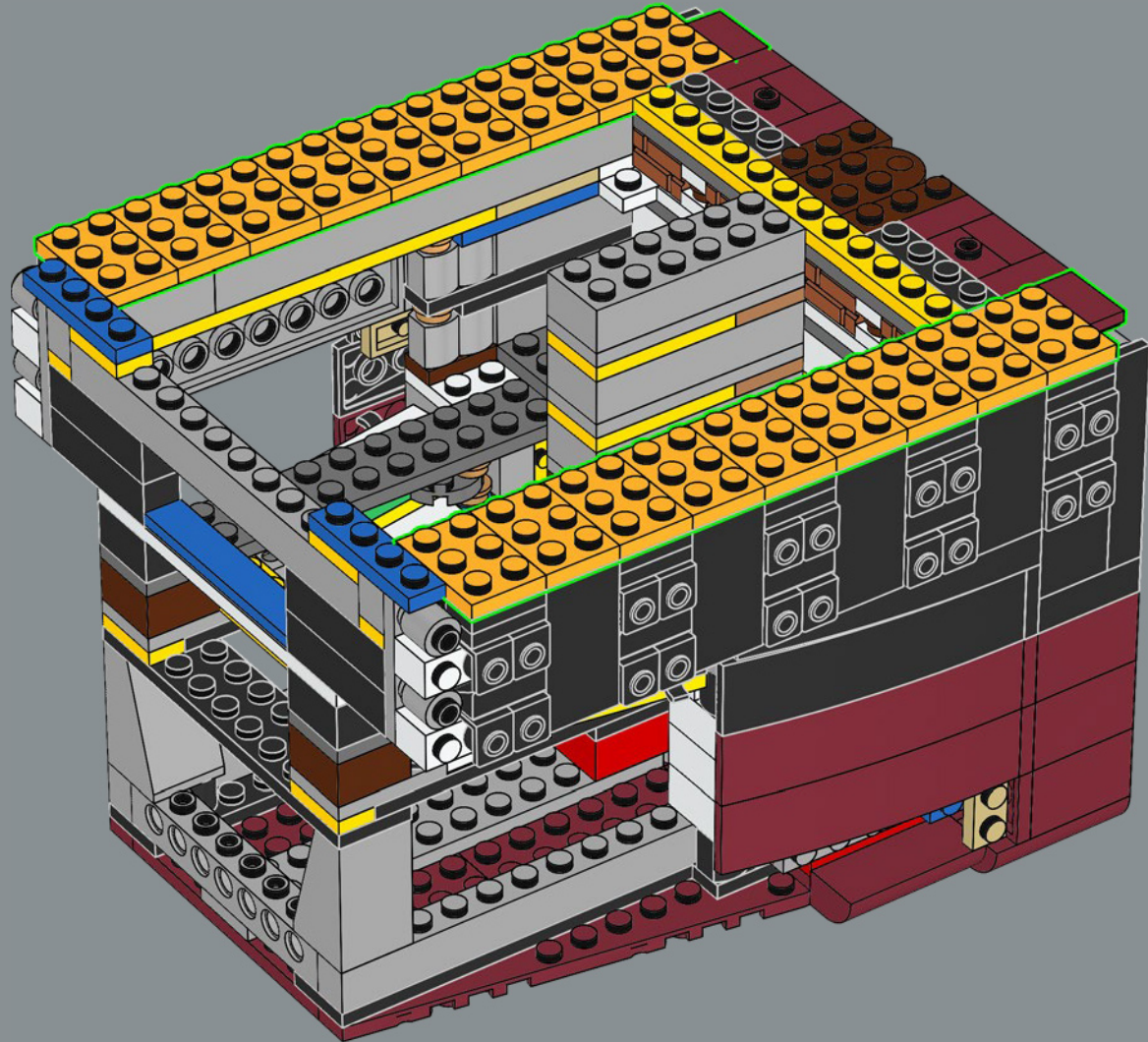

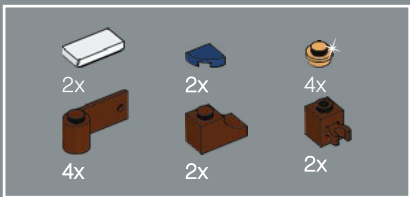

220

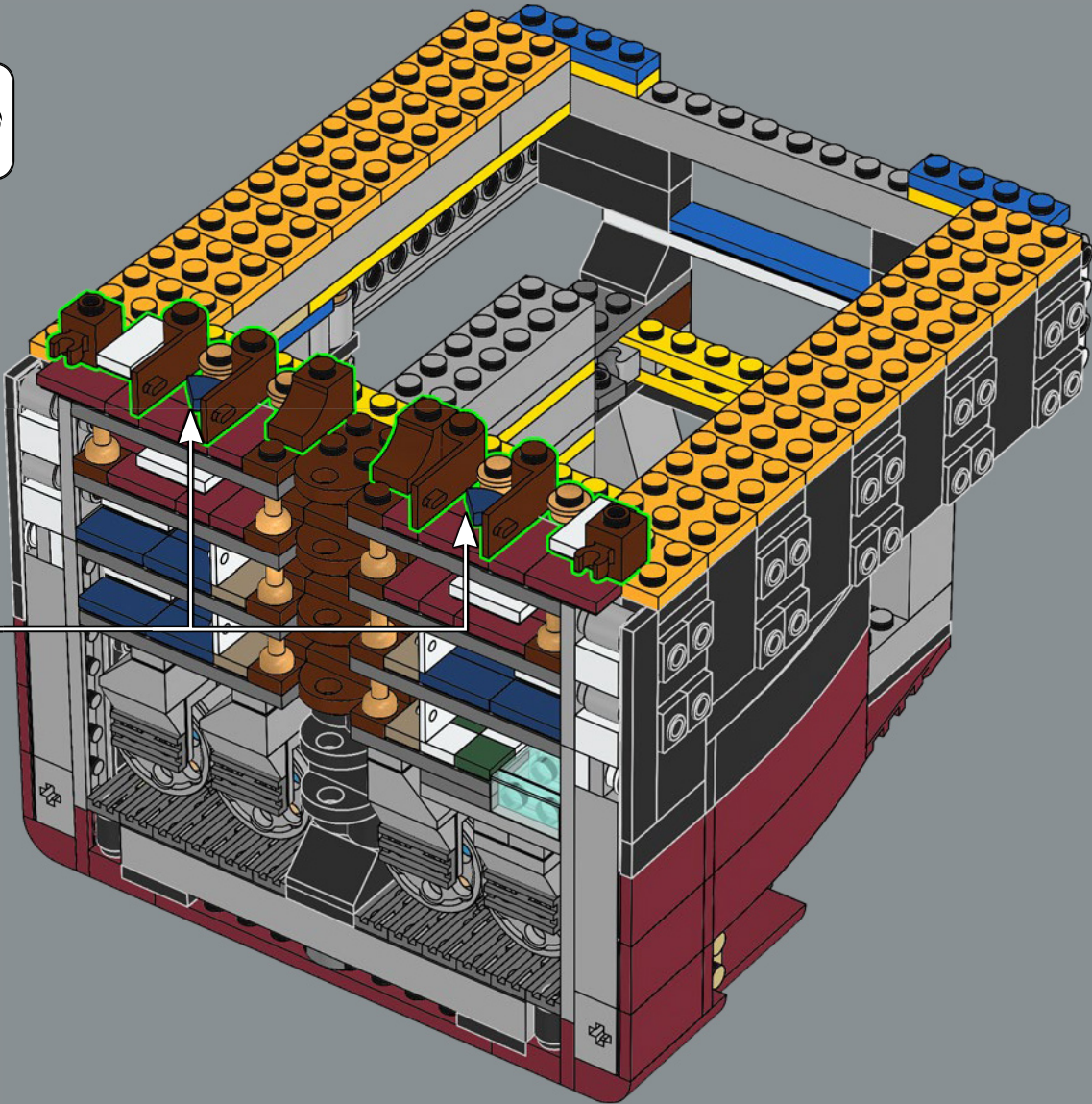

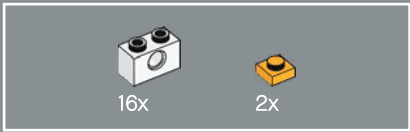

222

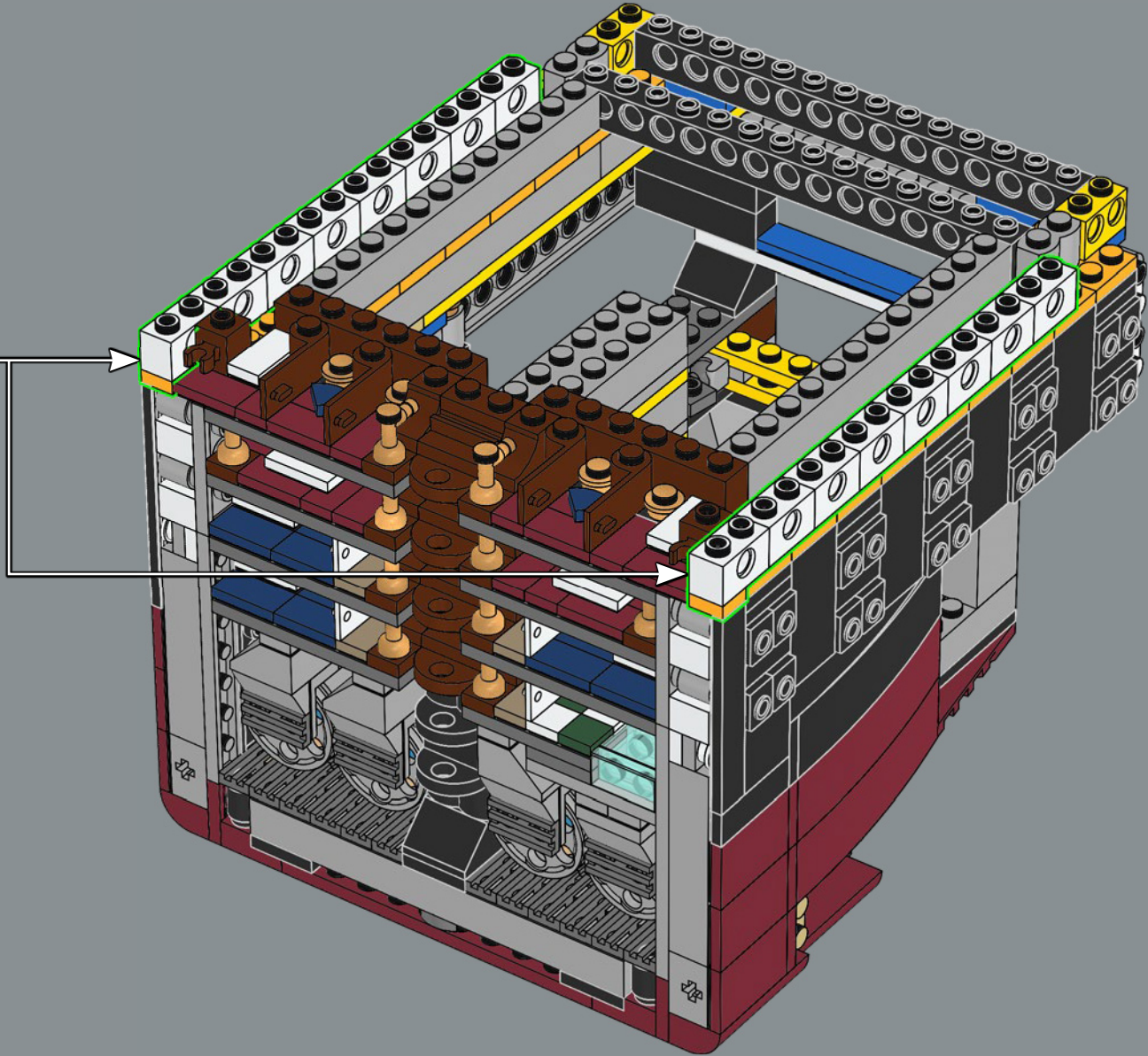
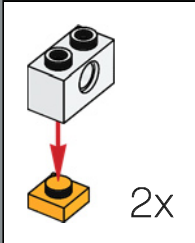

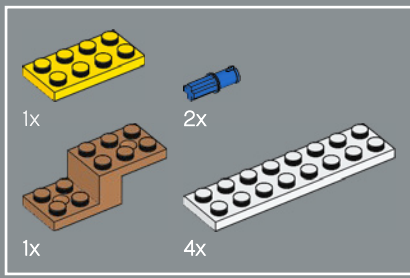

223

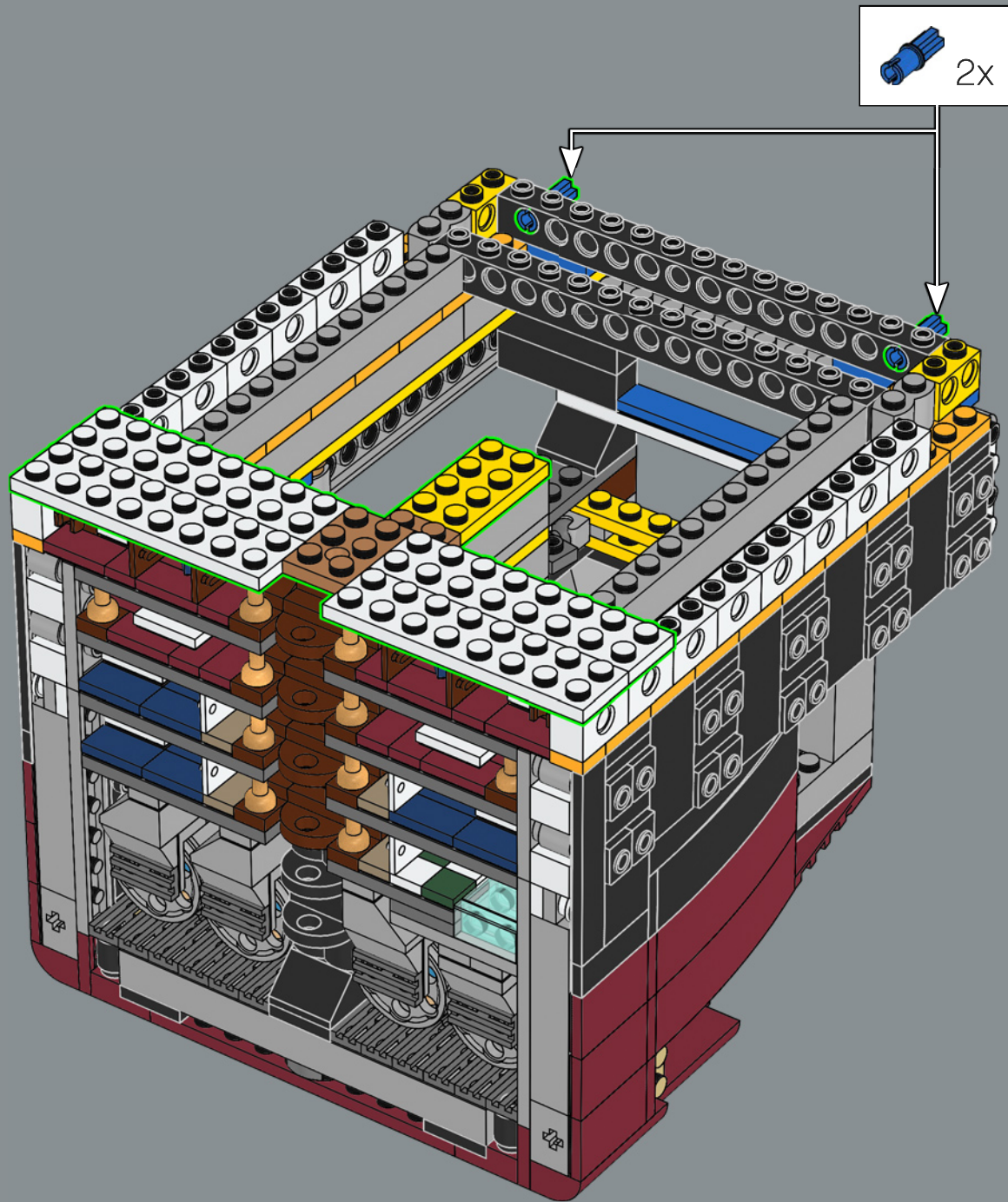

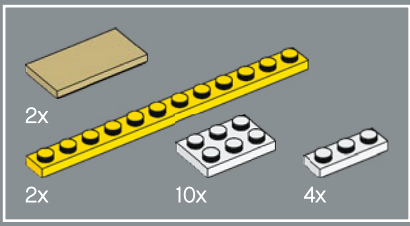

224

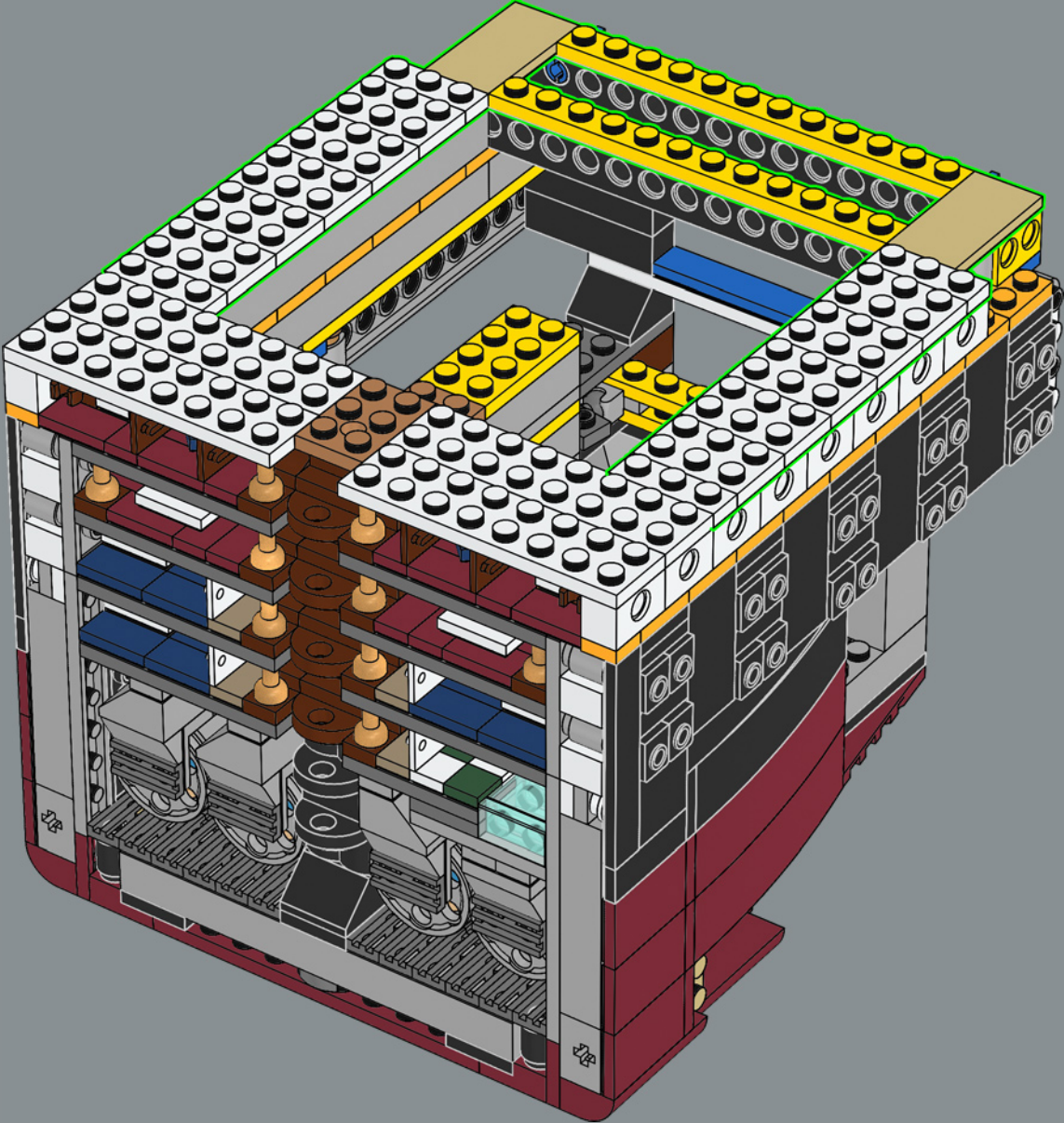

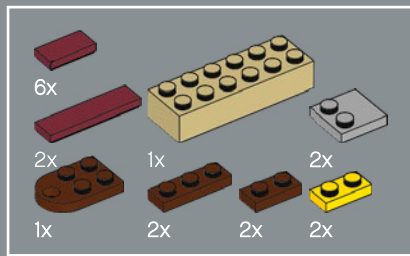

225

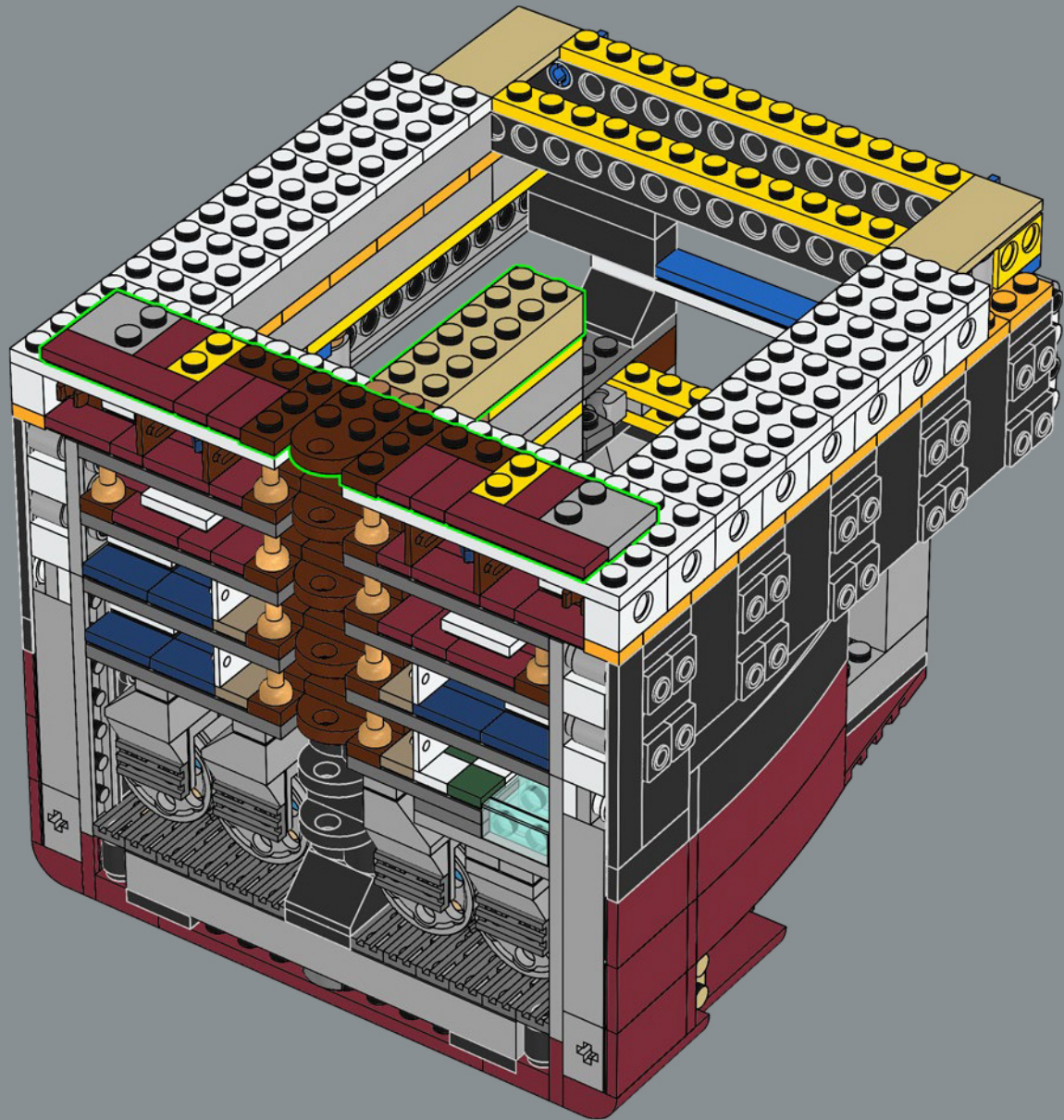

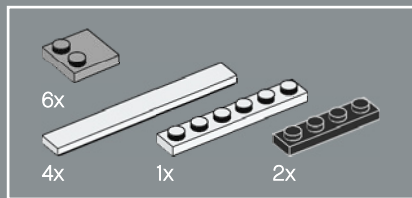

226

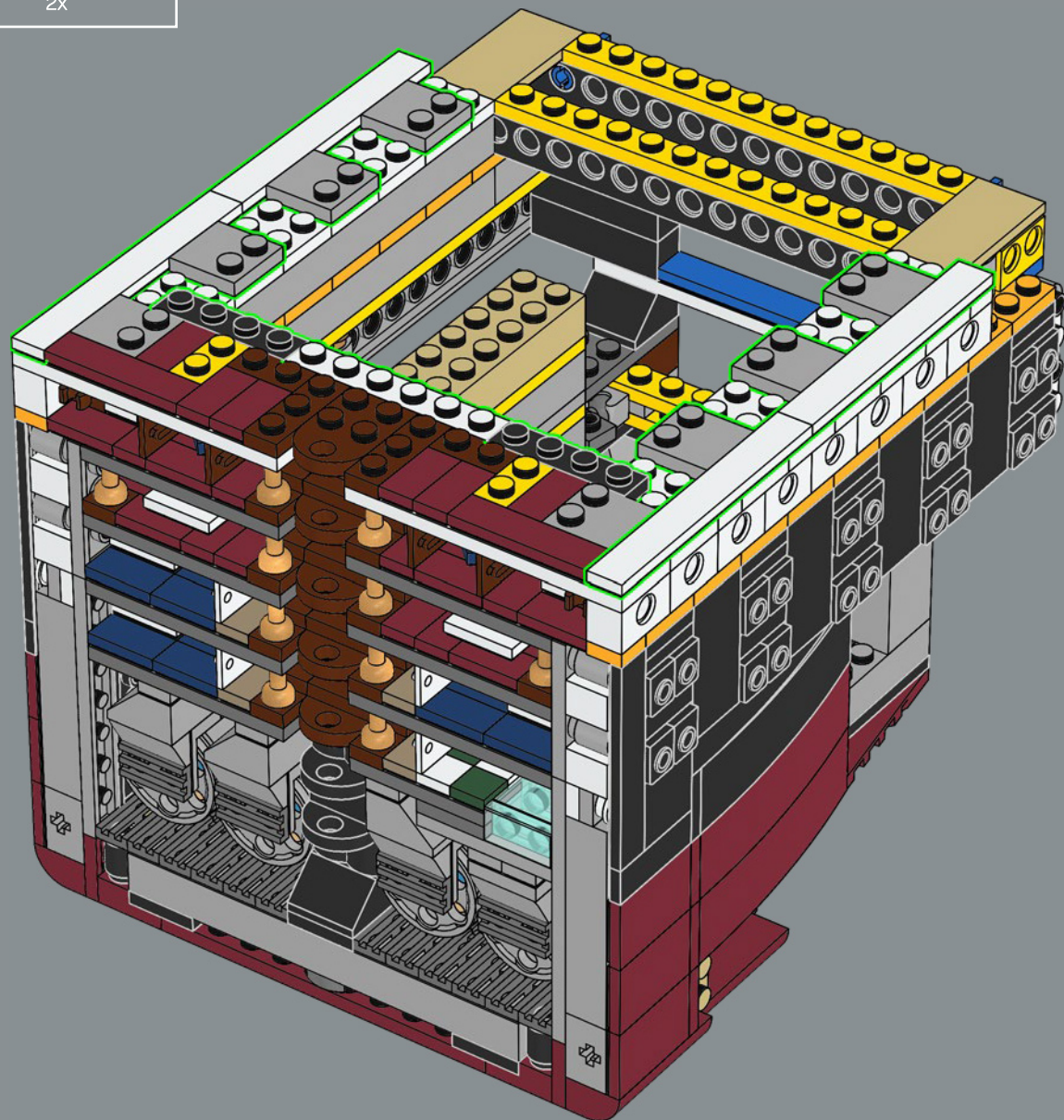

"RMS" in *RMS Titanic* sta per "Royal Mail Ship" (regia nave postale) in quanto la nave trasportava una grande quantità di merci sia per il servizio postale britannico, Royal Mail, sia per quello degli Stati Uniti.

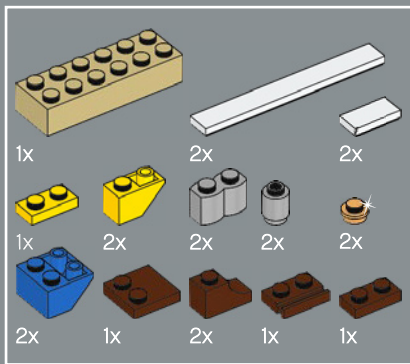

227

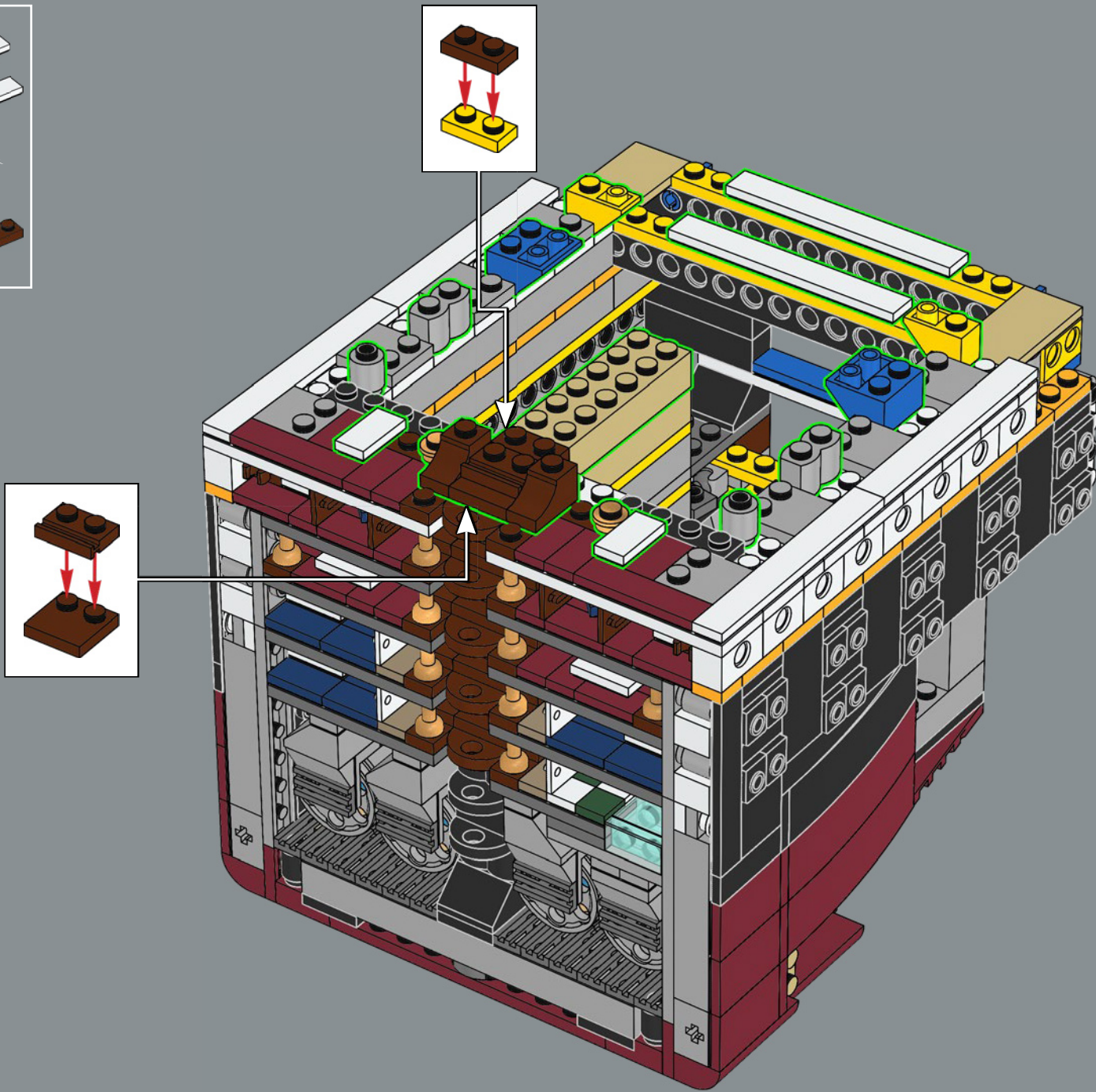

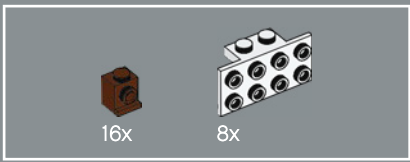

228

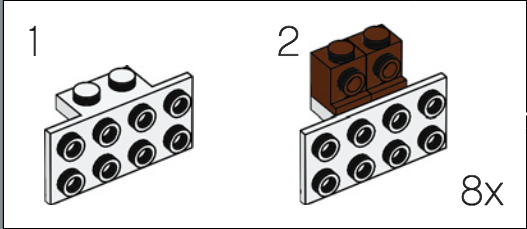
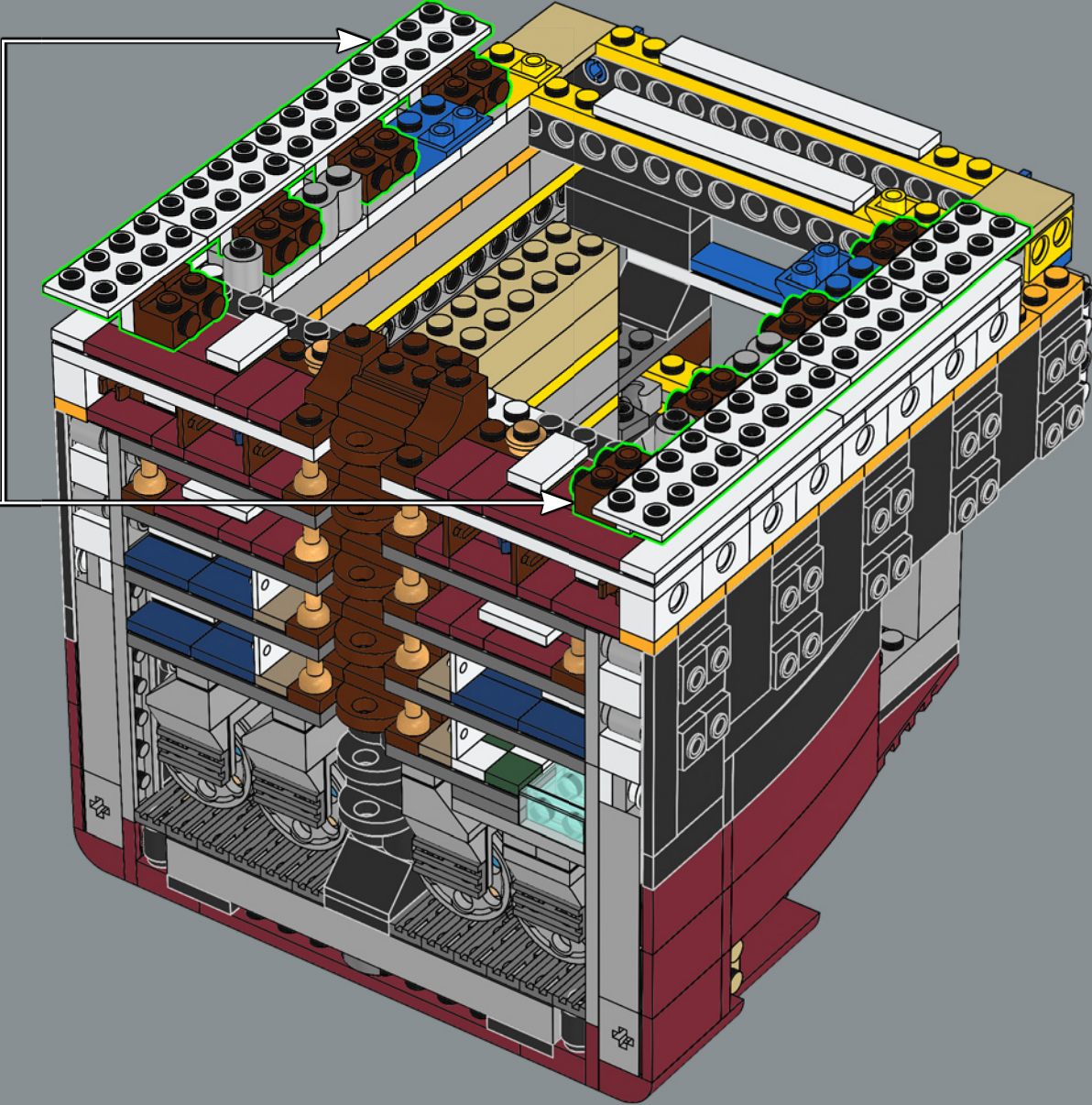

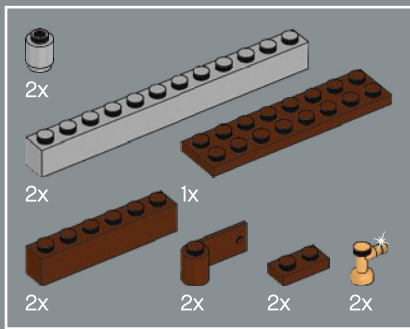

229

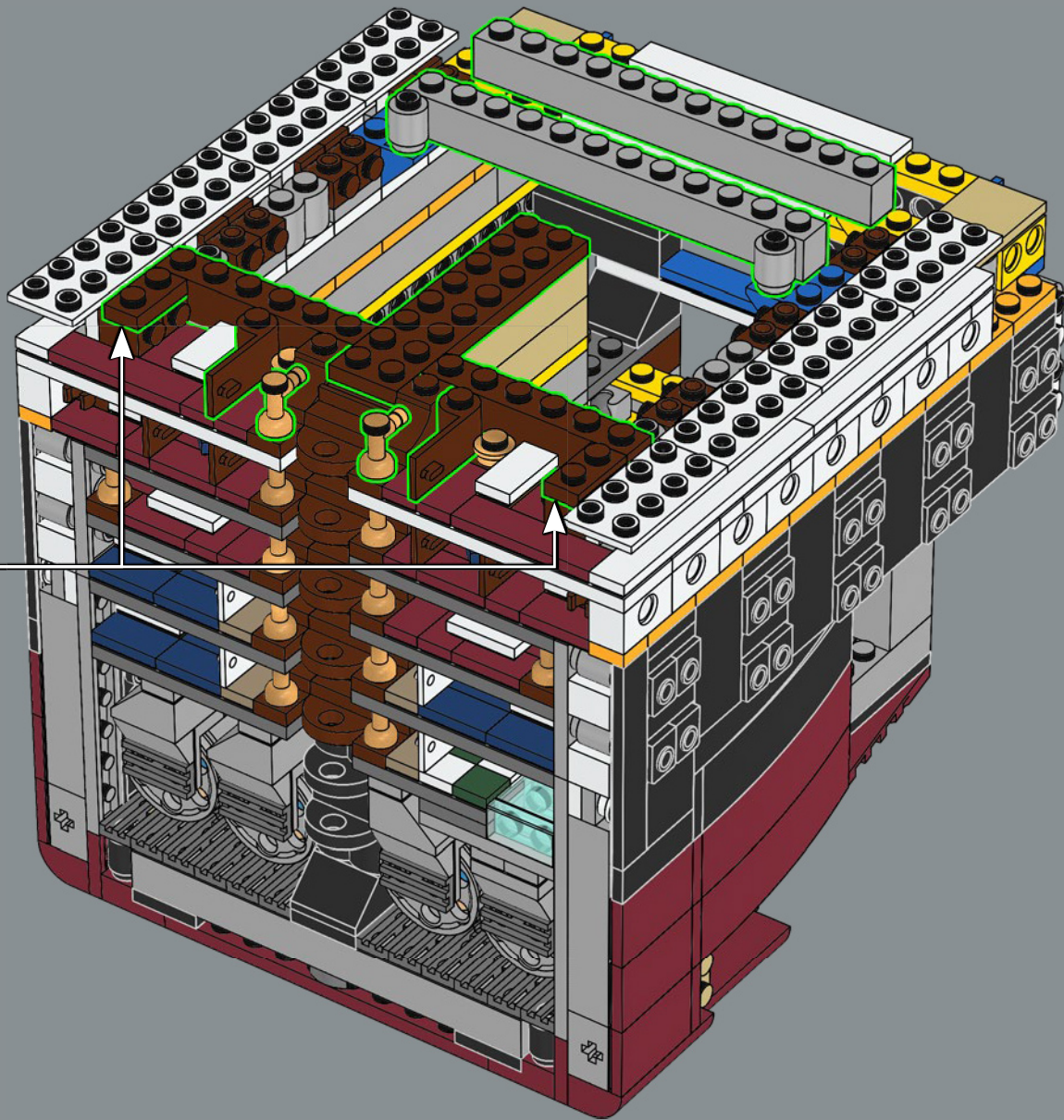

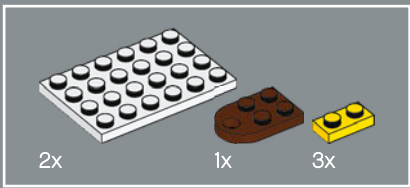

230

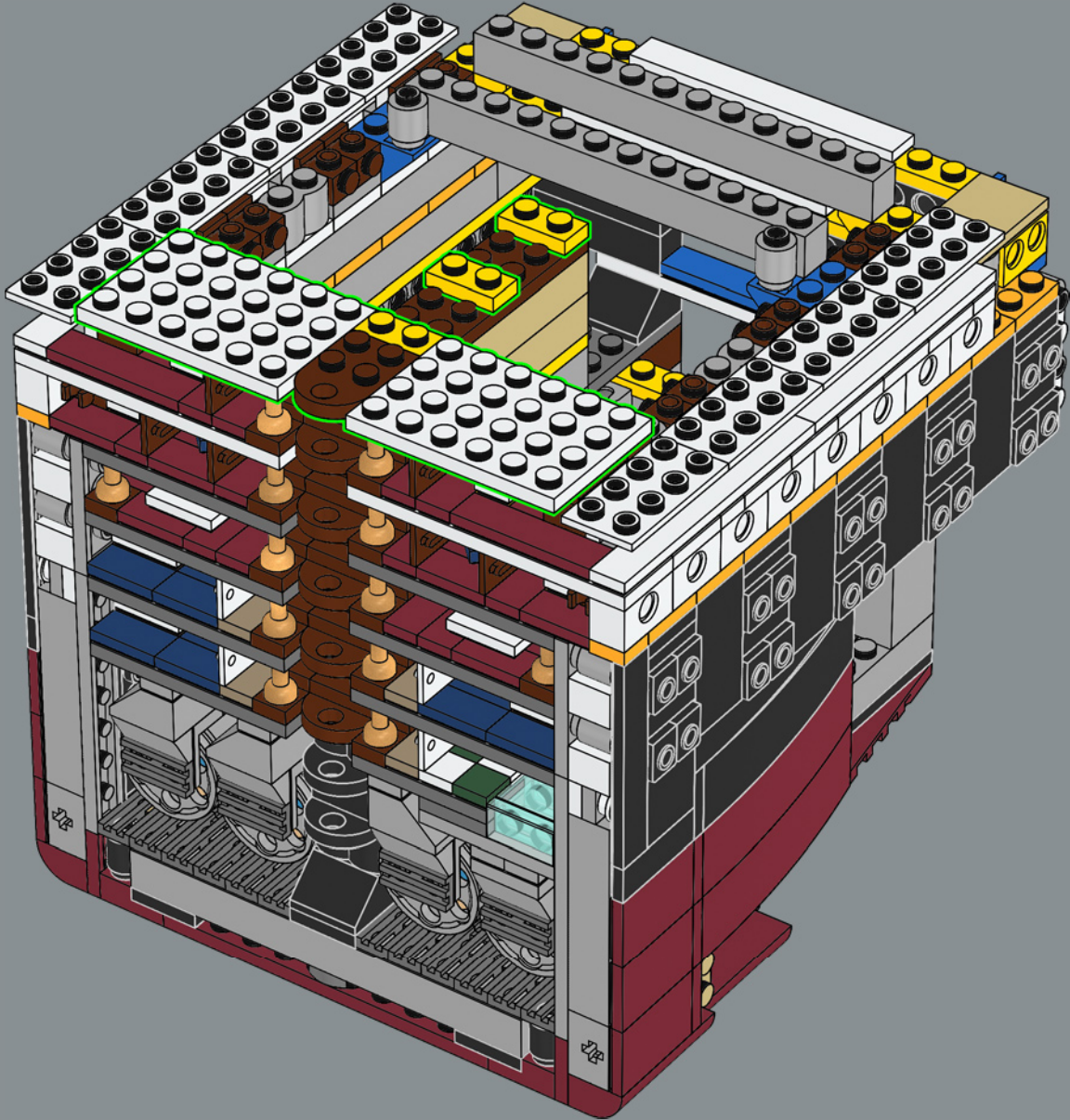

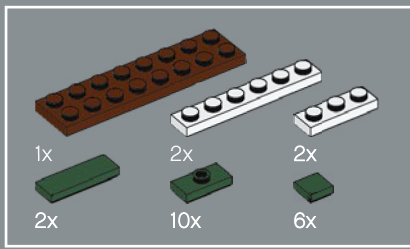

231

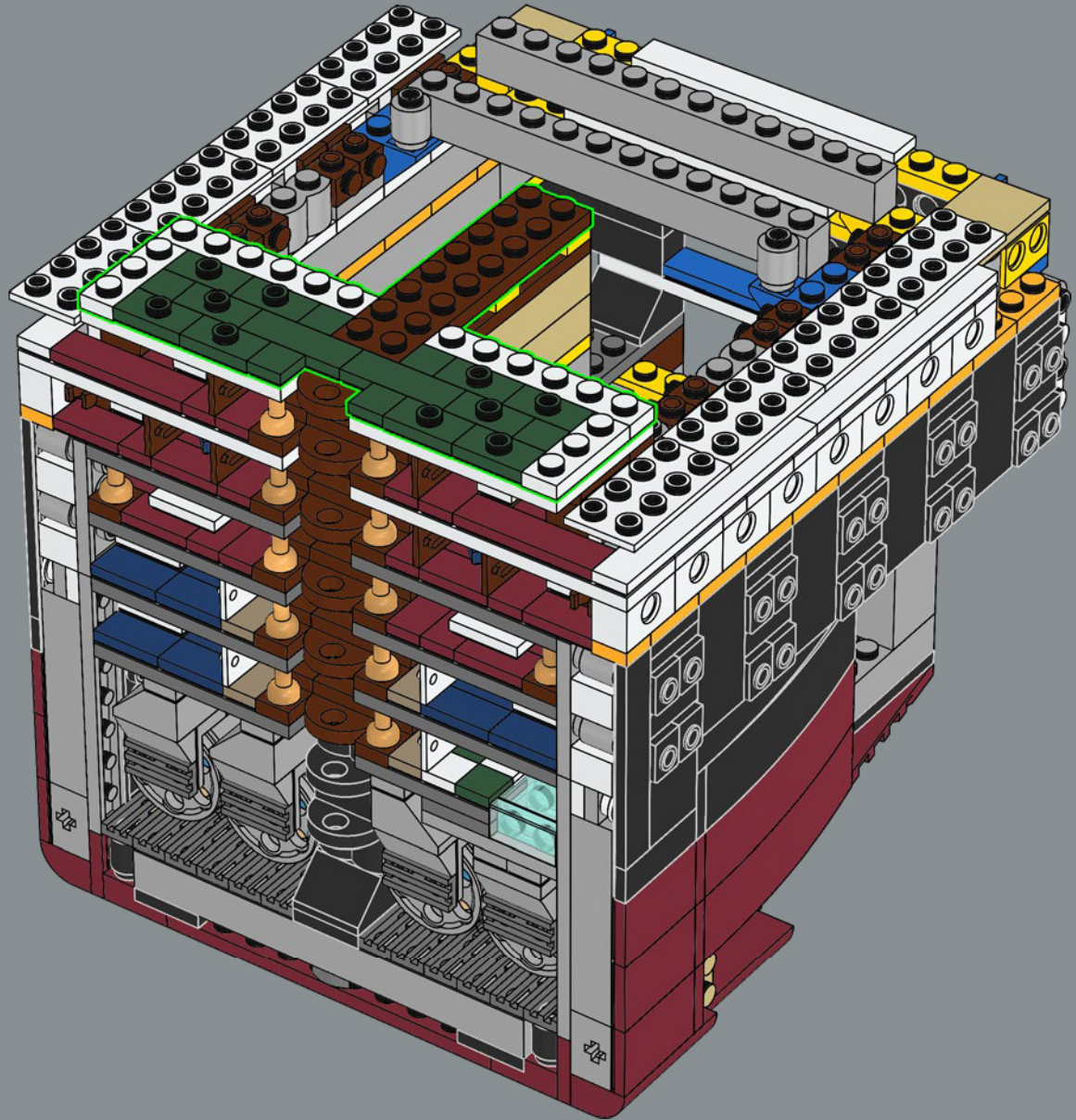

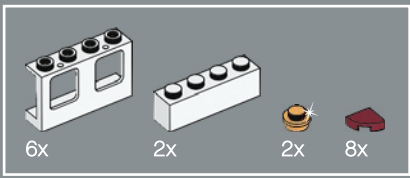

232

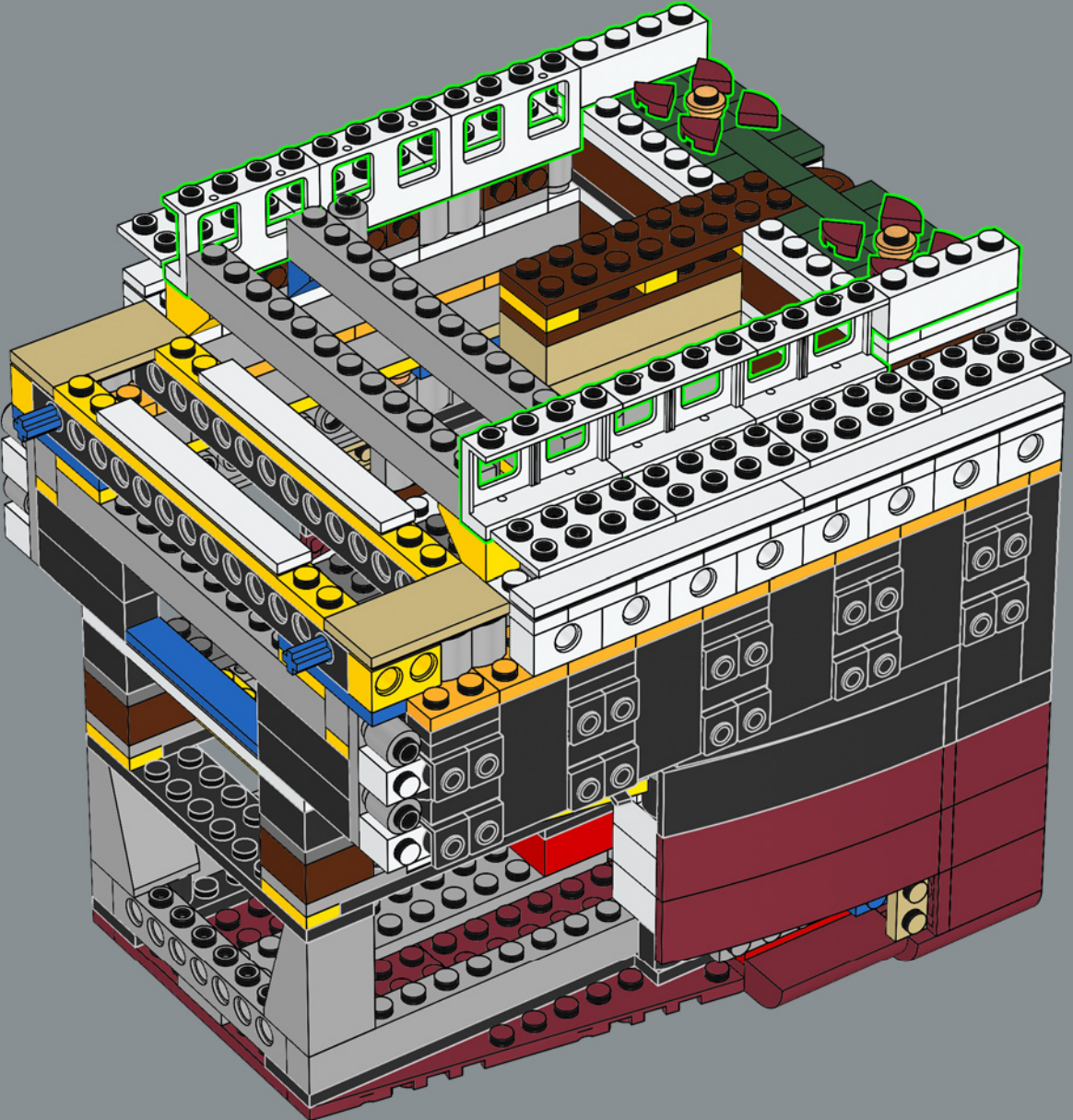

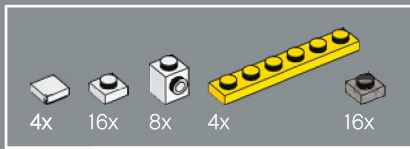

233

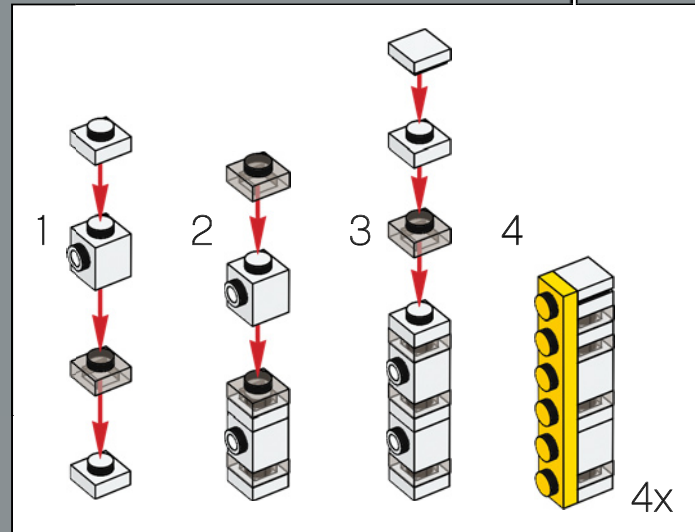
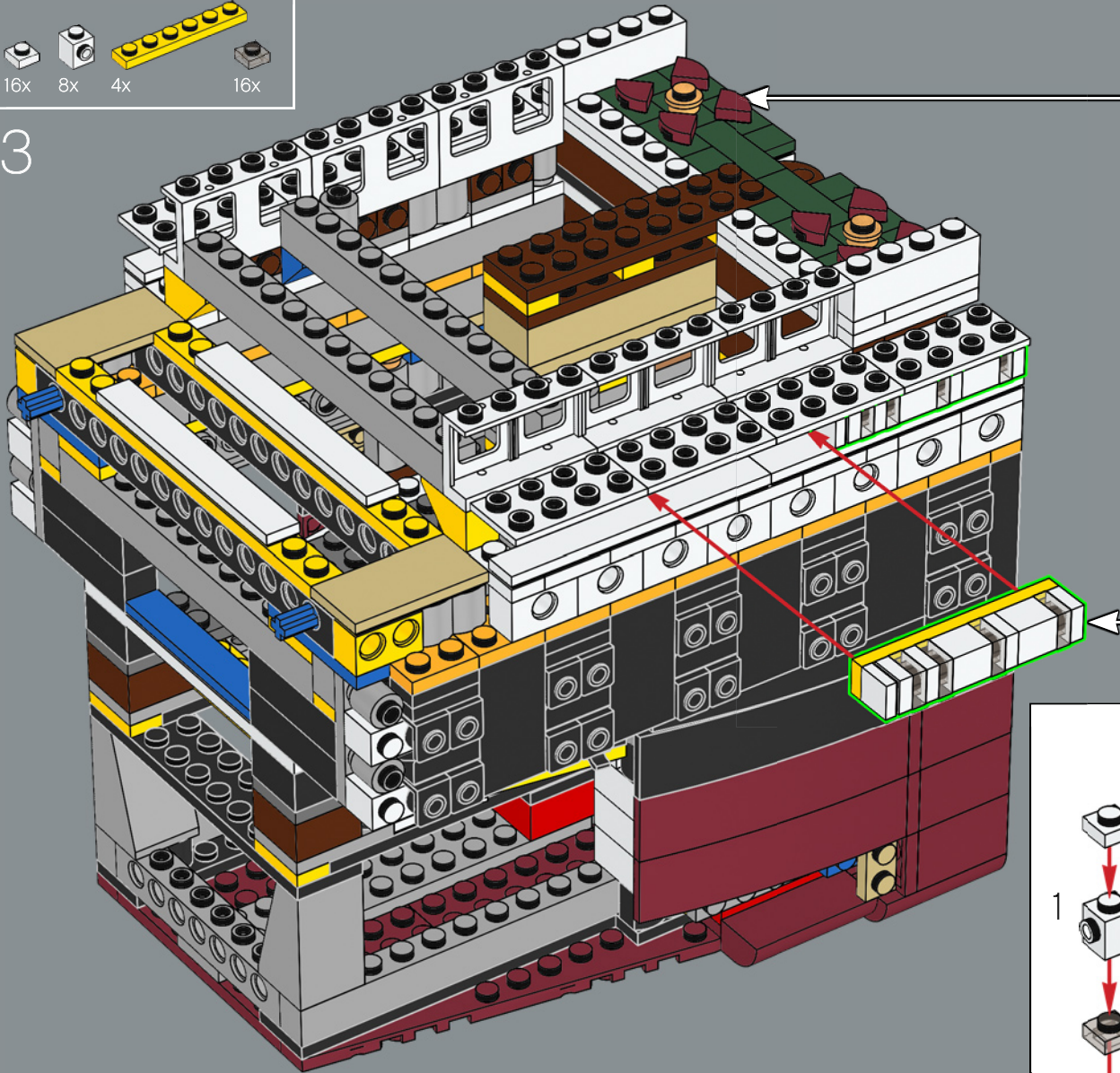

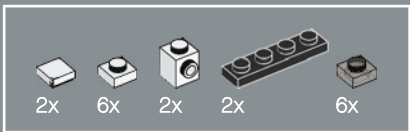

234

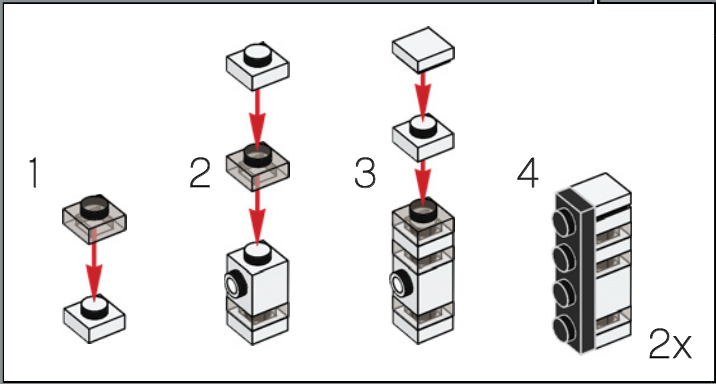
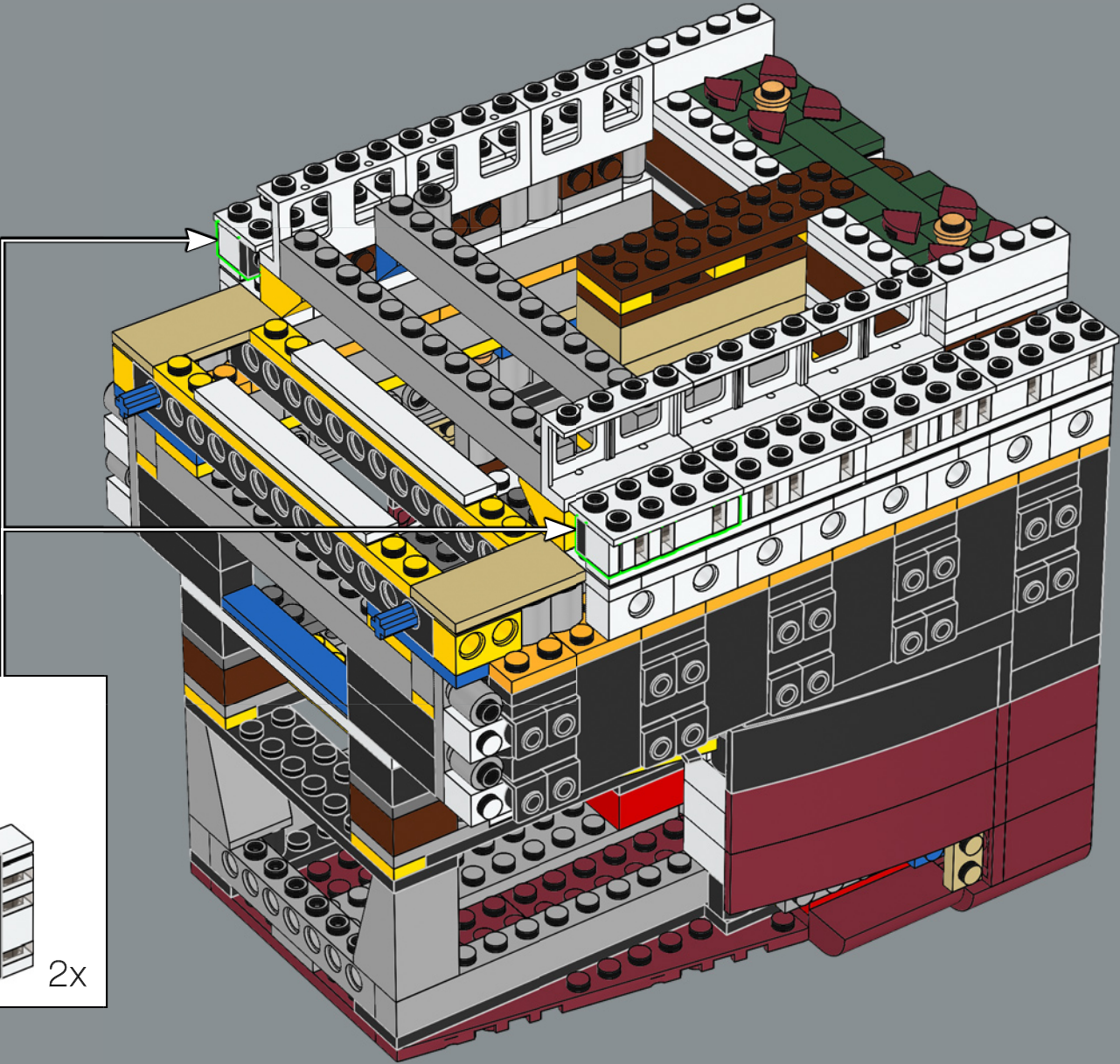

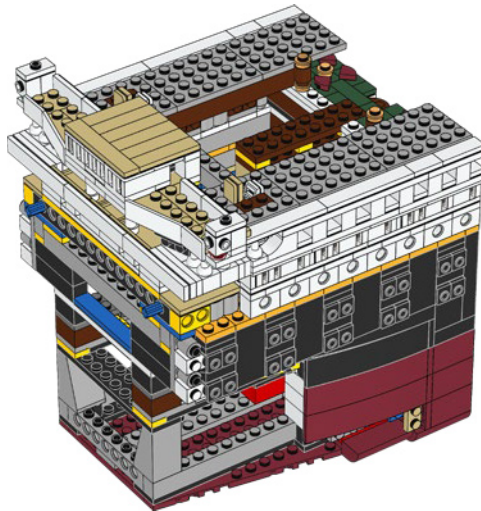
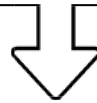

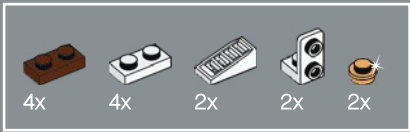

235

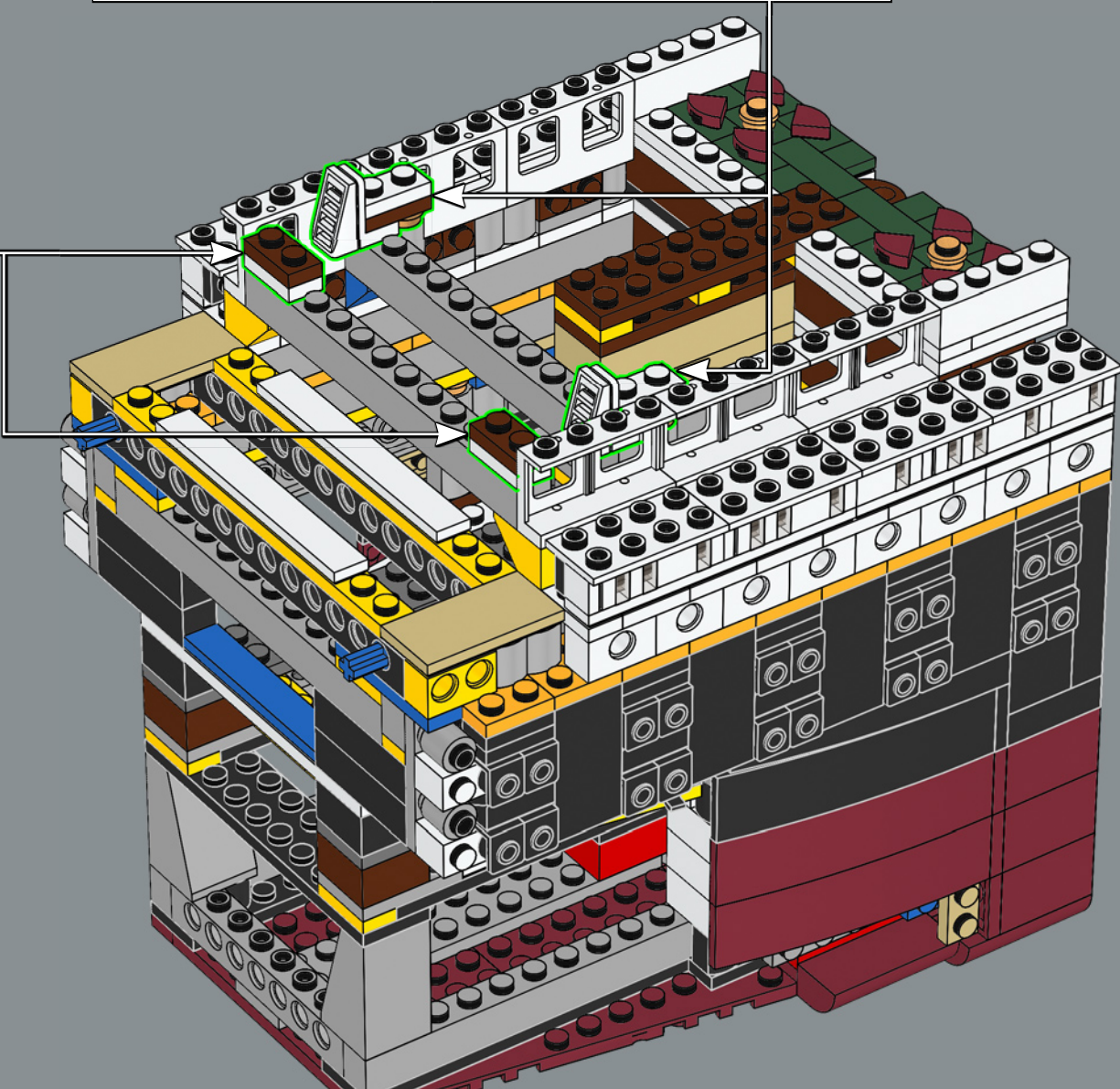
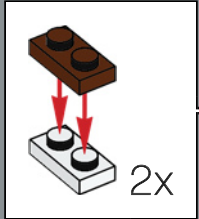
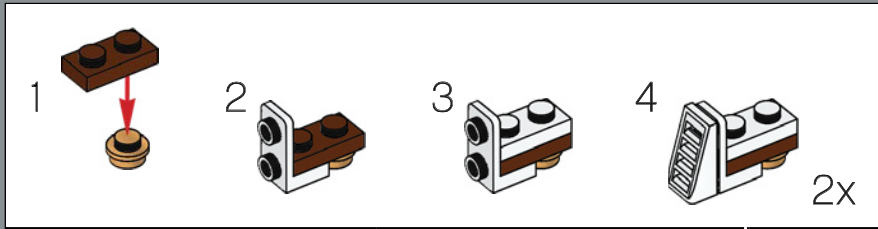

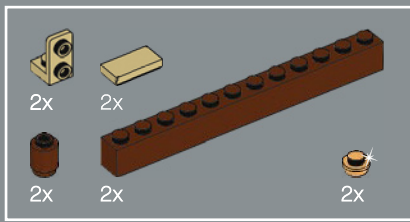

236

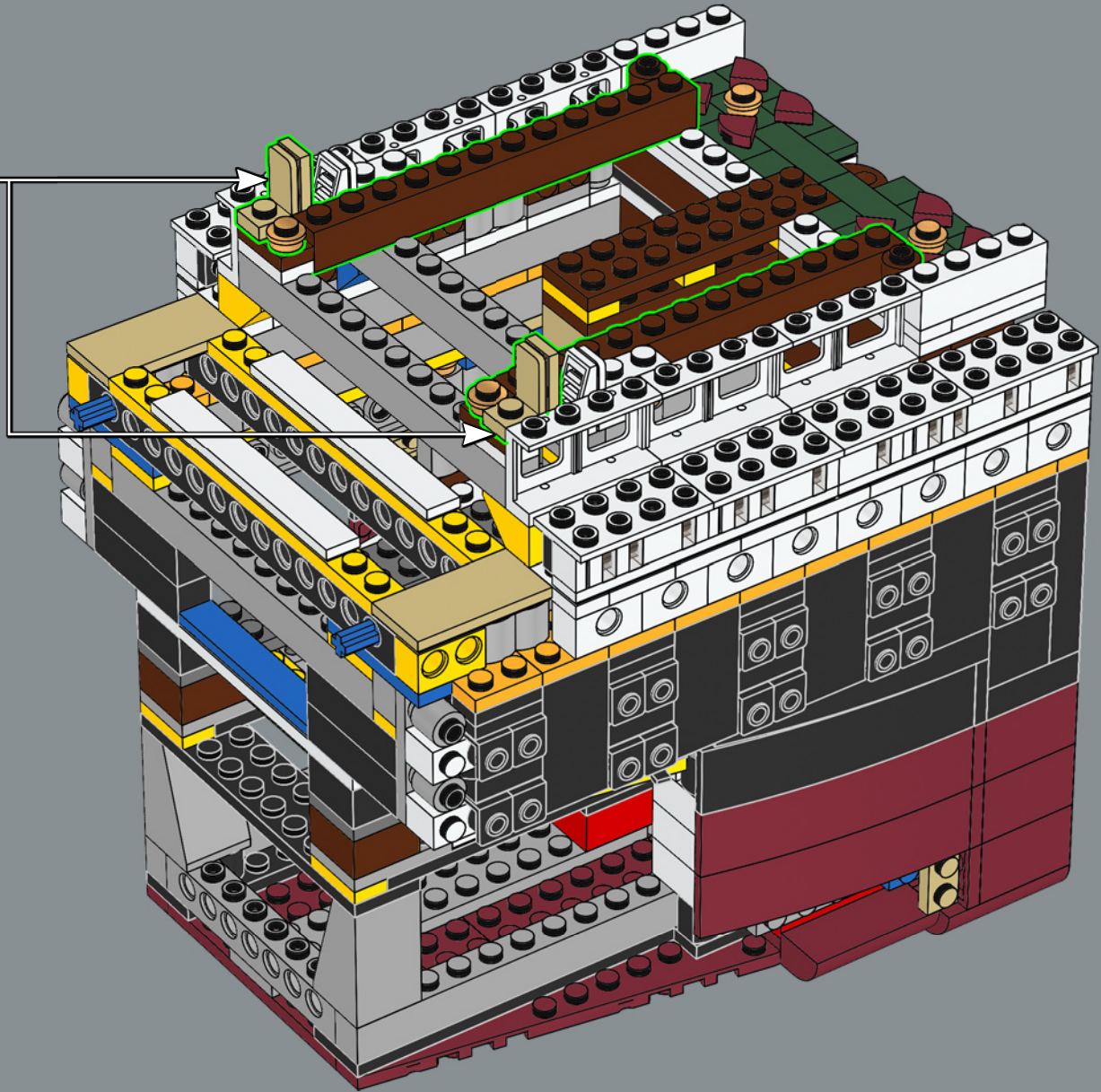
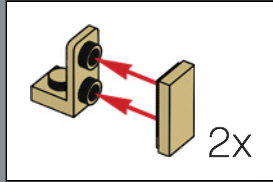

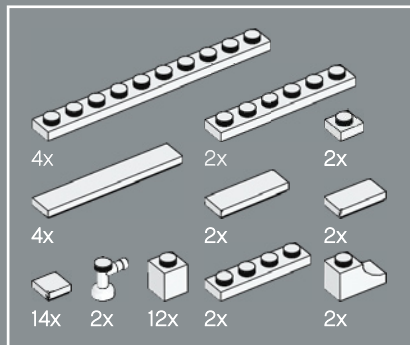
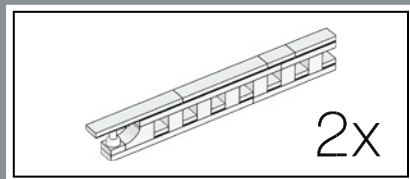

237

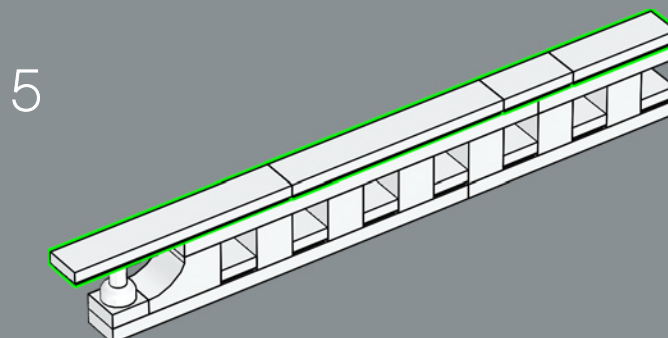
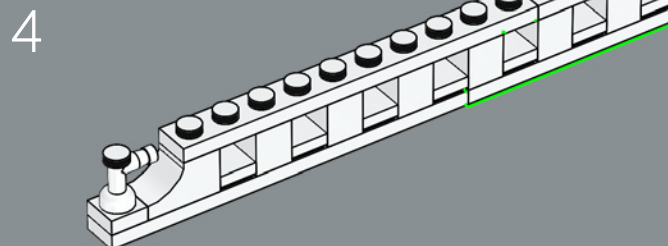
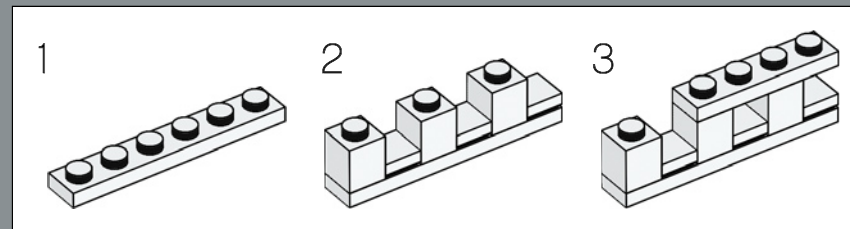
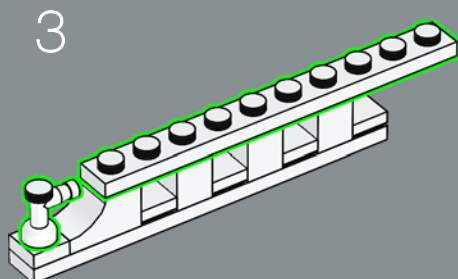
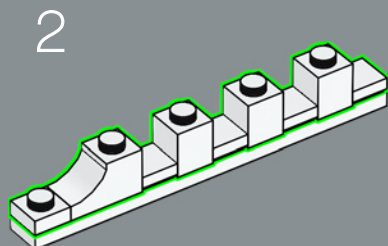
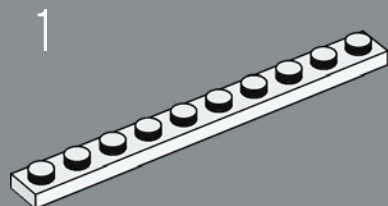

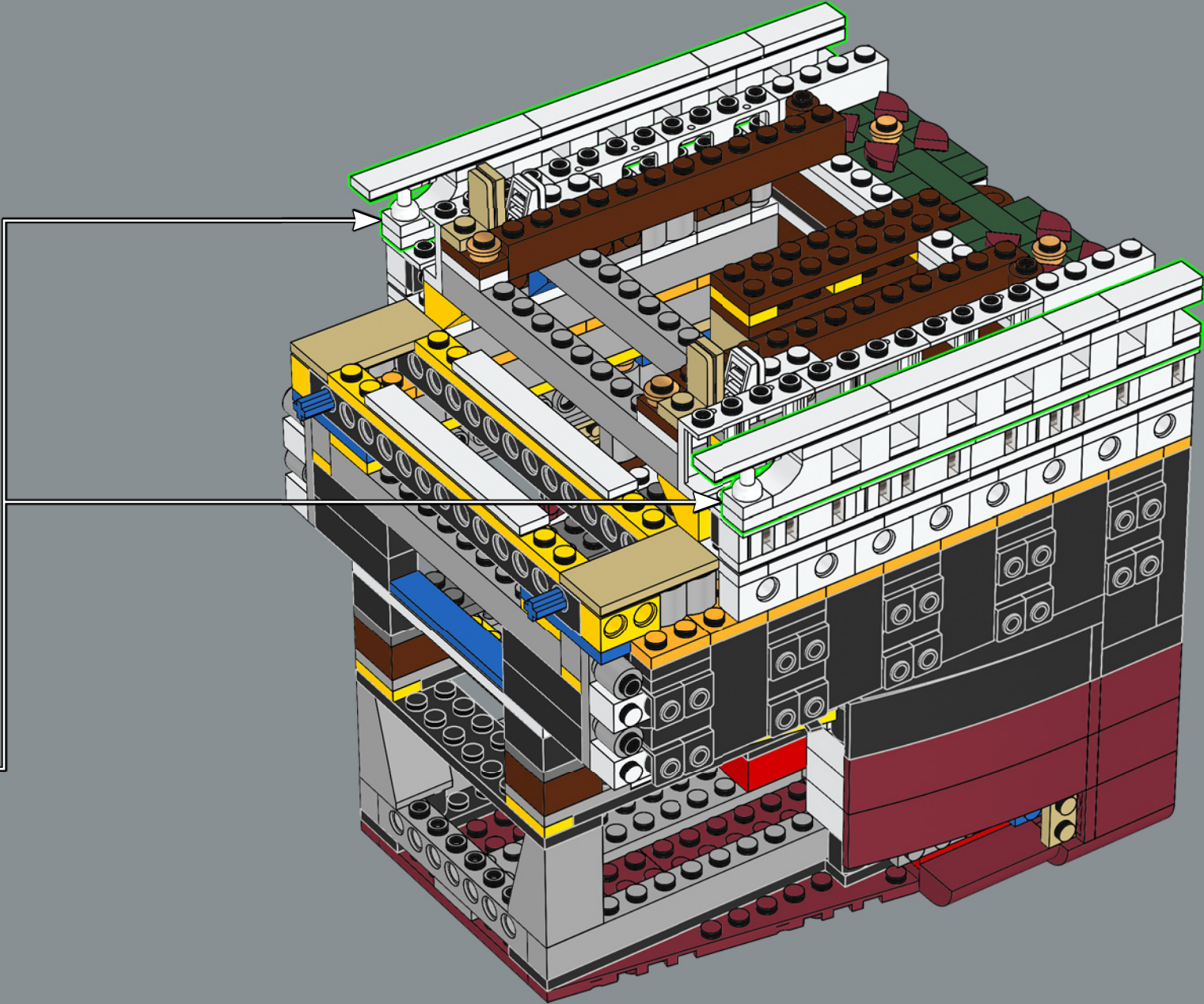

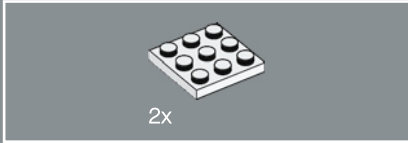
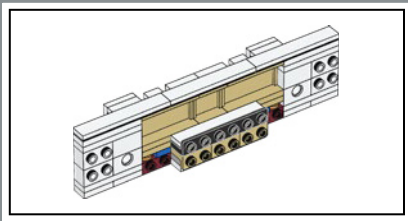

238

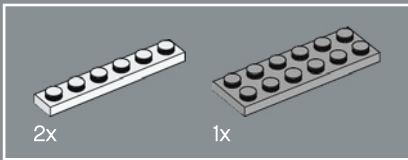
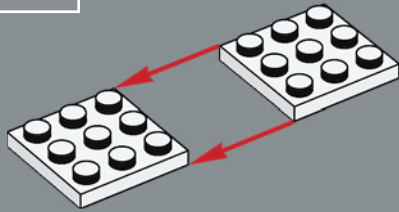

239

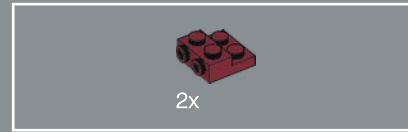
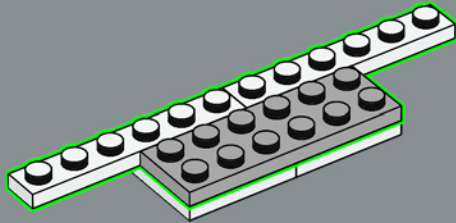

240

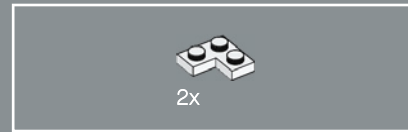
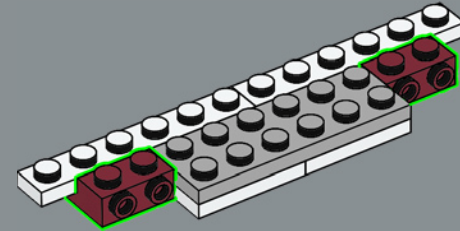

241

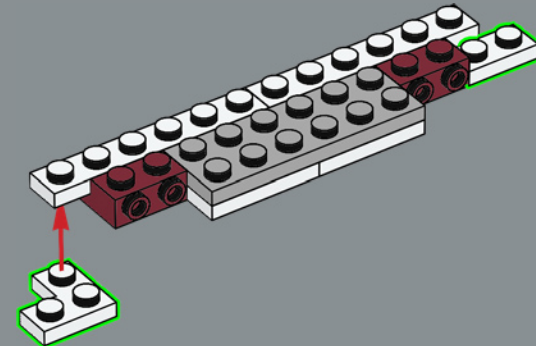

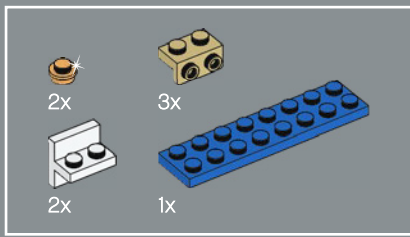

242

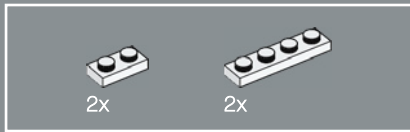
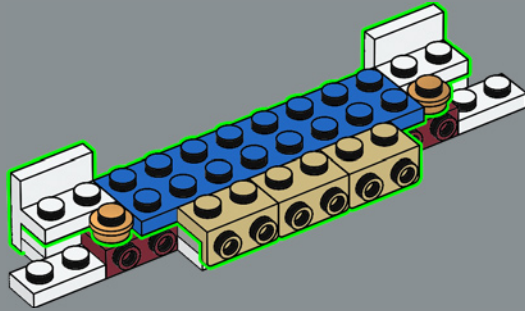

243

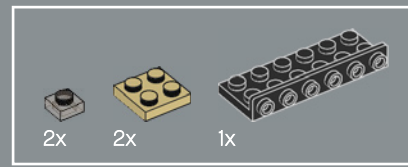
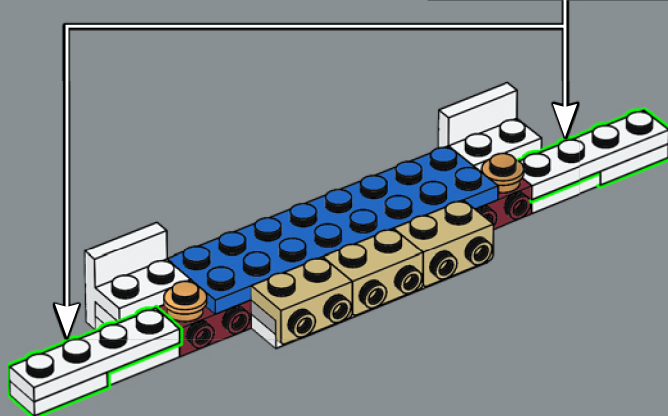
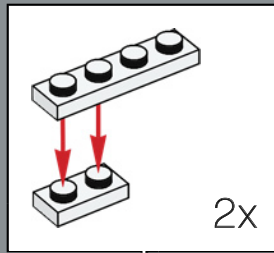

244

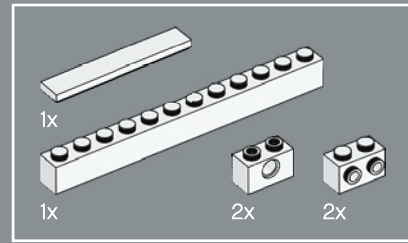
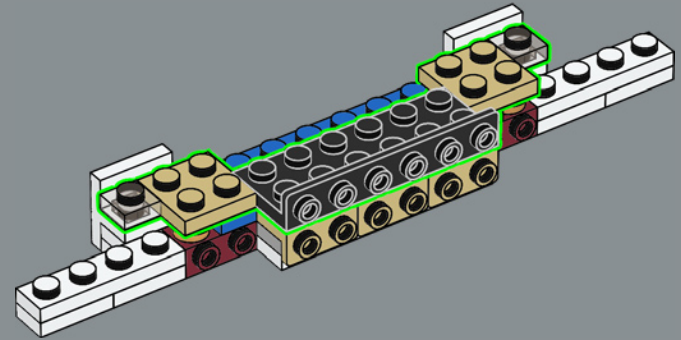

245

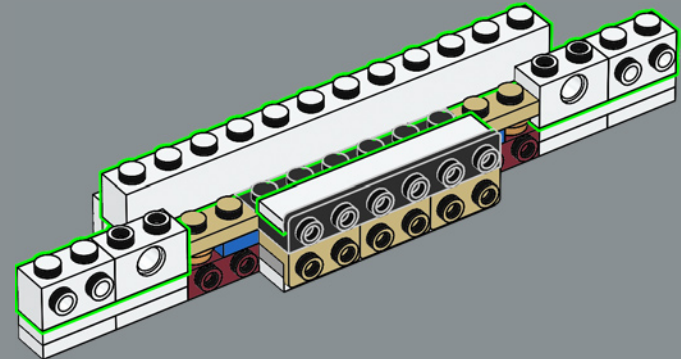

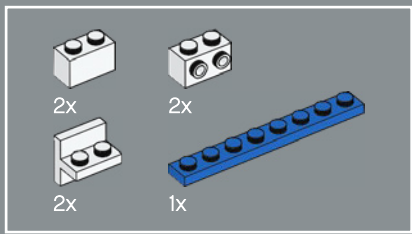

246

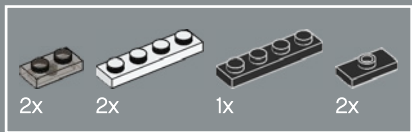
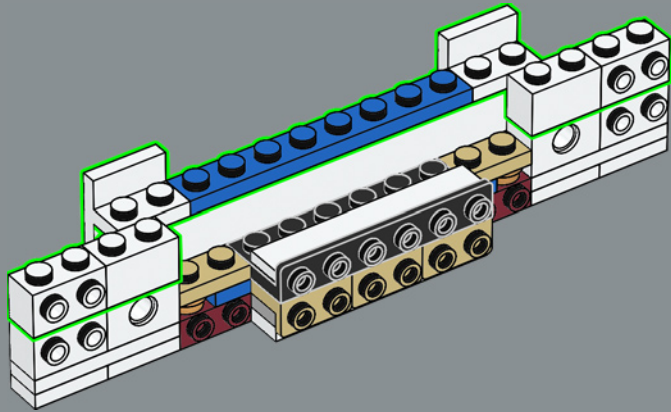

247

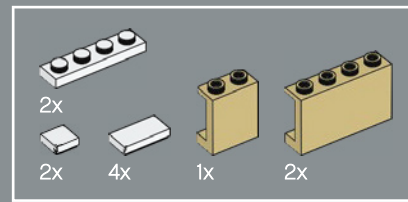
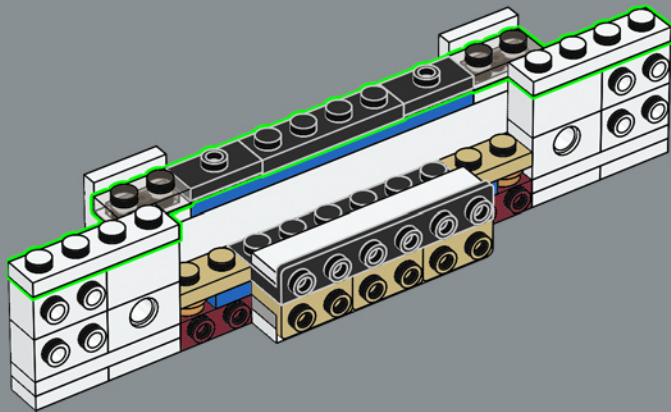

248

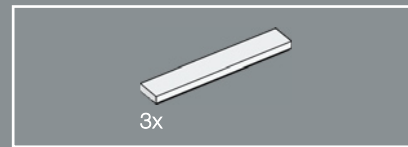
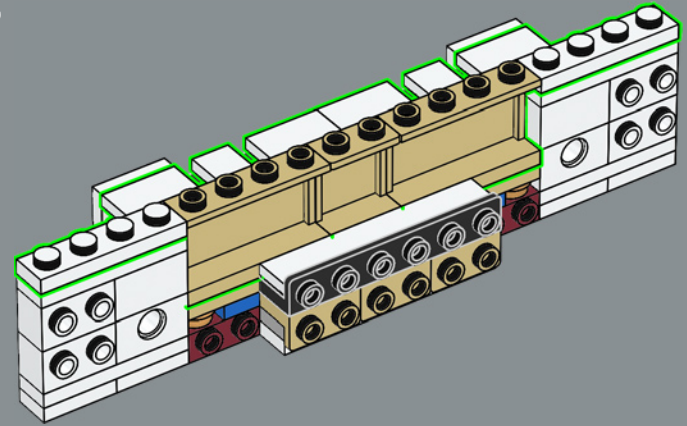

249

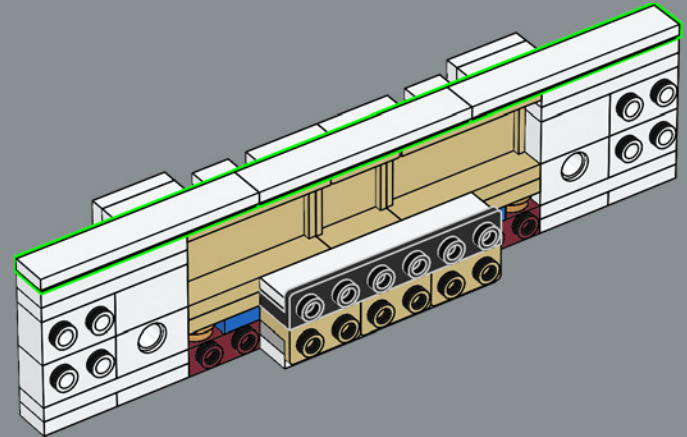

250

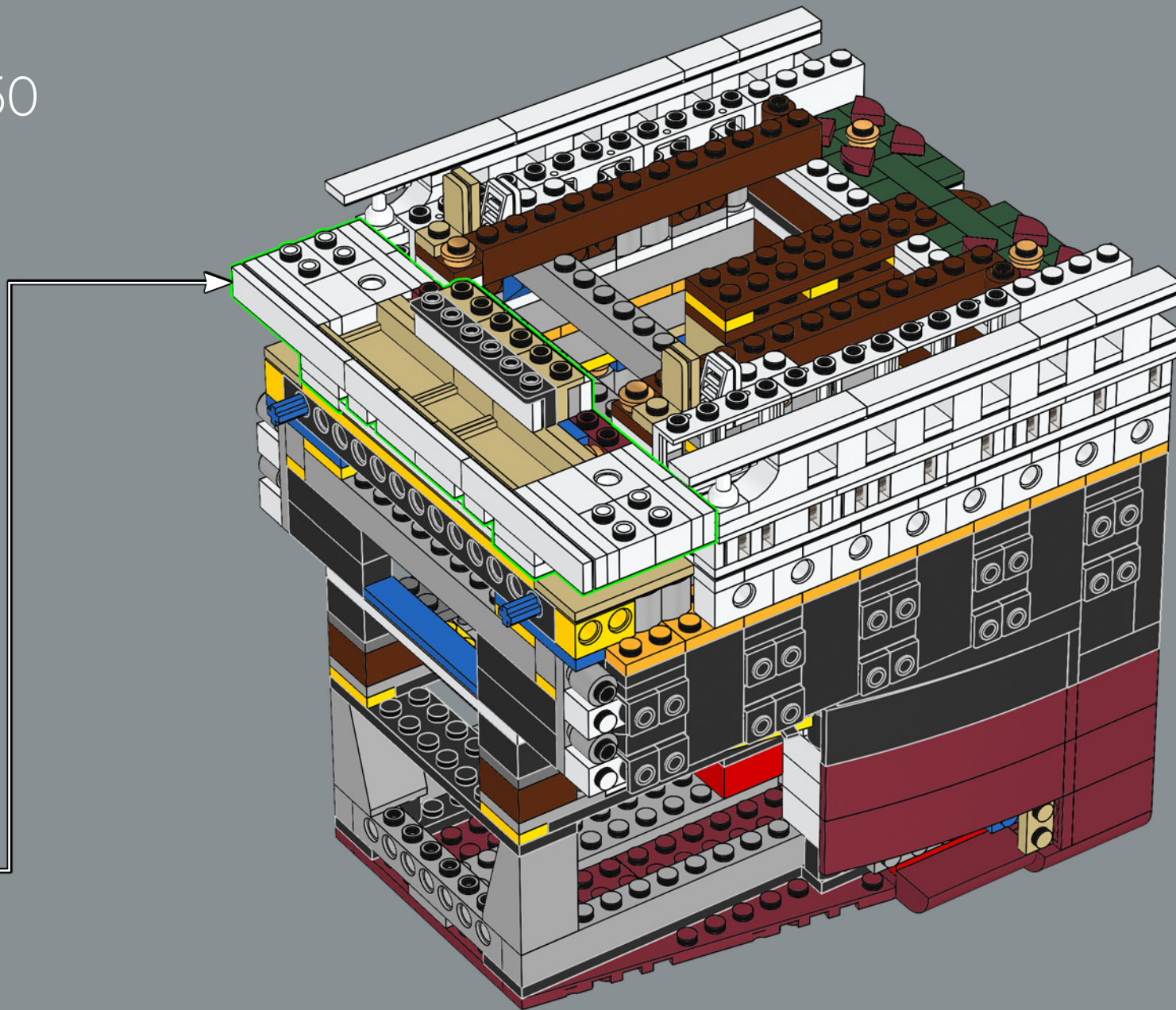

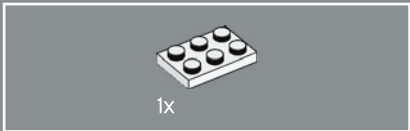
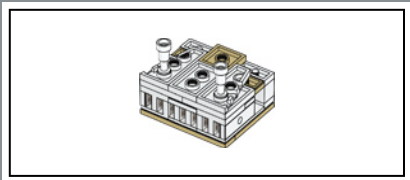

251

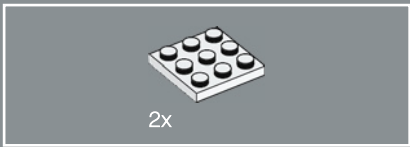

252

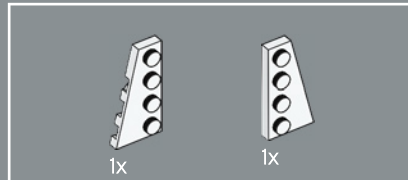
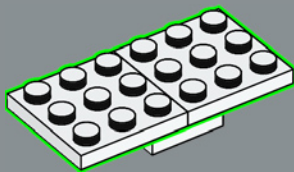

253

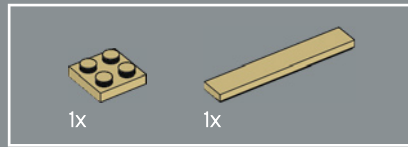
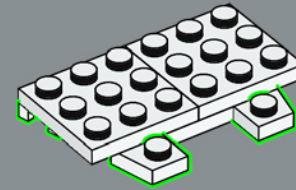

254

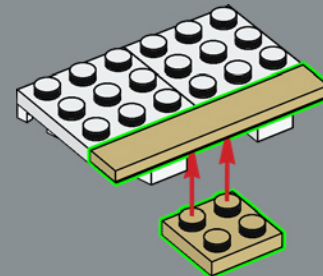

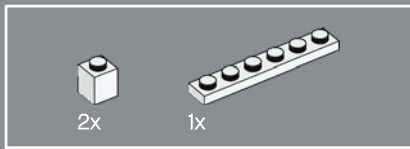

255

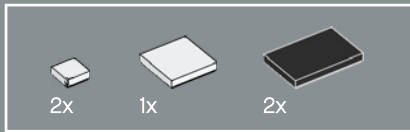
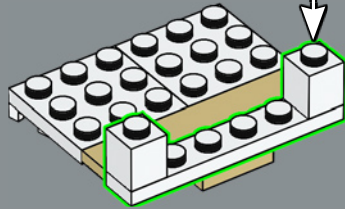
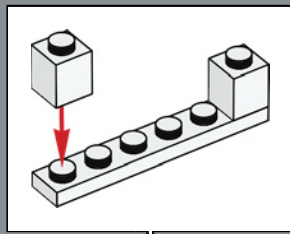

256

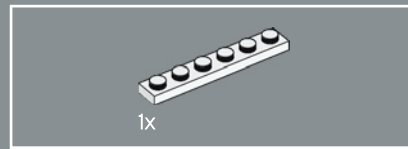
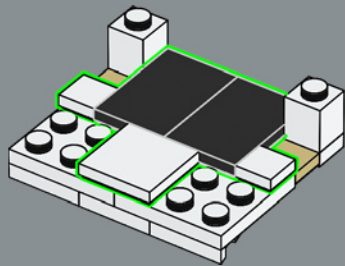

257

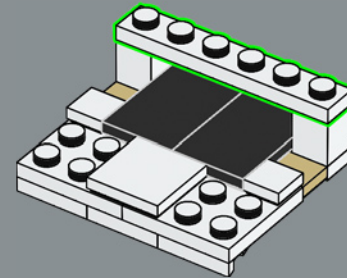

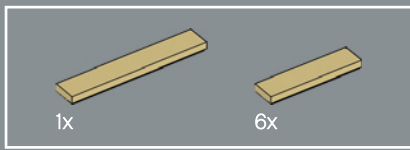

259

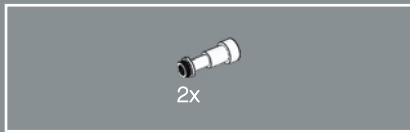
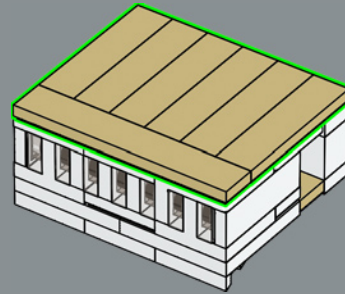

260

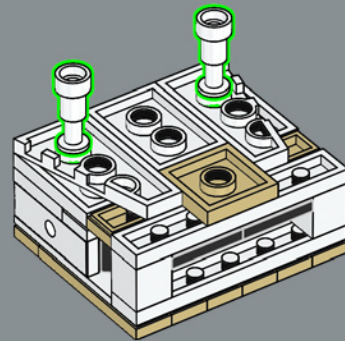

Il ponte di comando si trovava 2,4 metri sopra la coperta e si estendeva su entrambi i lati in modo che la nave potesse essere controllata durante l'attracco.

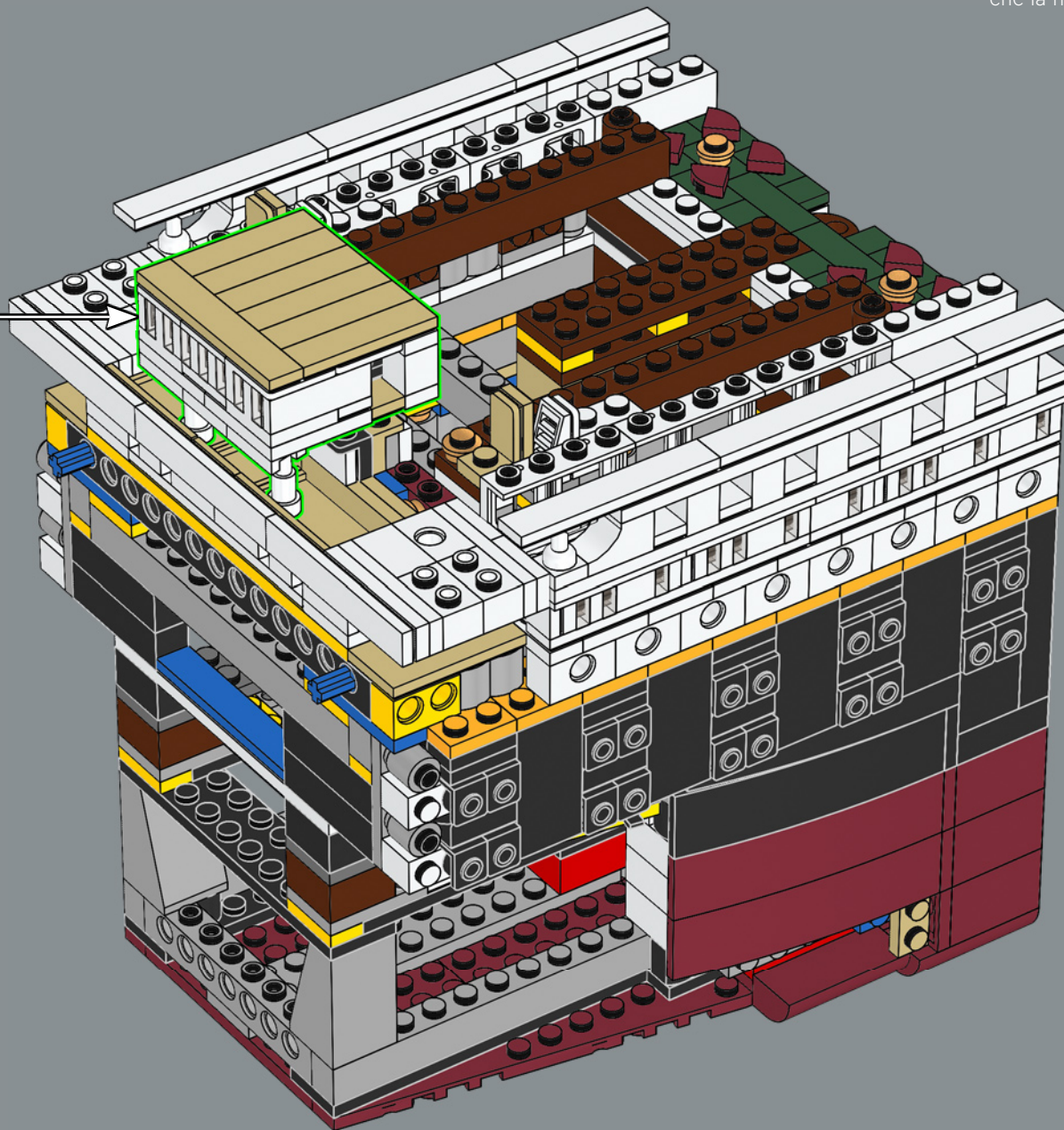



262

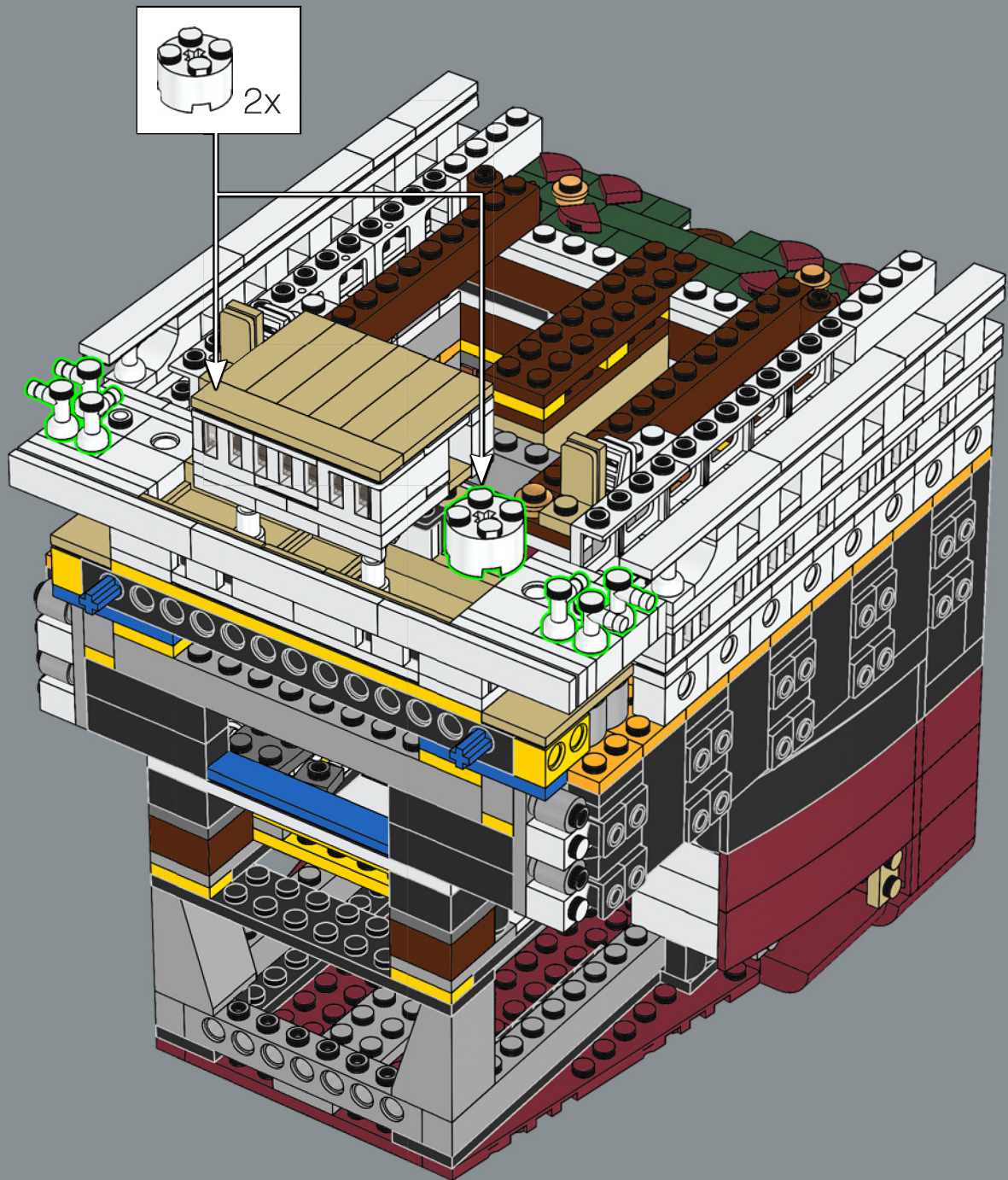

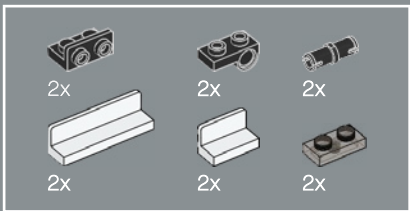

263

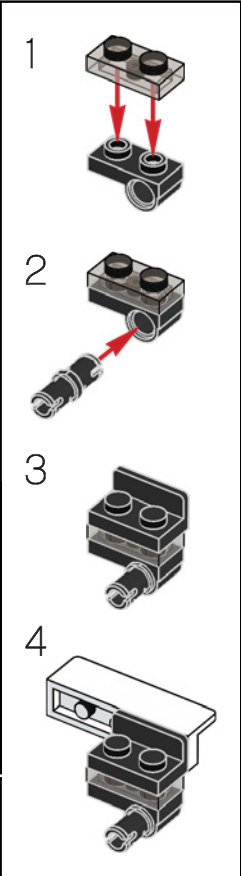
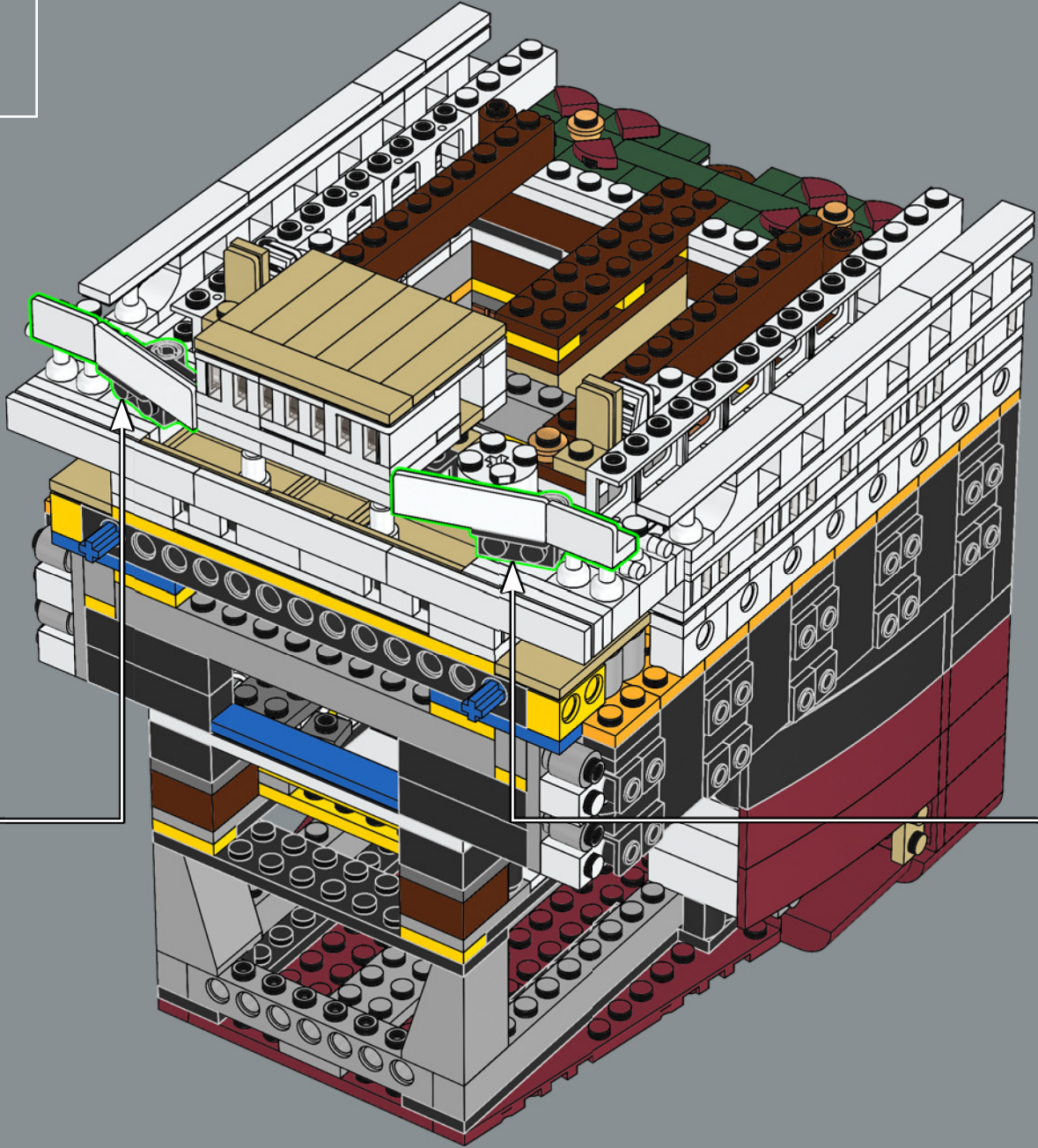
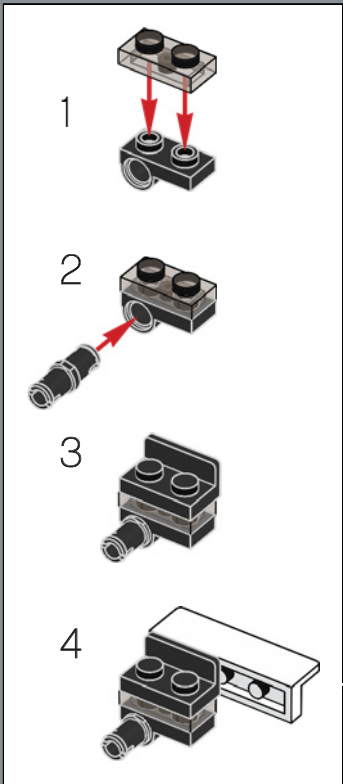

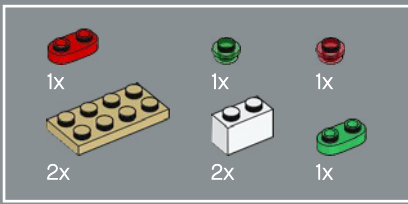

264

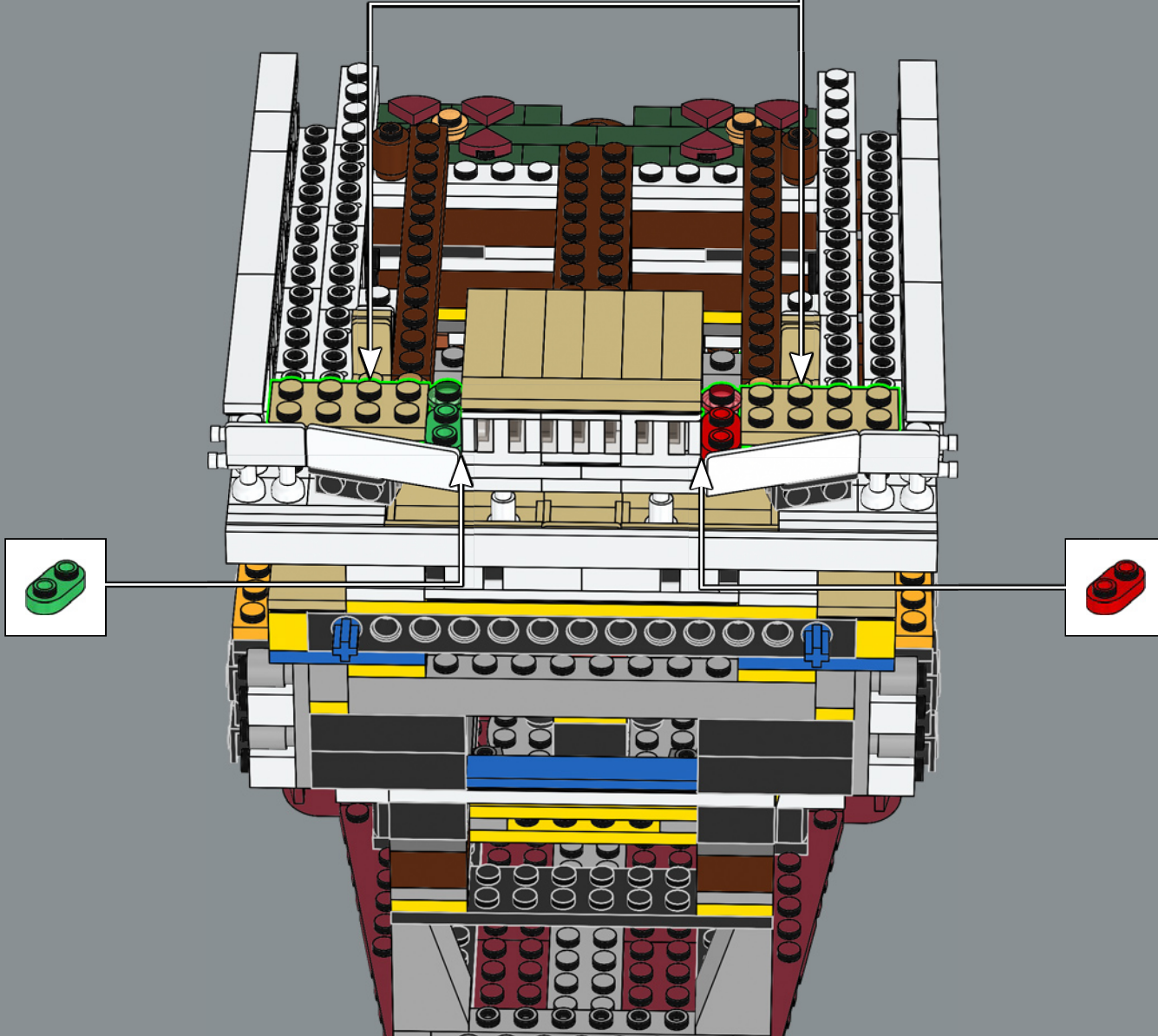
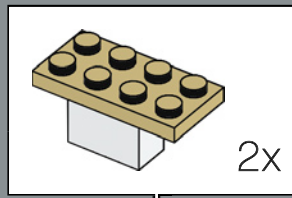

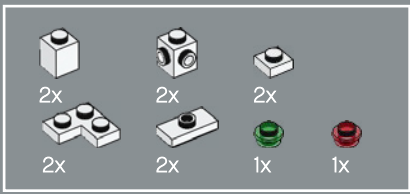

265

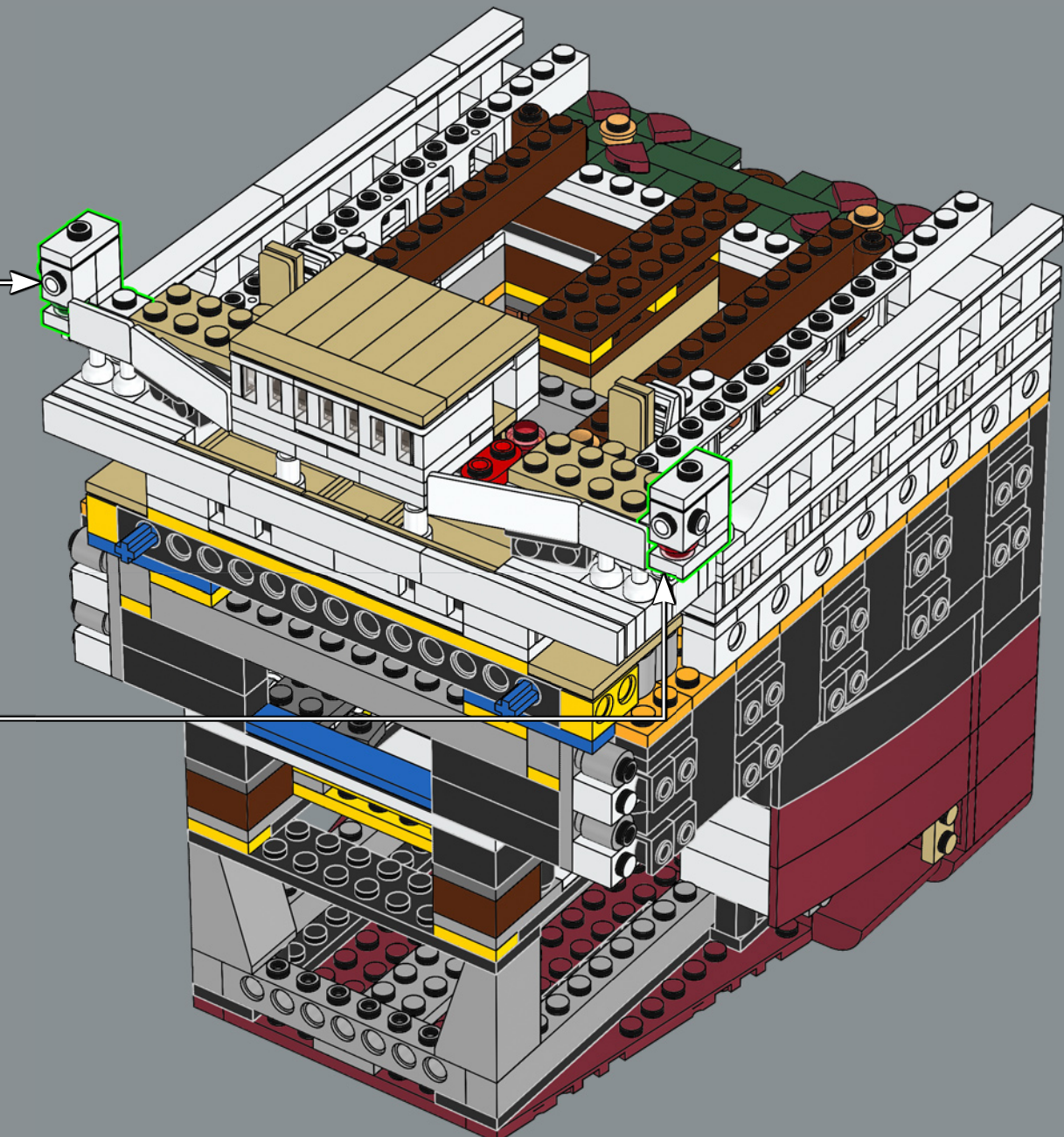
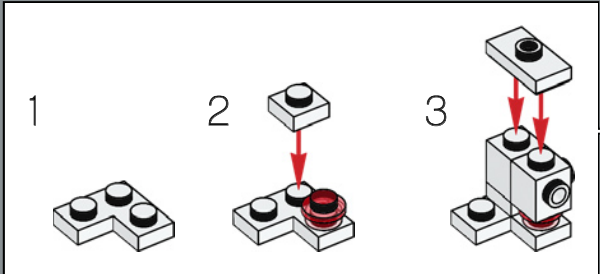
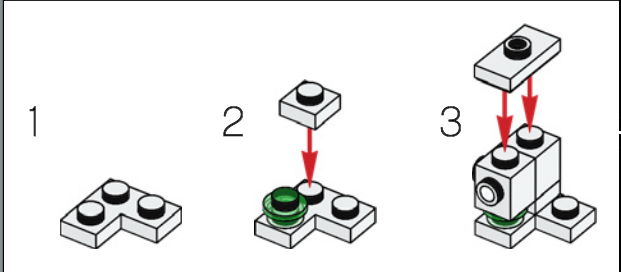

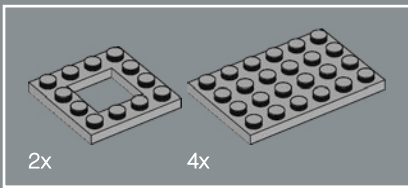

266

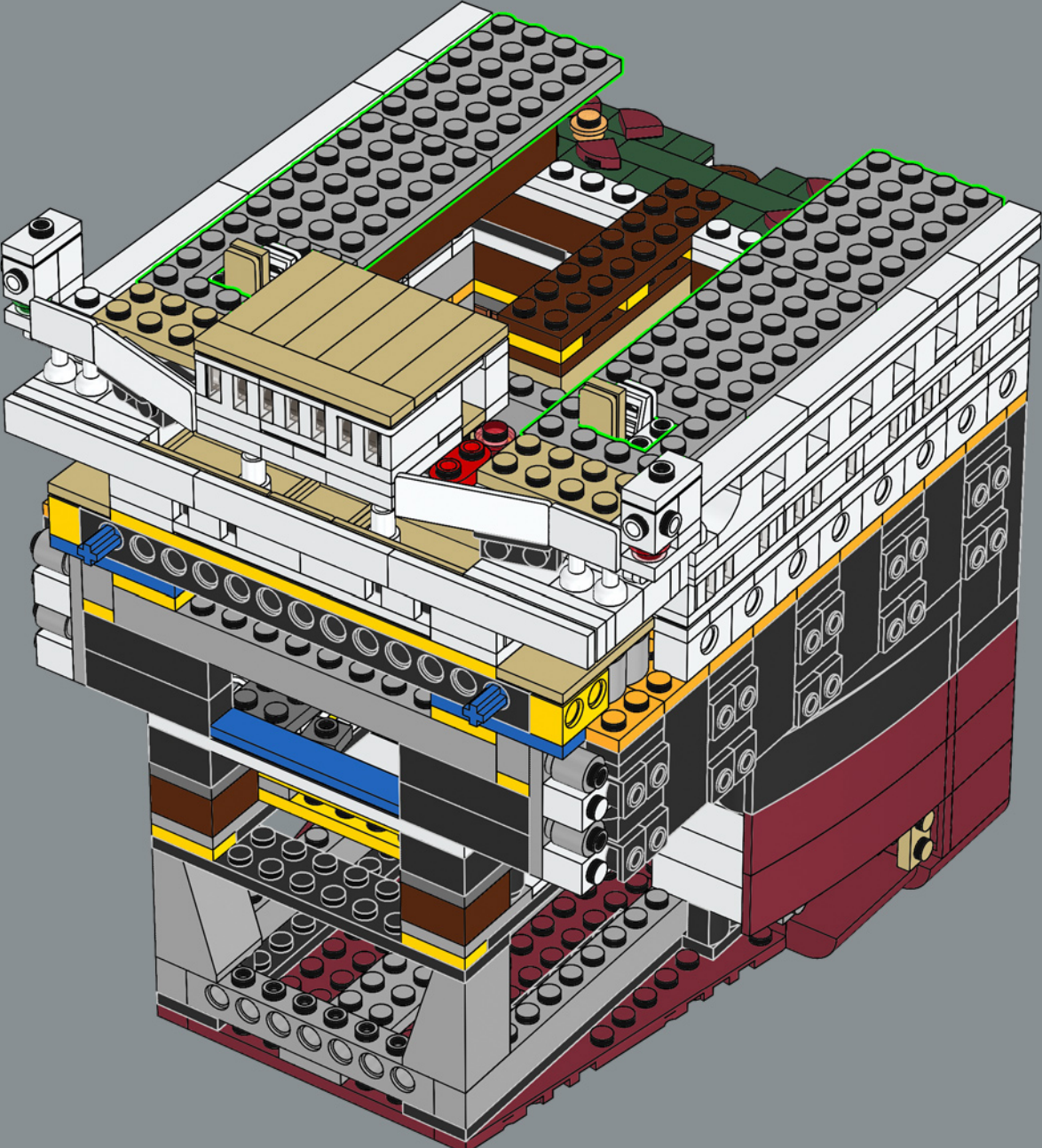

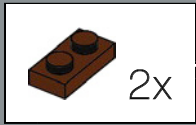
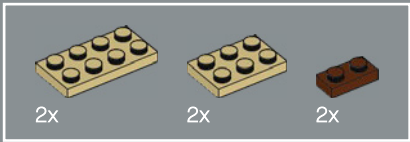

267

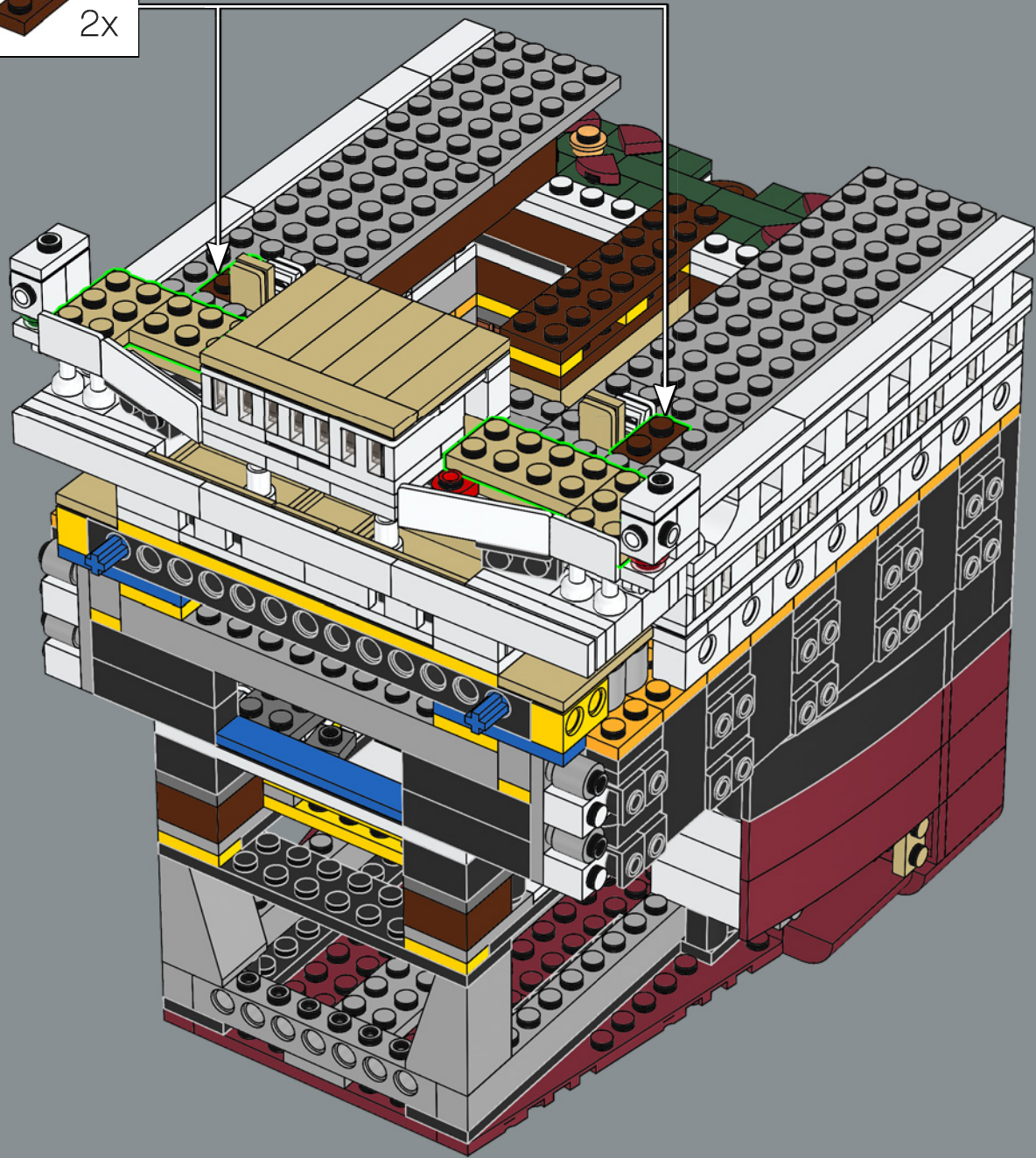

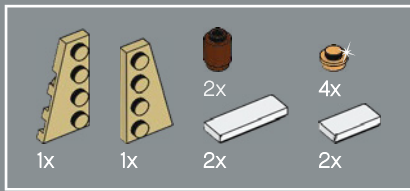

268

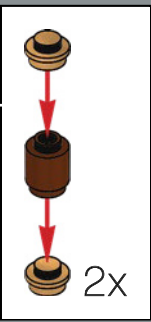
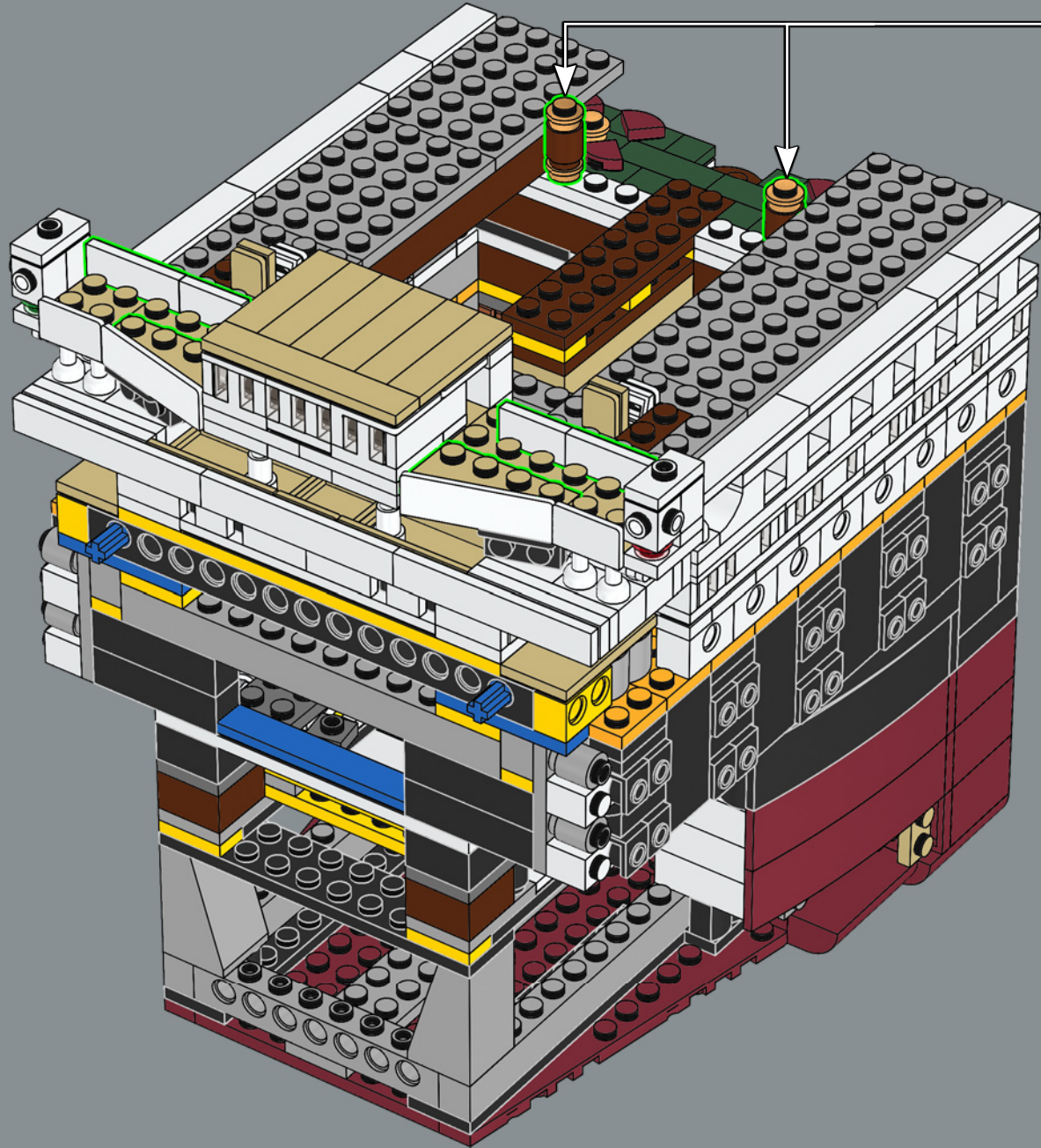
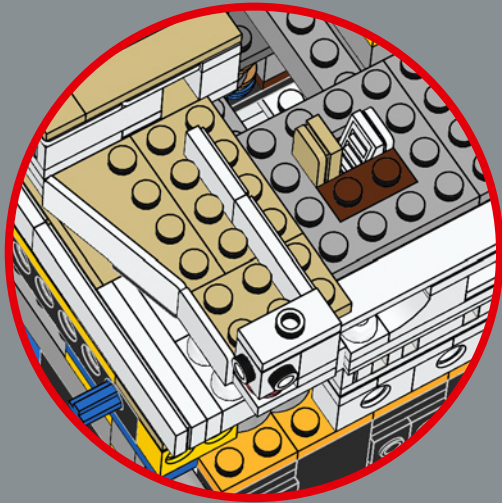
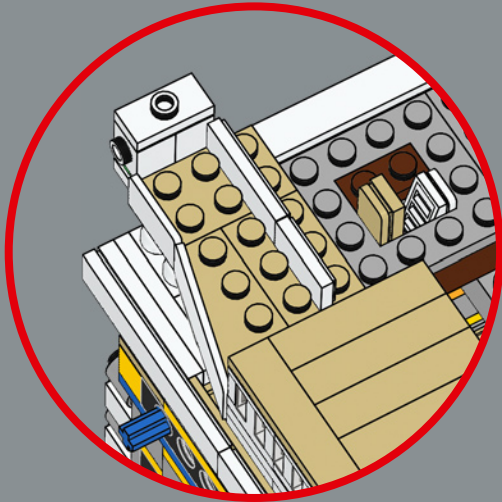

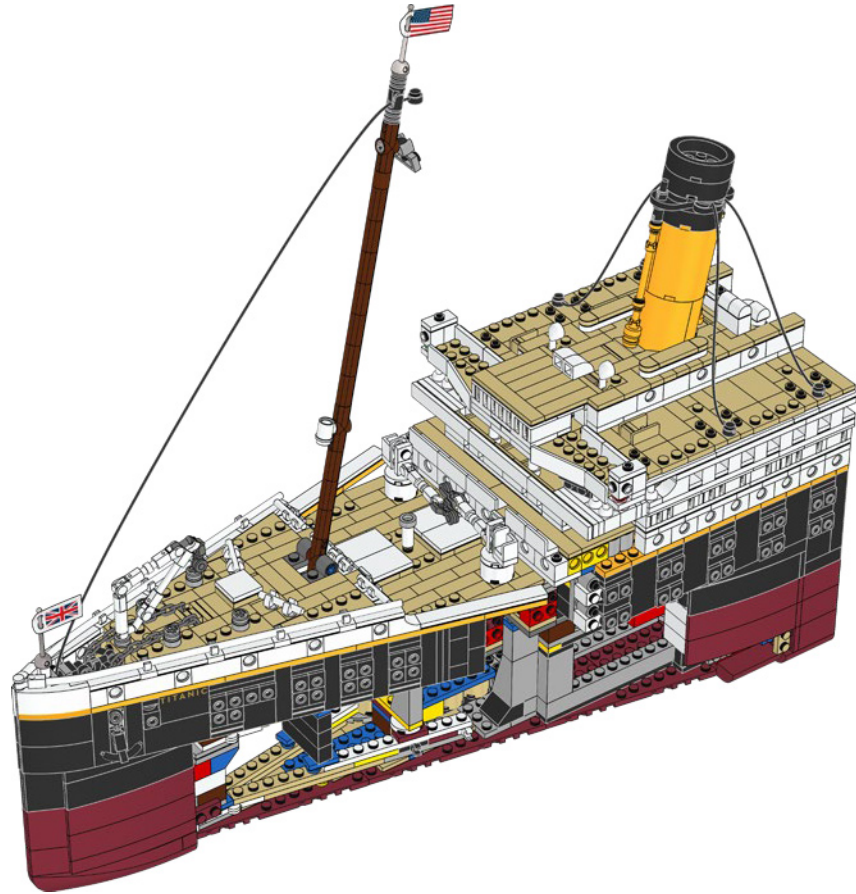

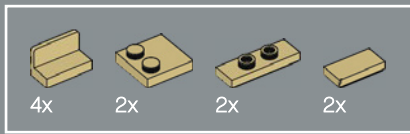

269

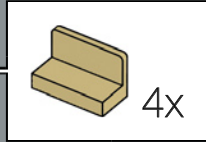
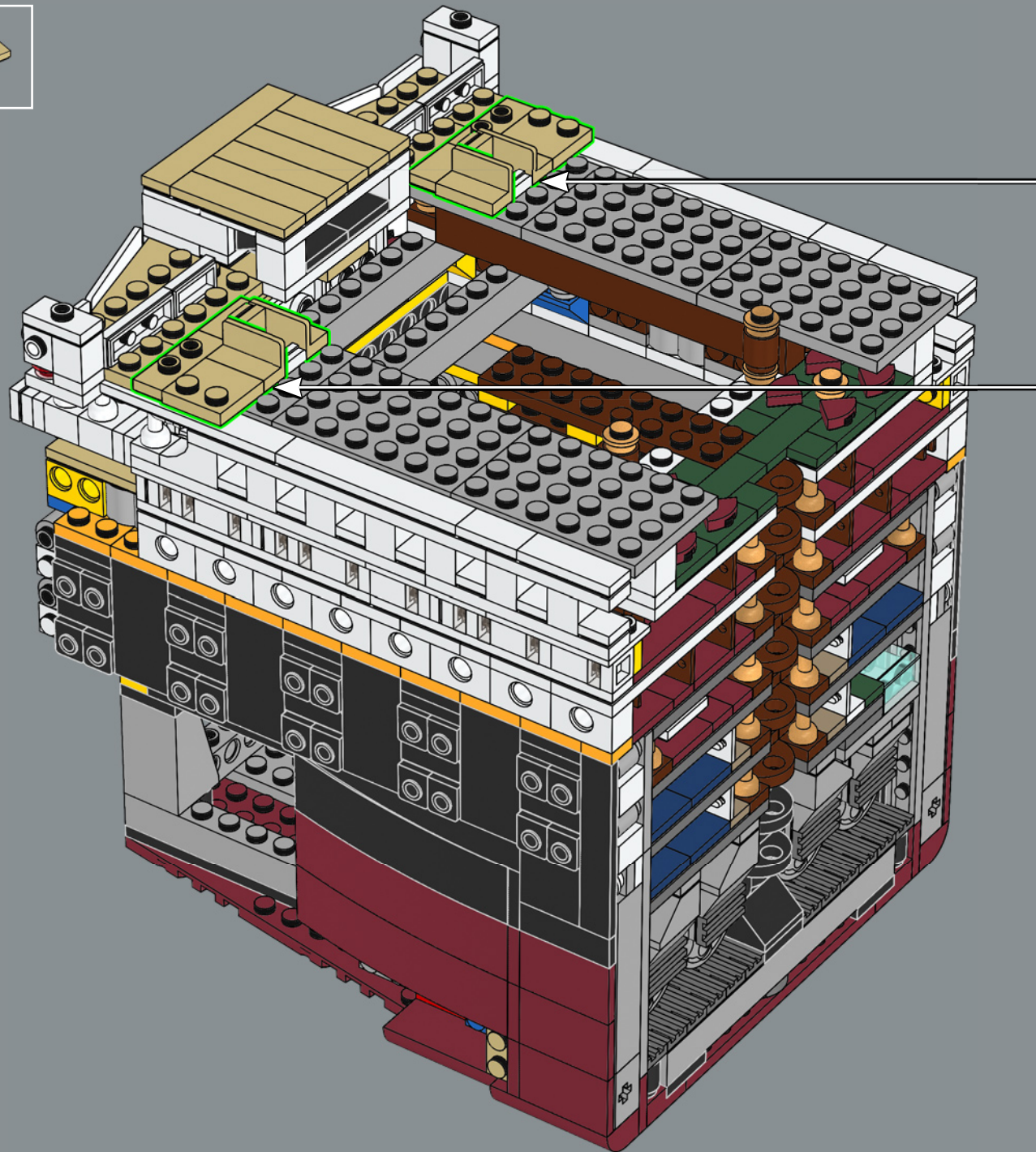

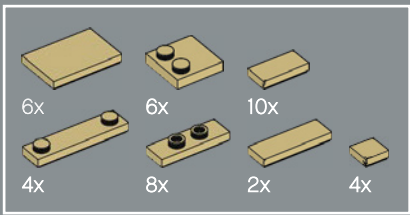

270

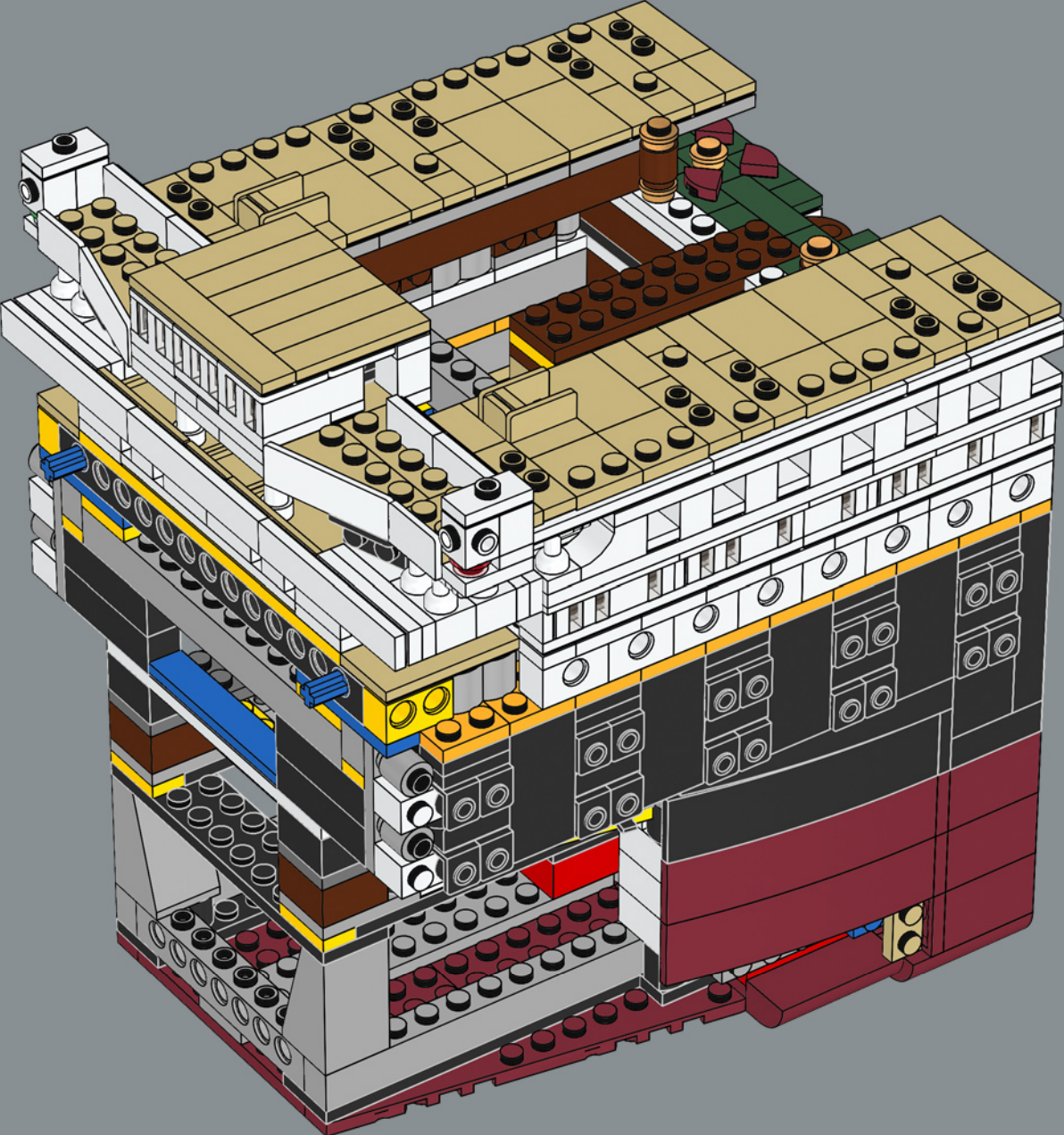

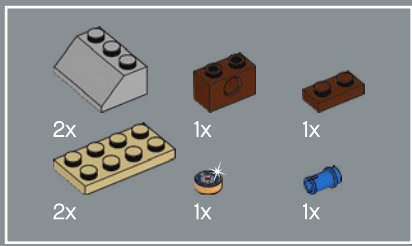

274

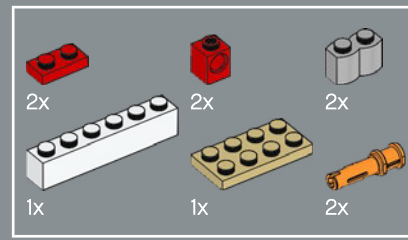
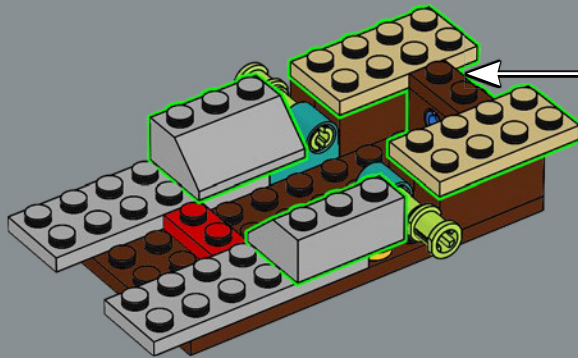
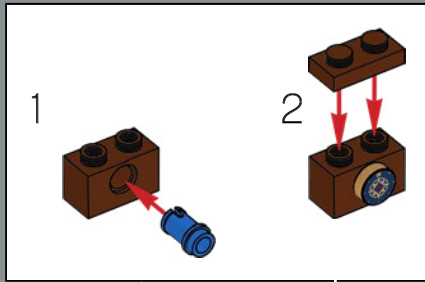

275

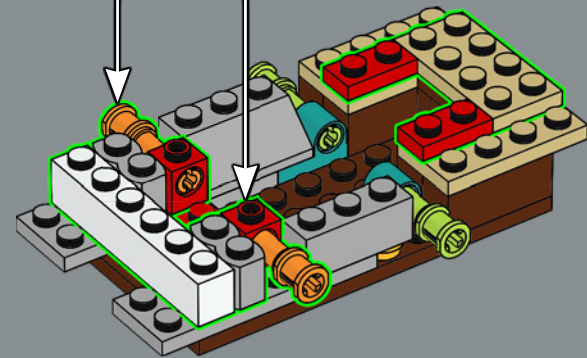
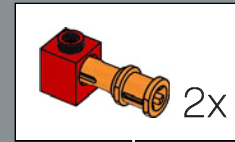

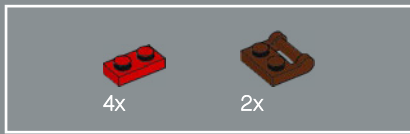

276

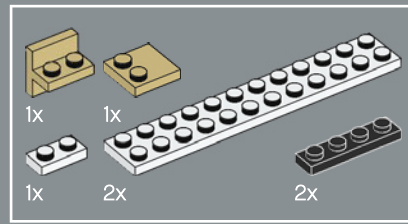
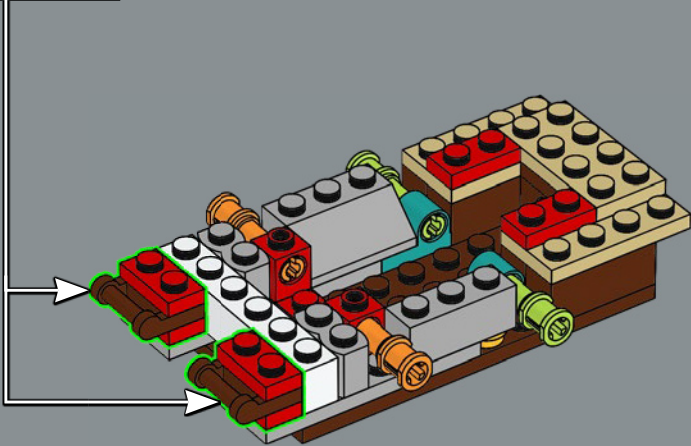
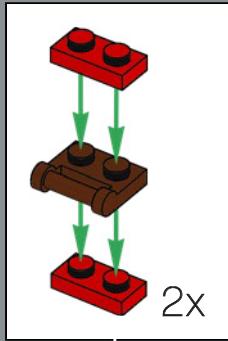

277

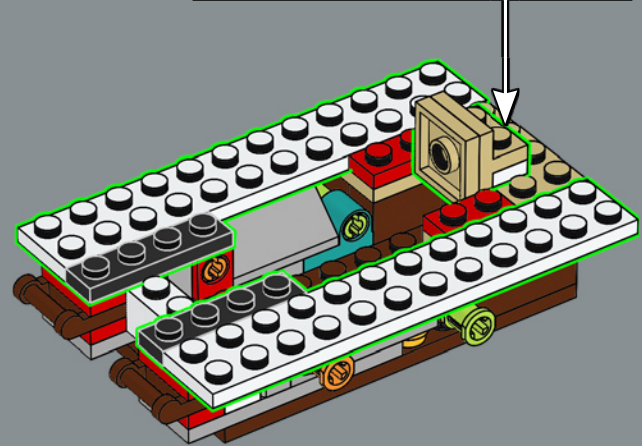
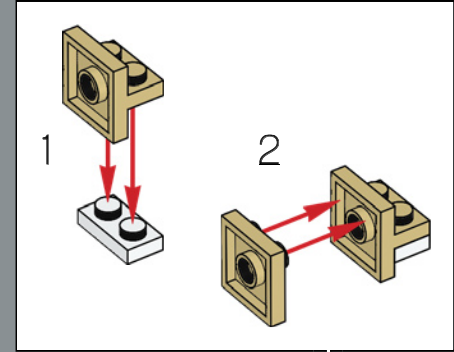

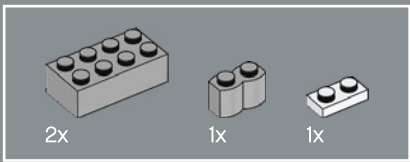

278

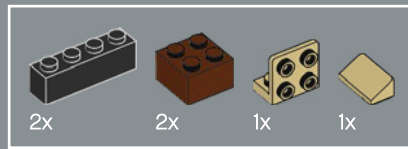
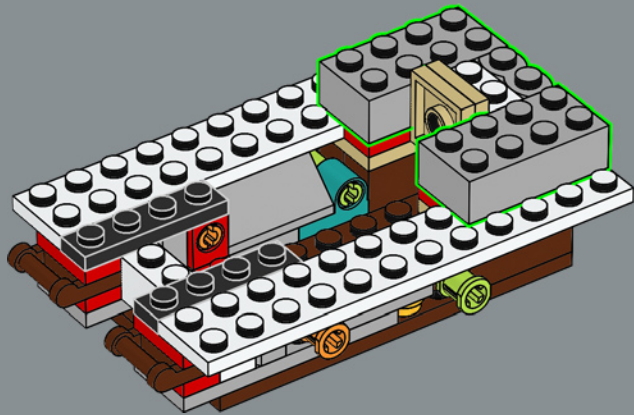

279

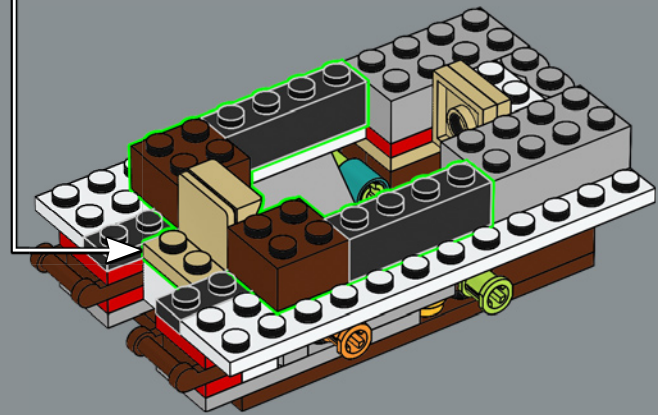
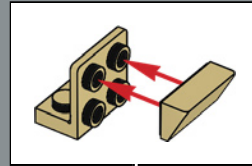

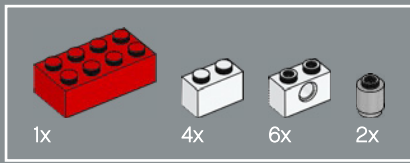

280

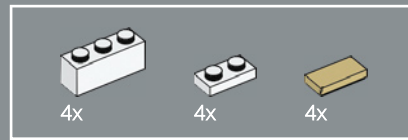
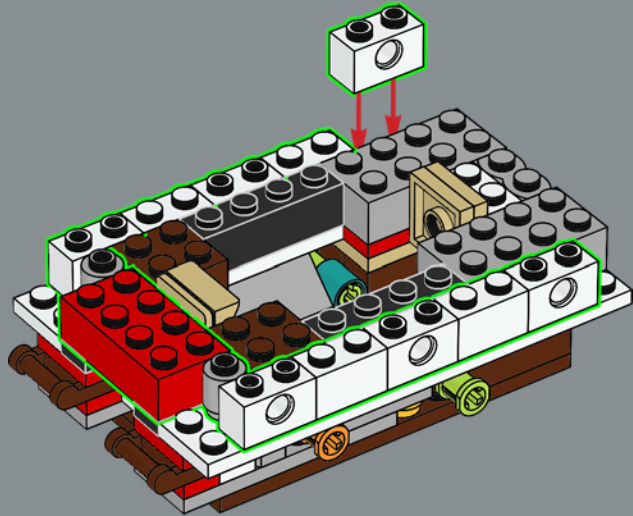

281

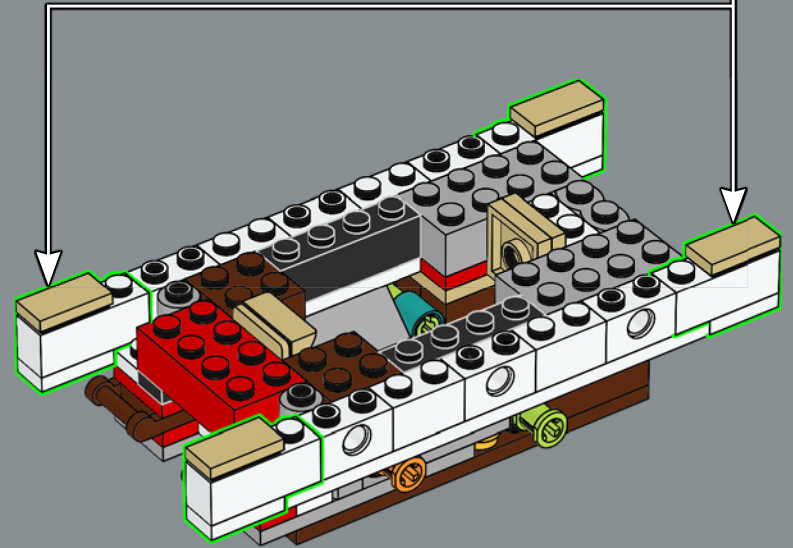
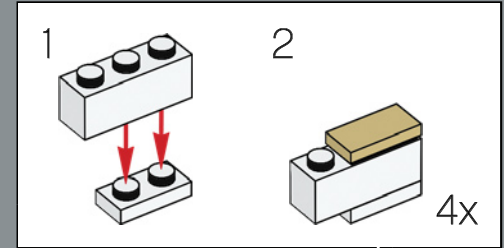

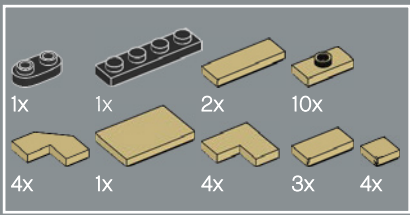

282

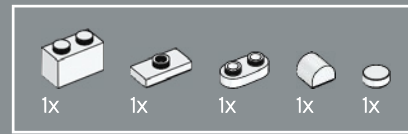
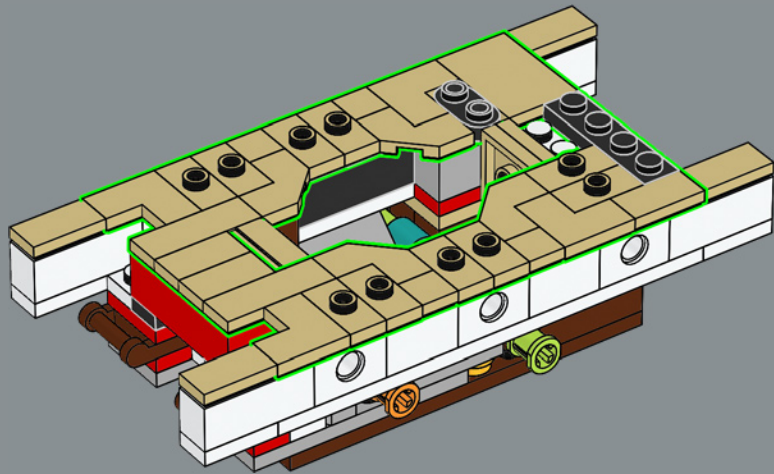

283

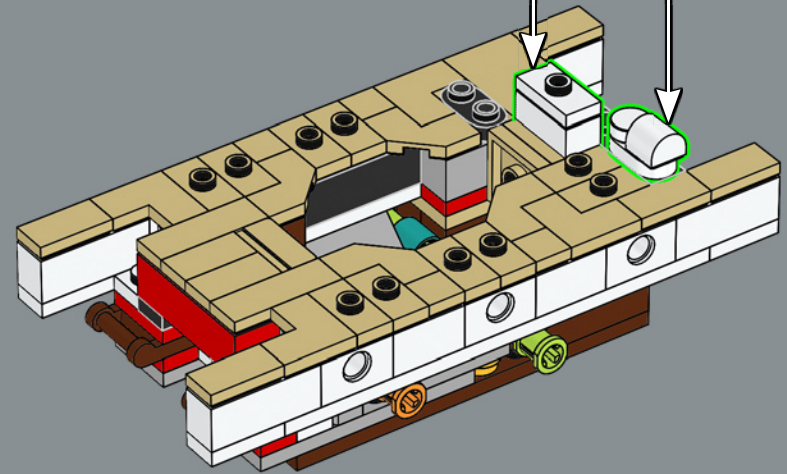
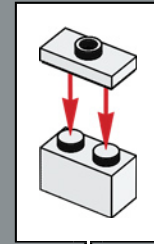
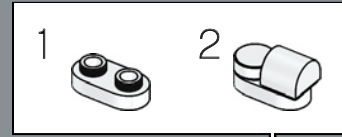

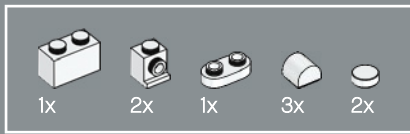

284

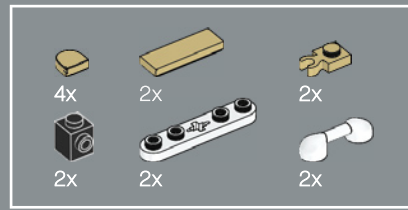
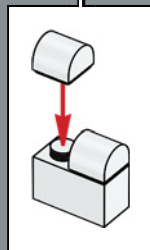
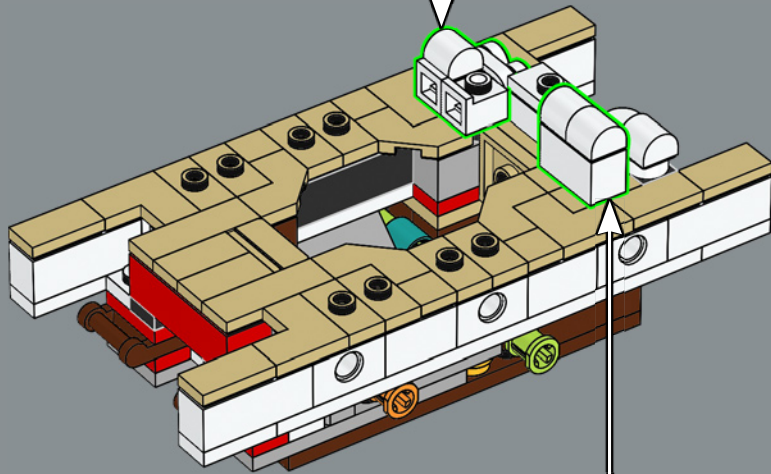
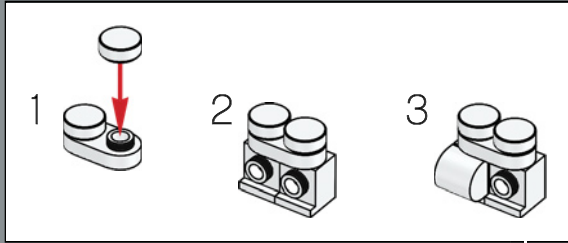

285

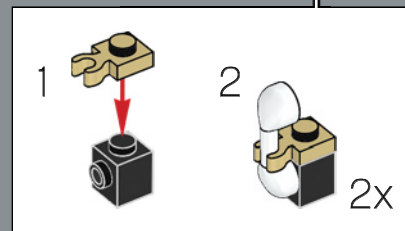
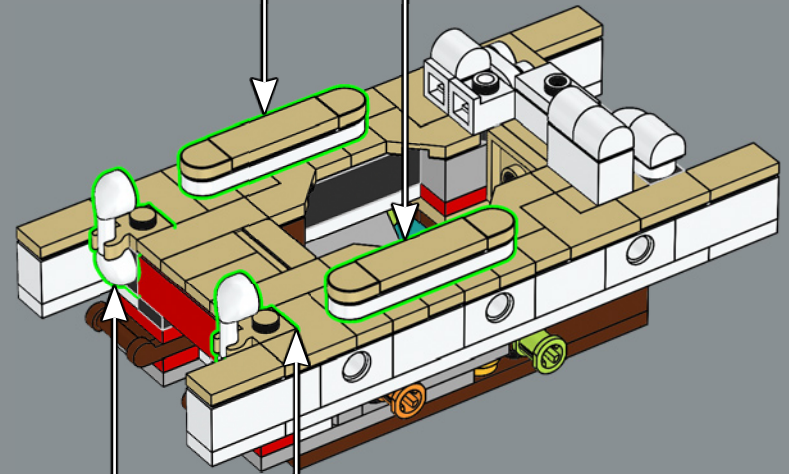
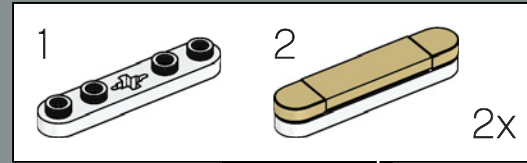

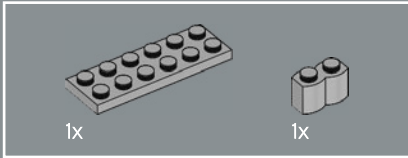
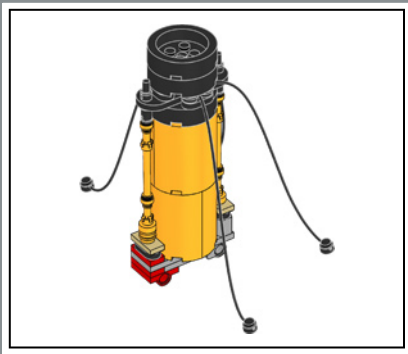

286

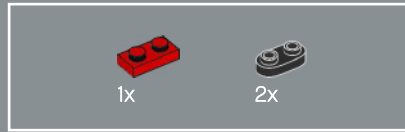
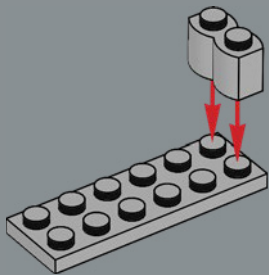

287

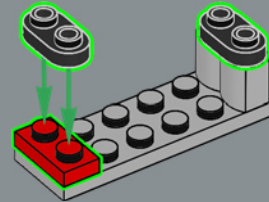

288

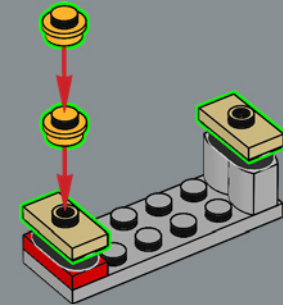

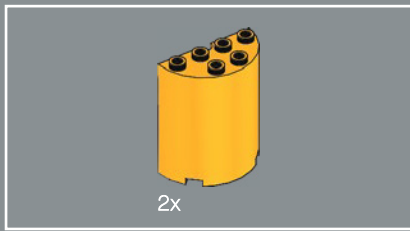

289

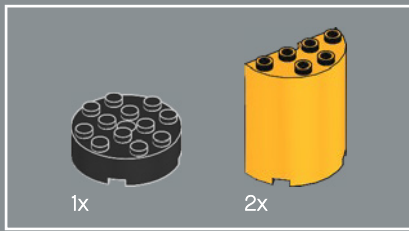
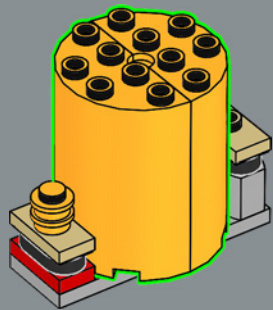

290

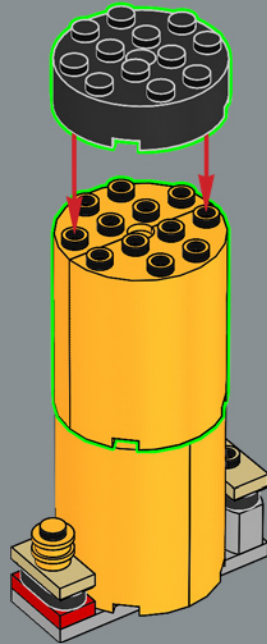

291

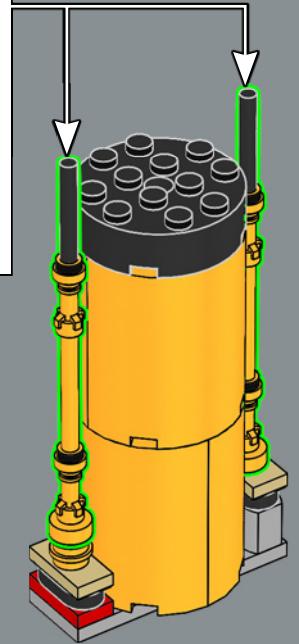
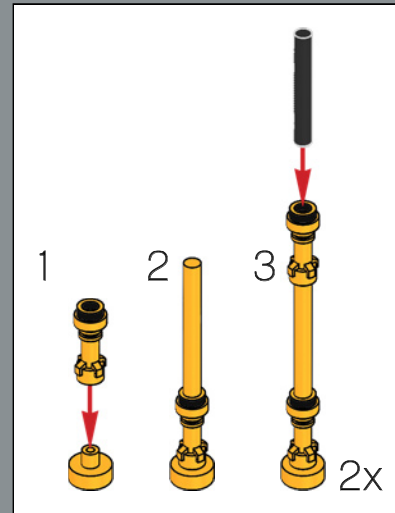

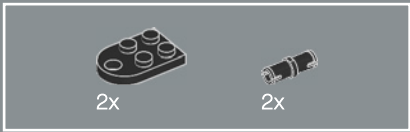

292

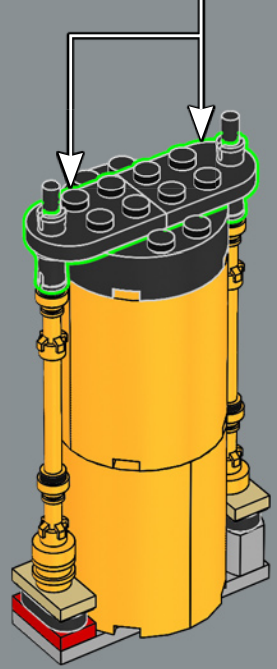
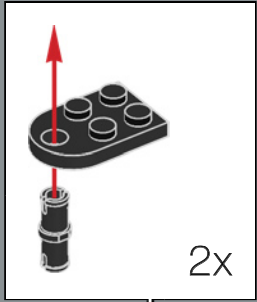

293

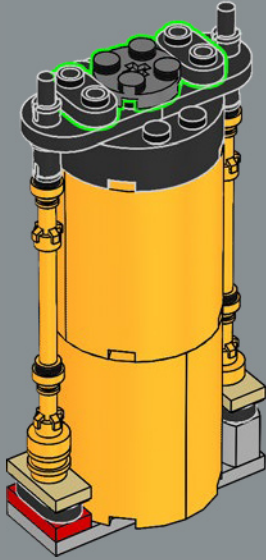

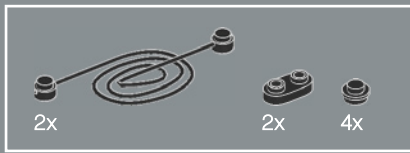

294

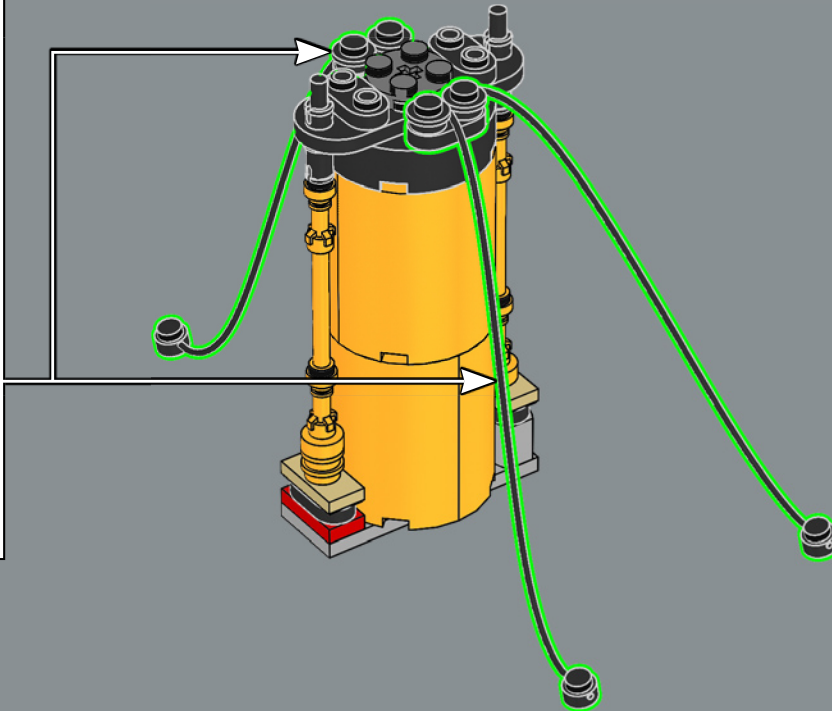
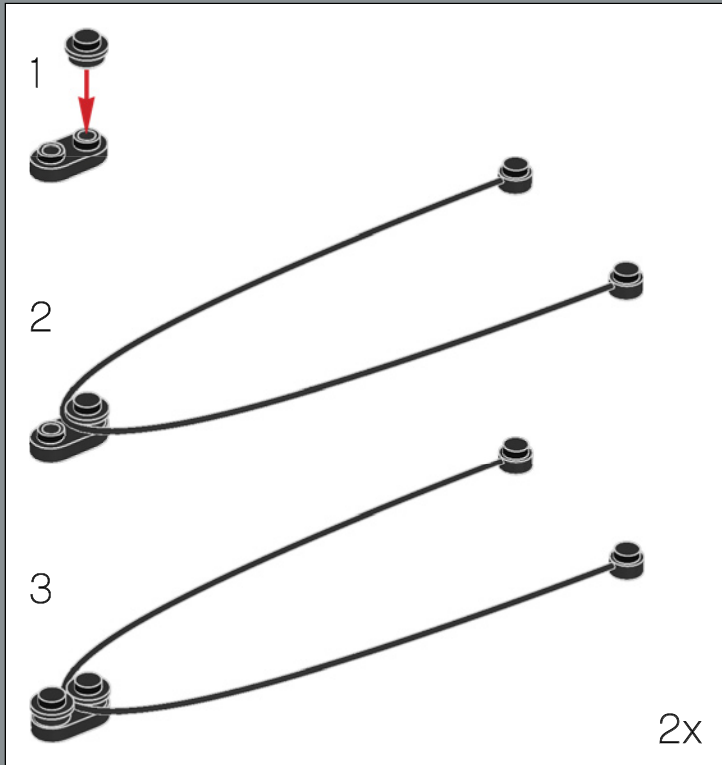

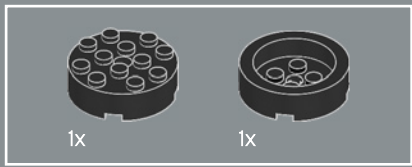

295

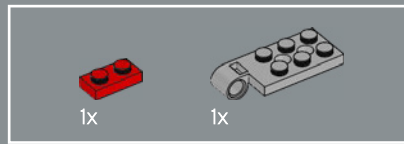
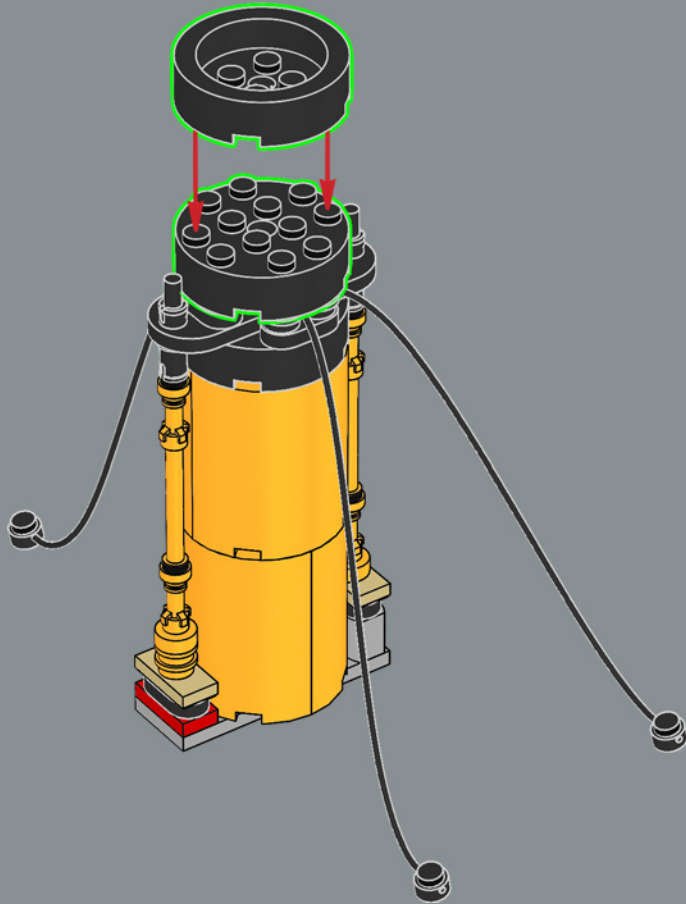

296

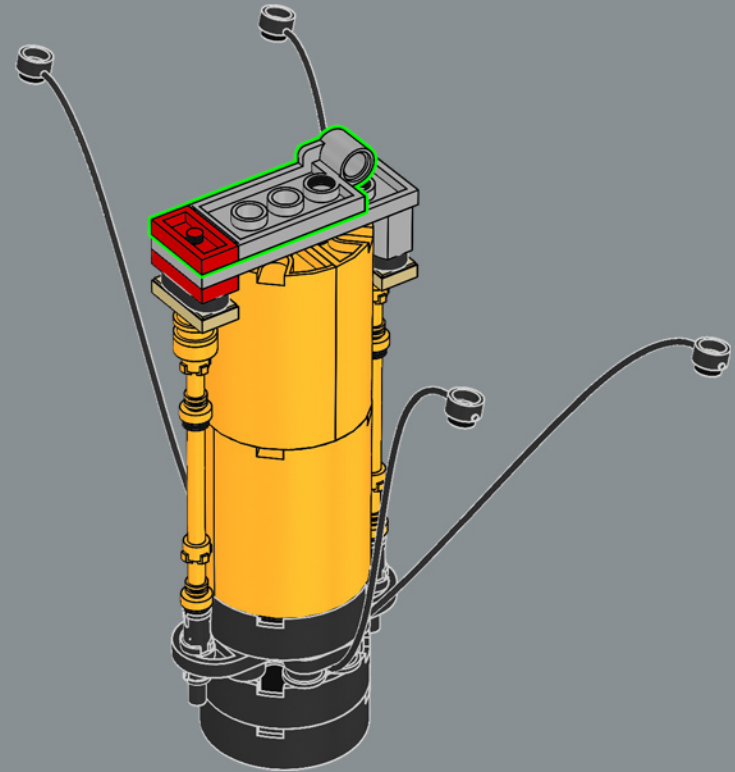

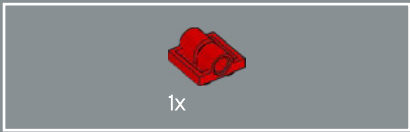

297

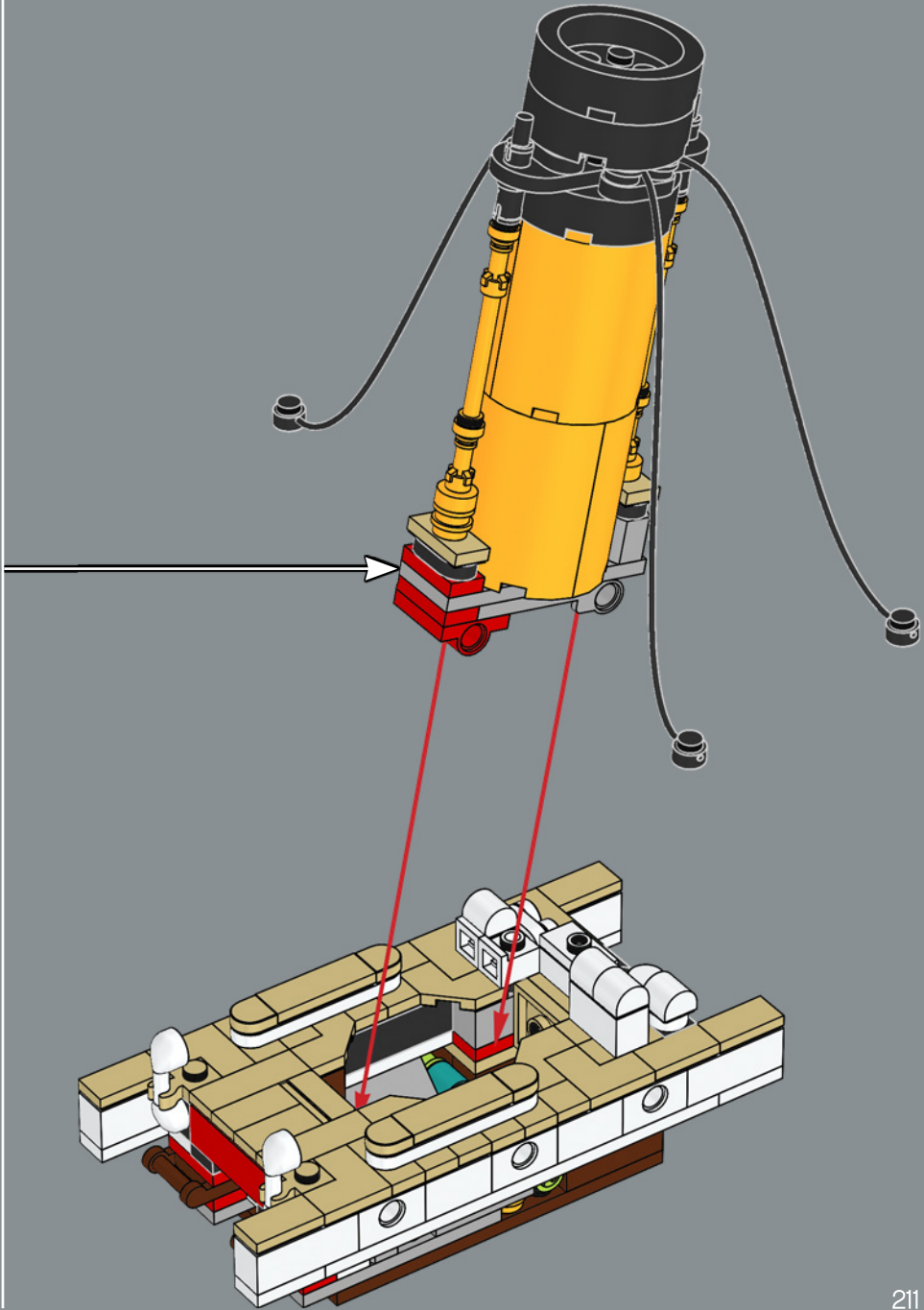
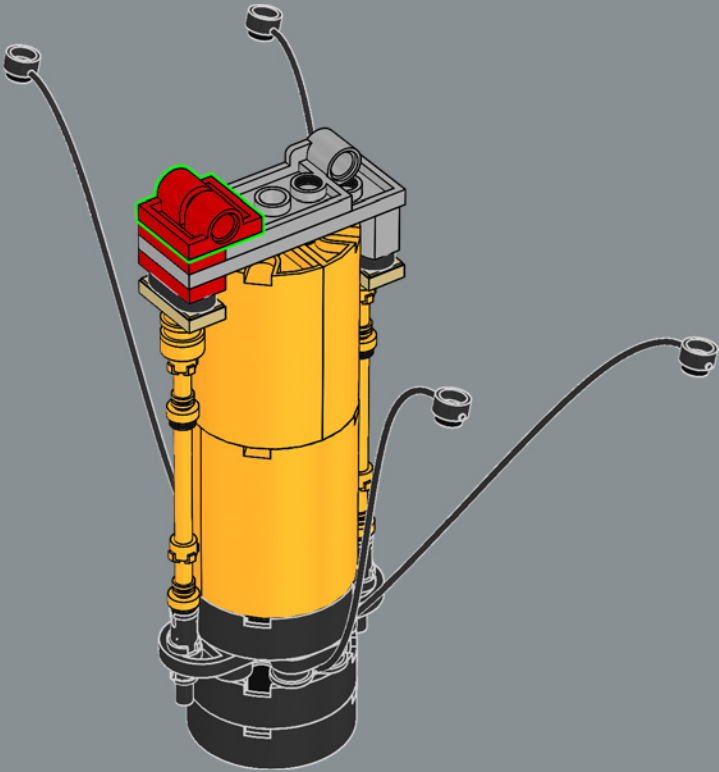

La sala radio della nave era dotata di uno dei trasmettitori più potenti al mondo, in grado di coprire una distanza di 563 km.

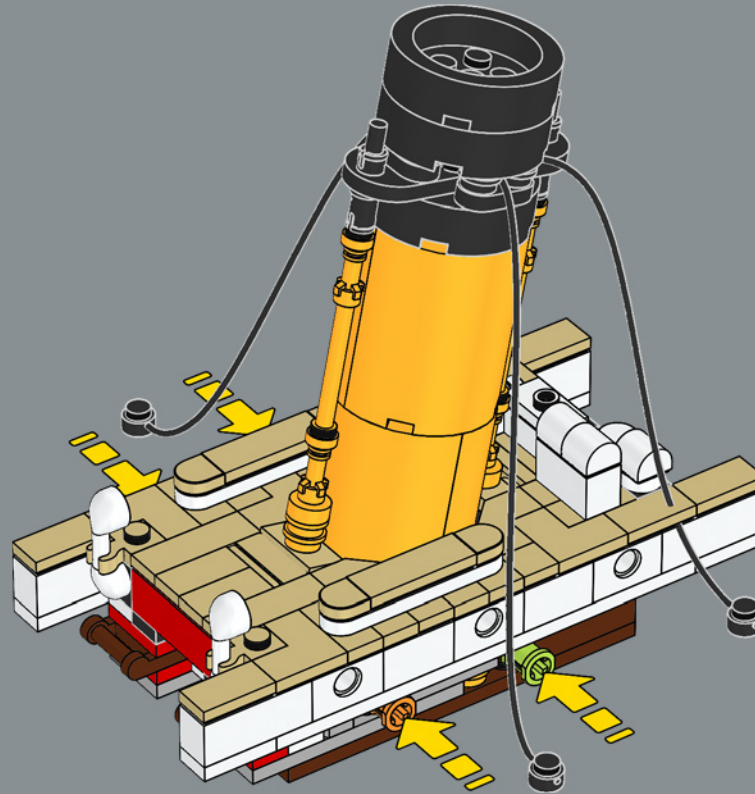

299

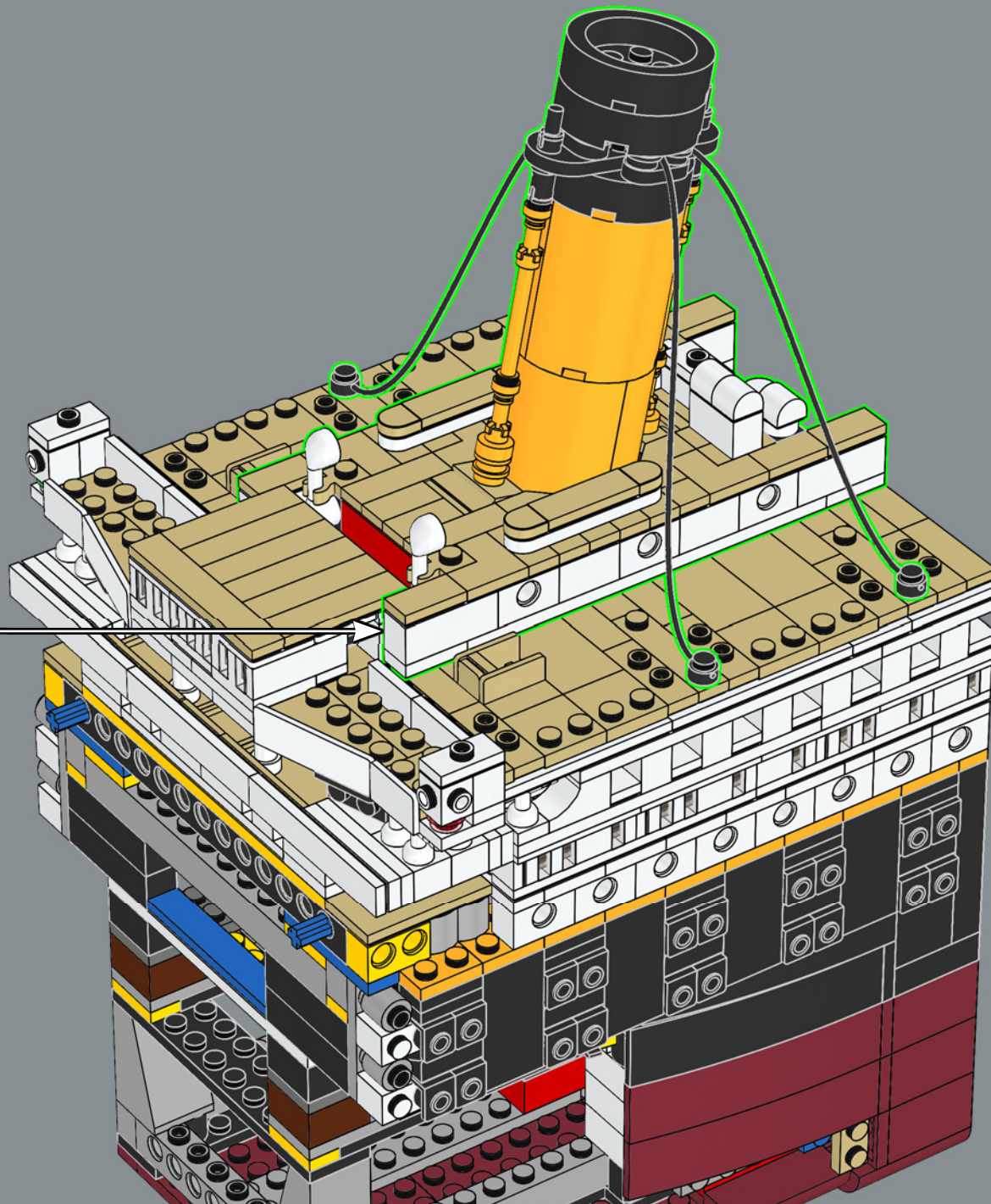

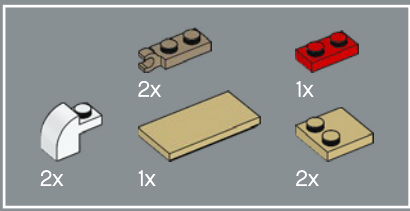

300

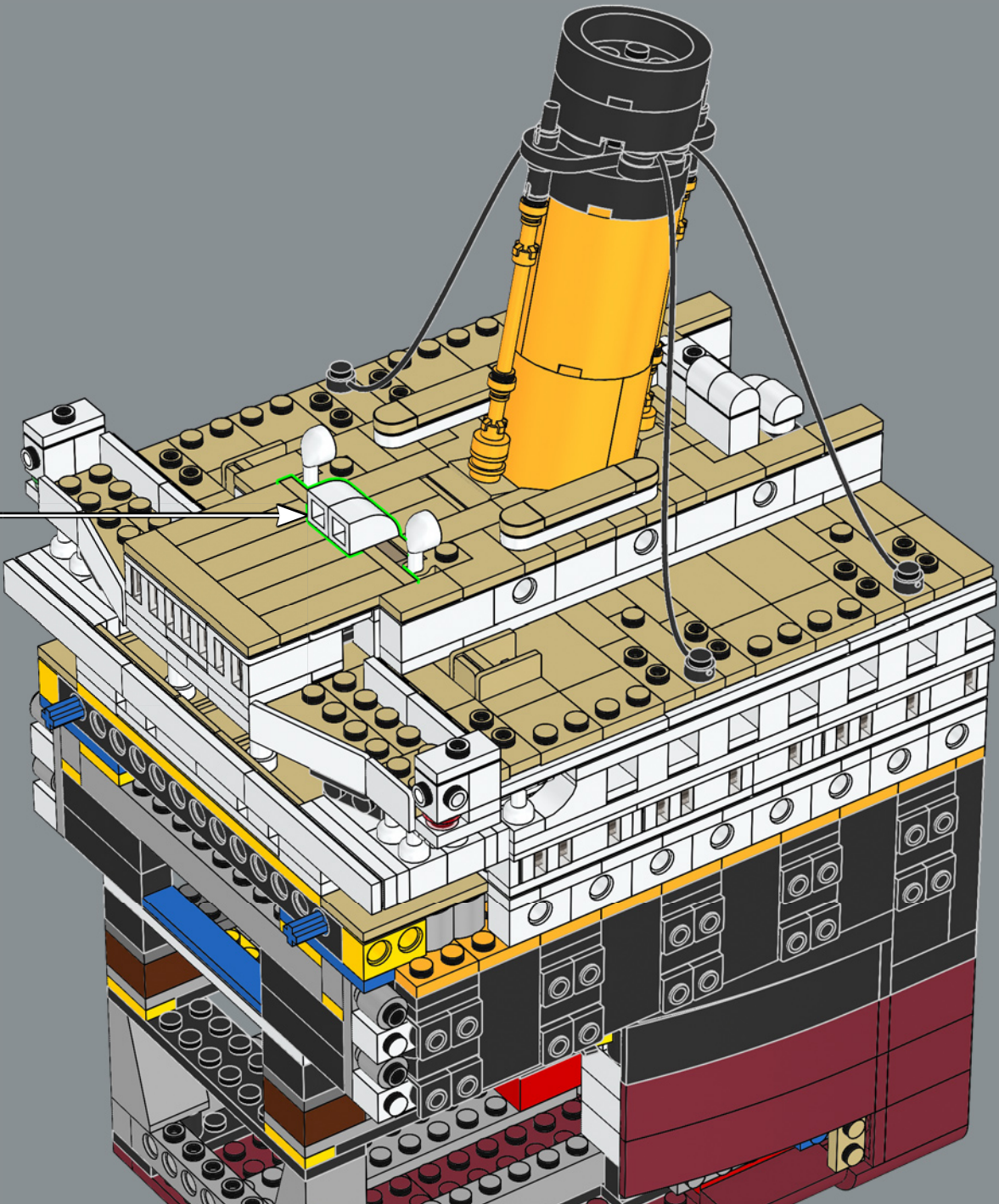
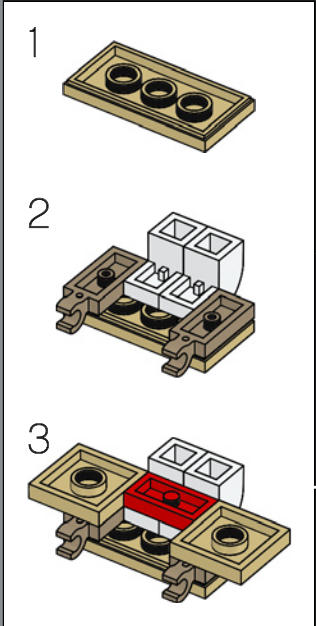

301

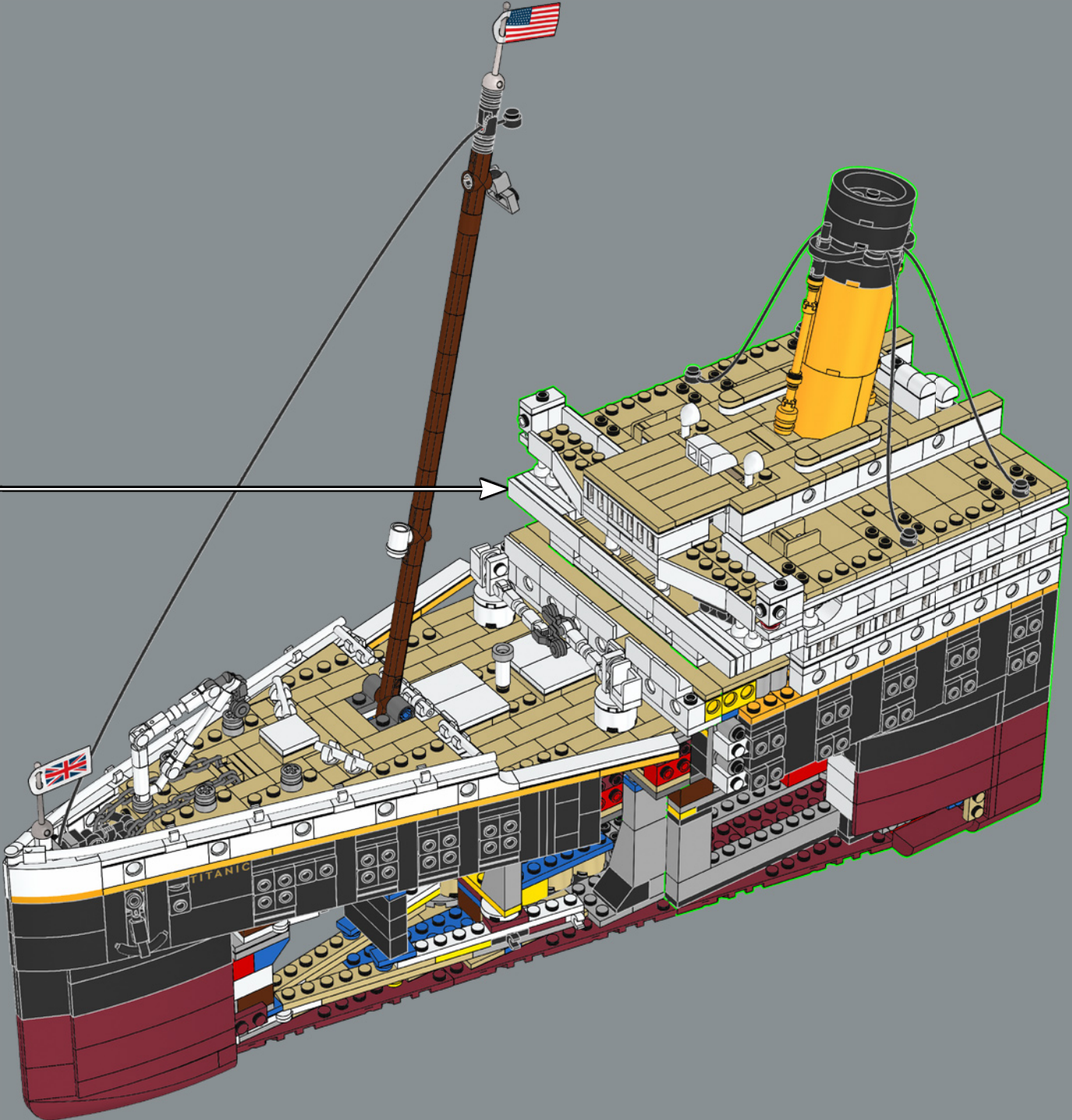

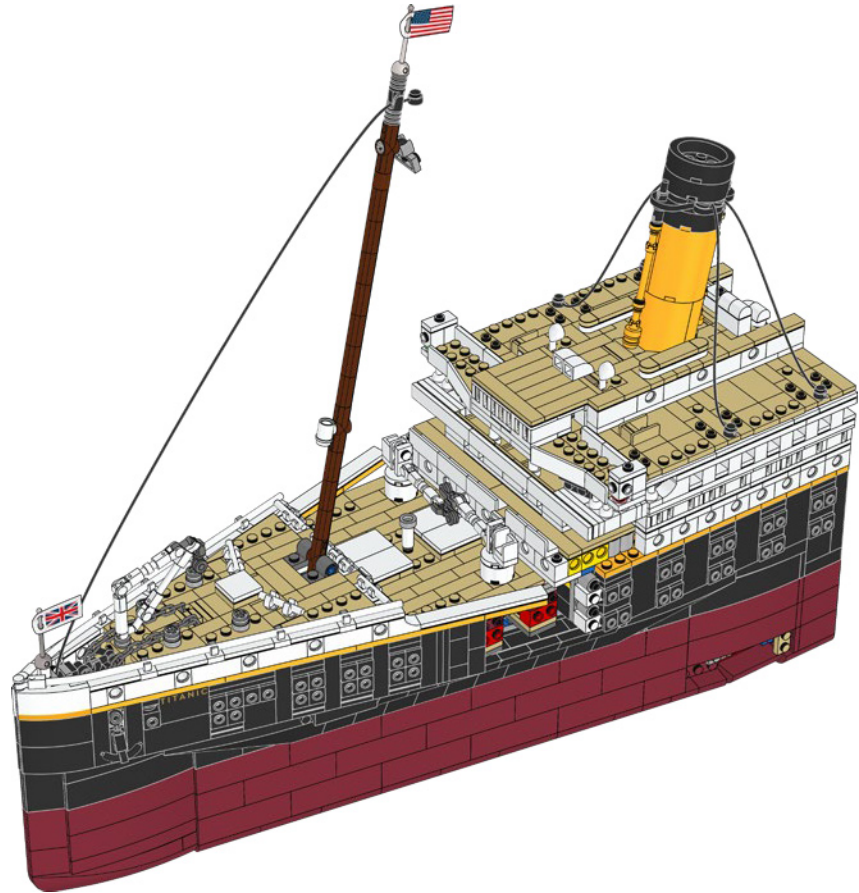
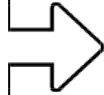

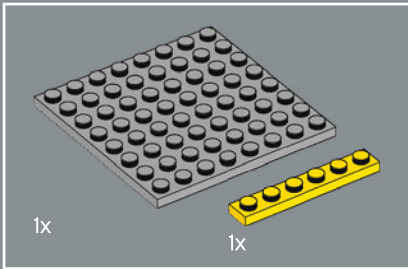
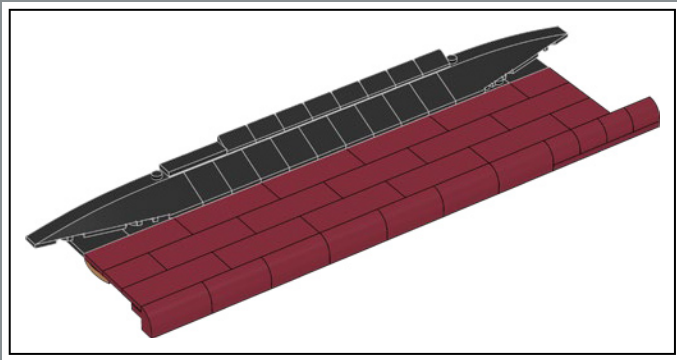

302

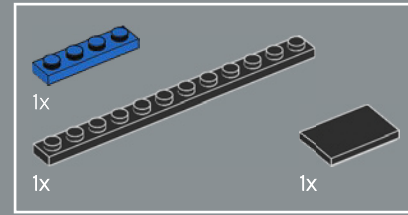
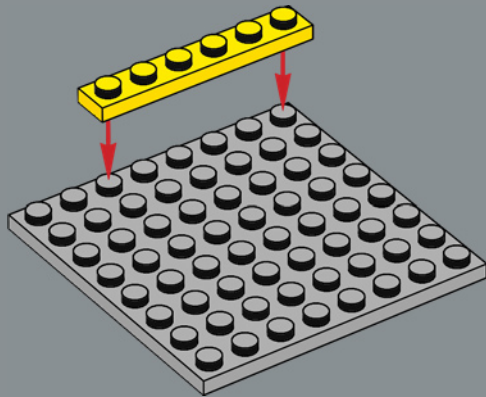

303

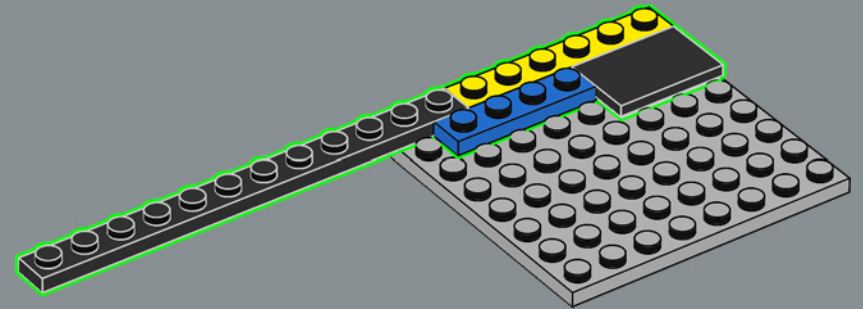

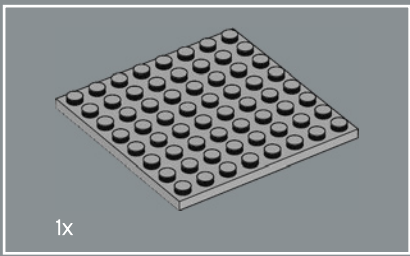

304

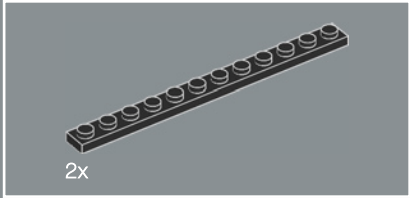
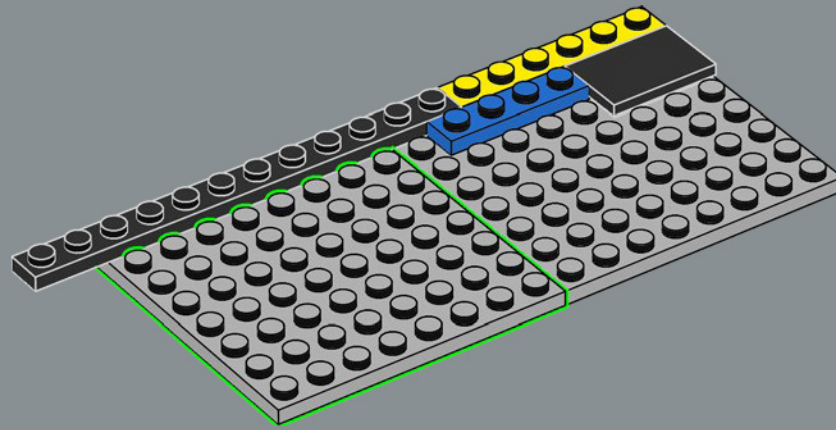

305

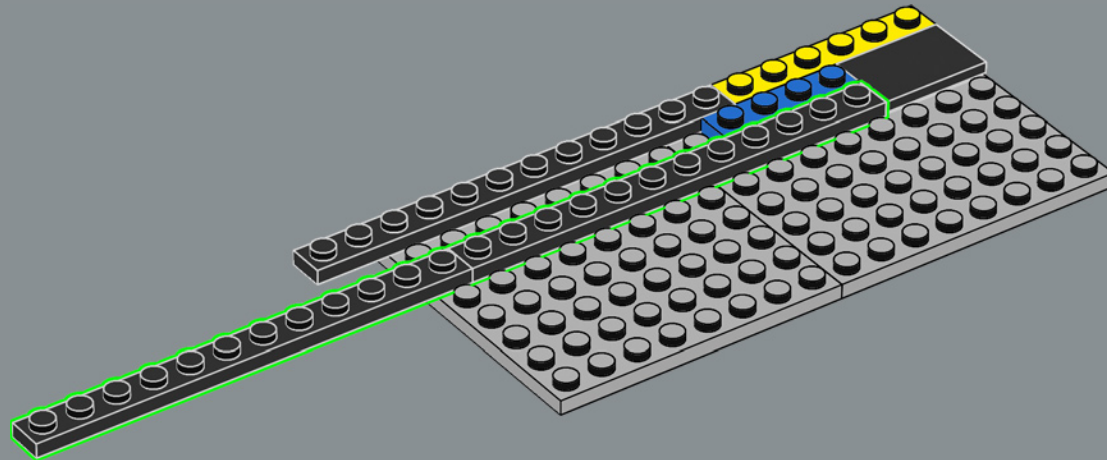

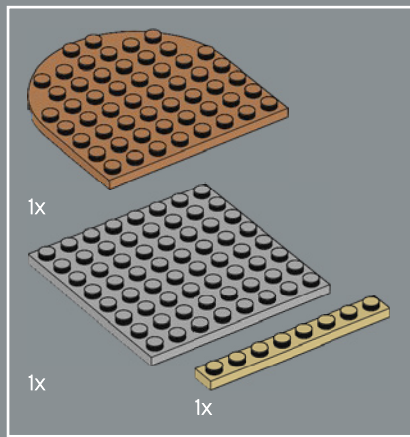

306

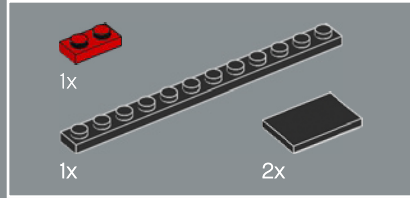
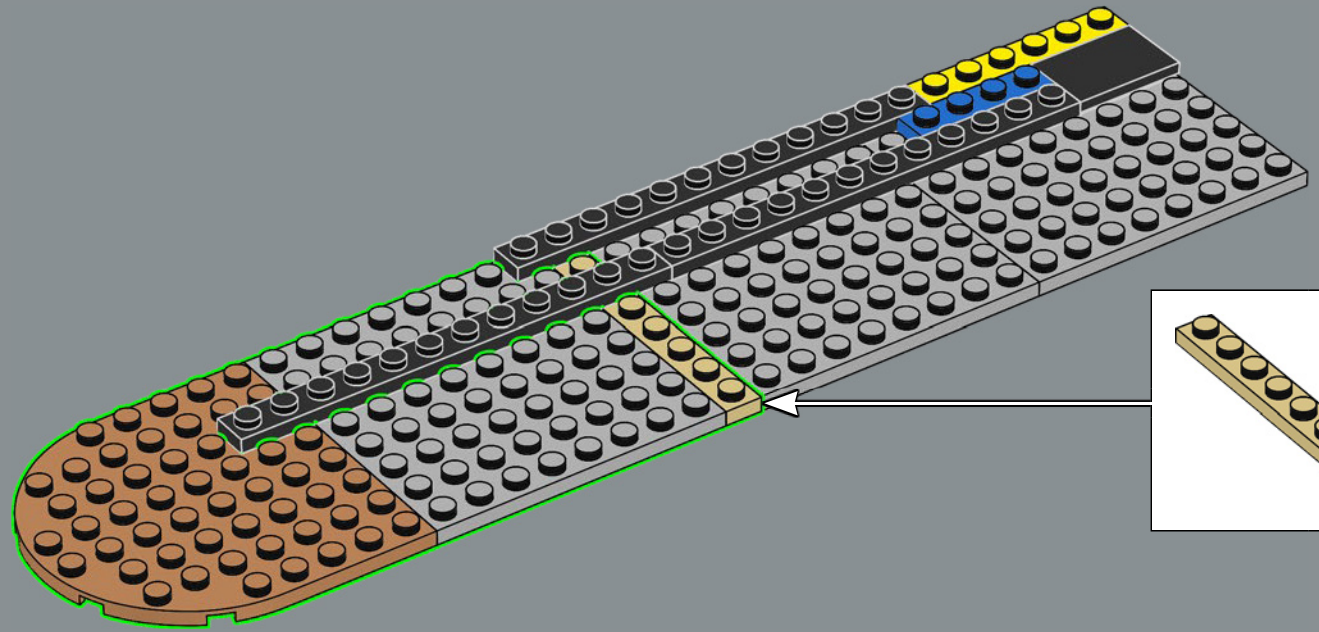

307

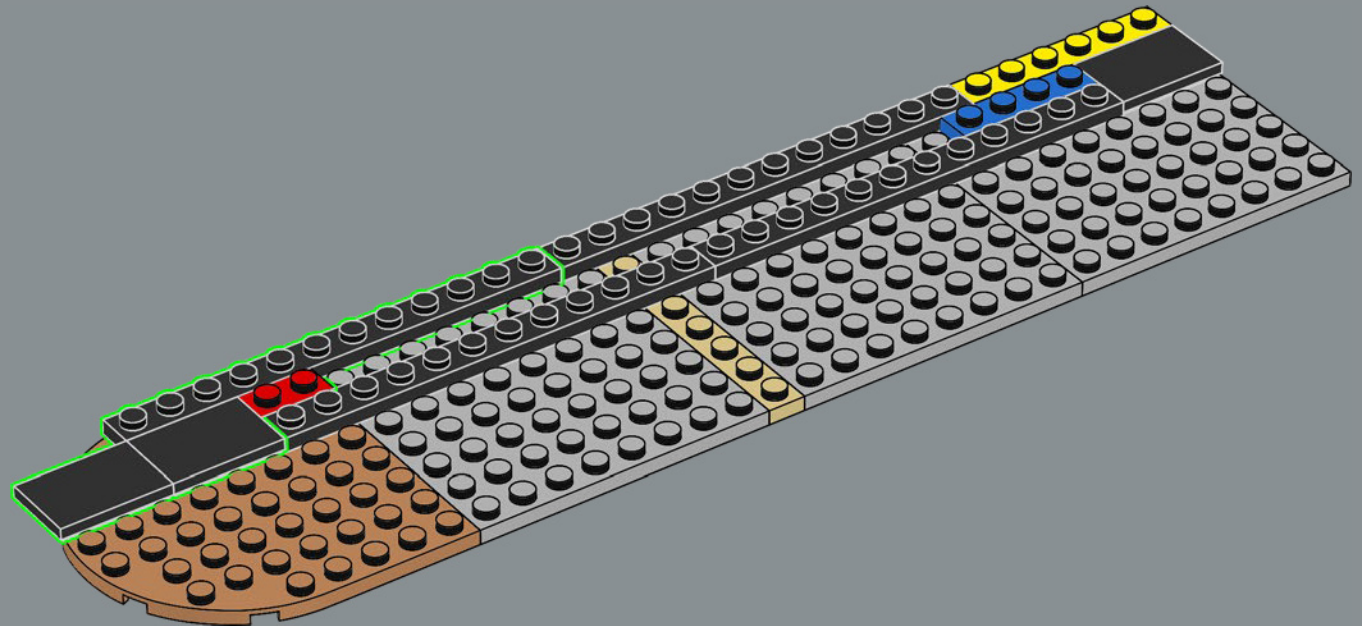

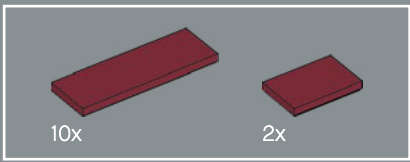

308

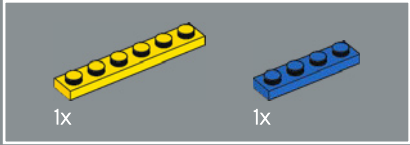
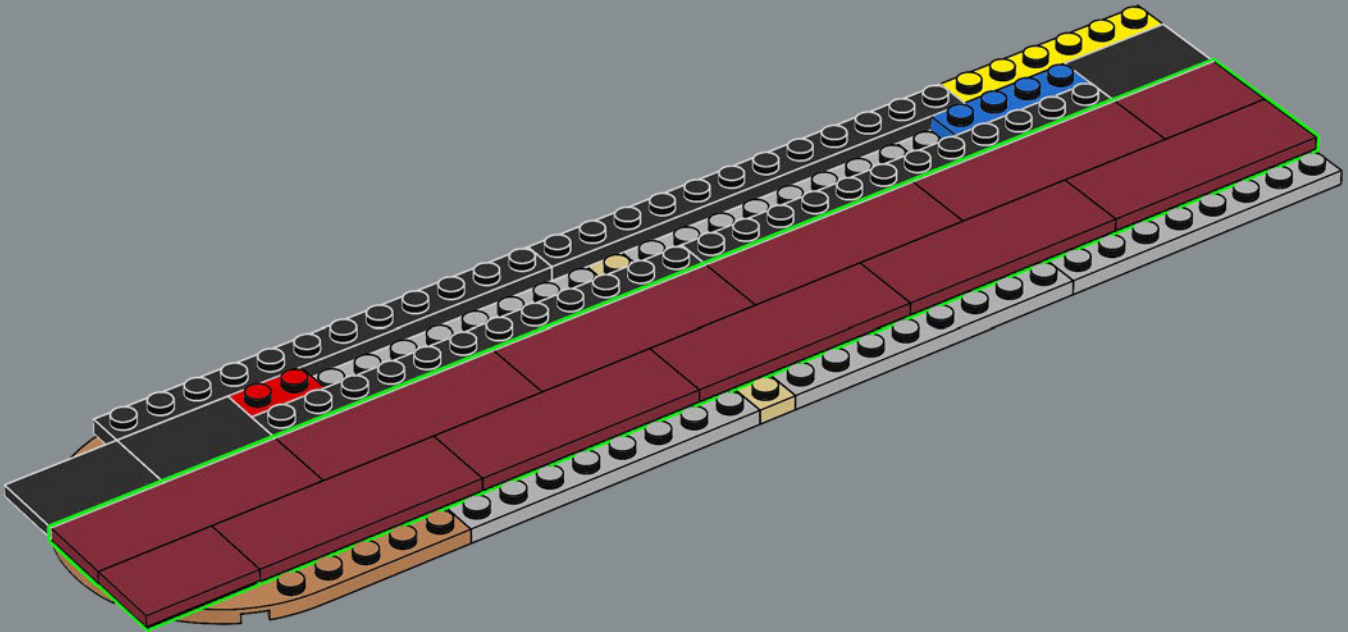

309

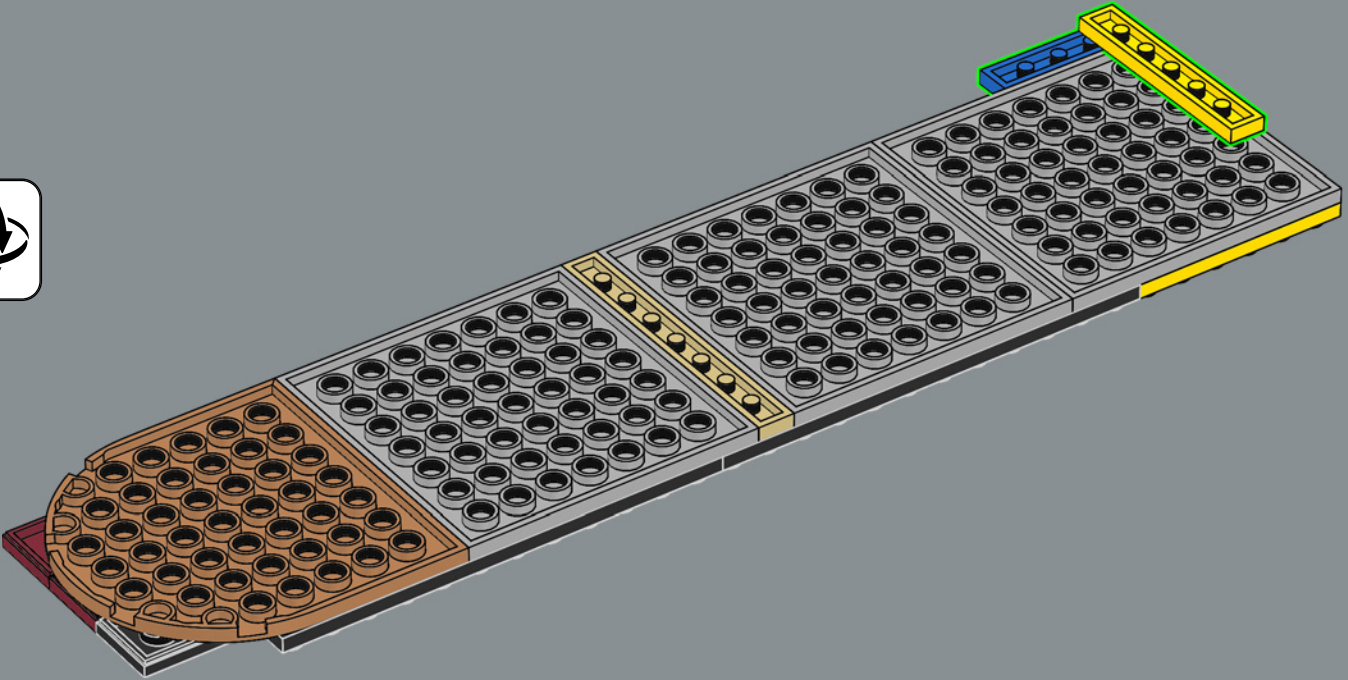

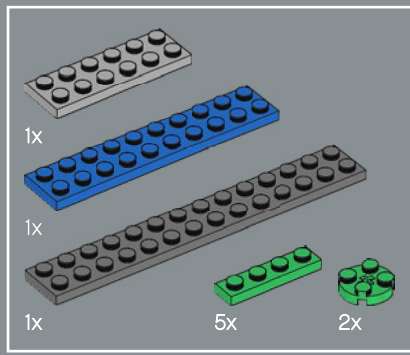

310

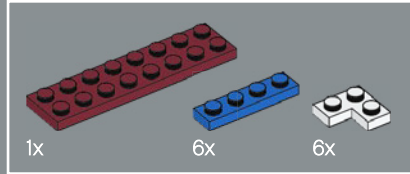
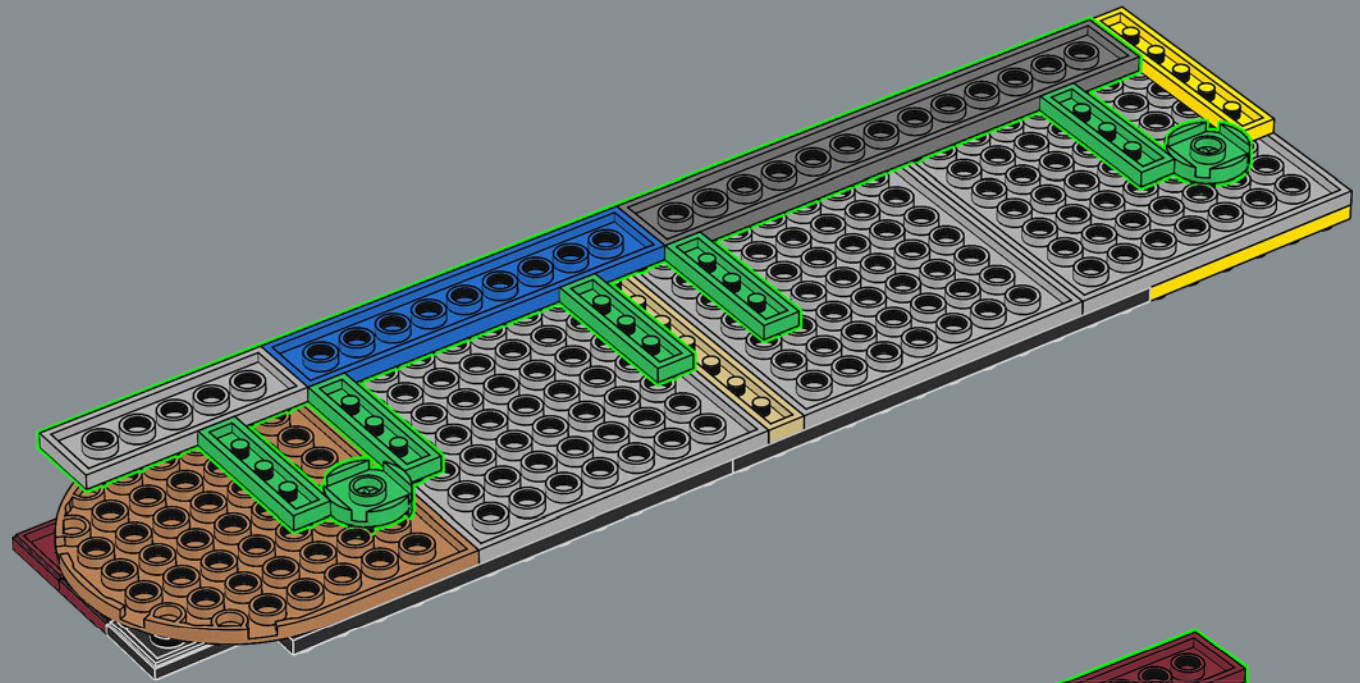

311

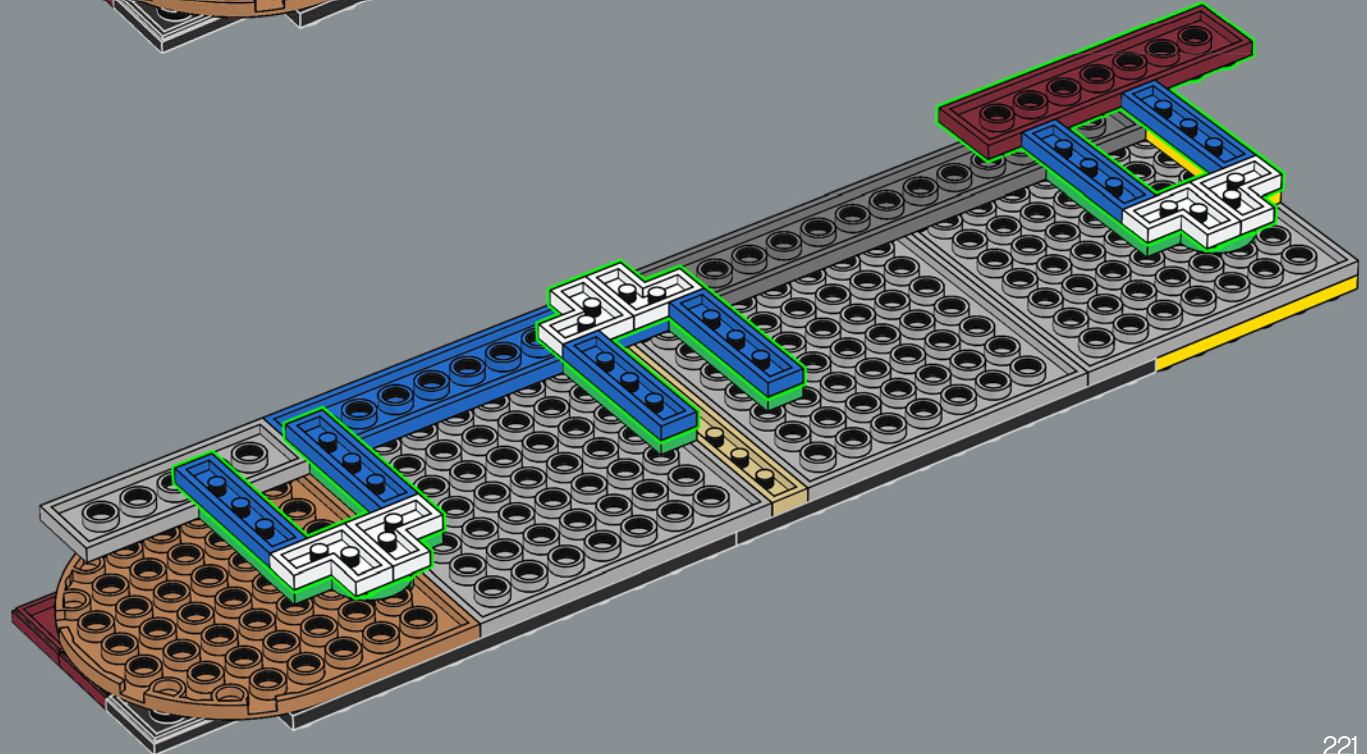

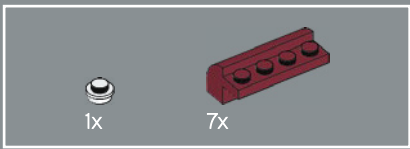

312

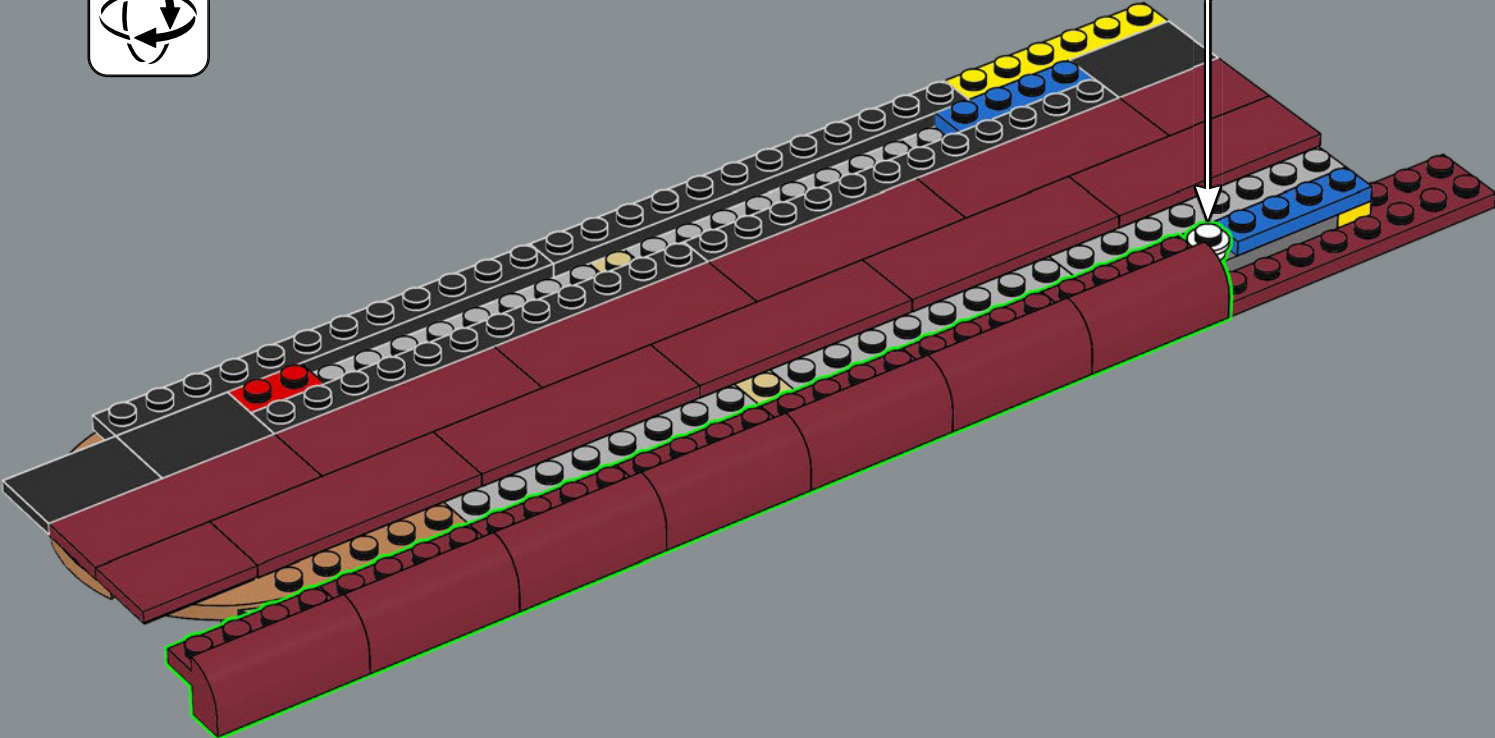

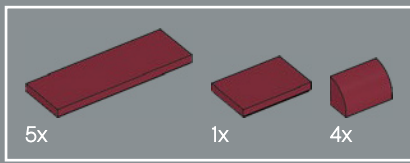

313

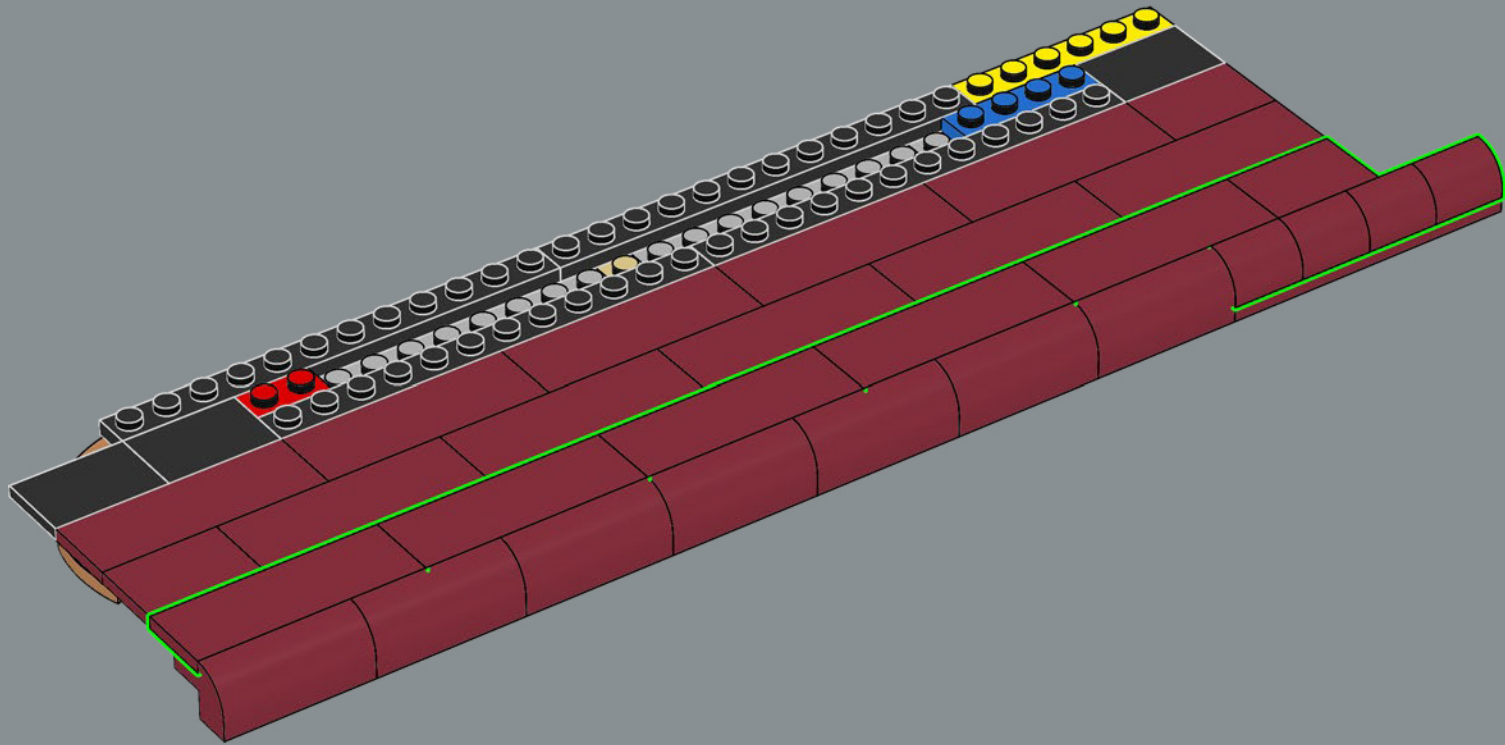

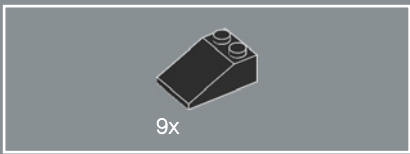

314

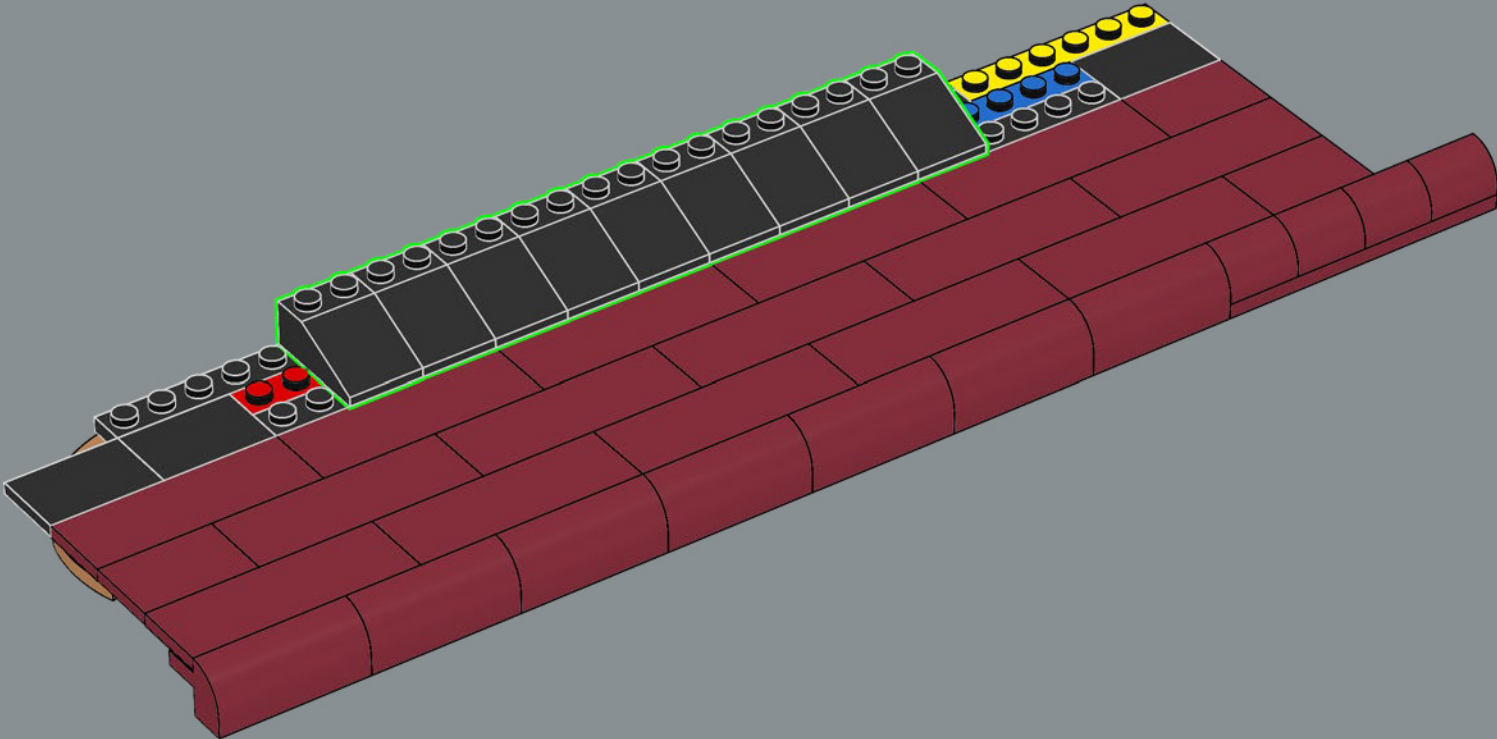

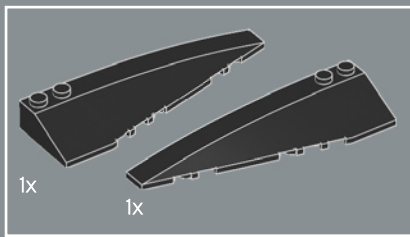

315

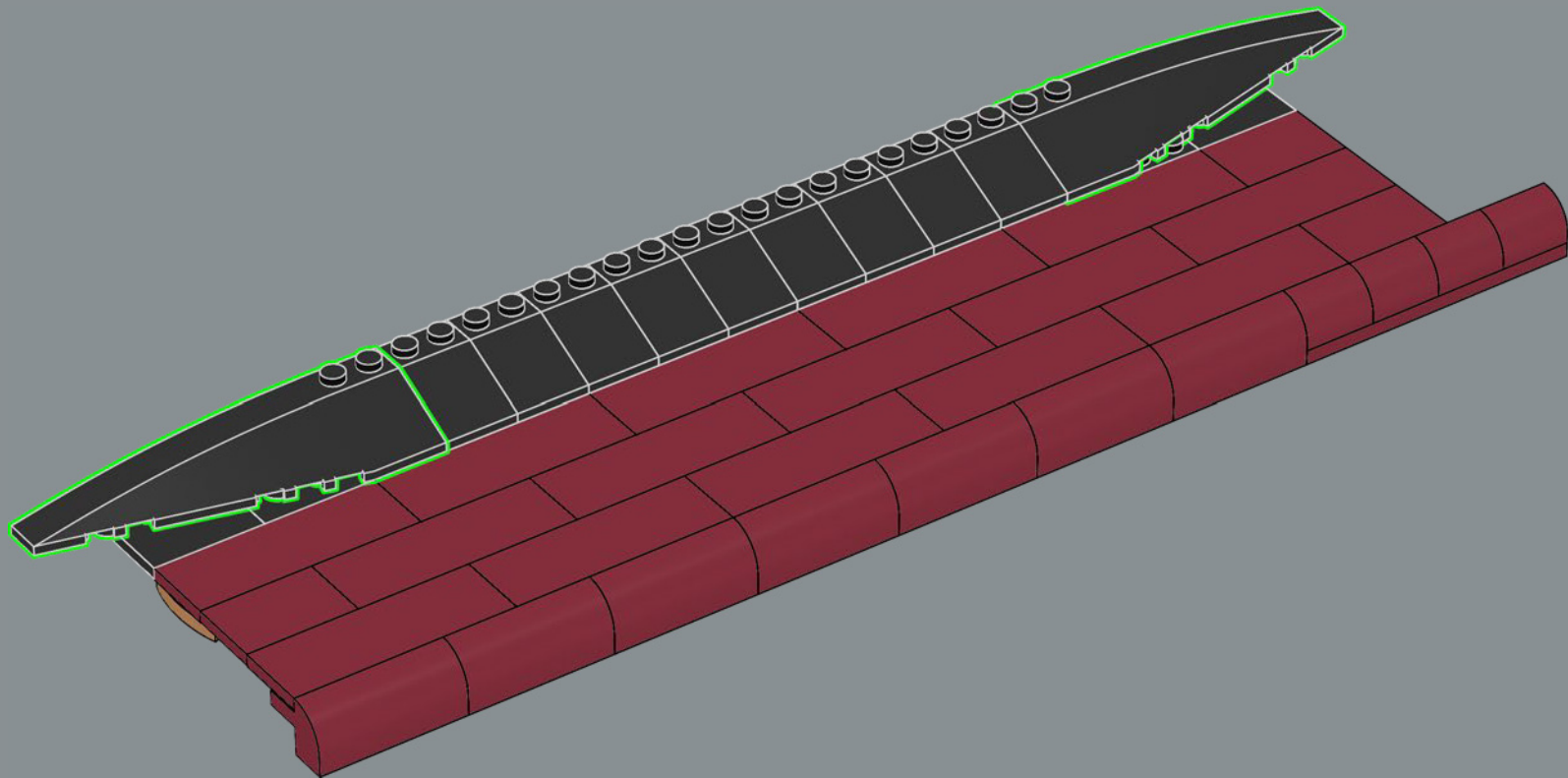

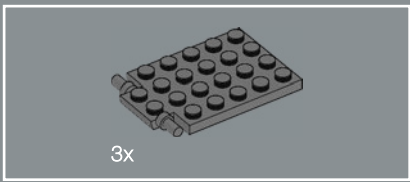

316

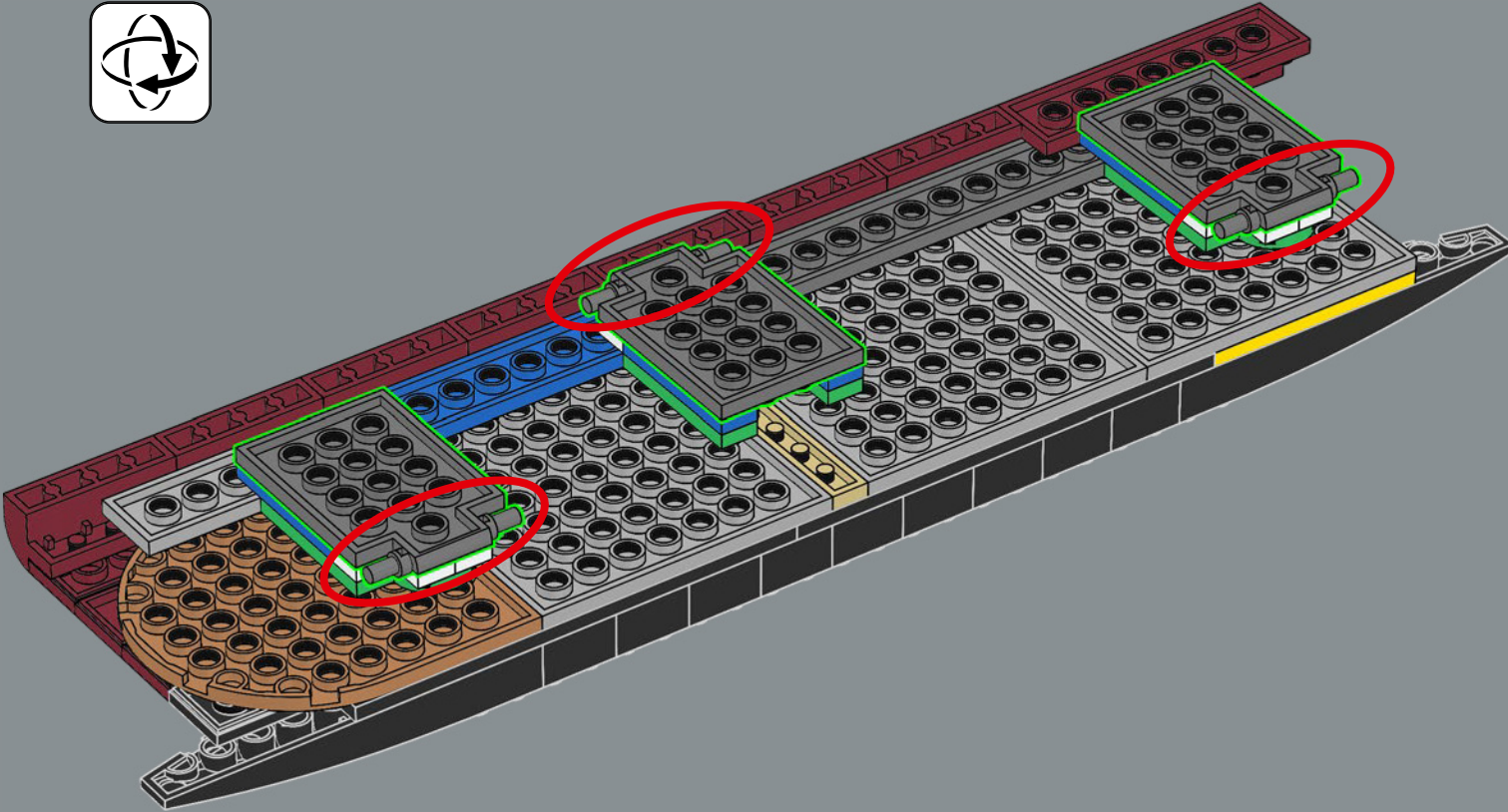



317

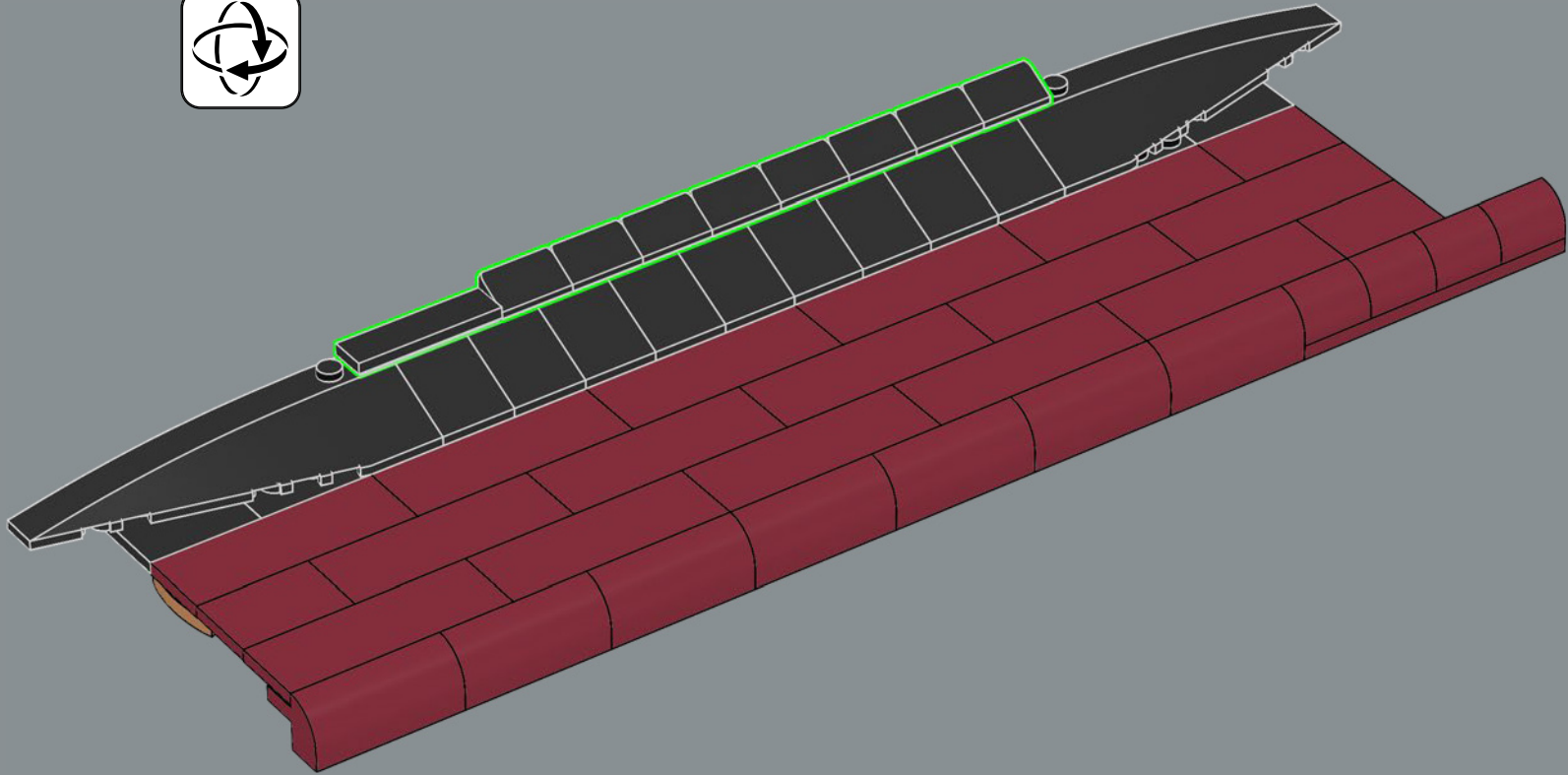

318

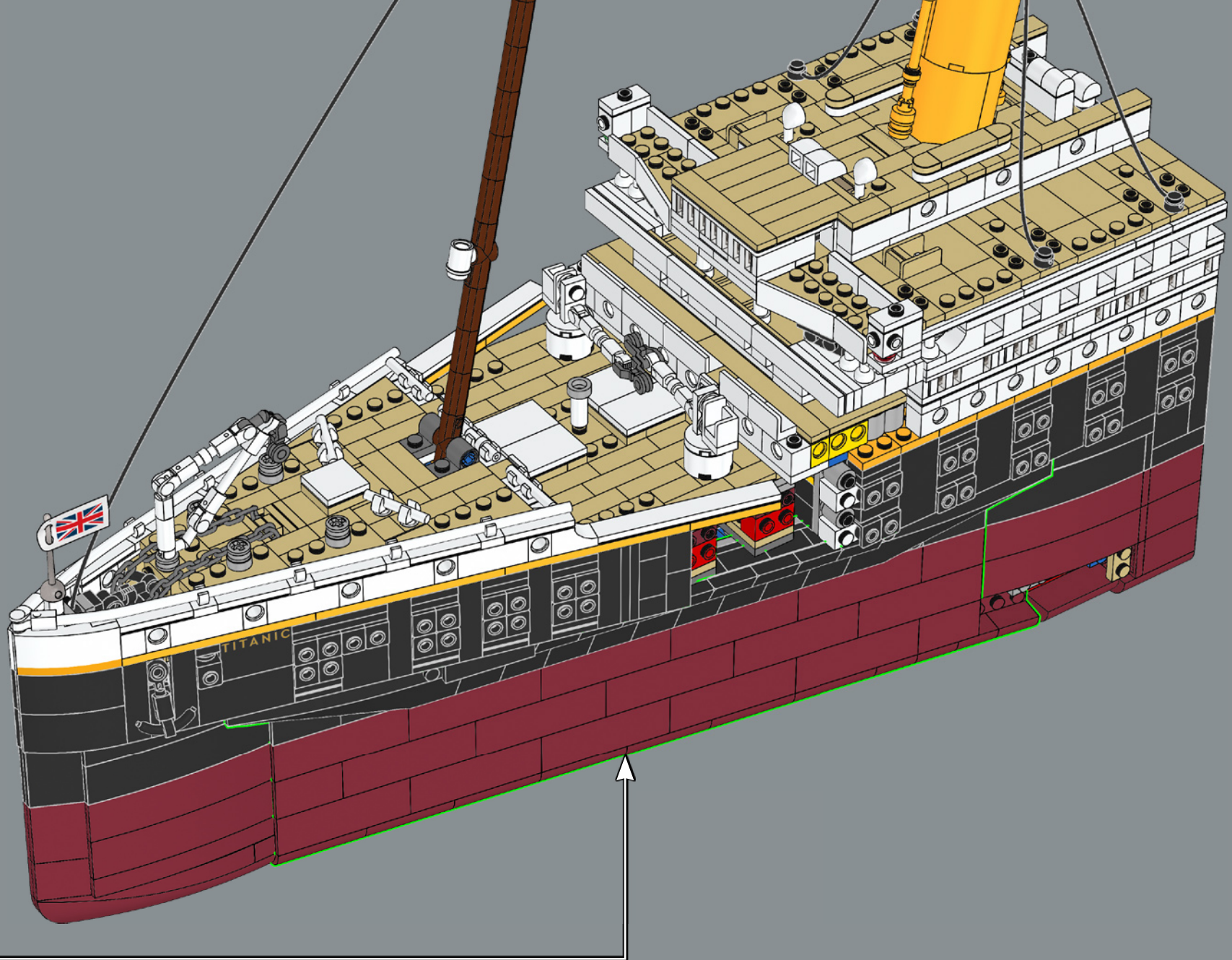

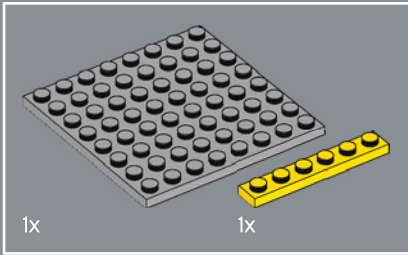
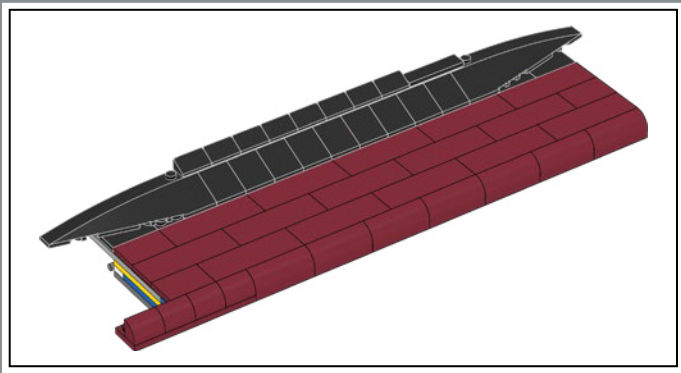

319

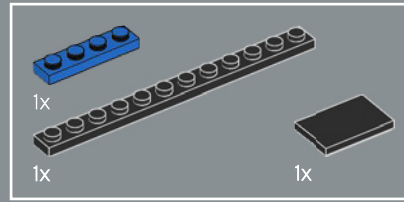
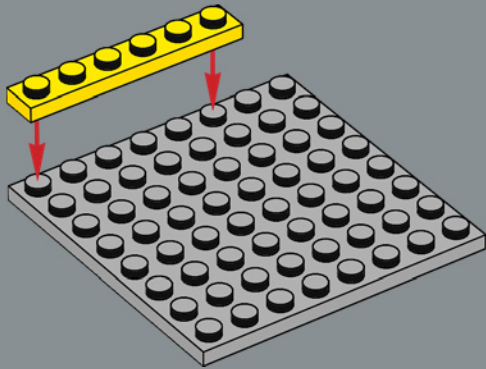

320

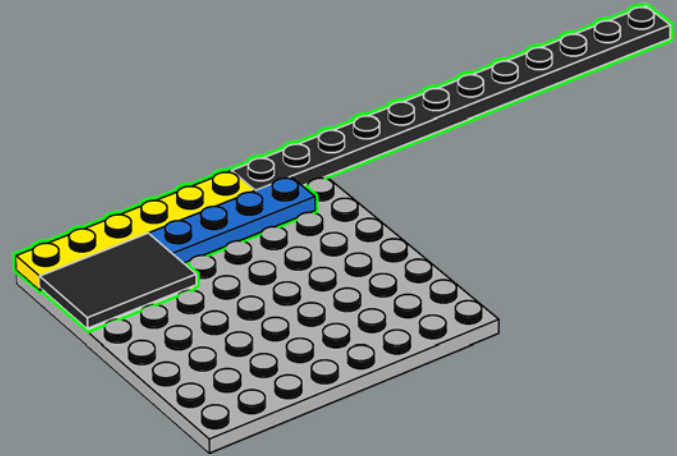

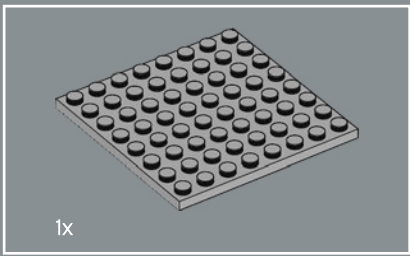

321

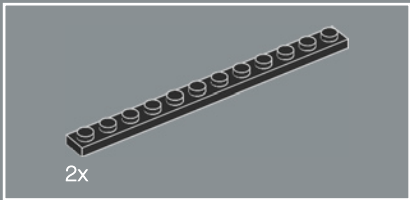
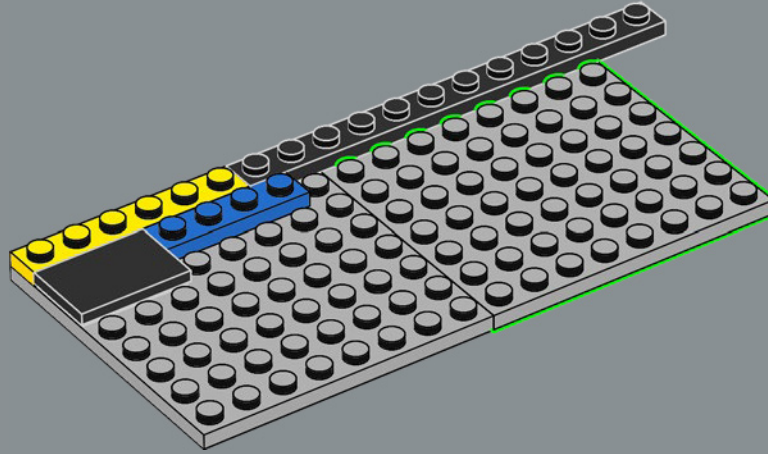

322

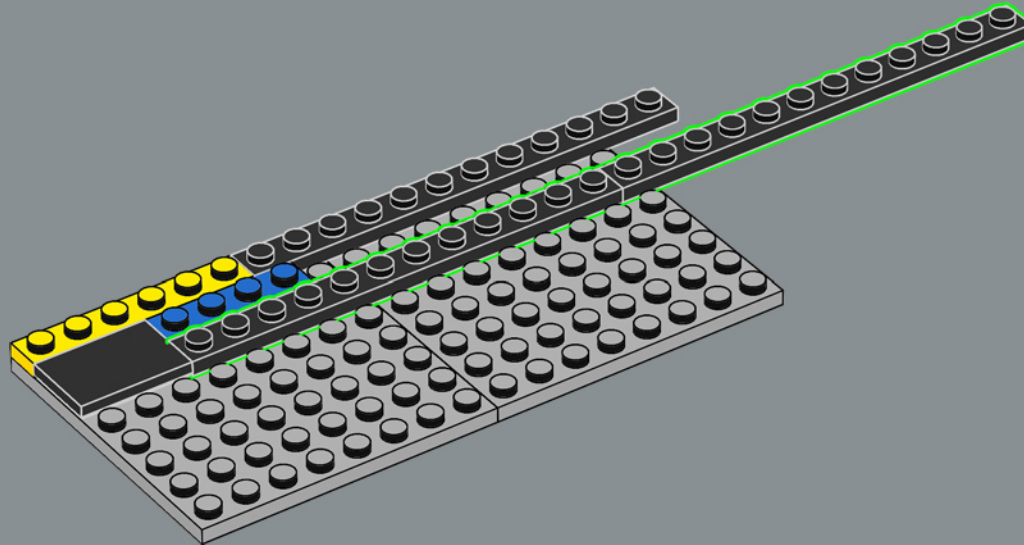

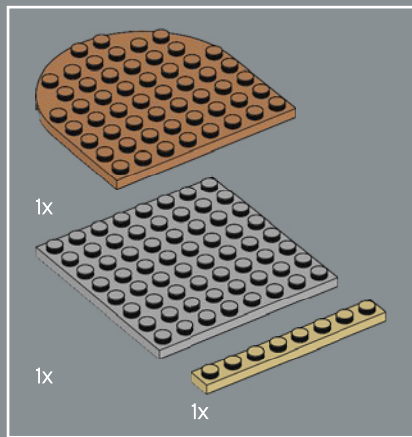

323

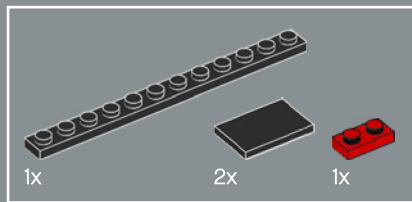
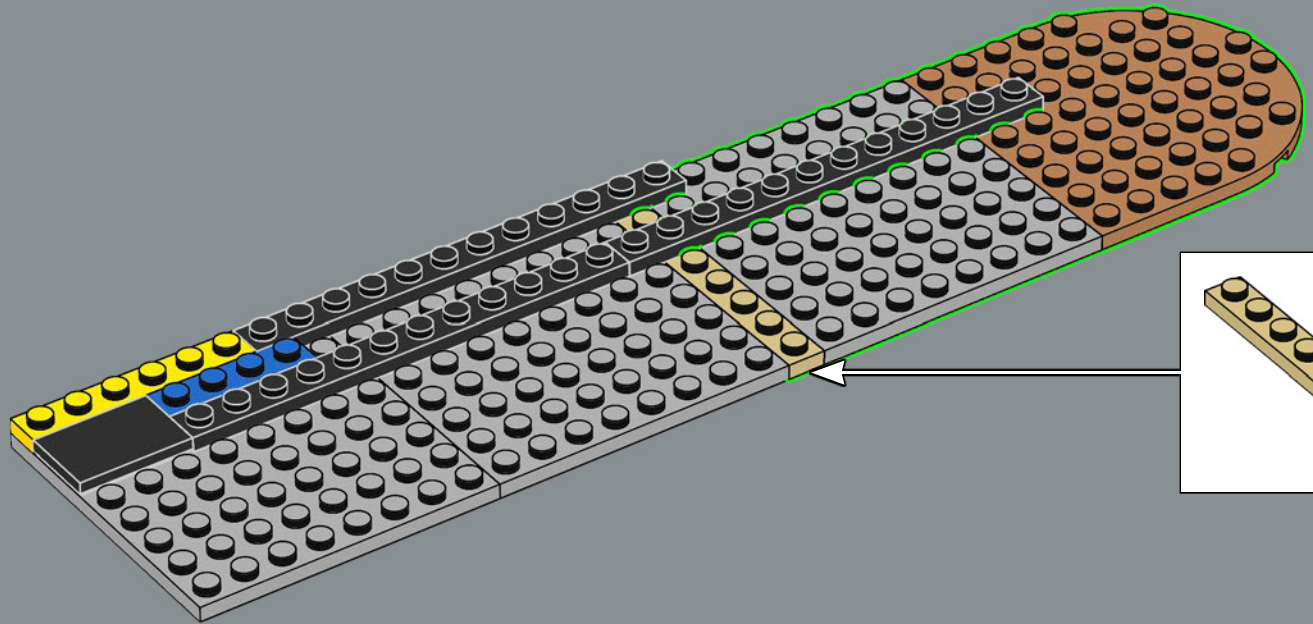

324

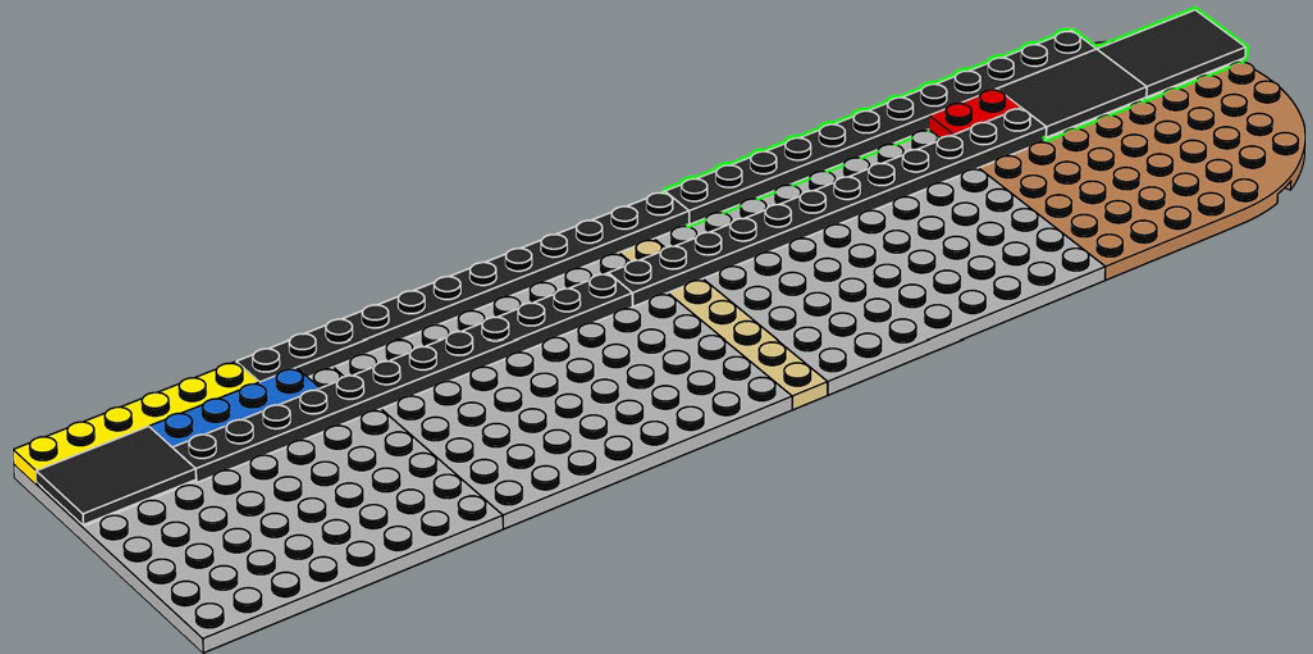

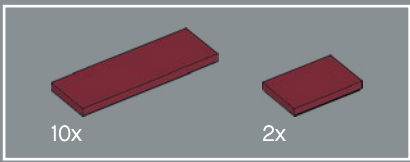

325

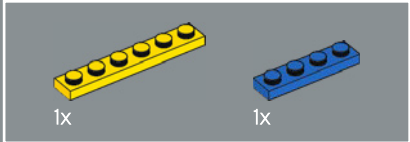
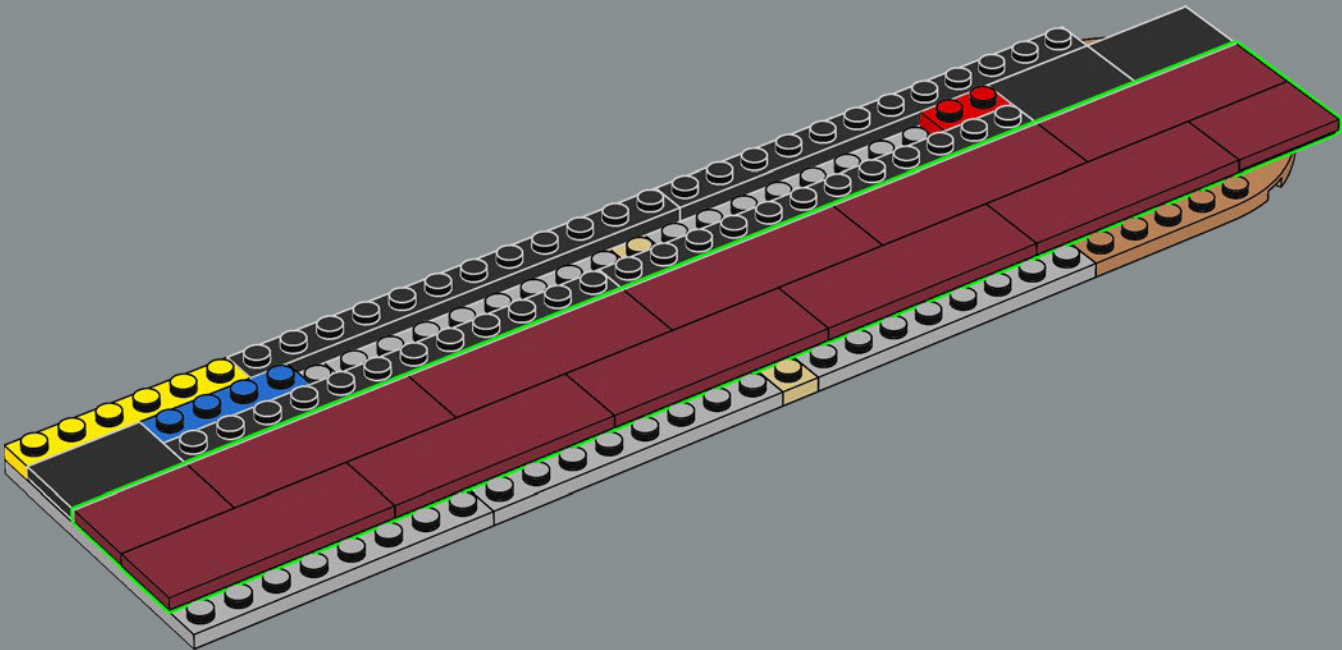

326

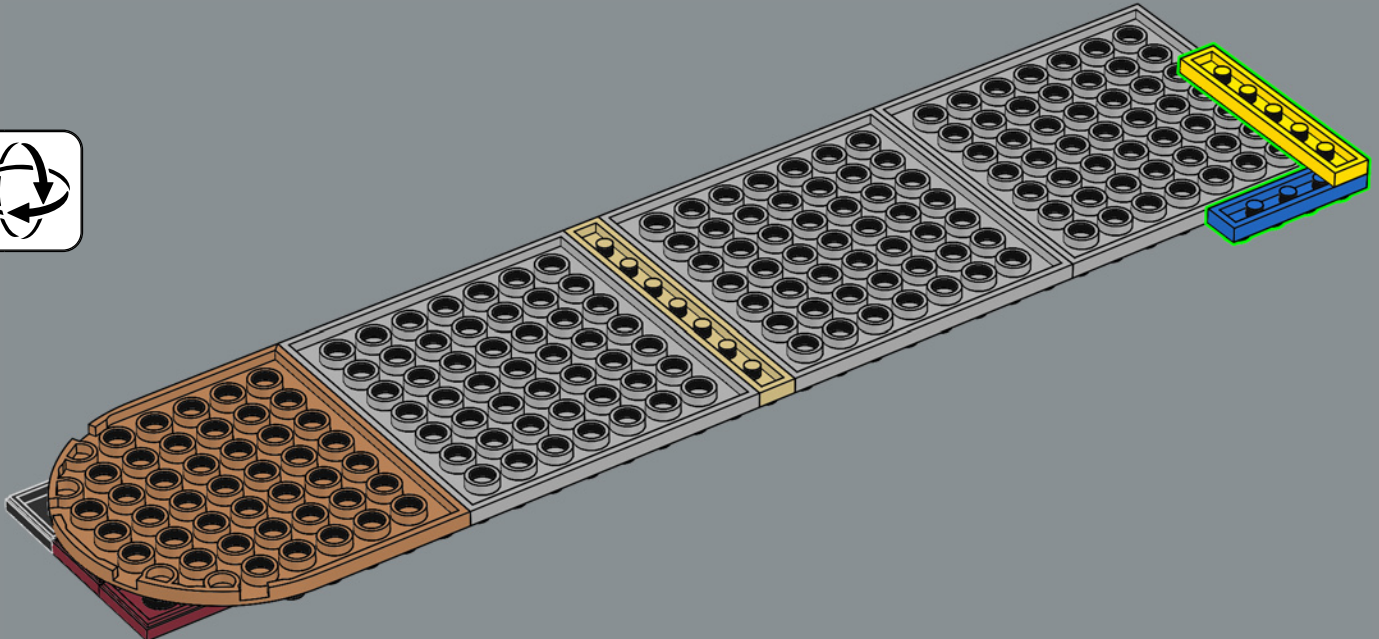

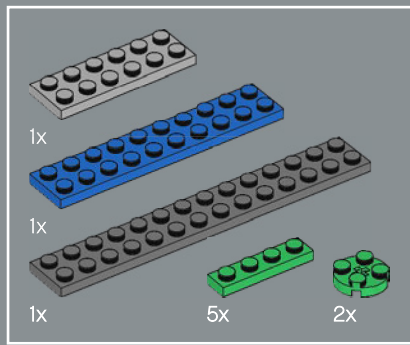

327

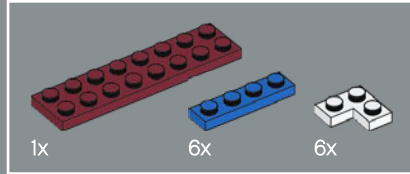
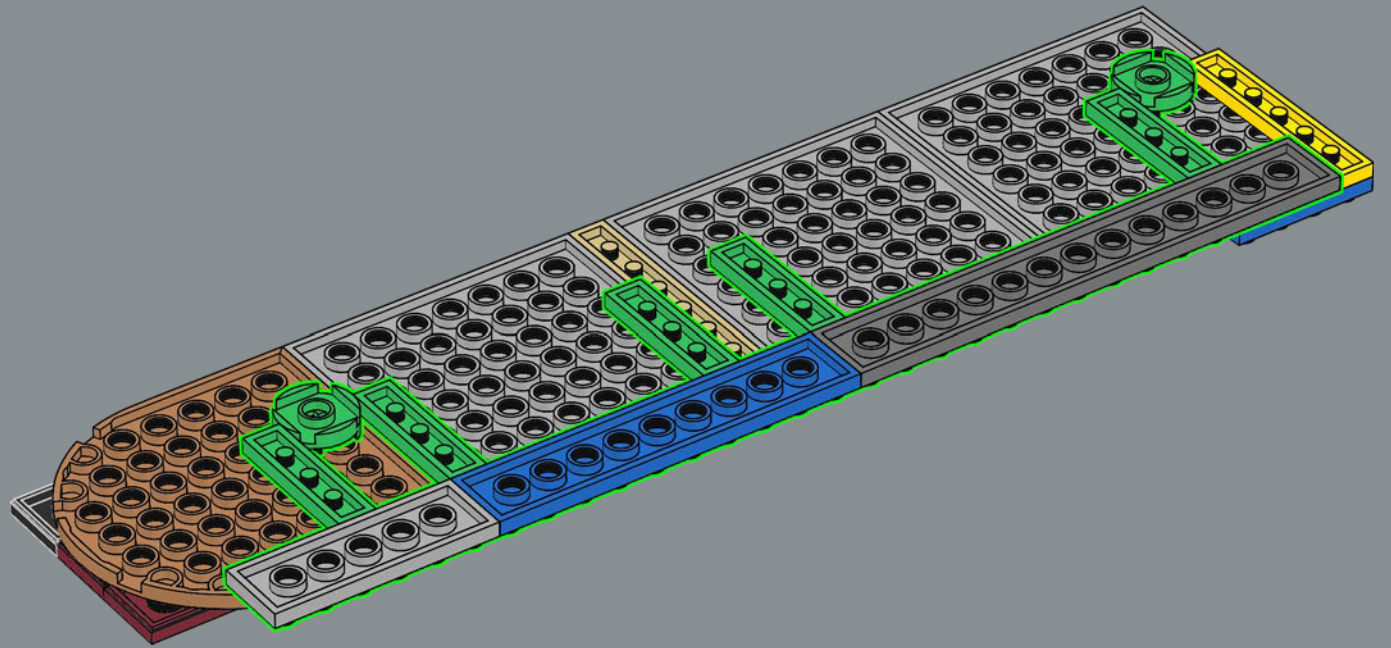

328

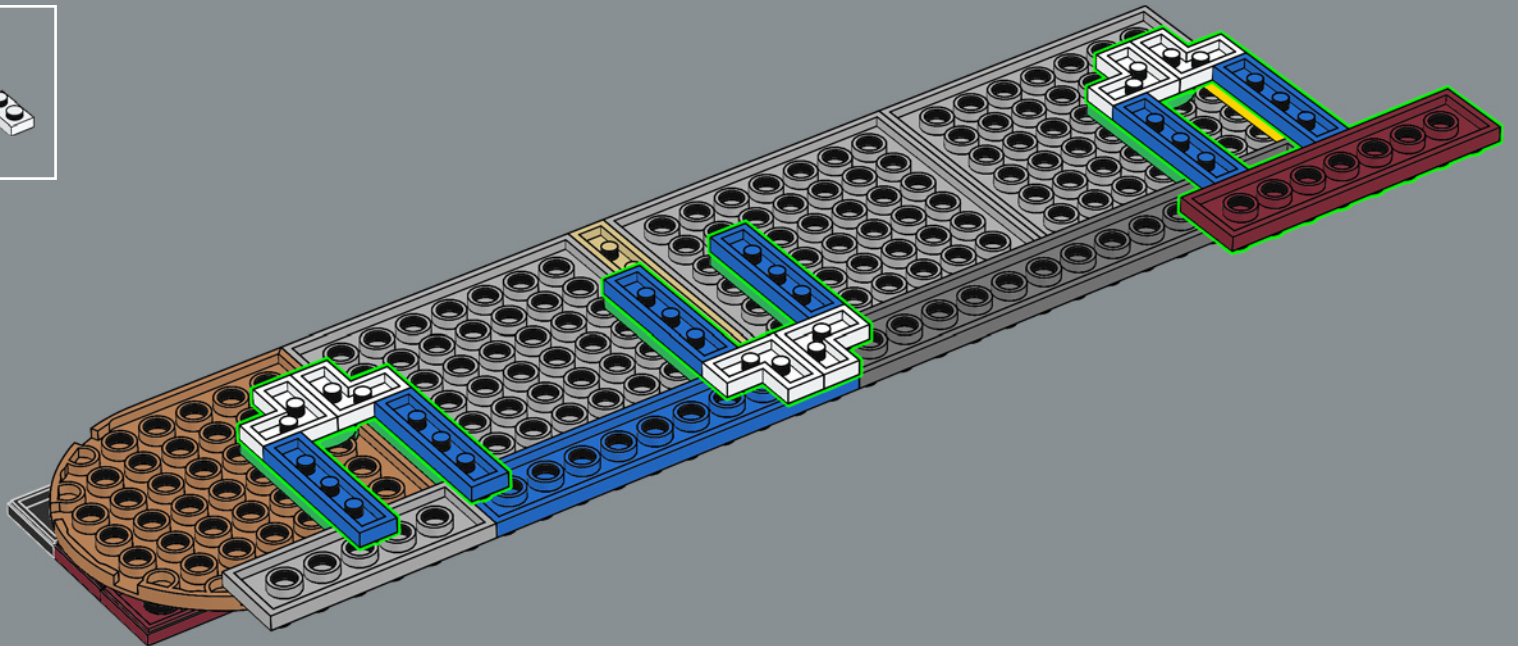

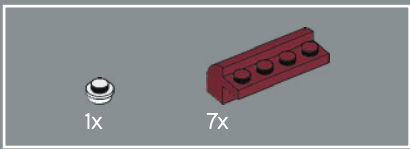

329

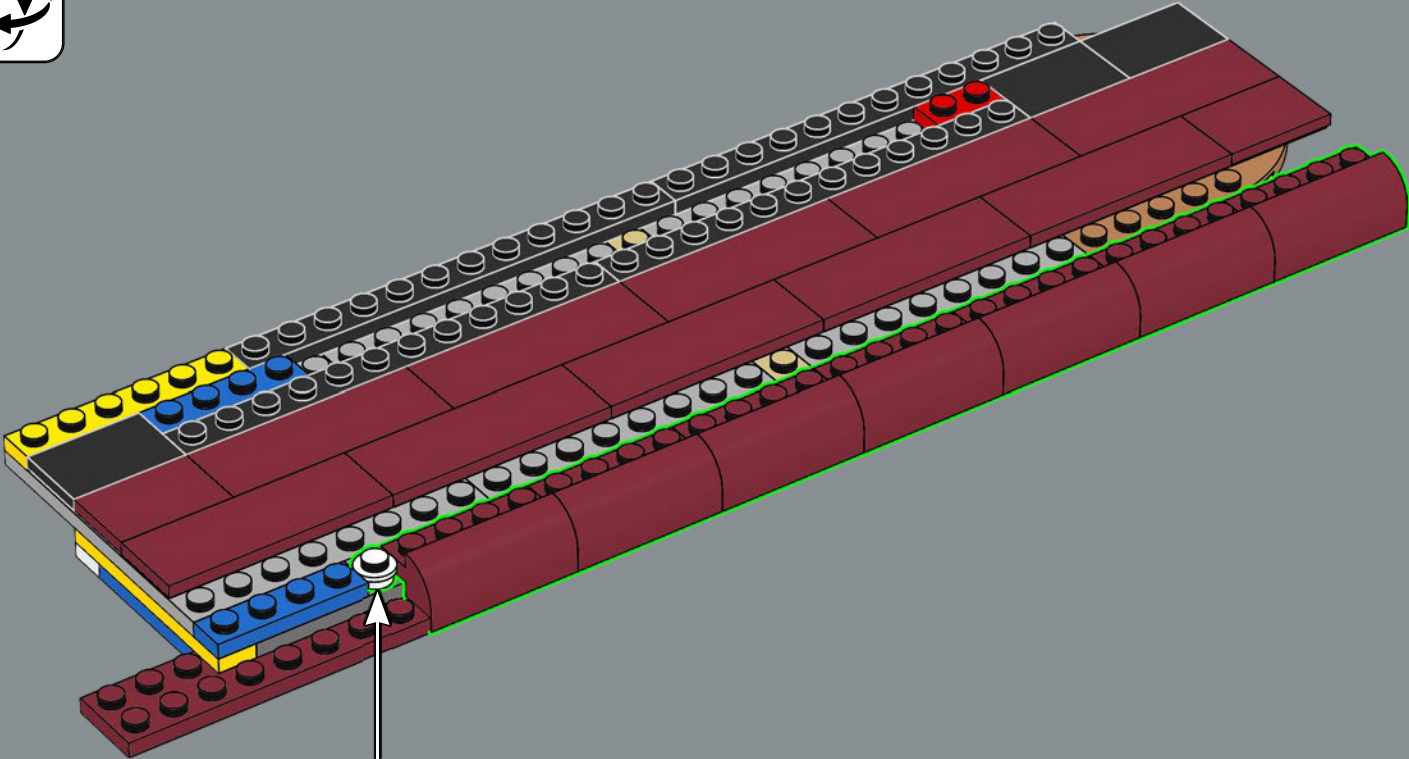

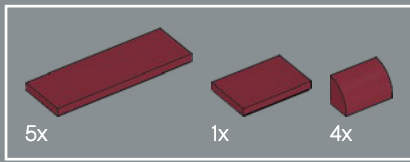

330

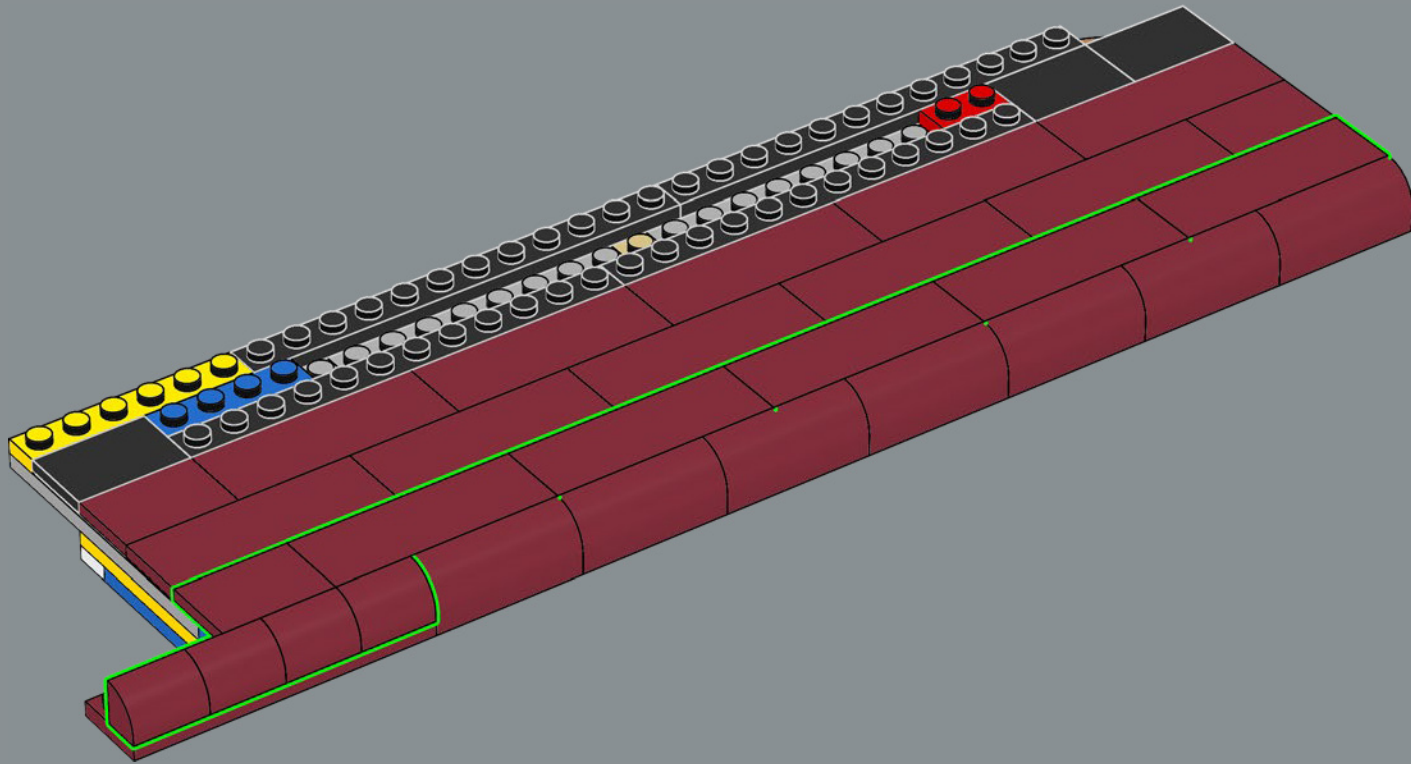



331

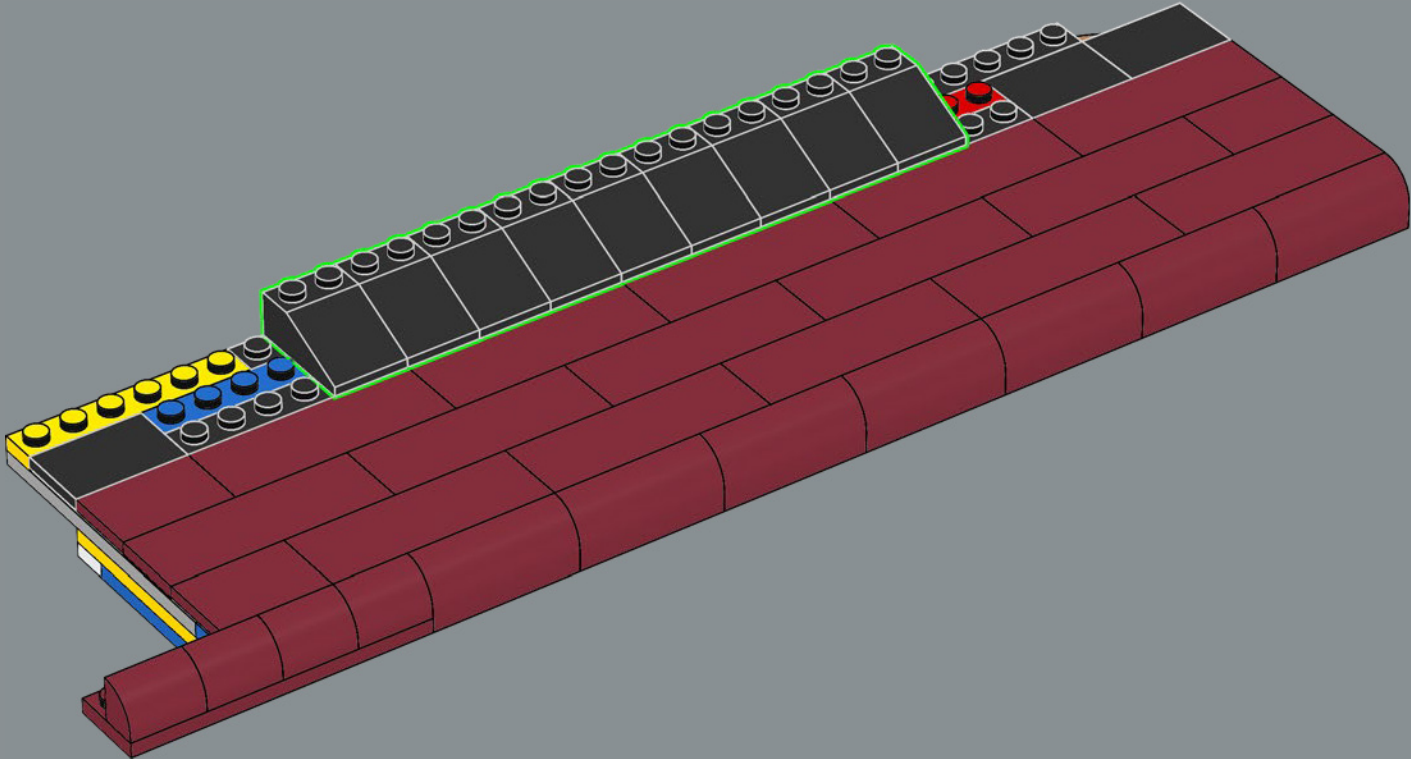

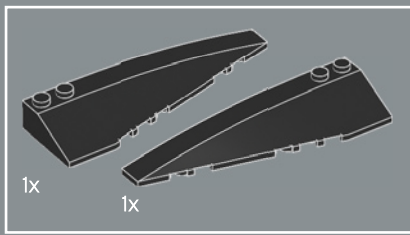

332

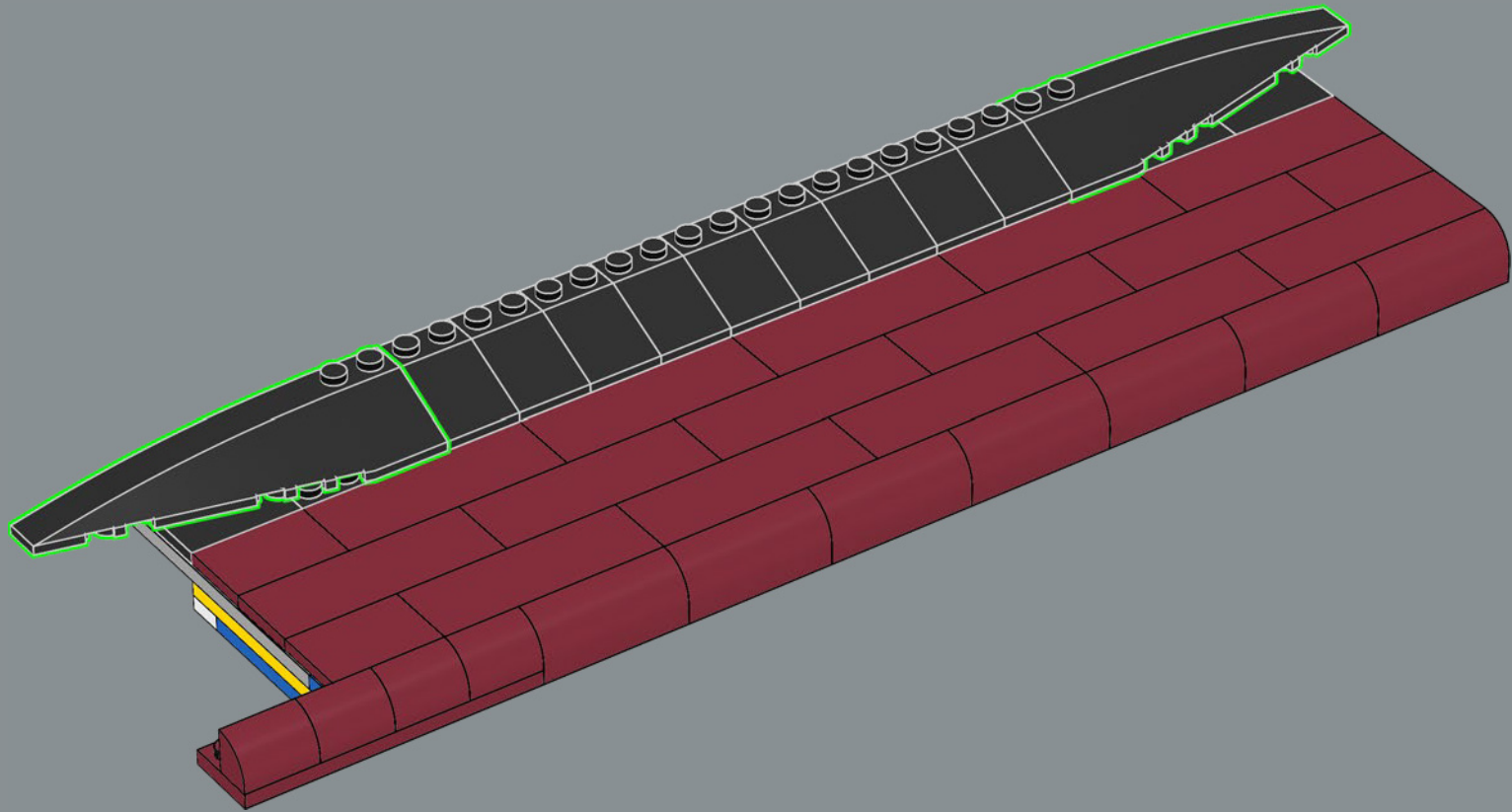

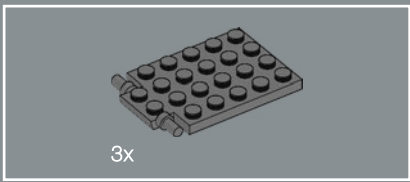

333

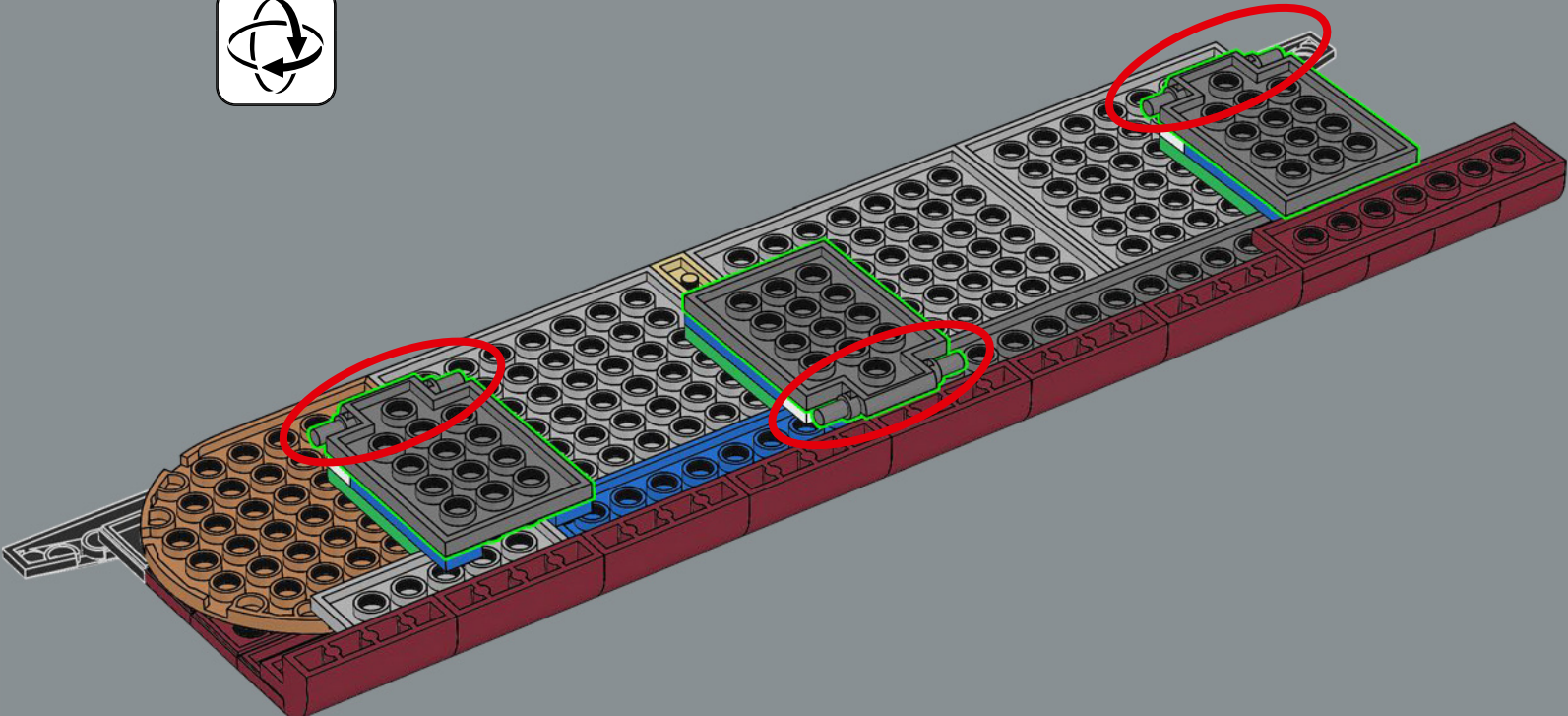



334

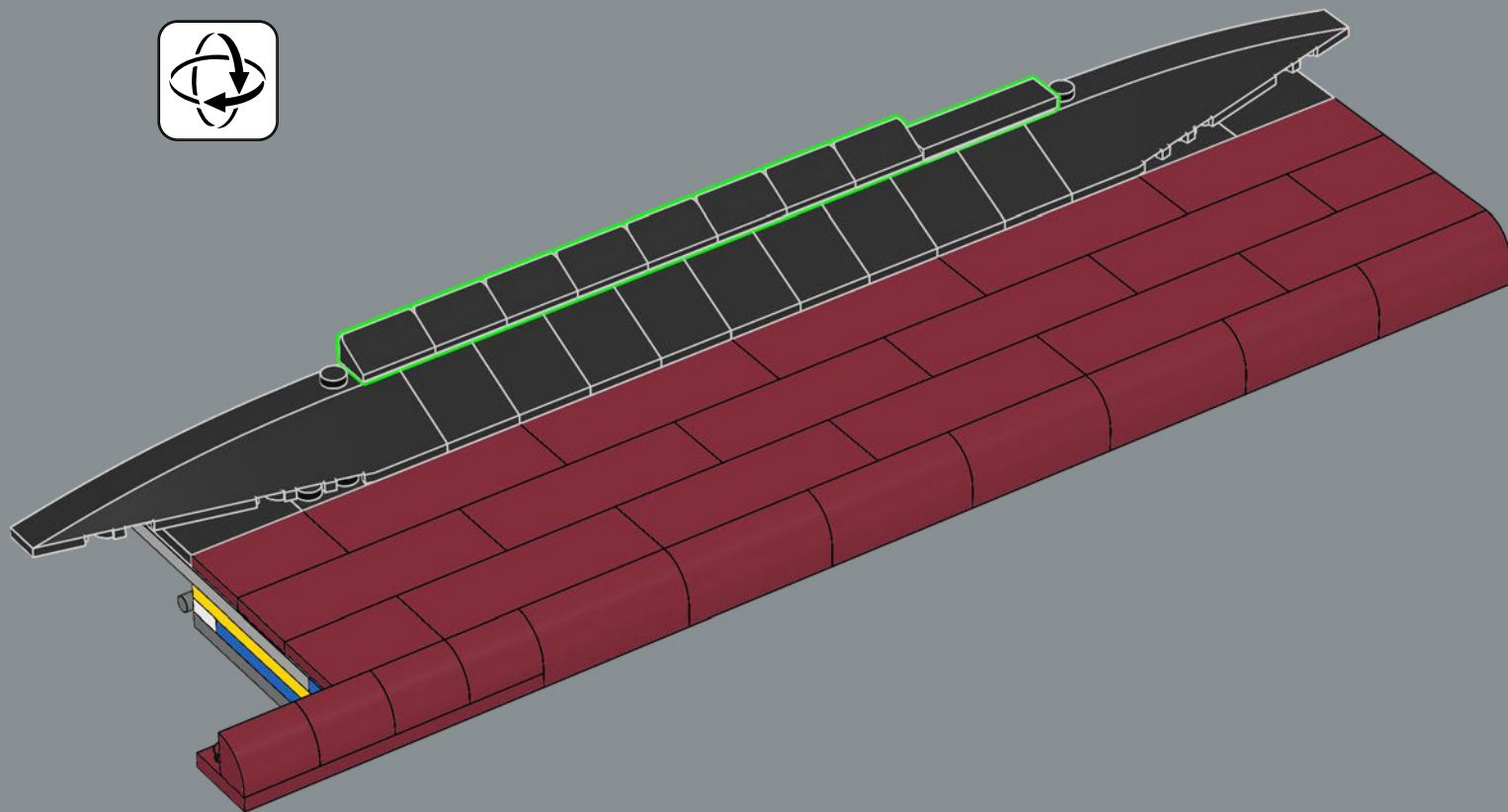

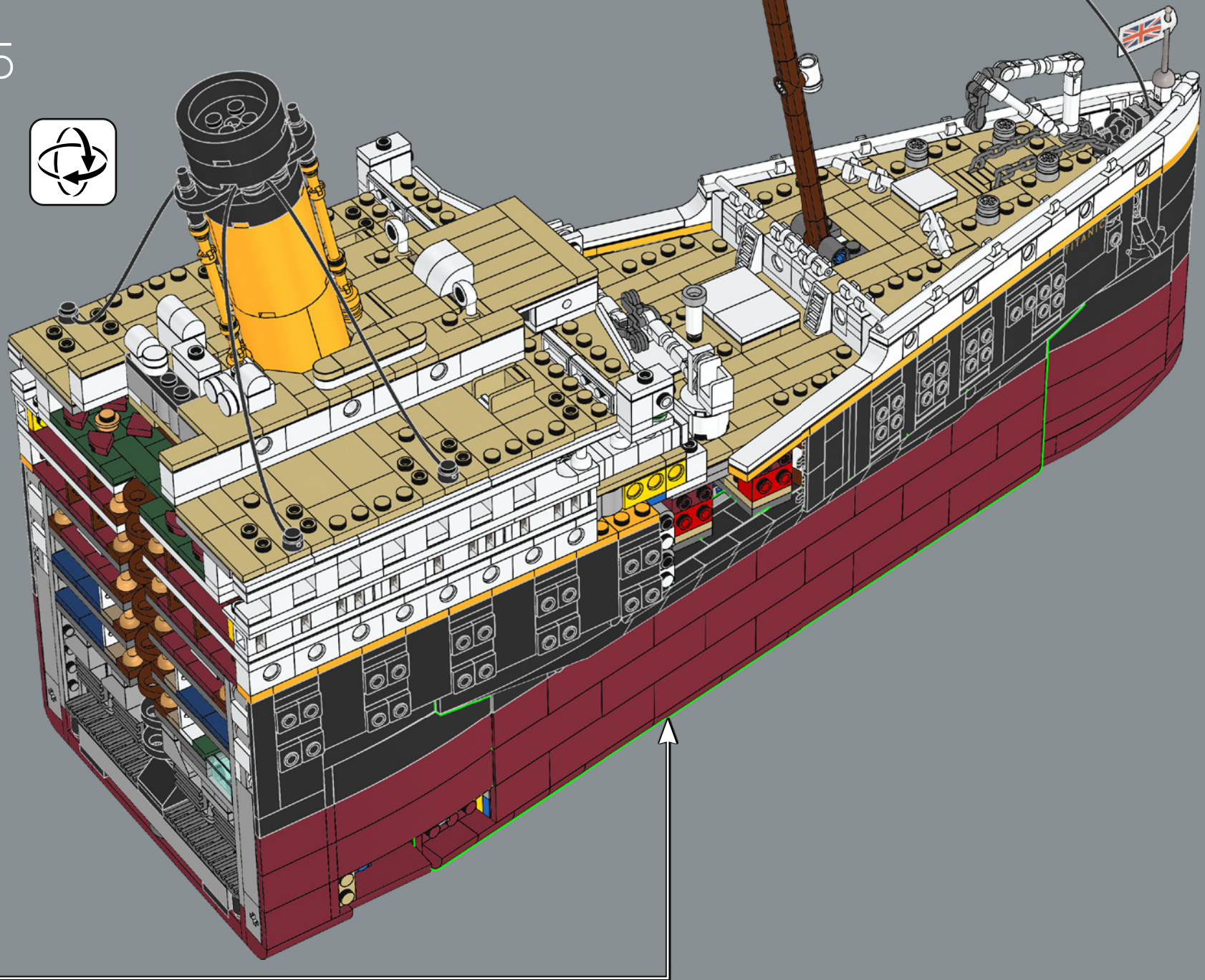

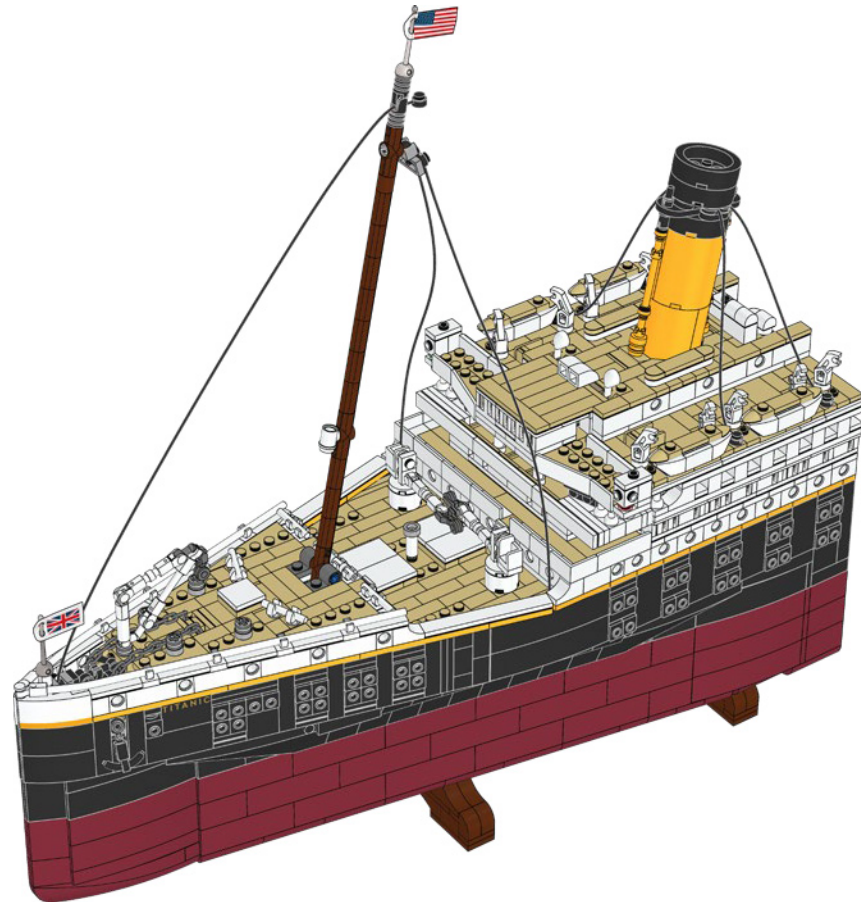
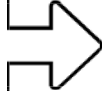

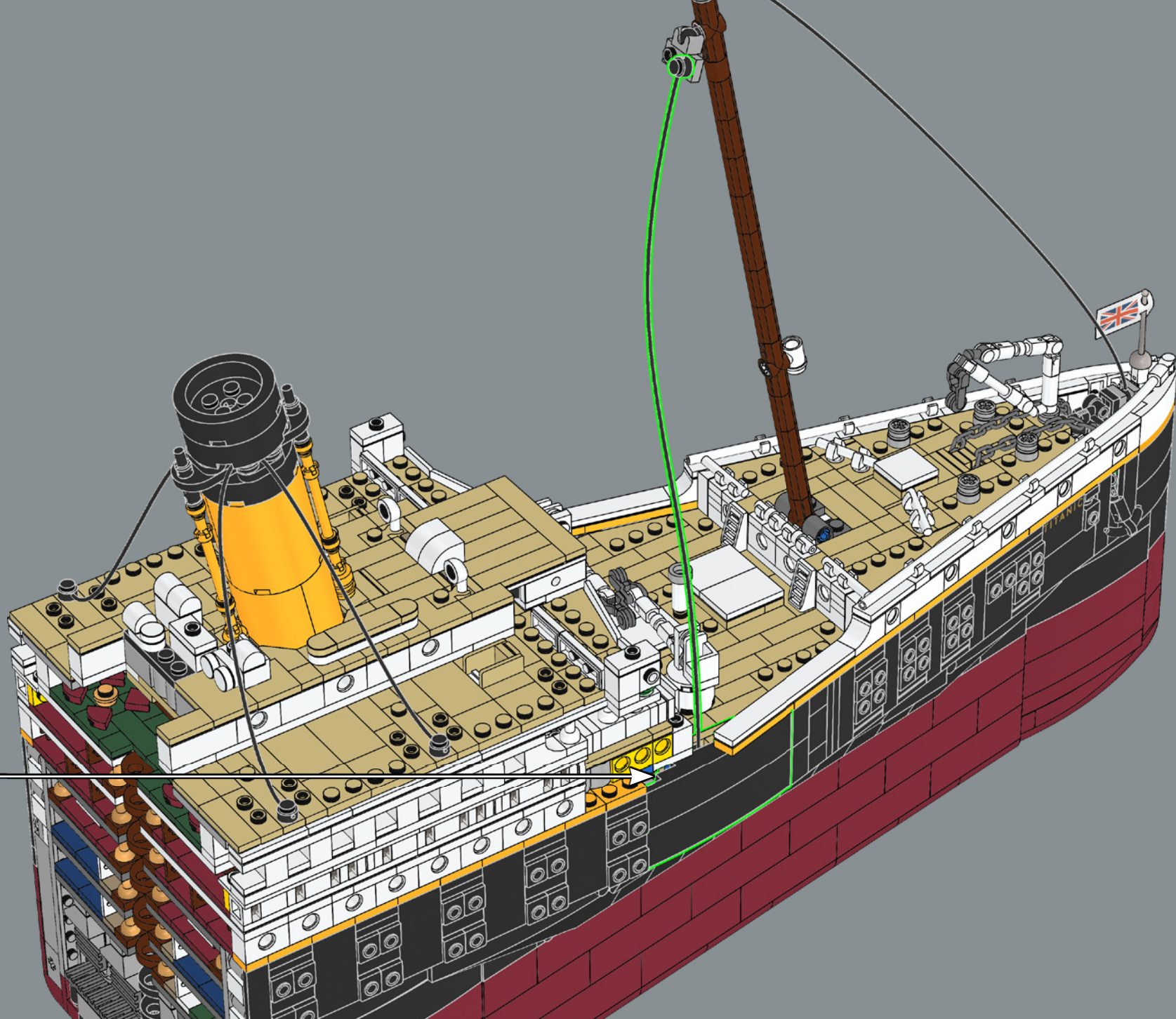

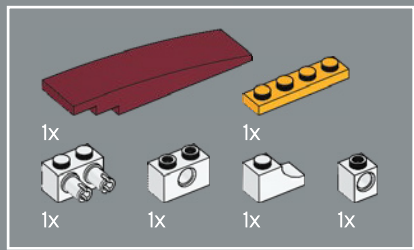

337

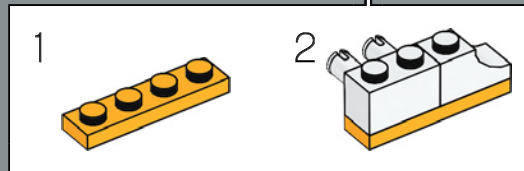
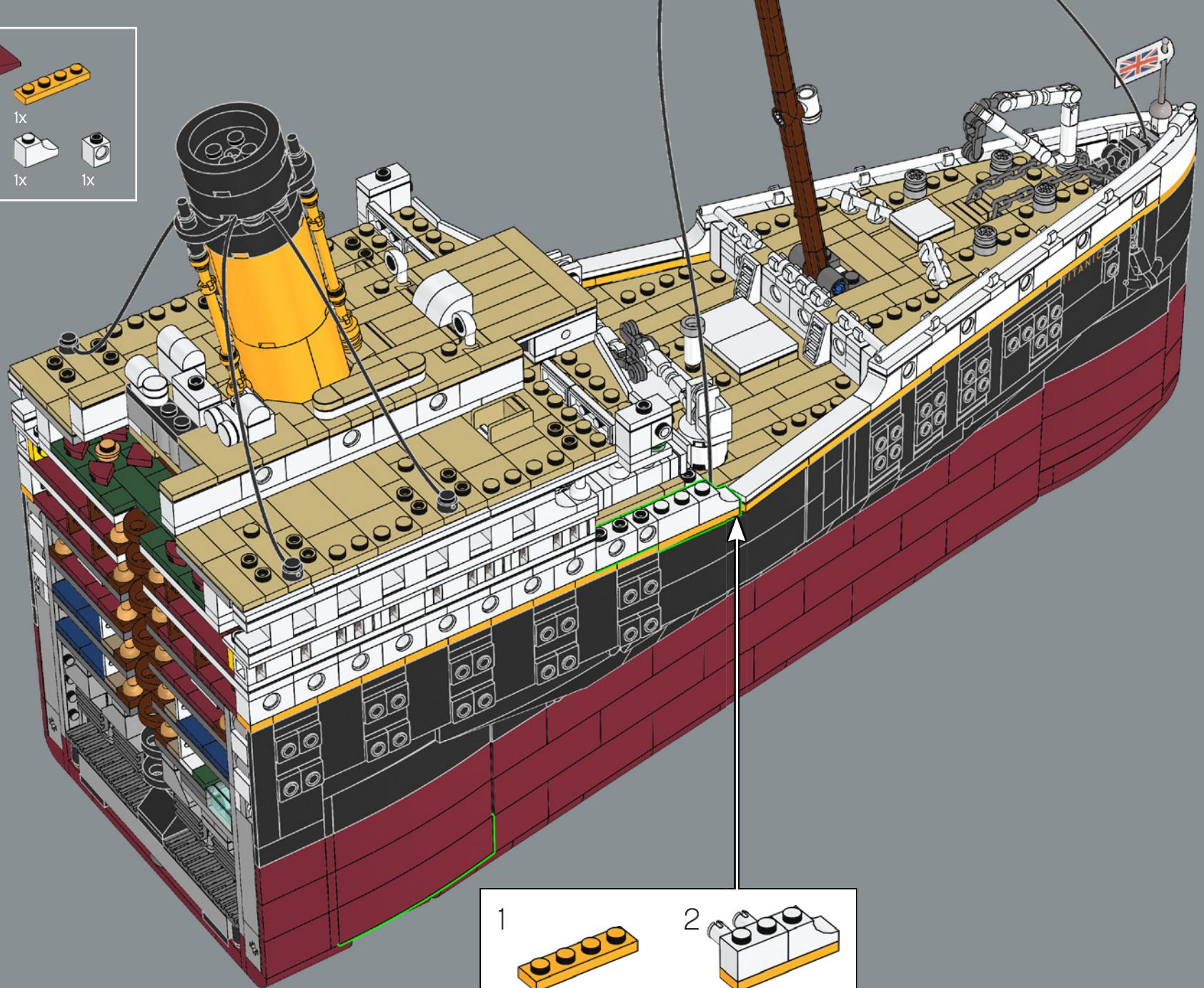

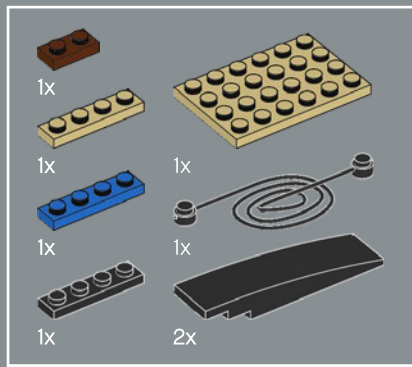

338

1

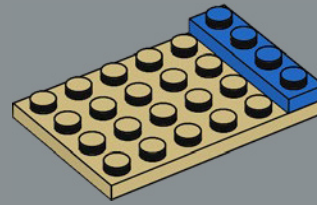

2

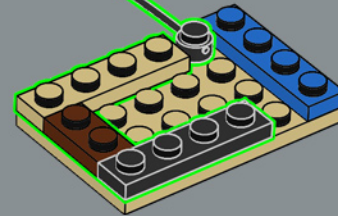

3

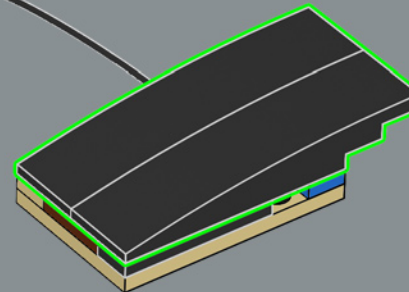

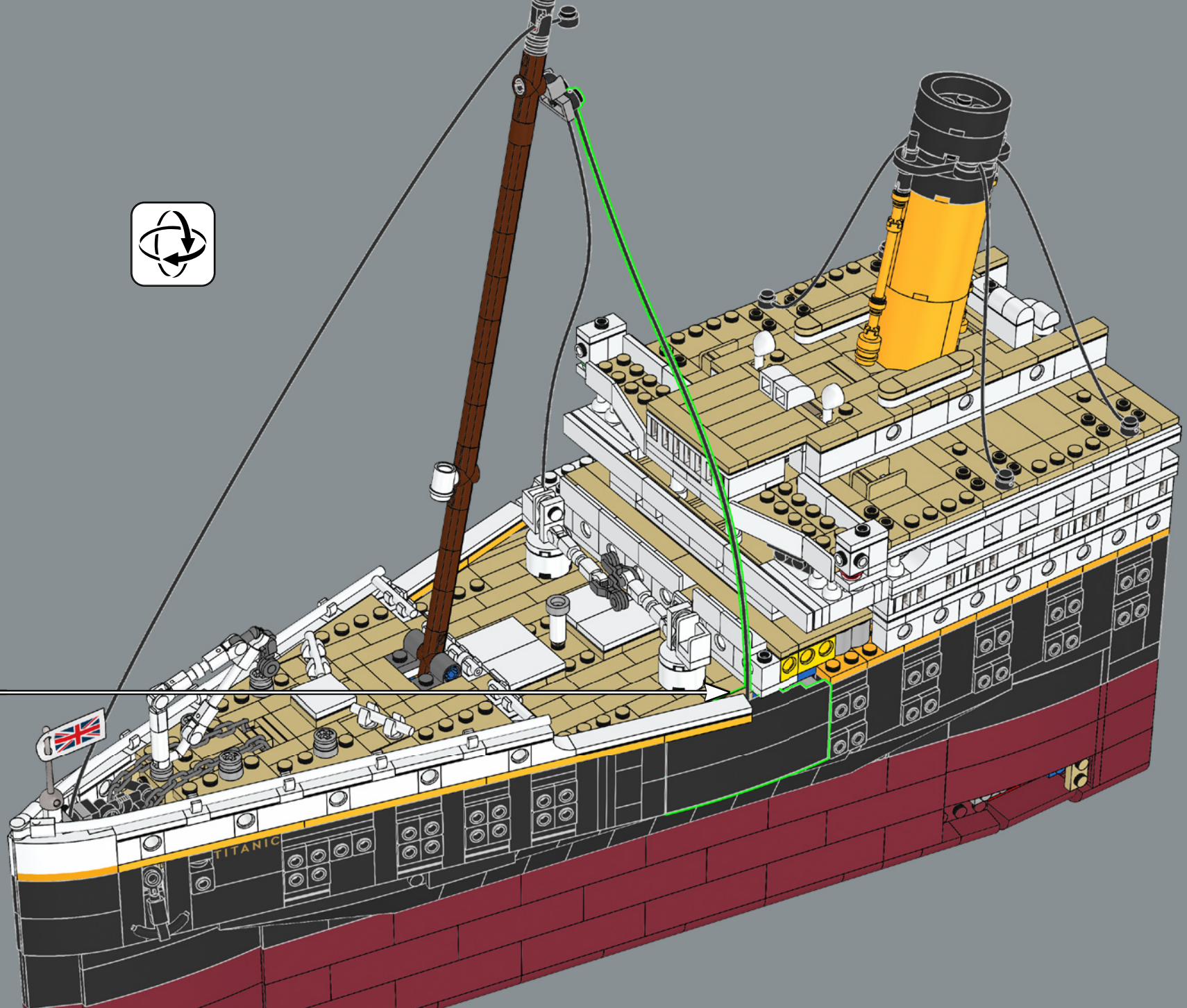

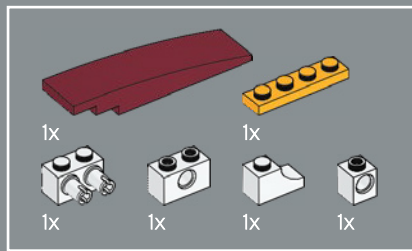

339

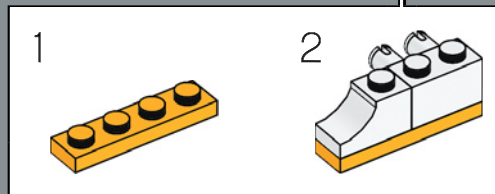
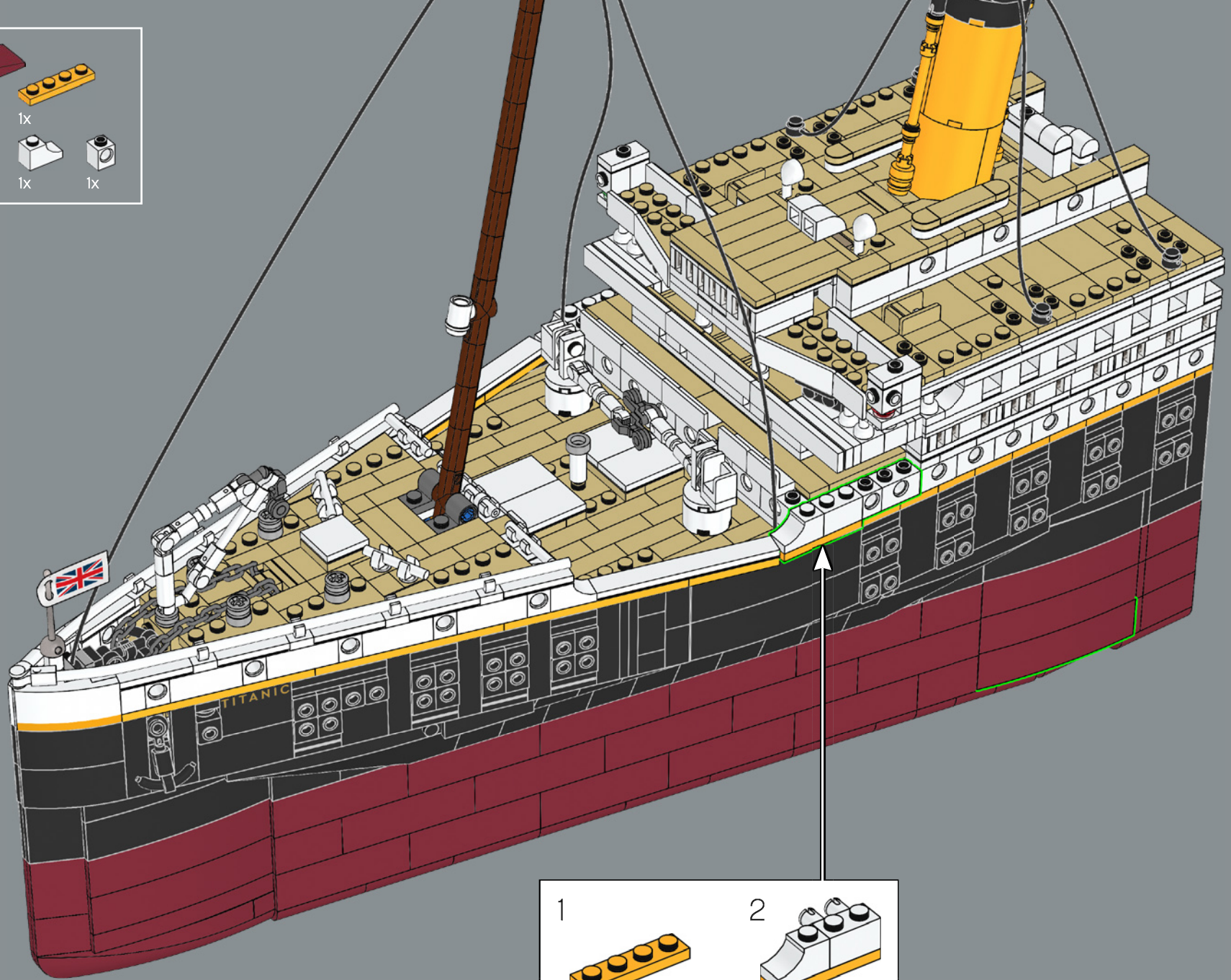

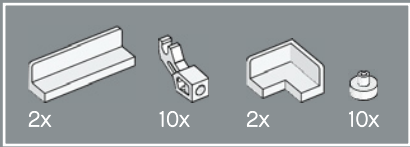

340

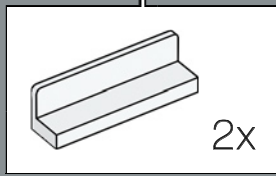
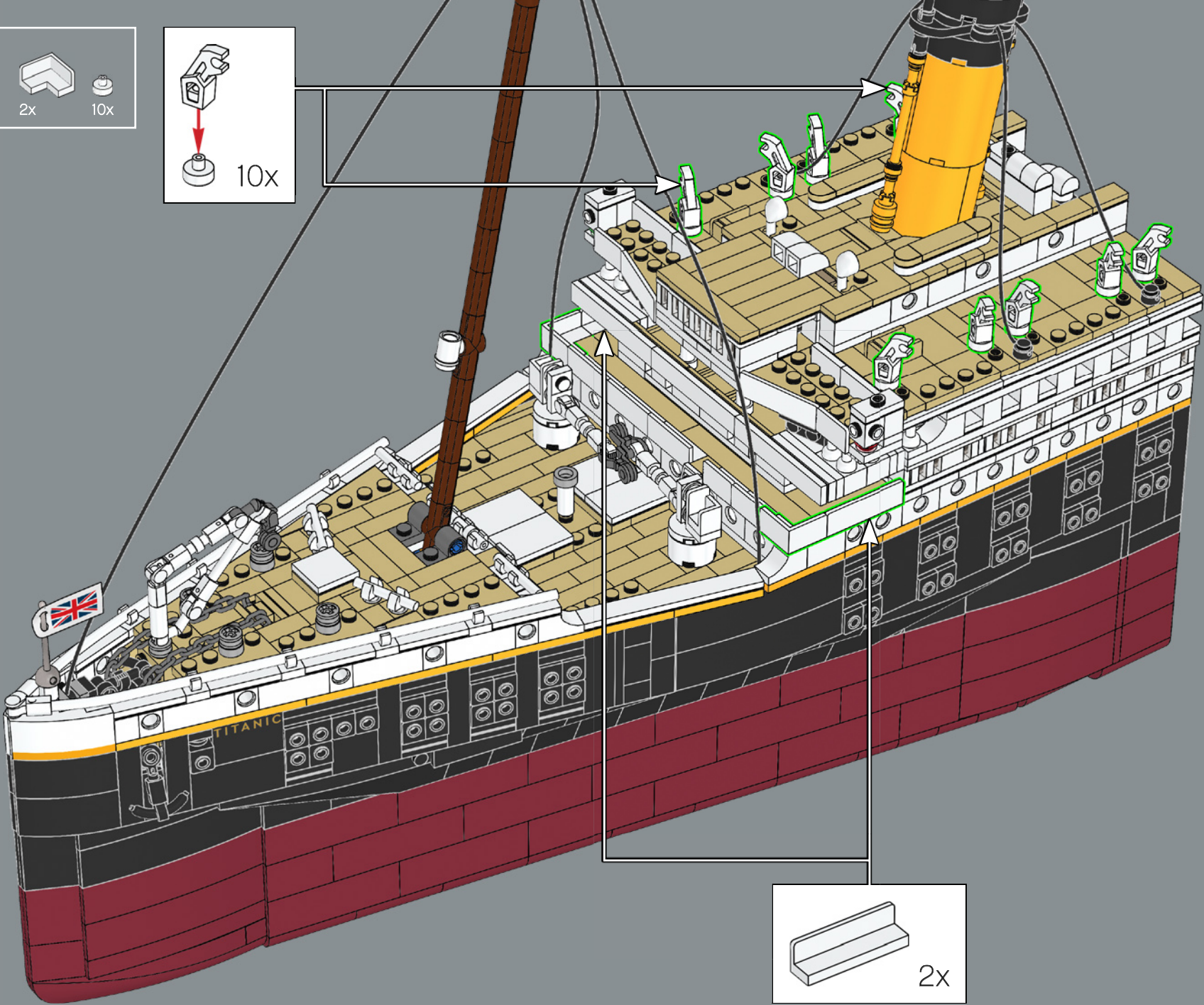
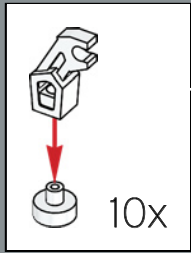



341

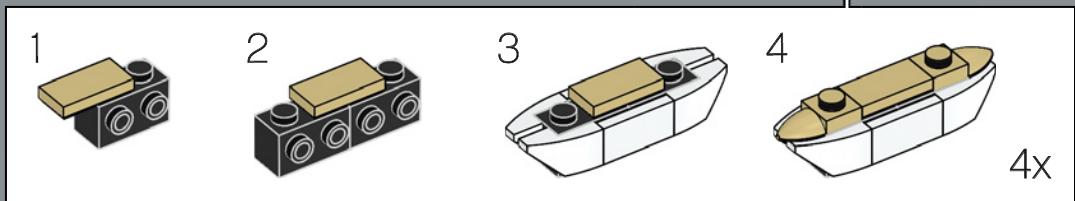
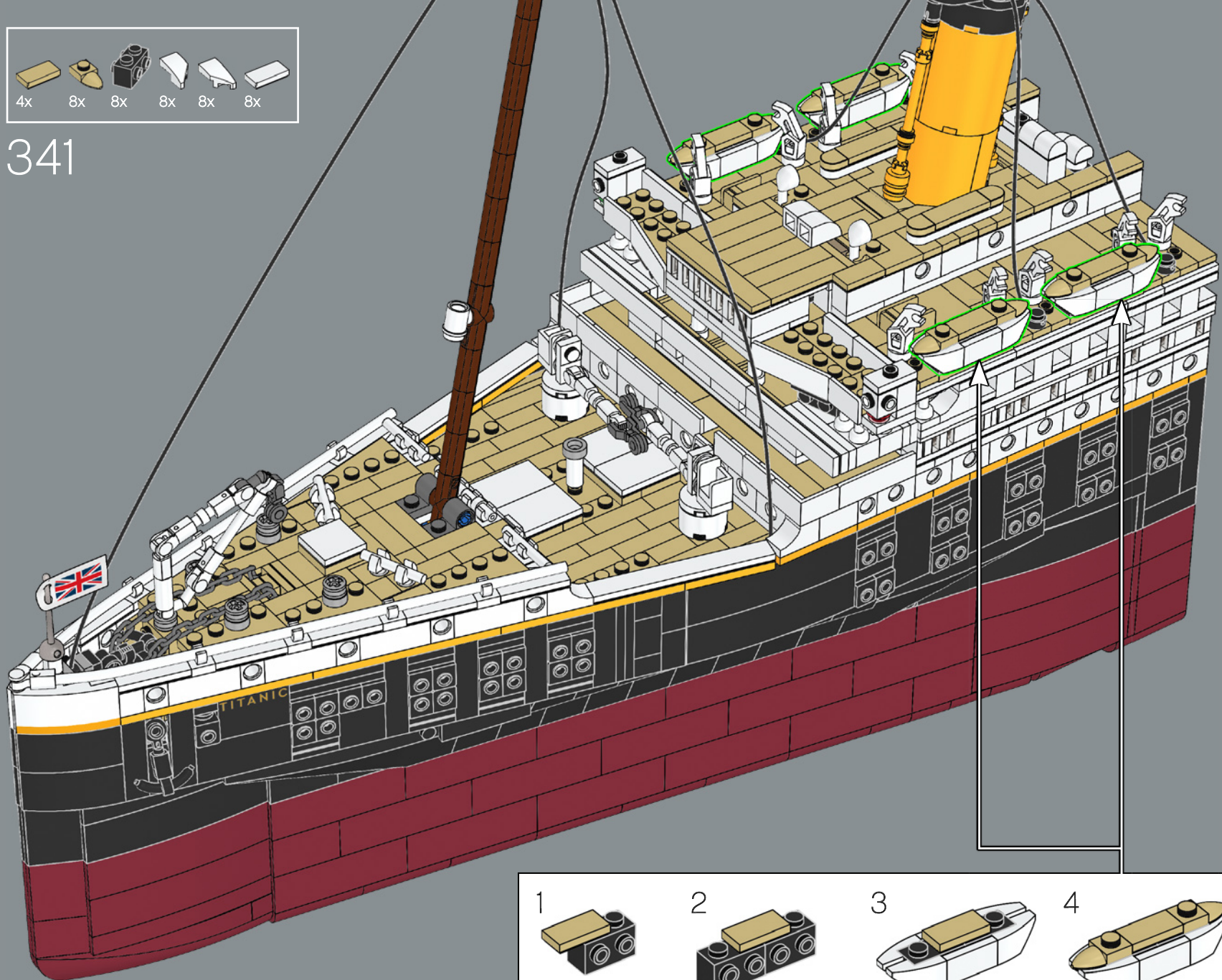

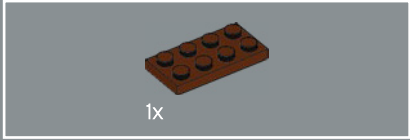
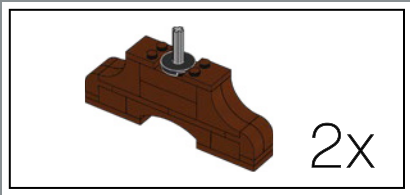

342

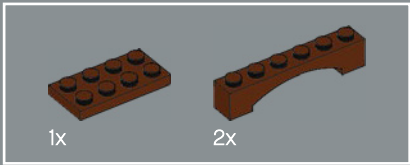
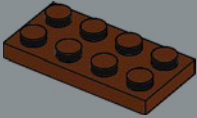

343

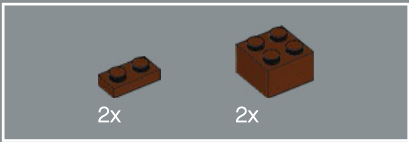
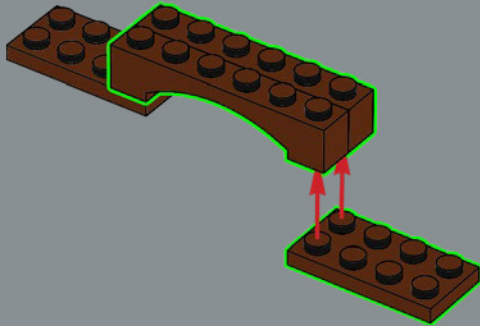

344

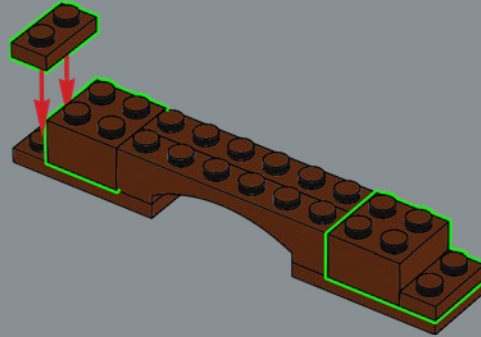

345

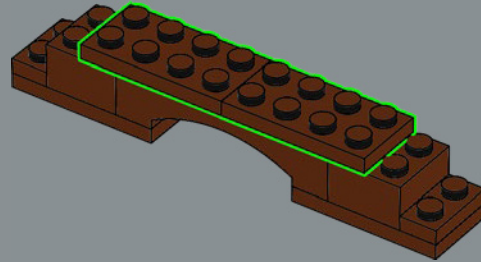

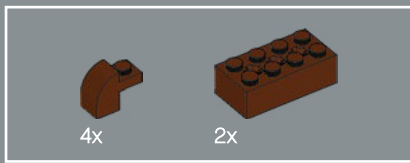

346

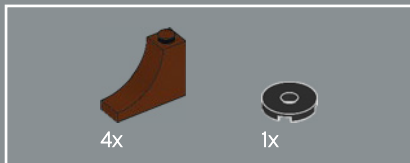
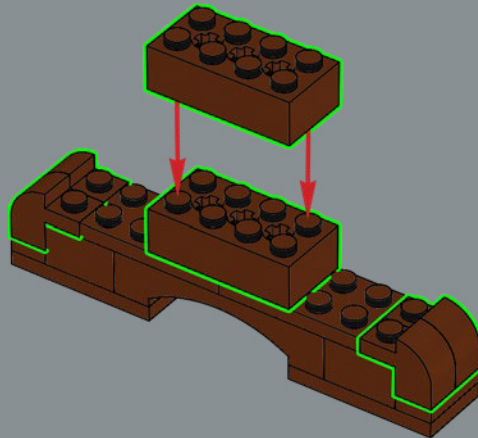

347

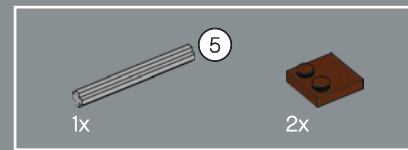
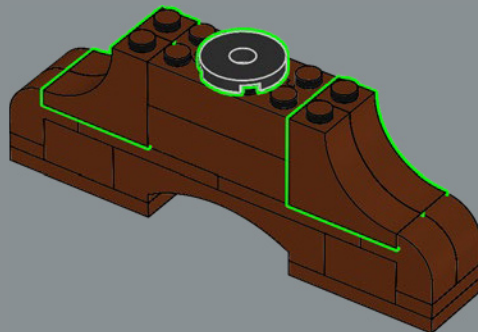

348

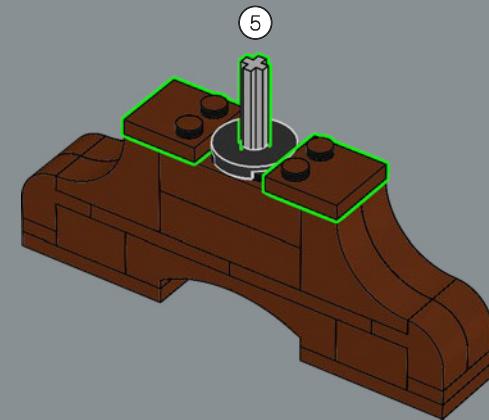

2x

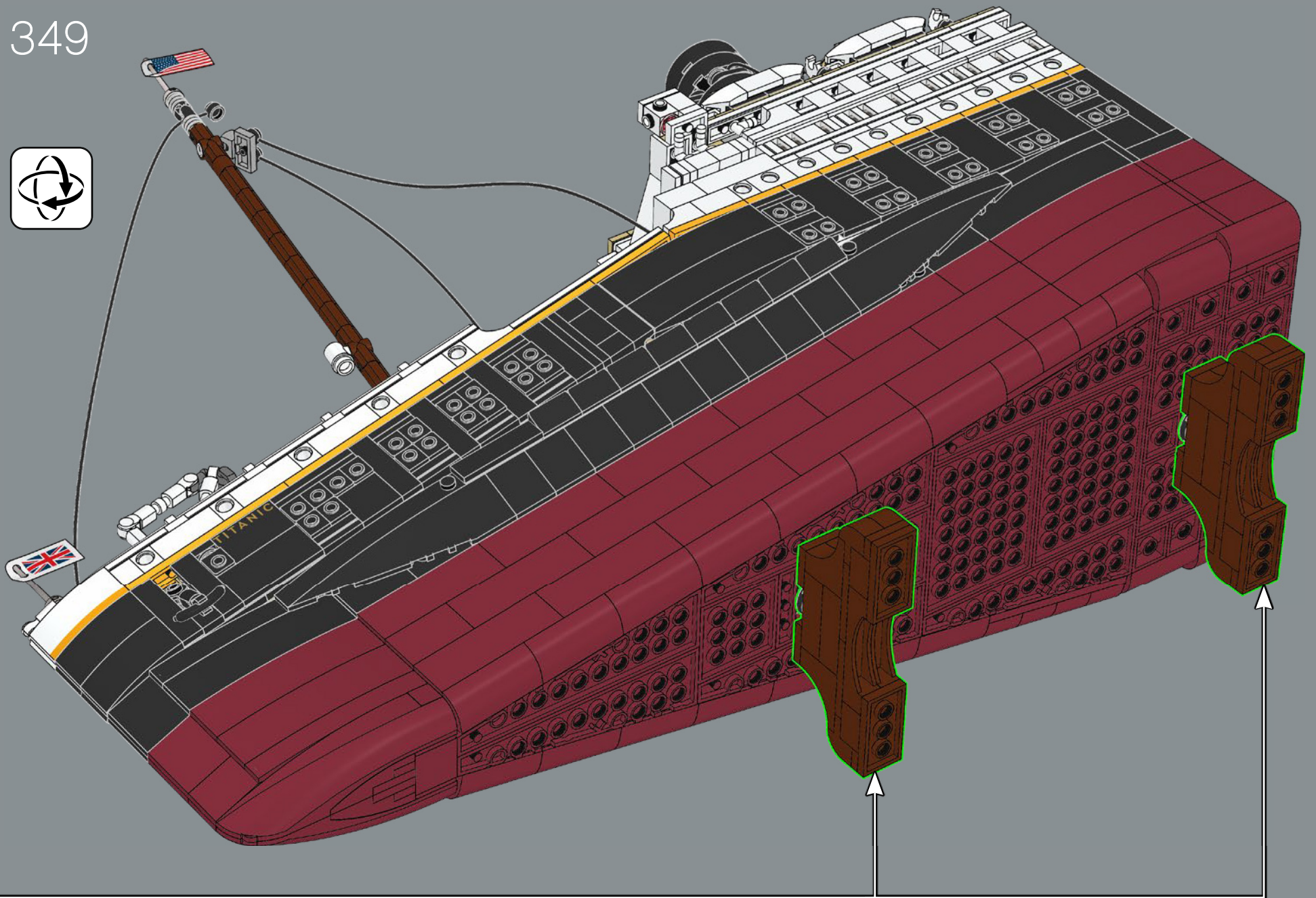

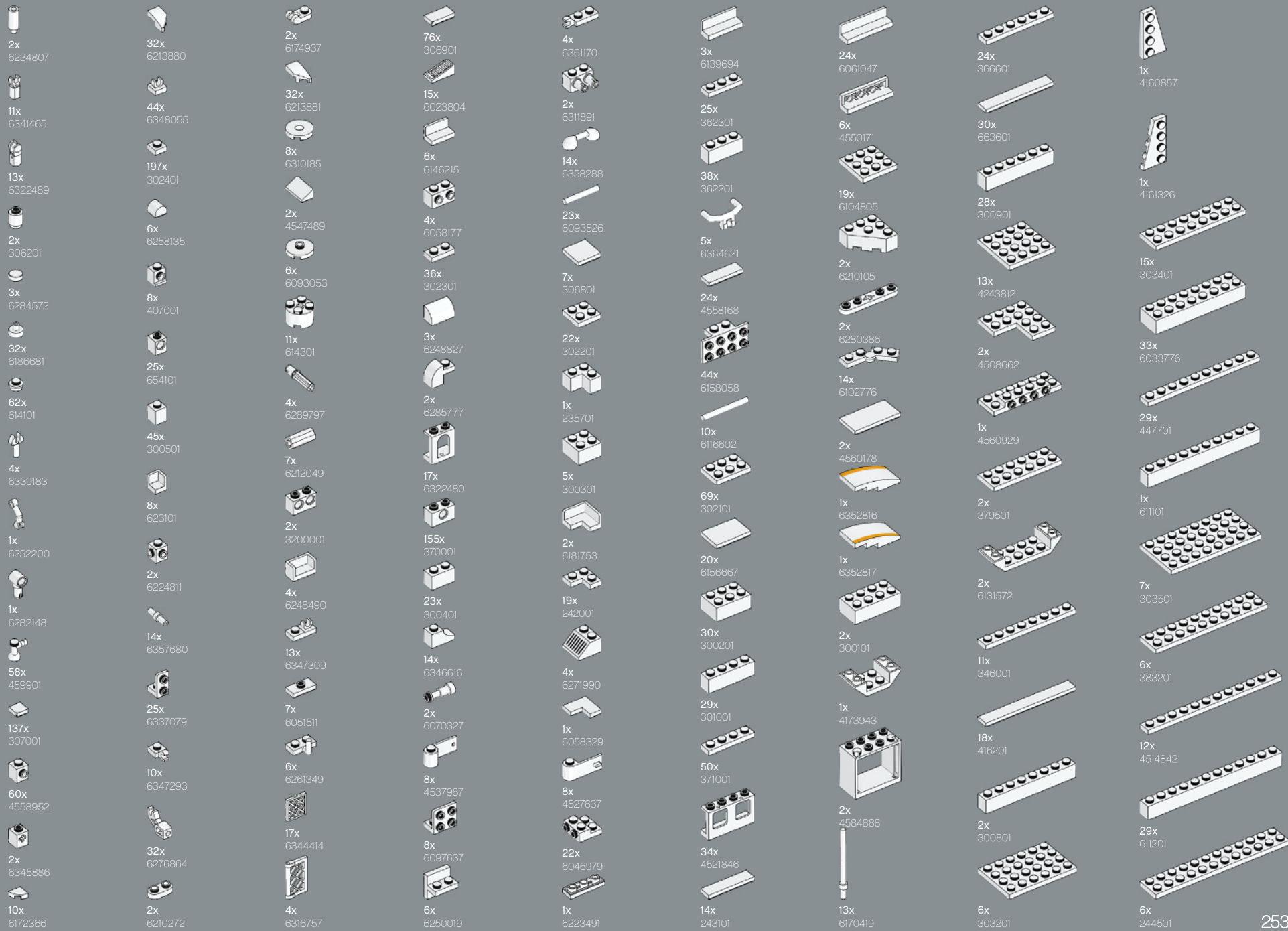

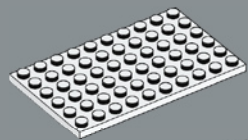

5x
4528341

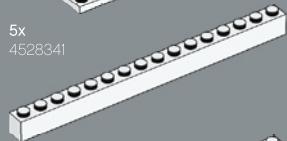

6x
246501



13x
4119227



2x
6365707

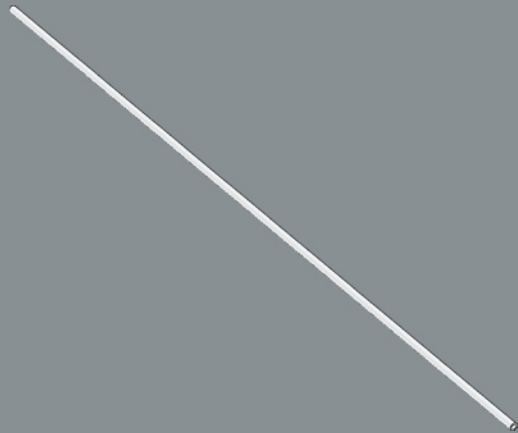

1x
6364683



1x
6370720



4x
6353196



44x
4118793



83x
6360078



2x
4113915



5x
4179771



54x
4125253



10x
4516055



20x
4159553



2x
4612603



2x
6357613



32x
4224793



4x
6355727



6x
6351413



14x
6352222



8x
6177890



8x
6177891



4x
4624086



4x
6232037



50x
4218749



41x
6092587



2x
6338180



4x
6148262



6x
4109995



6x
6146221



2x
6024495



13x
4205107



1x
6063943



2x
6294481



2x
6103001



153x
4114026



21x
4113917



20x
6034929



2x
4273526



2x
6214334



4x
6117975



4x
6249809



10x
6174925



5x
6253003



2x
6314477



2x
6358290



2x
6358290



2x
6358290



2x
6358290



2x
6358290



2x
6358290



2x
6358290



1x
4565387



39x
4185177



44x
6221467



44x
4114084



47x
6173057



18x
4114077



16x
6265572



4x
6211975



96x
6131896



14x
4121921



2x
4624088



34x
6211966



2x
6318084



8x
4118790



9x
6175367



2x
4500453



5x
4666999



2x
4113233



12x
4550324



26x
6257600



2x
6195544



2x
6115031



2x
4208072



33x
4114309



53x
6122047



8x
6351905



2x
4112982



10x
4157277

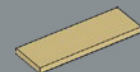

3x
6331158



4x
4113993



5x
4181134



49x
4114324



11x
4544139



12x
4159774



2x
4114001



2x
4125217



2x
4166138



3x
4509897

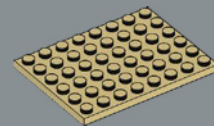

4x
6070501

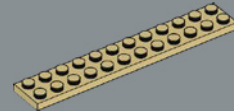

6x
6093864



6x
6284574



2x
306221



8x
654121



10x
6345429



1x
6210269



46x
4142865



2x
6168634



4x
6019155



1x
6265697



22x
302321



2x
245821



2x
6313831

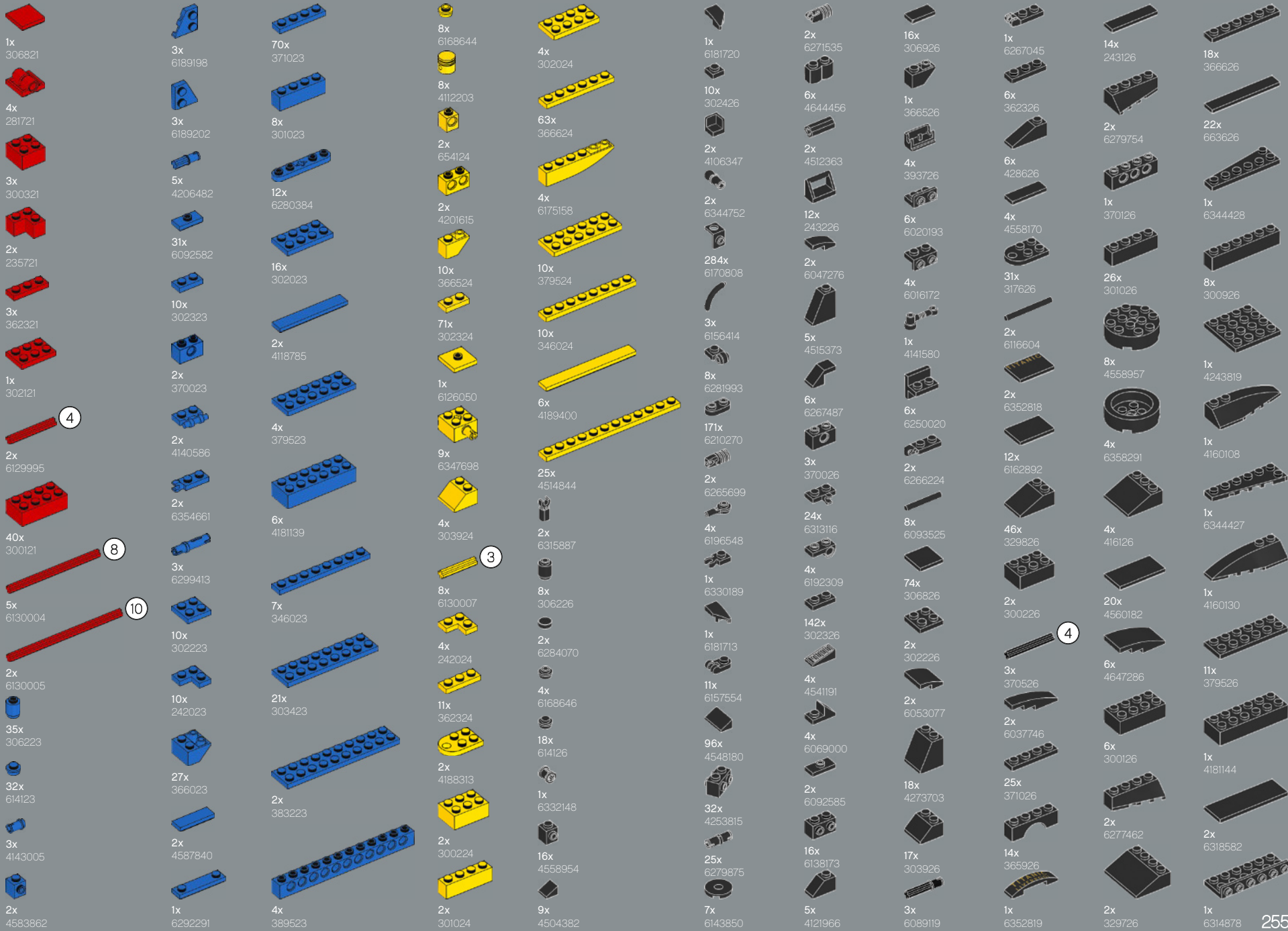

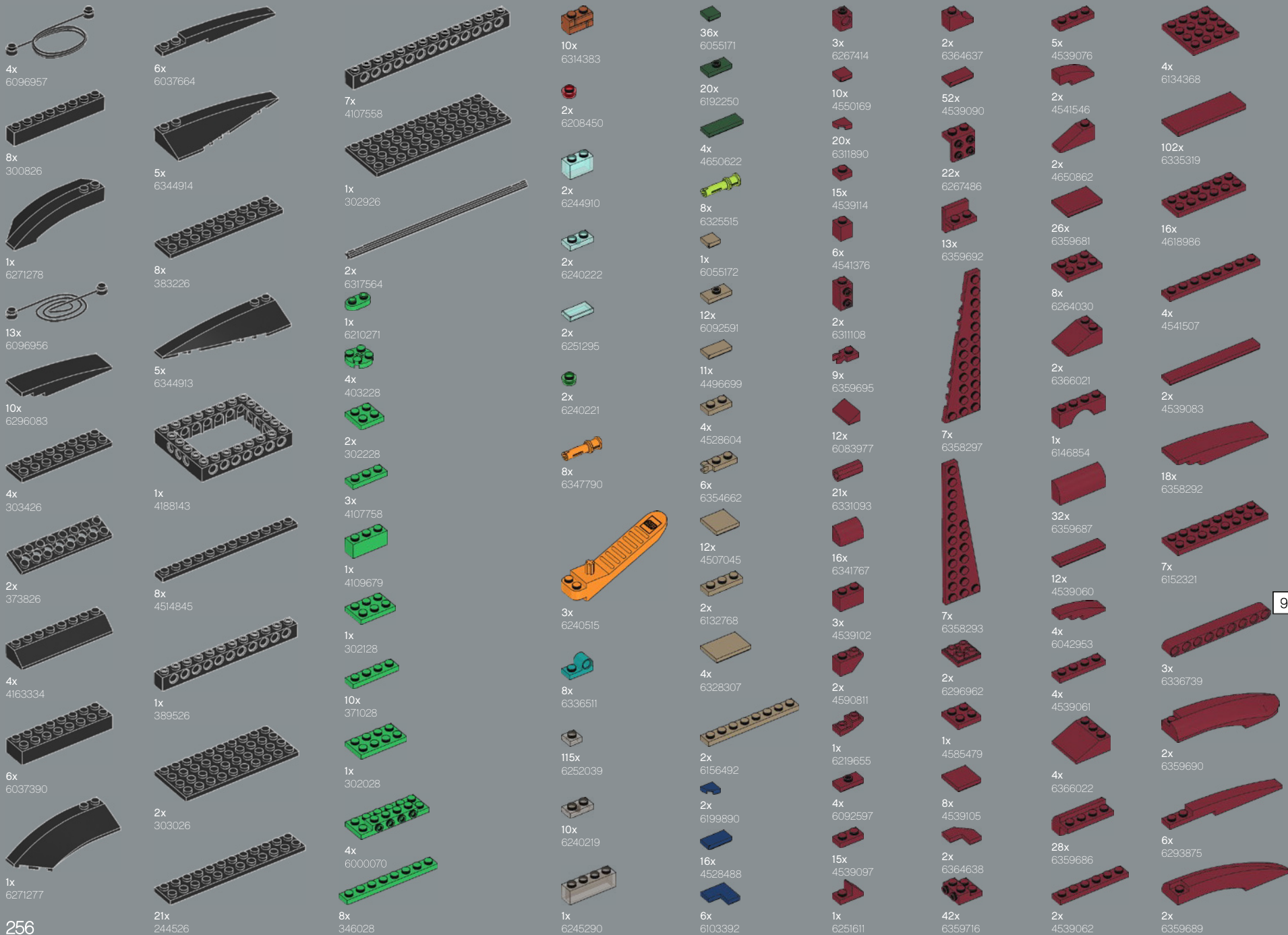

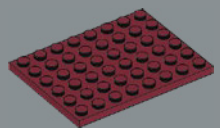

11x
6028115

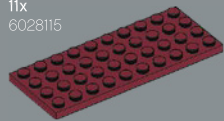

8x
6186106



8x
6245265



16x
6134252



8x
6223719



16x
6331261



6x
6073040



6x
6028736



91x
6097503



16x
6358295



16x
6020073



4x
6359223



12x
6020074



9x
6192205

6x
4211183



19x
4216581



1x
6170813



2x
6149677



12x
4221744



26x
4211288



46x
4225469



4x
6325717



29x
4531751



2x
4211222



2x
4211252



1x
4211252



14x
6365885



105x
4211150



24x
6365567



1x
4211151



10x
6365884



24x
4645103



39x
6236915



20x
6196221



30x
4211210



10x
6365883



5x
6333110



6x
4211220



20x
4211152



24x
6133833



9x
6172636



30x
4211186



14x
6365882



1x
4221590



18x
4211193



12x
4655611



1x
4216615



6x
6313736



2x
4211211



2x
4222627



1x
6338230

88x
4211412

23x
6258831

7x
6172165

1x
4211483

3x
4558953

12x
4211399

2x
6225242

2x
6345639

8x
6335378

8x
4211375

8x
4211375

4x
4568637

2x
6352979

2x
6352983

1x
6352986

1x
6352997

1x
6353001

155x
4550325

2x
6372076

16x
6093859

4x
6327412

9x
6338165

2x
4211564

20x
4211398

8x
4211414

8x
4211440

10x
6206249

1x
6326078

8x
6146300

8x
4211363

4x
4211494

2x
4211614

4x
6117967

6x
4654580

8x
4211609

4x
6337268

4x
6078211

4x
6198932

4x
4667578

4x
4211461

4x
4211632

4x
6321743

4x
4208988

1x
4209006

8x
4211397

46x
6212077

6x
6007894

6x
4234535

4x
4211815

4x
6078212

8x
6195471

1x
6346487

4x
6326483

1x
6304930

15x
6211969

8x
4211419

11x
4211773

30x
4211396

1x
4211386

9x
4211394

1x
4211441

2x
4211445

26x
4211636

8x
6230229

2x
4211361

2x
4211395

8x
4211385

6x
4211639

4x
6256117

8x
6105964

6x
4211393

16x
4211438

2x
4612621

2x
4211837

2x
4527174

4x
6015349

35x
4211452

13x
4211795

4x
6225219

4x
4211425

2x
4211442

3

5

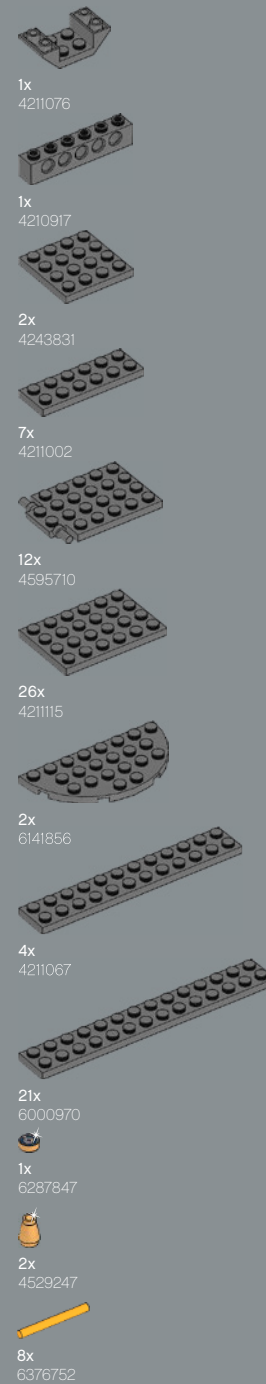
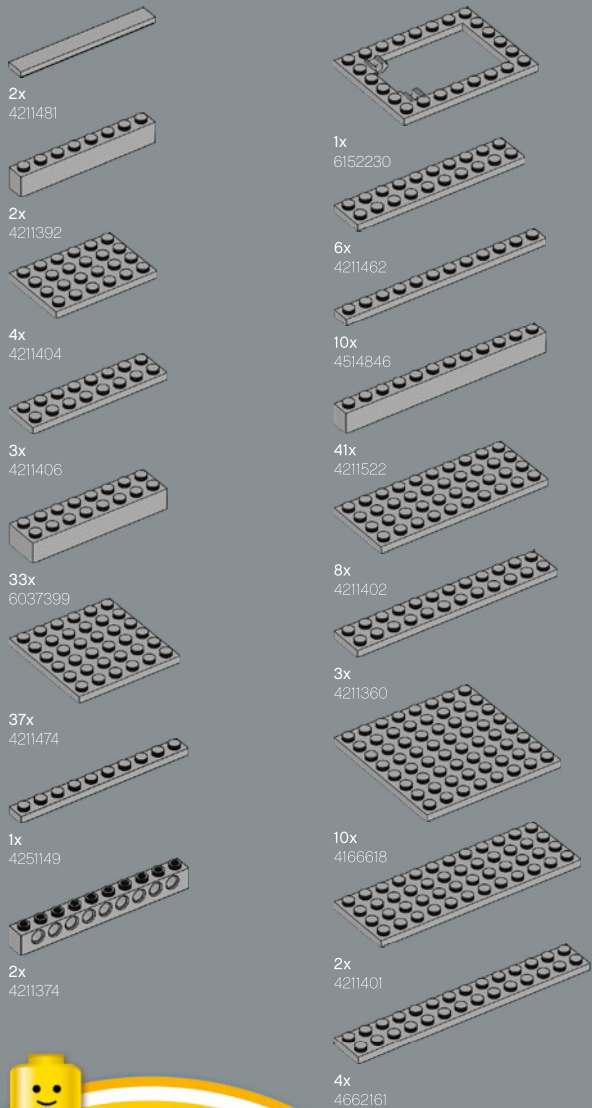

Customer Service
Kundenservice
Service Consommateurs
Servicio Al Consumidor

LEGO.com/service or dial





FEEDBACK AND WIN



FEEDBACK AND WIN

Your feedback will help shape the future development of this product series.

Please visit:

FEEDBACK UND GEWINNEN

Dein Feedback trägt zur Weiterentwicklung dieser Produktreihe bei.

Geh auf:

COMMENTEZ ET GAGNEZ

Vos commentaires nous aideront à concevoir les futurs produits de cette gamme.

Rendez-vous sur :

COMENTA Y GANA

Tu opinión nos ayudará a dar forma al desarrollo de esta serie de productos en el futuro.

Visita:

反馈有奖

您的反馈将有助于我们在今后改进本系列产品。

请访问：

[LEGO.com/productfeedback](https://www.lego.com/productfeedback)

By completing, you will automatically enter a drawing to win a LEGO® set.

Terms & Conditions apply.

Durch Ausfüllen nimmst du automatisch an der Verlosung eines LEGO® Preises teil.

Es gelten die Teilnahmebedingungen.

En envoyant vos commentaires, vous serez automatiquement inscrit(e) à un tirage au sort qui vous permettra de remporter un prix LEGO®.

Offre soumise à conditions.

Al contestar, participarás automáticamente en el sorteo y podrás ganar un set LEGO®.

Sujeto a Términos y Condiciones.

完成我们的反馈调查，即可自动进入抽奖环节，赢取乐高®套装。

适用《条款和条件》。

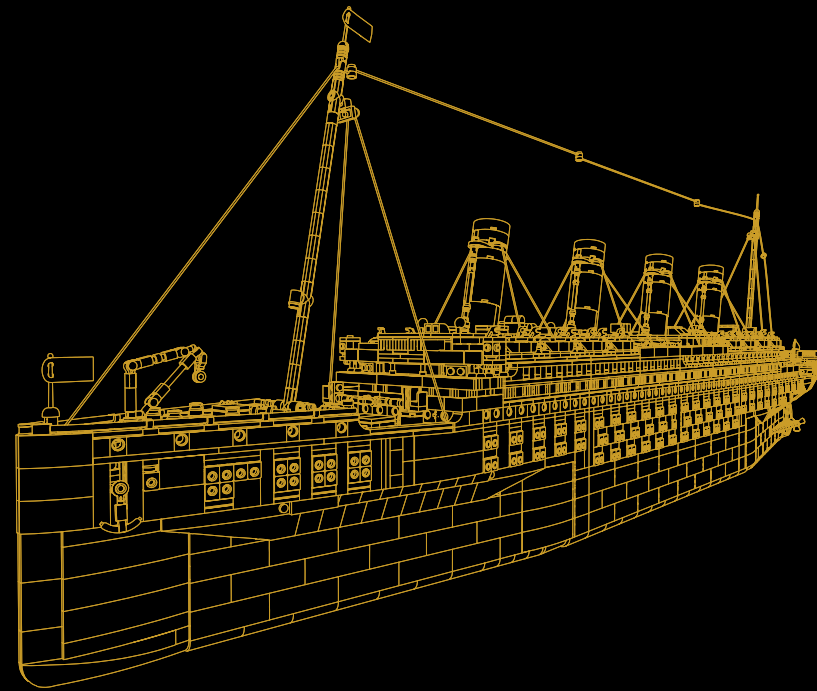

LEGO and the LEGO logo are trademarks of the LEGO Group. ©2021 The LEGO Group.