

LE TITANIC

LIVRET 2

LE PAQUEBOT LE PLUS LUXUEUX AU MONDE

Conçu pour être l'incarnation de l'élégance, du confort et du luxe, le Titanic donne l'impression d'être un hôtel flottant plutôt qu'un navire. Il offre à ses 833 passagers de première classe une vaste gamme d'installations, dont un gymnase, un terrain de squash, une piscine, des bibliothèques, des restaurants raffinés et de magnifiques cabines. L'élément le plus caractéristique du navire est le grand escalier, construit en chêne massif, qui traverse majestueusement les sept ponts du paquebot.



↑ L'escalier arrière de première classe, menant au restaurant à la carte.

→ Menu du dîner de 2e classe daté du 14 avril 1912, date à laquelle le Titanic heurte l'iceberg qui le fait couler.

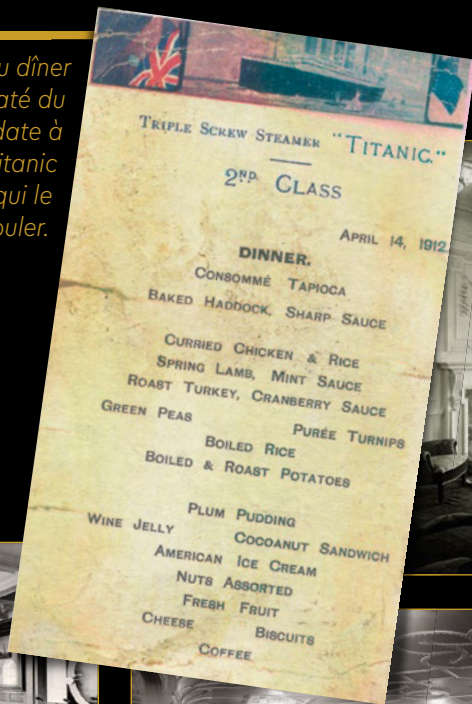

↓ Salle de lecture sur la promenade supérieure.



↓ Le salon de la première classe.



↓ Le gymnase de la première classe.



↑ Salle à manger principale.



↑ Le Café Parisien, un prolongement du restaurant de la première classe.



↑ L'élégante et splendide cabine de la première classe B57.

LA CONSTRUCTION DU TITANIC

Ce qui n'était au départ qu'un modèle conceptuel réalisé lors d'une séance de construction libre pour les designers LEGO® est rapidement devenu l'un des plus grands sets LEGO jamais créés. Sa taille impressionnante n'a cependant jamais été le but premier. Ses dimensions se sont accrues au fur et à mesure de l'ajout d'une foule de détails complexes par les designers, qui les considéraient comme nécessaires. Selon le designer LEGO chevronné Mike Psiaki, il fallait recréer des machines à vapeur à pistons mobiles avec des pièces LEGO Technic. Une fois le design initial achevé, l'équipe a passé une semaine entière à construire différentes versions du modèle et à délibérer sur les éléments à améliorer ou à simplifier.



↑ Quelques membres de l'équipe LEGO® ayant travaillé sur ce modèle (de gauche à droite) : Senior Model Coach, Torben Kilde Skov, Design Master, Mike Psiaki, Senior Building Instruction Specialist, Martin Højen Holm Buk

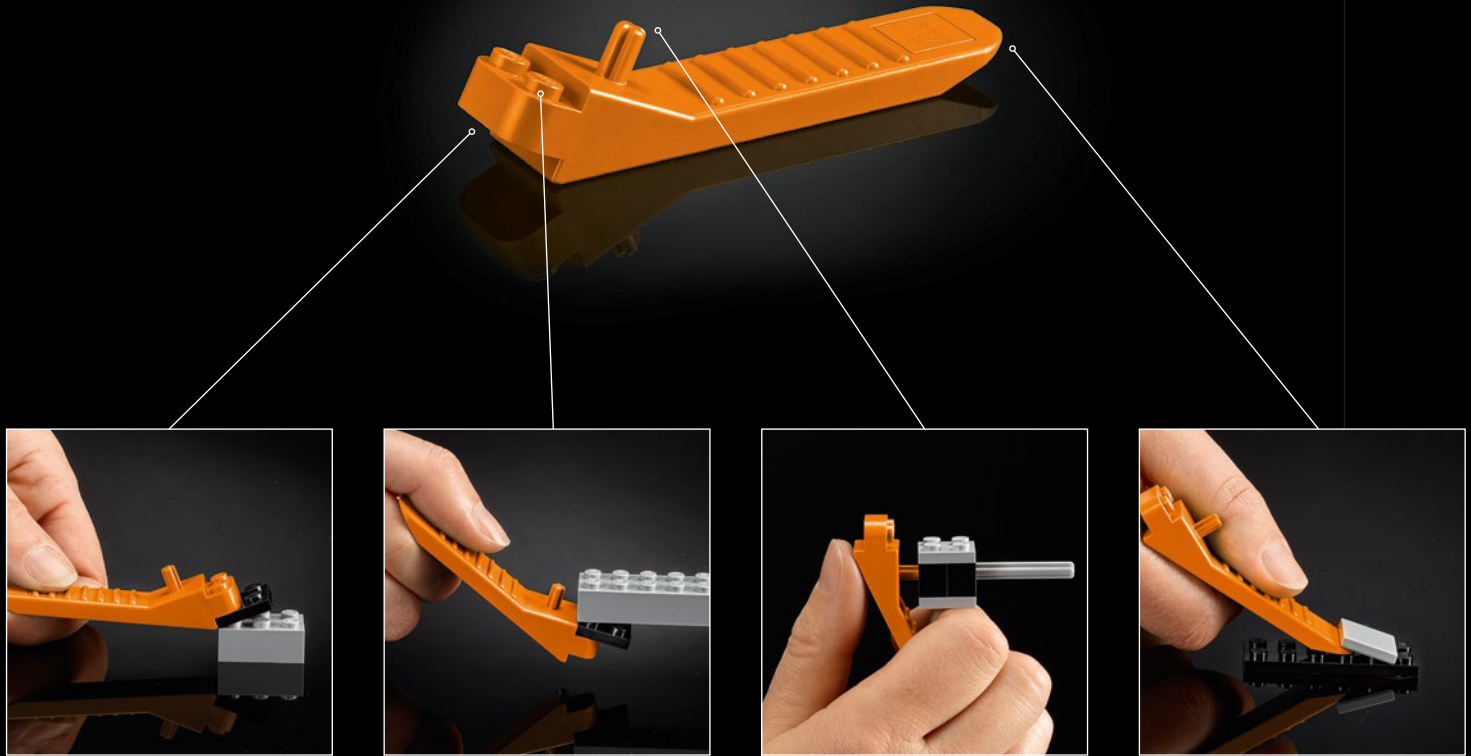

[LEGO.com/brickseparator](https://www.lego.com/brickseparator)

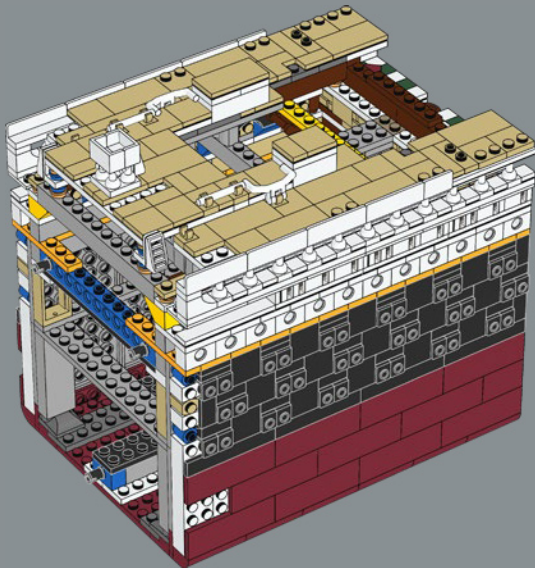
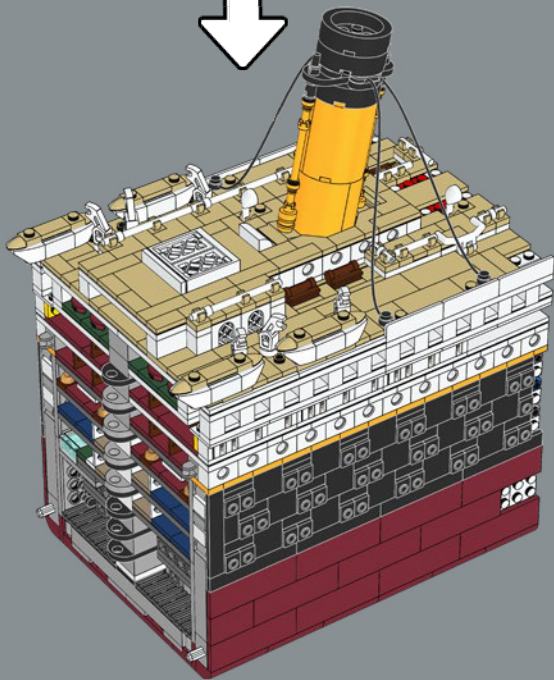

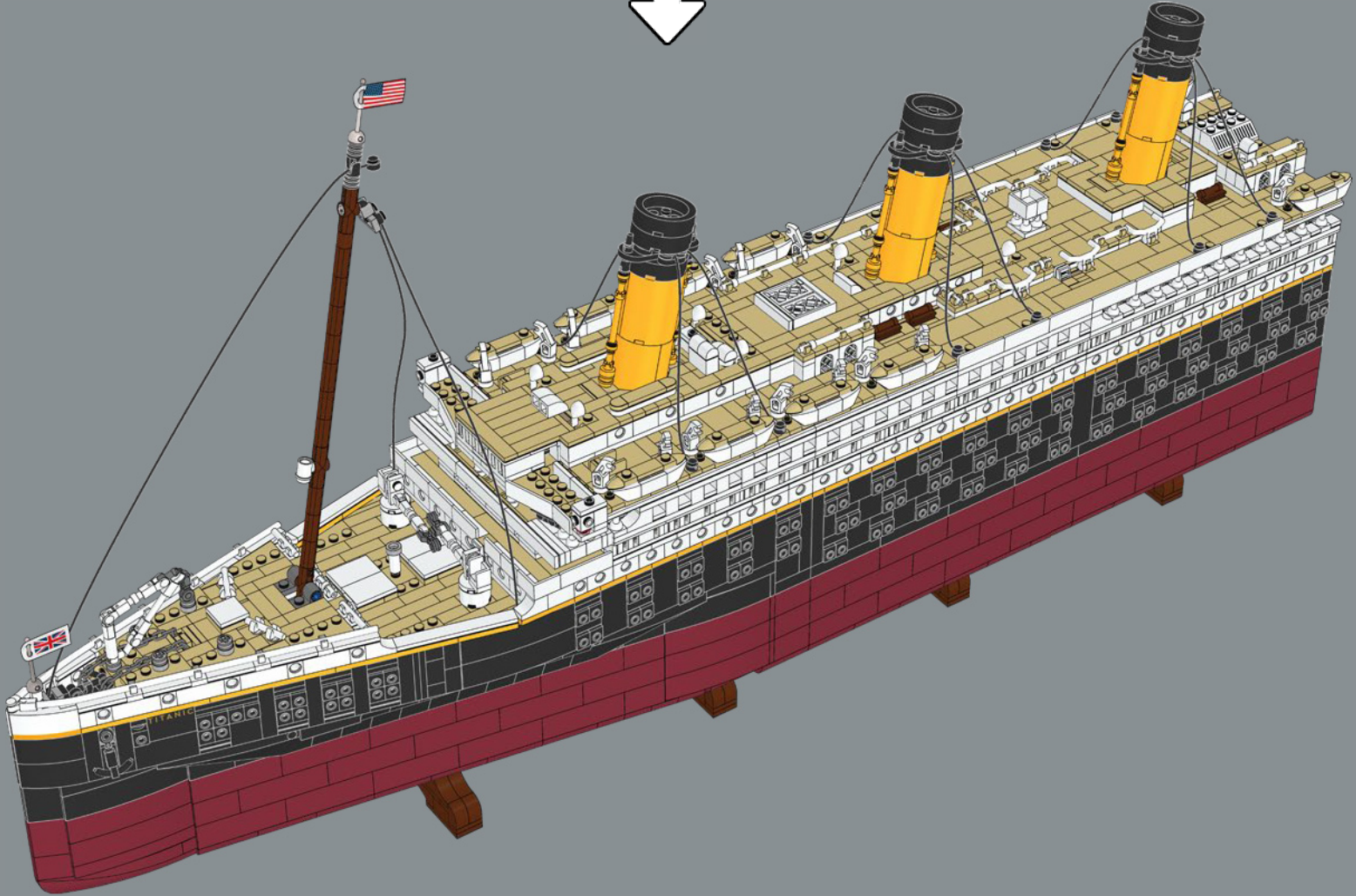
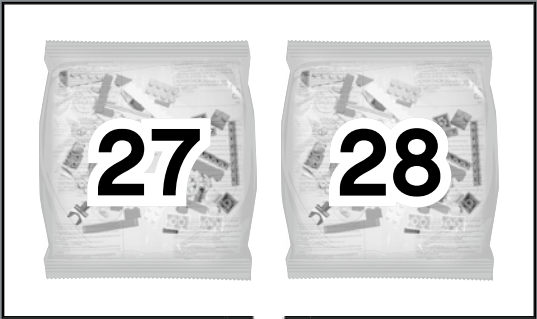

↓ Cette section permet de construire la deuxième moitié du mécanisme de verrouillage qui maintient les 3 sections principales du navire ensemble.

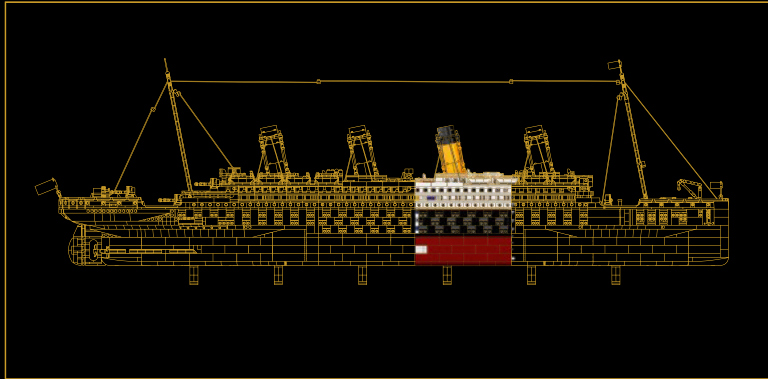

SECTION 3 :

CHEMINÉE ET CABINES PRINCIPALES

Vous construirez ici une autre section transversale du navire, comprenant quelques-unes des soutes à charbon dans les ponts inférieurs et de nombreuses cabines de différentes classes. La superstructure de cette section contient les débuts des ponts promenade du navire ainsi que le puits de lumière pour le grand escalier et la deuxième cheminée.



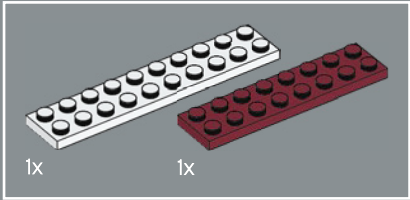
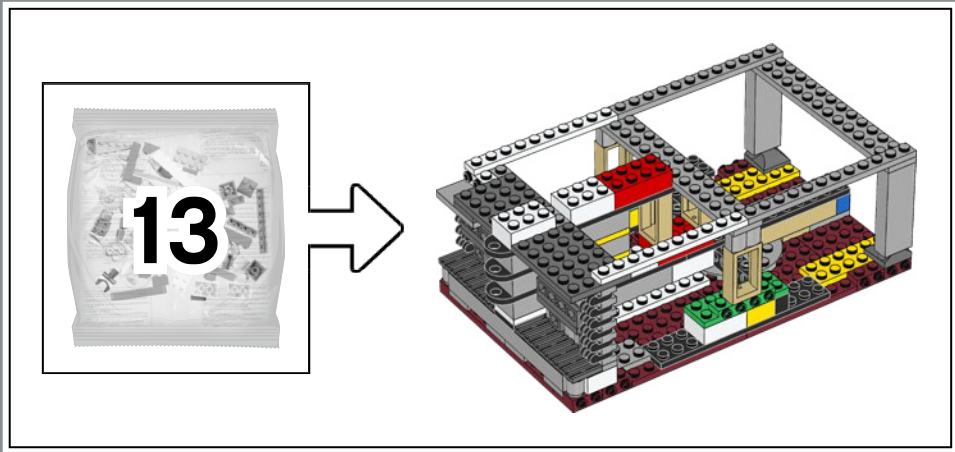

1

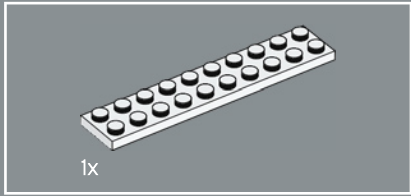
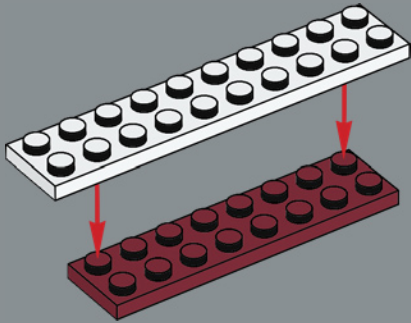

2

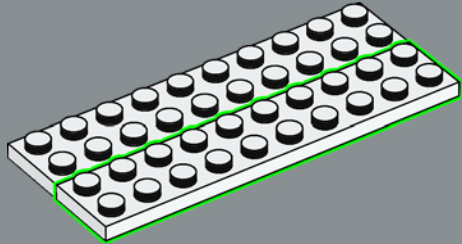

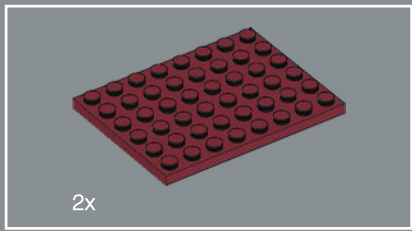

3

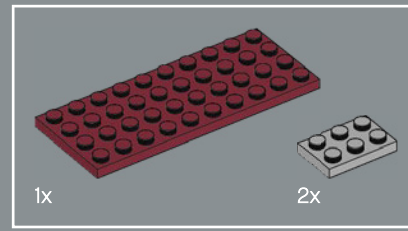
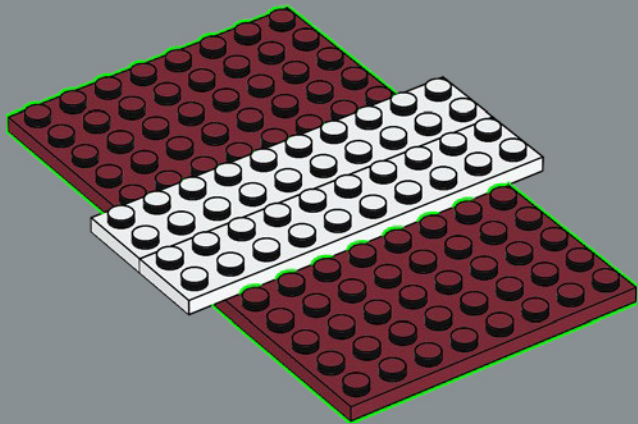

4

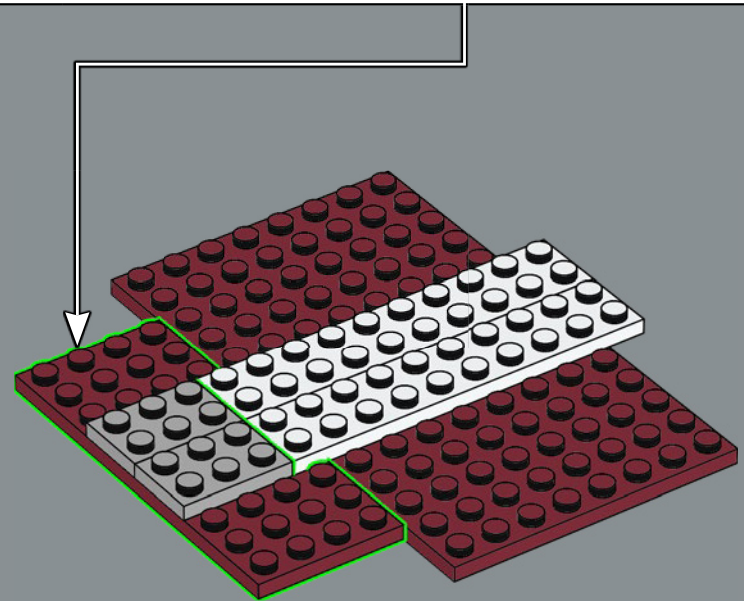
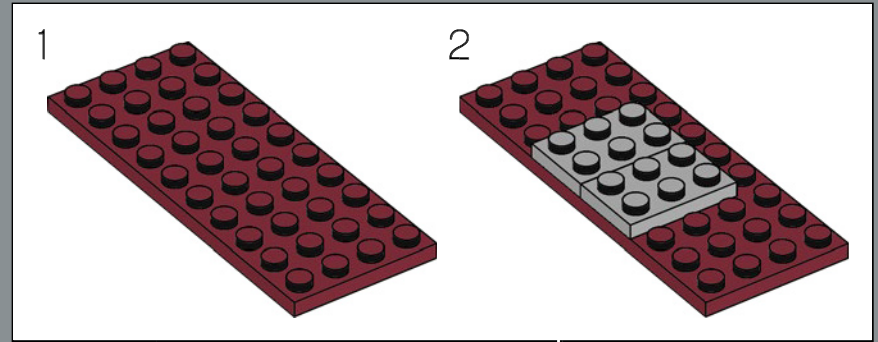

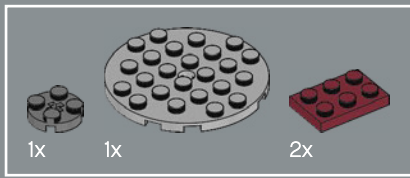

5

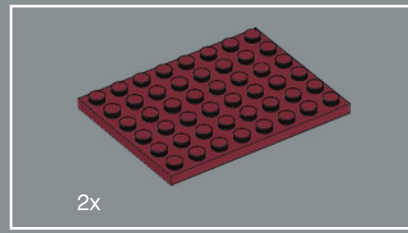
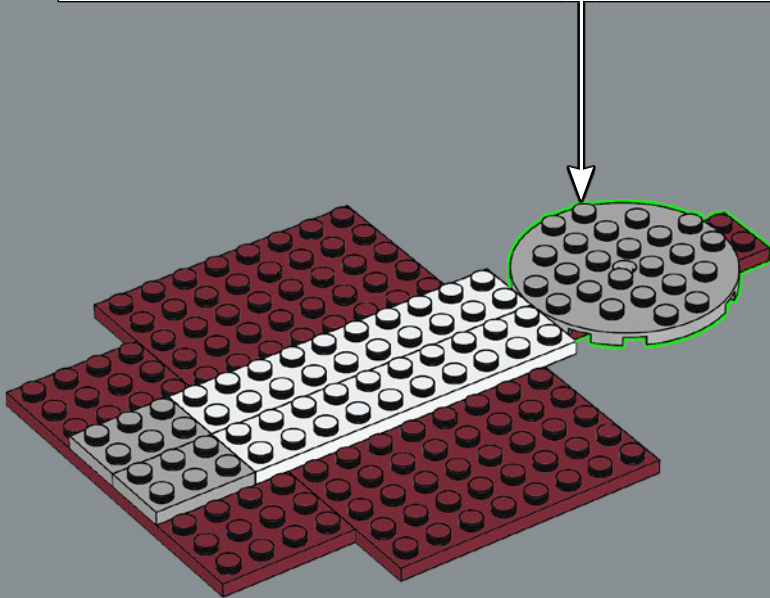
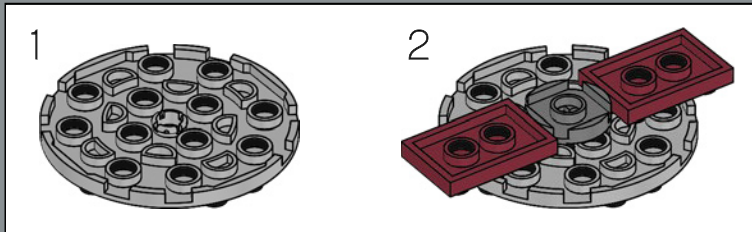

6

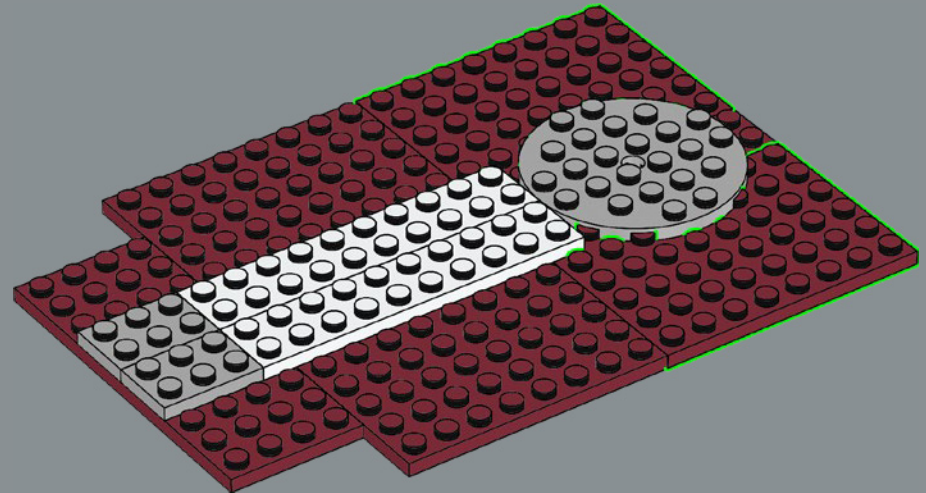

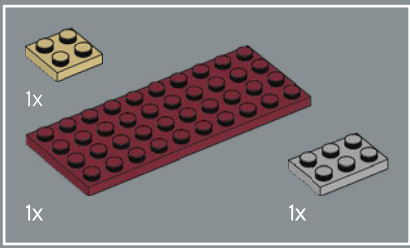

7

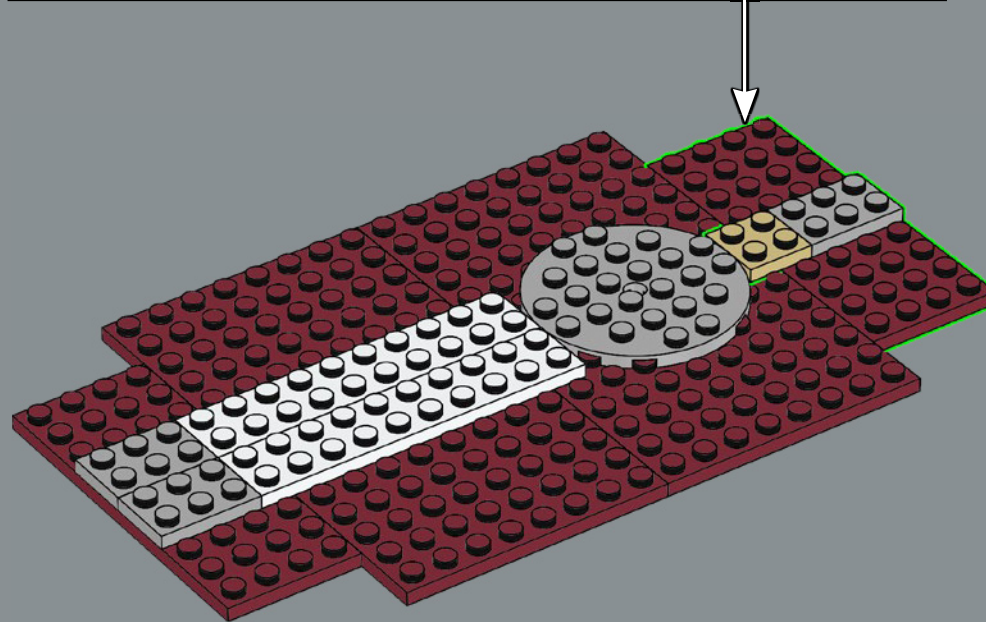
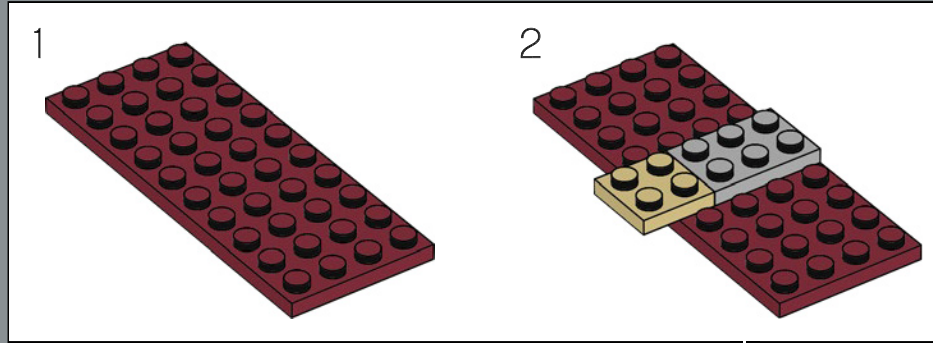

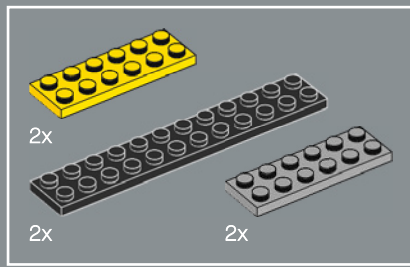

8

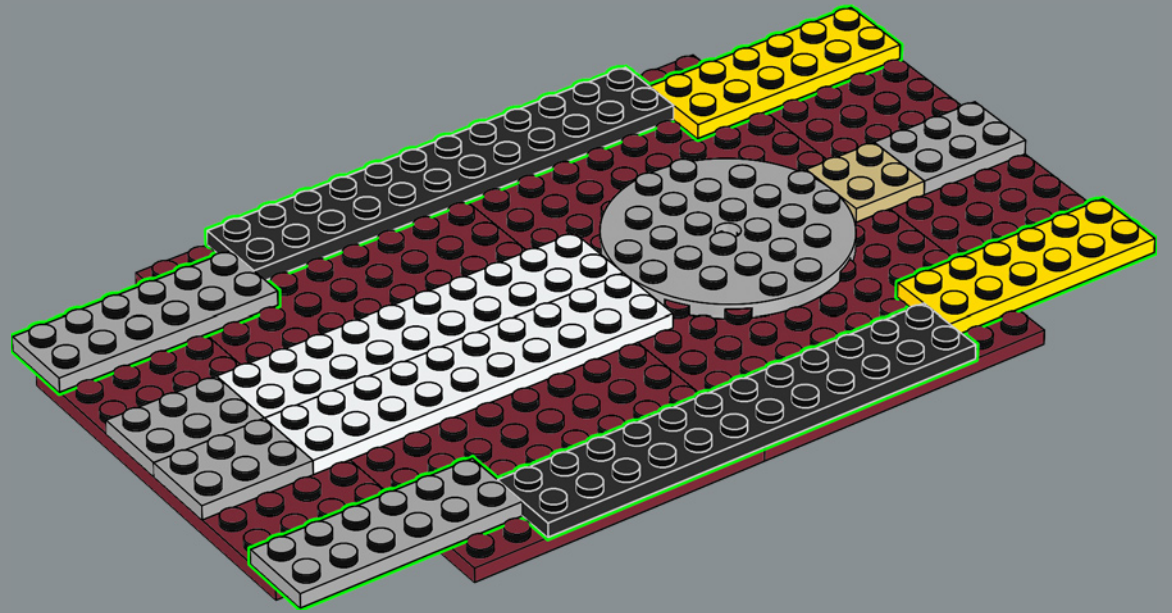

9

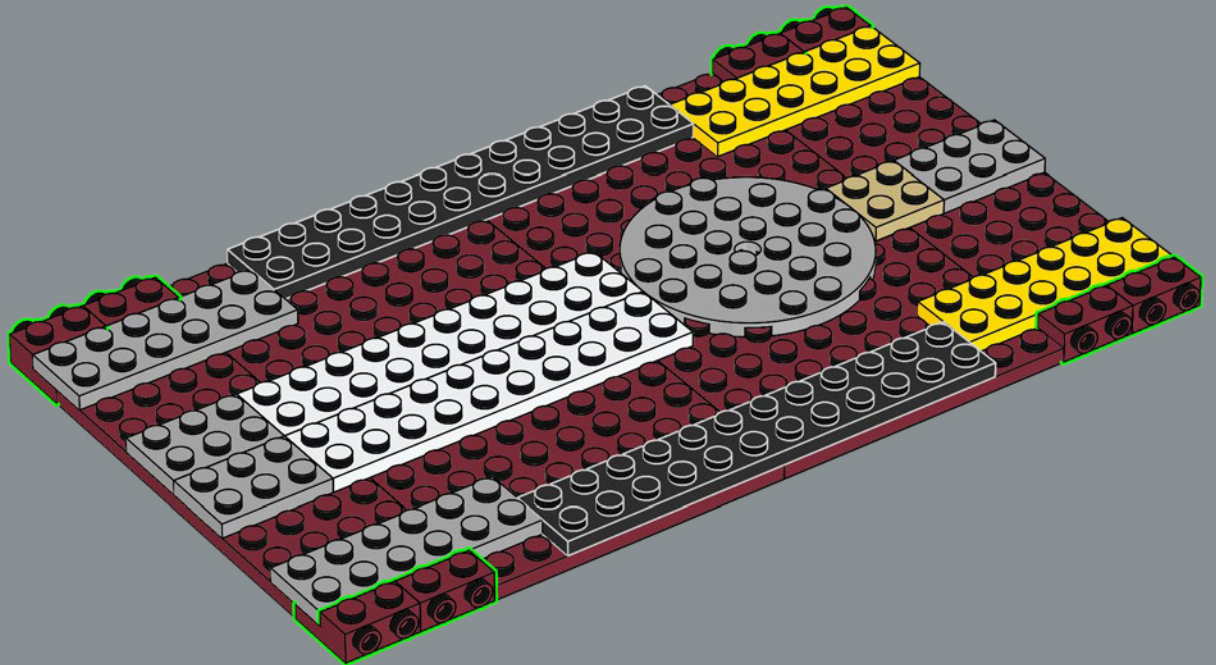

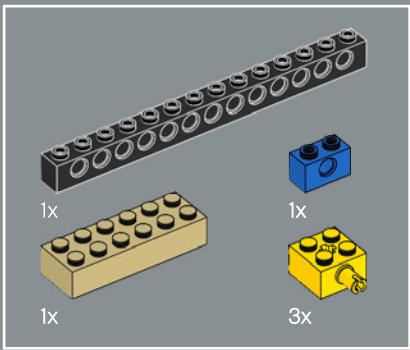

10

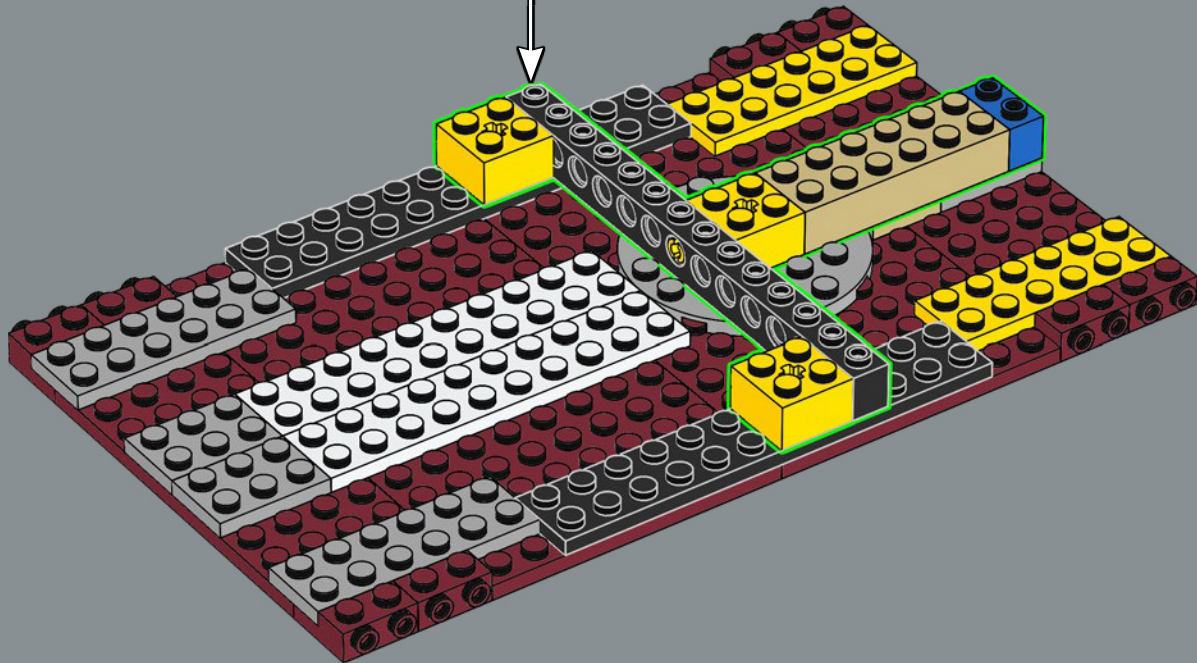
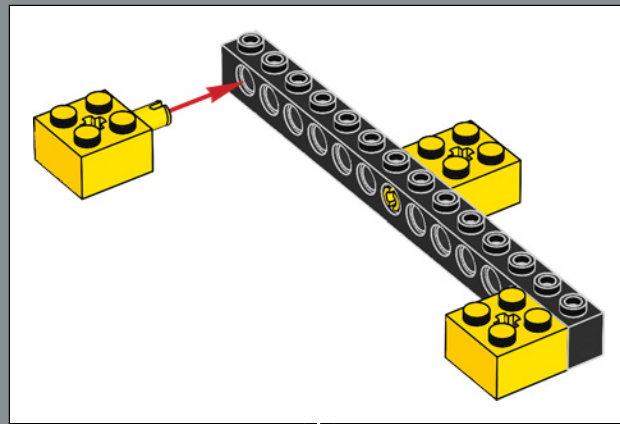

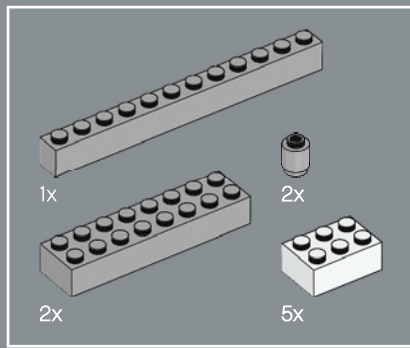

11

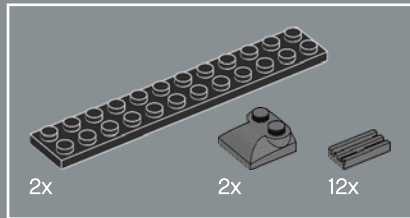
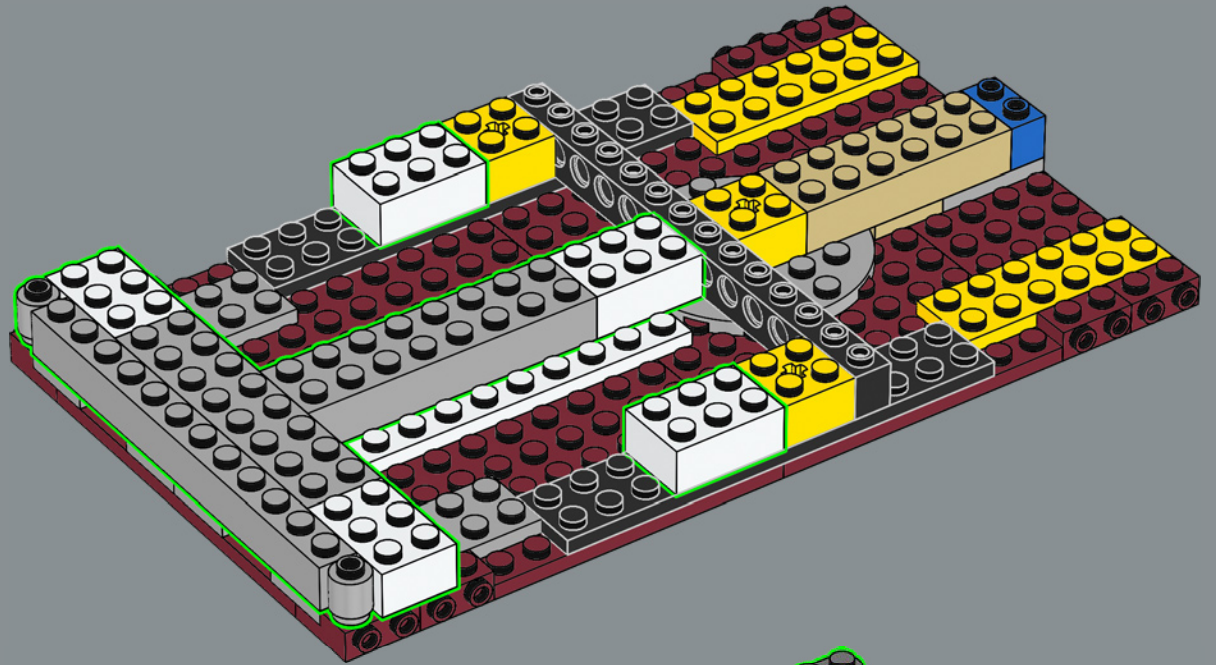

12



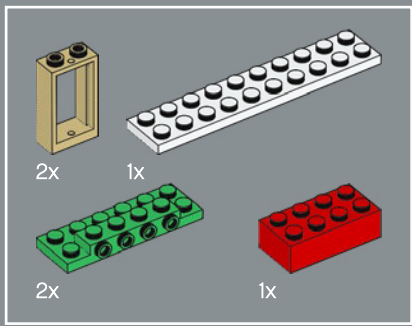

13

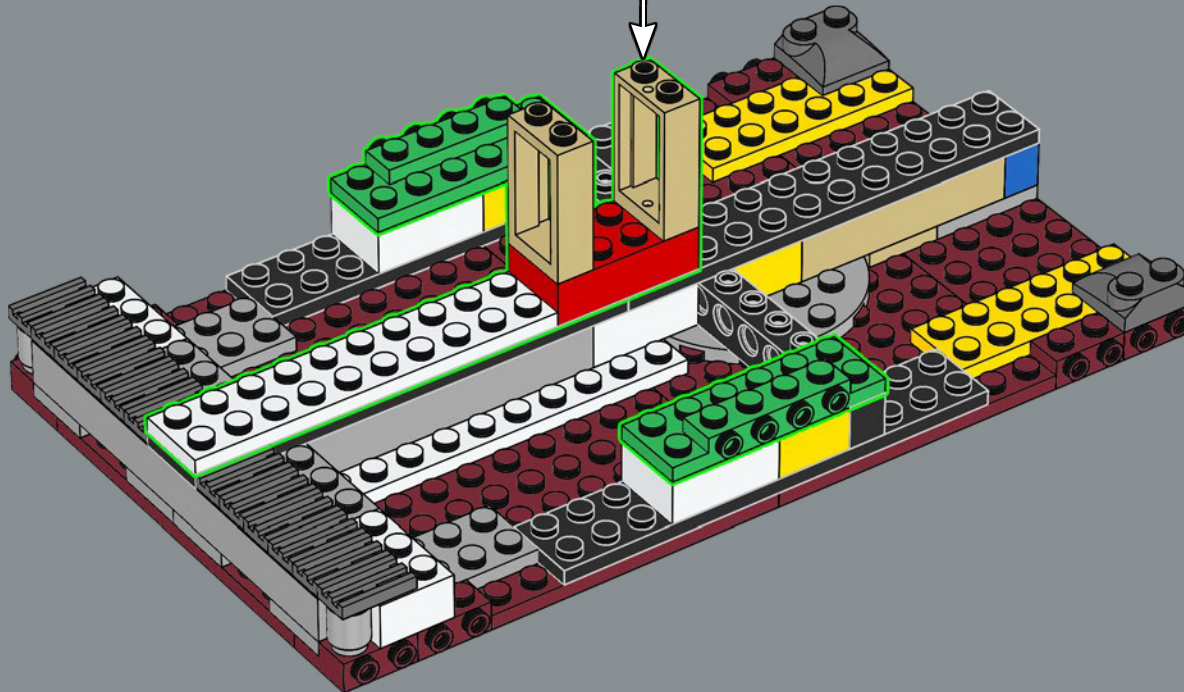
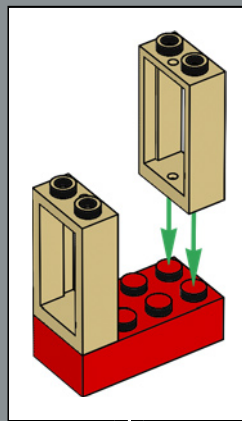

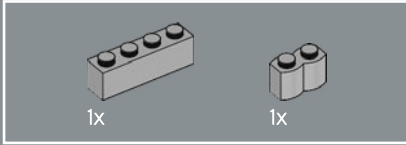
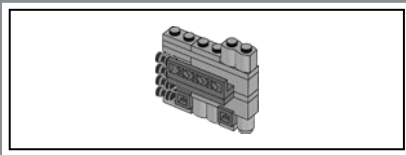

14

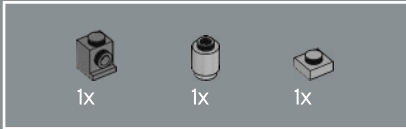
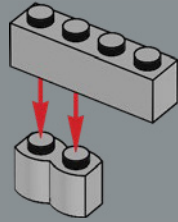

15

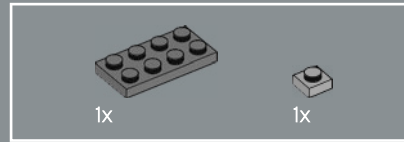
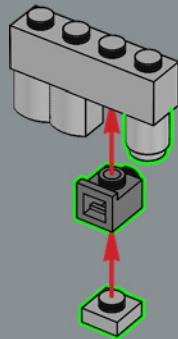

16

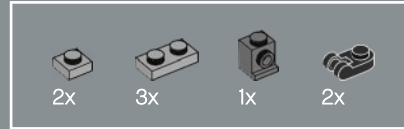
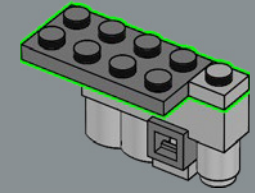

17

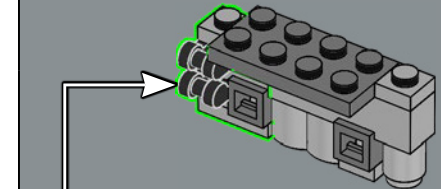
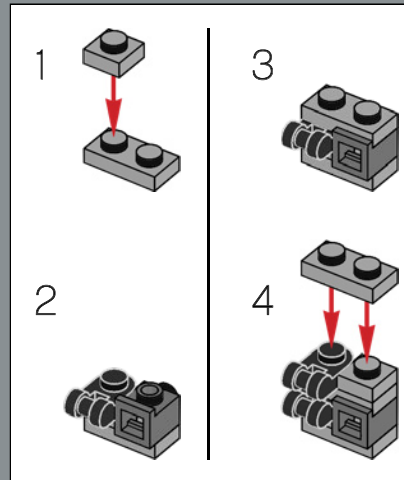



18

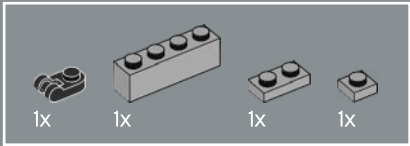
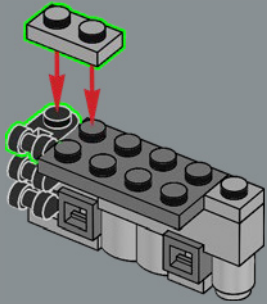

19

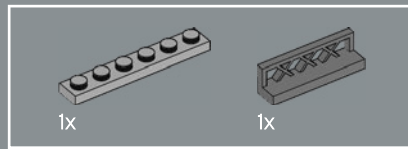
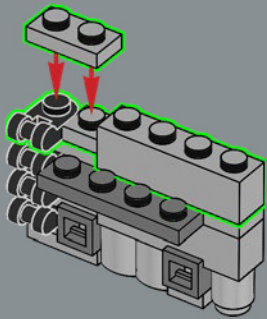

20

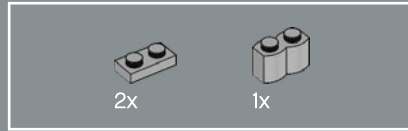
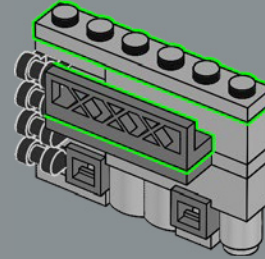

21

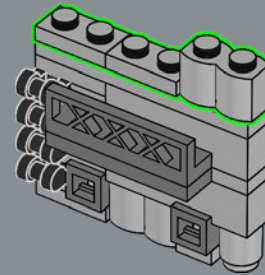

22

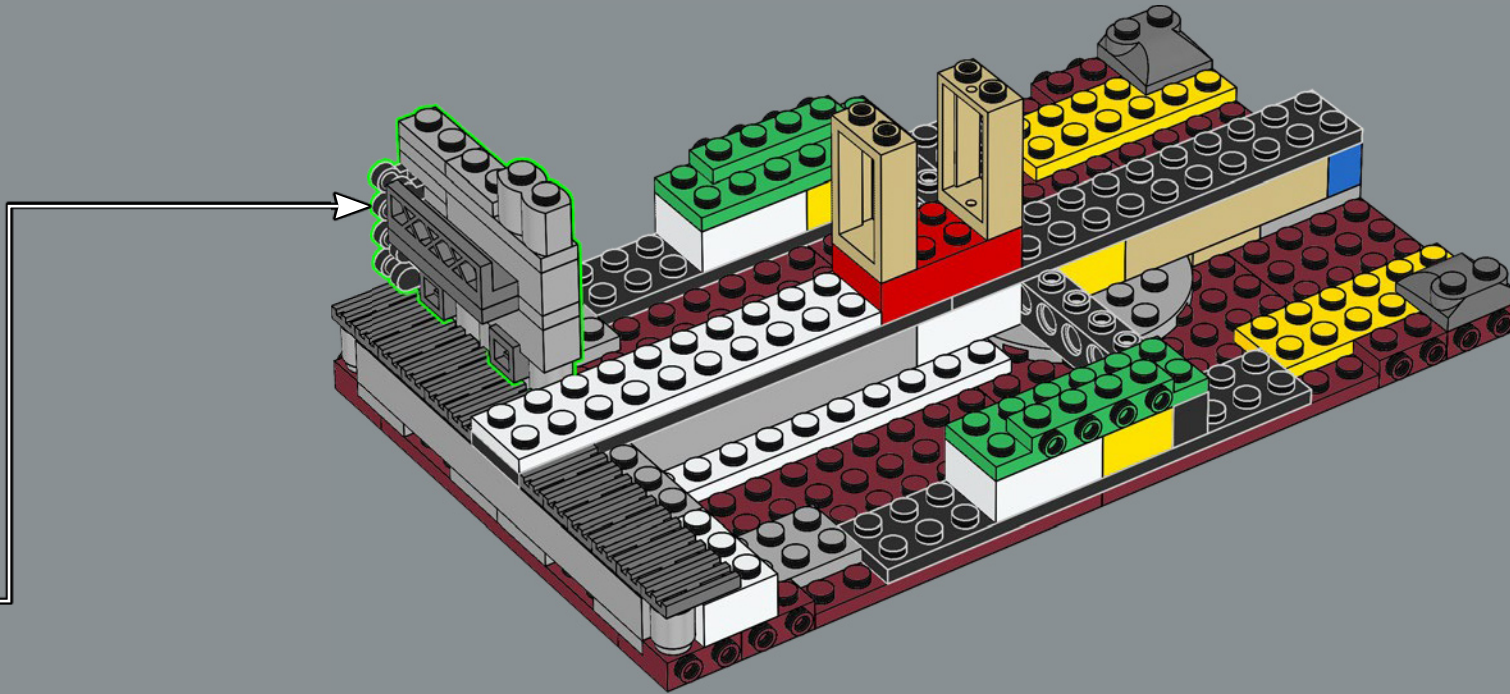

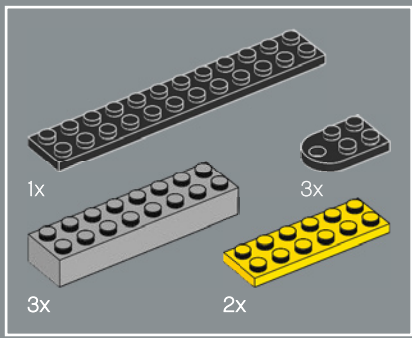

23

1

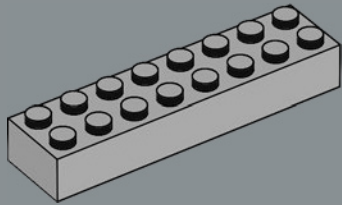

2

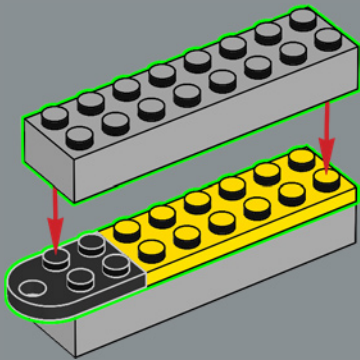

3

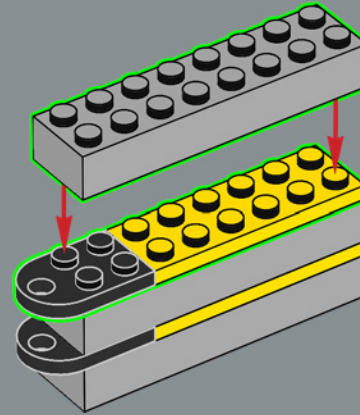

4

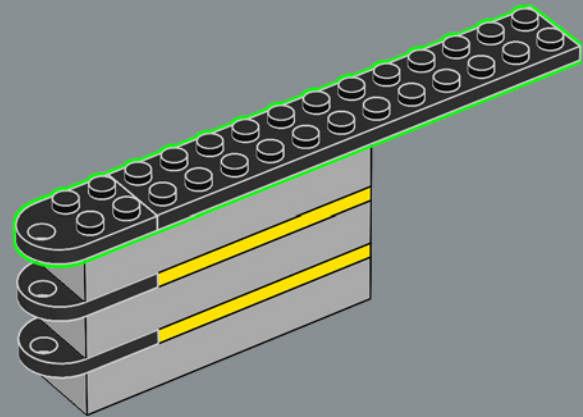

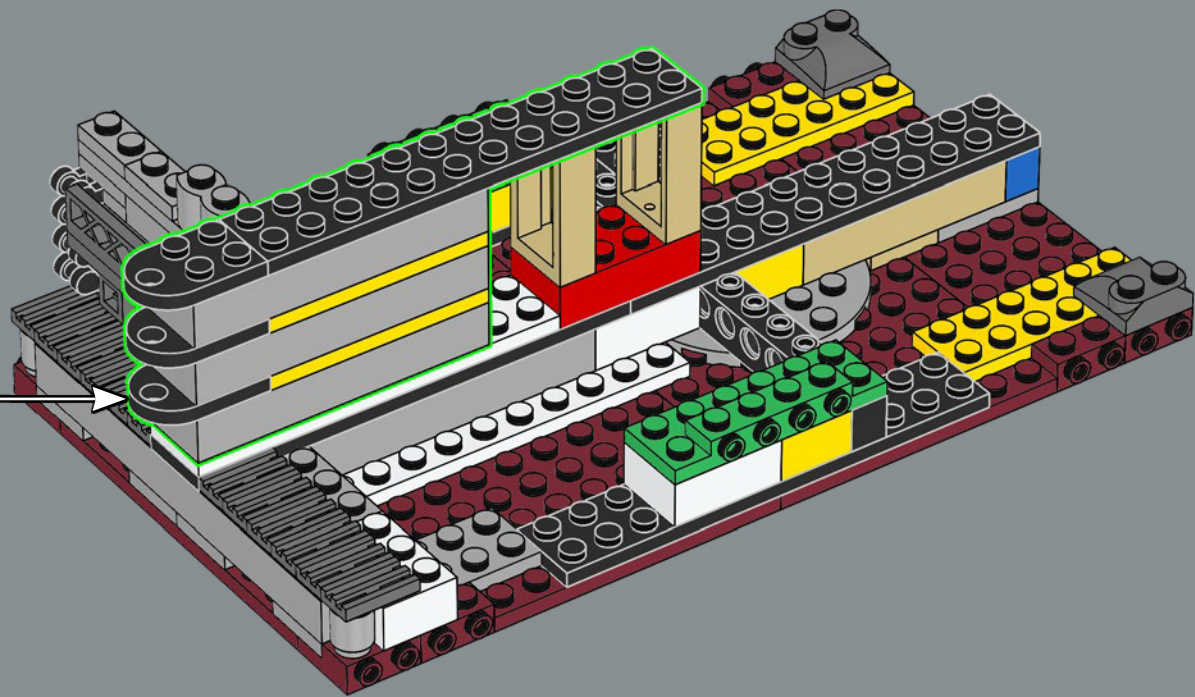

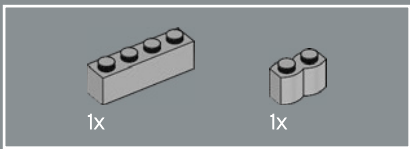

24

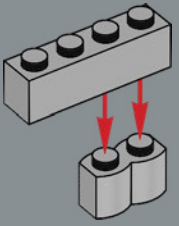

25

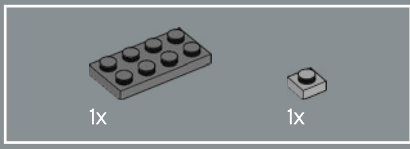
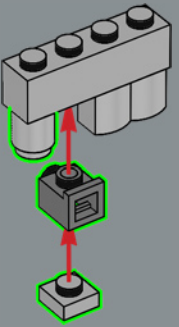

26

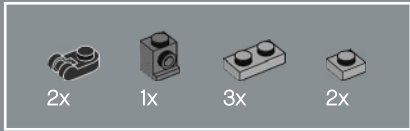
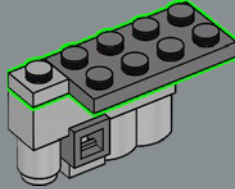

27

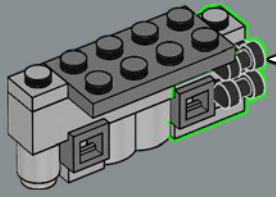
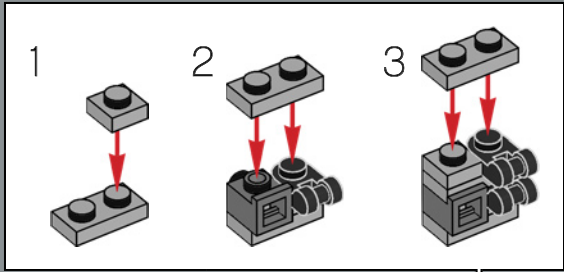

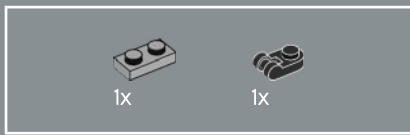

28

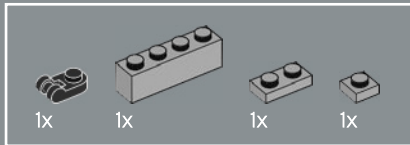
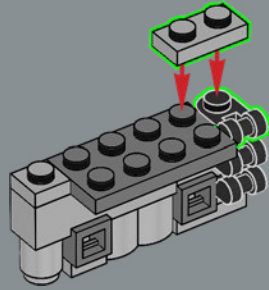

29

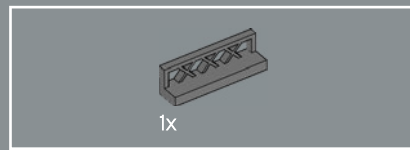
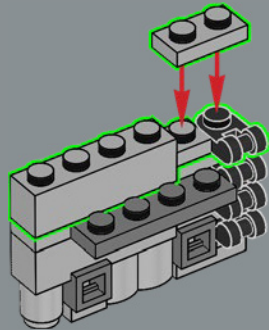

30

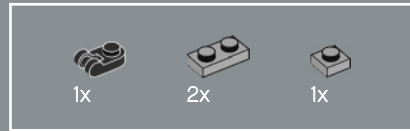
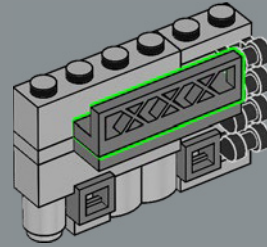

31

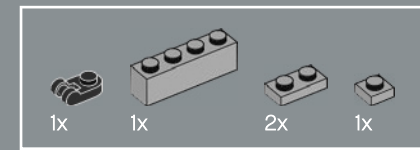
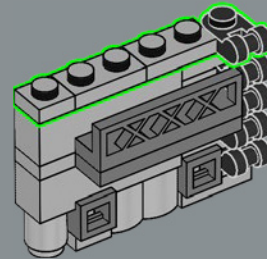

32

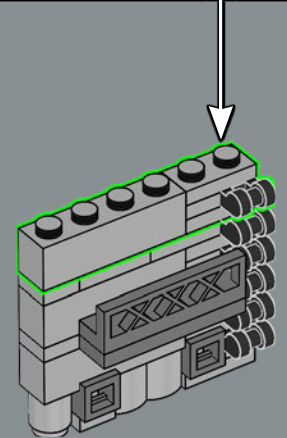
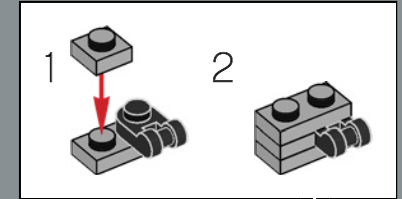

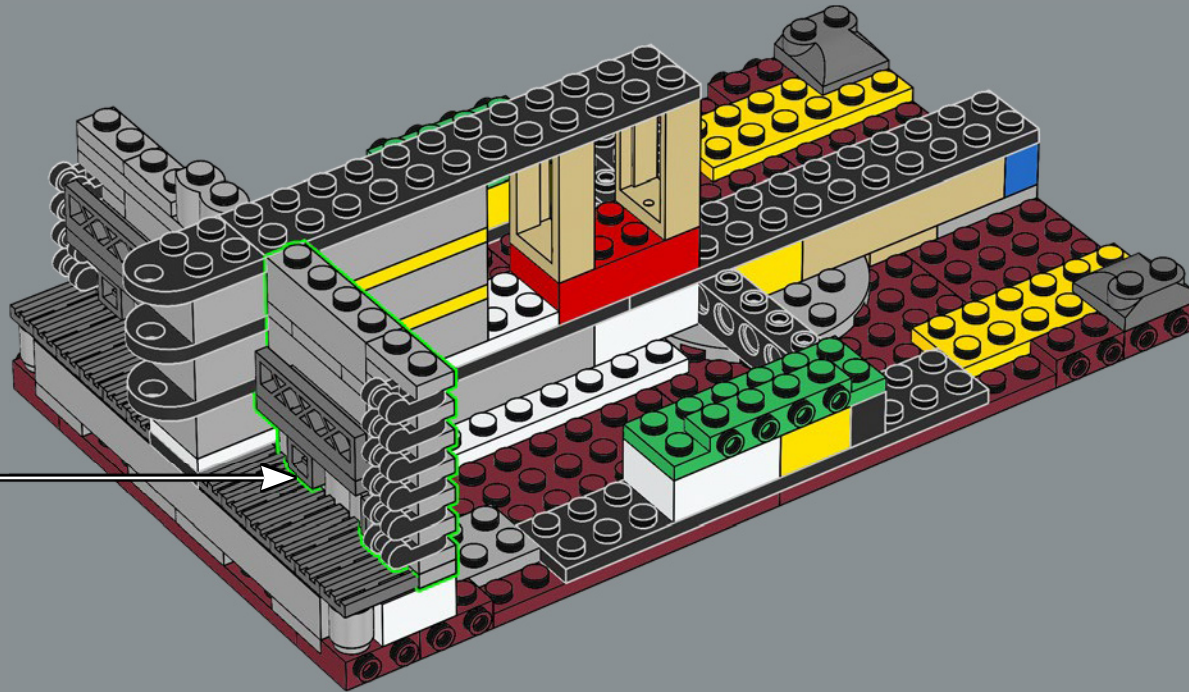

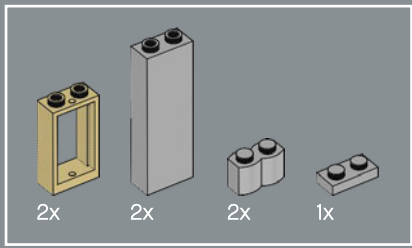

34

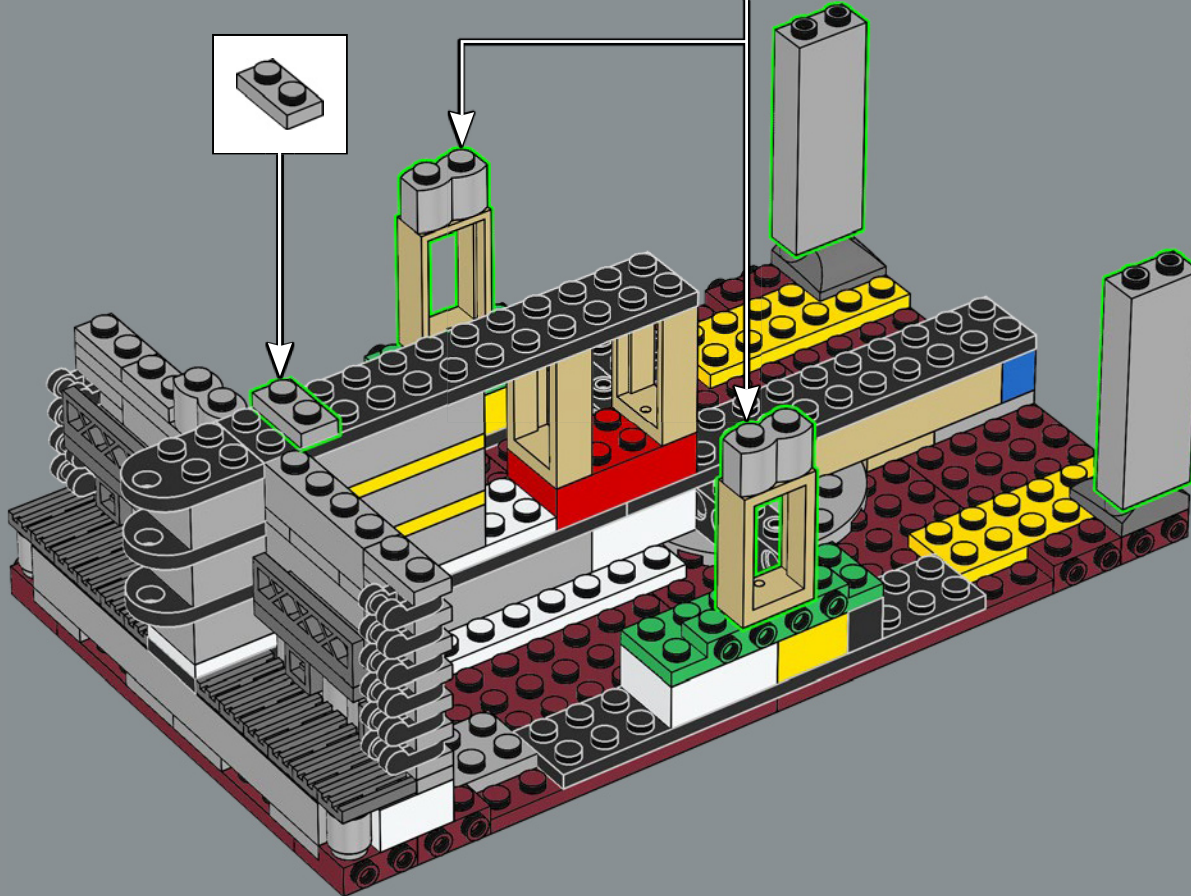
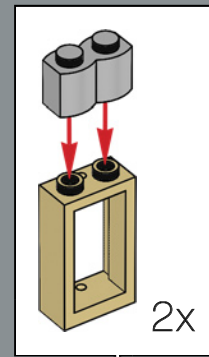

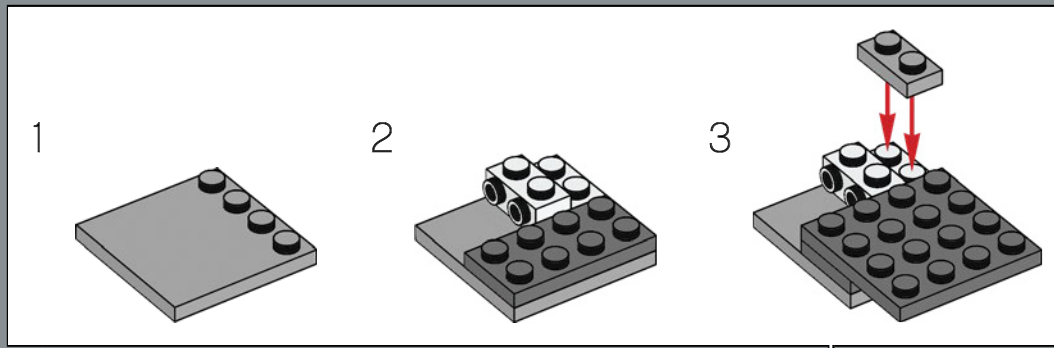
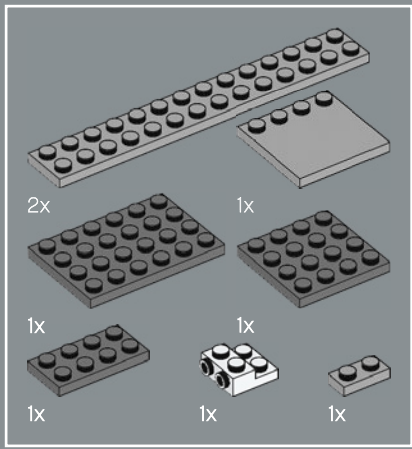

35

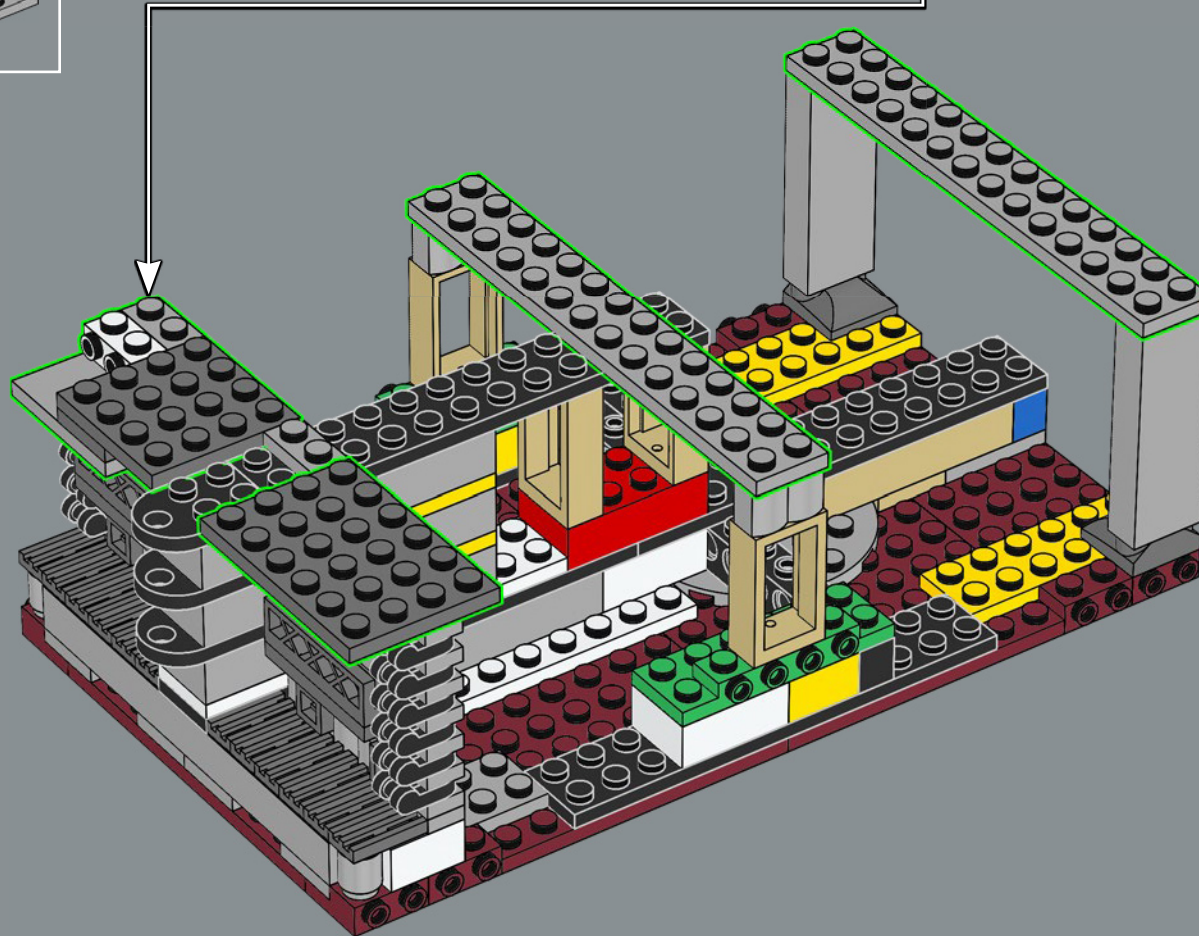

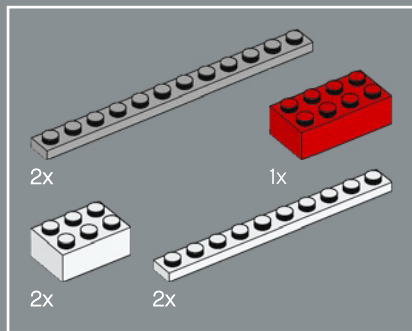

36

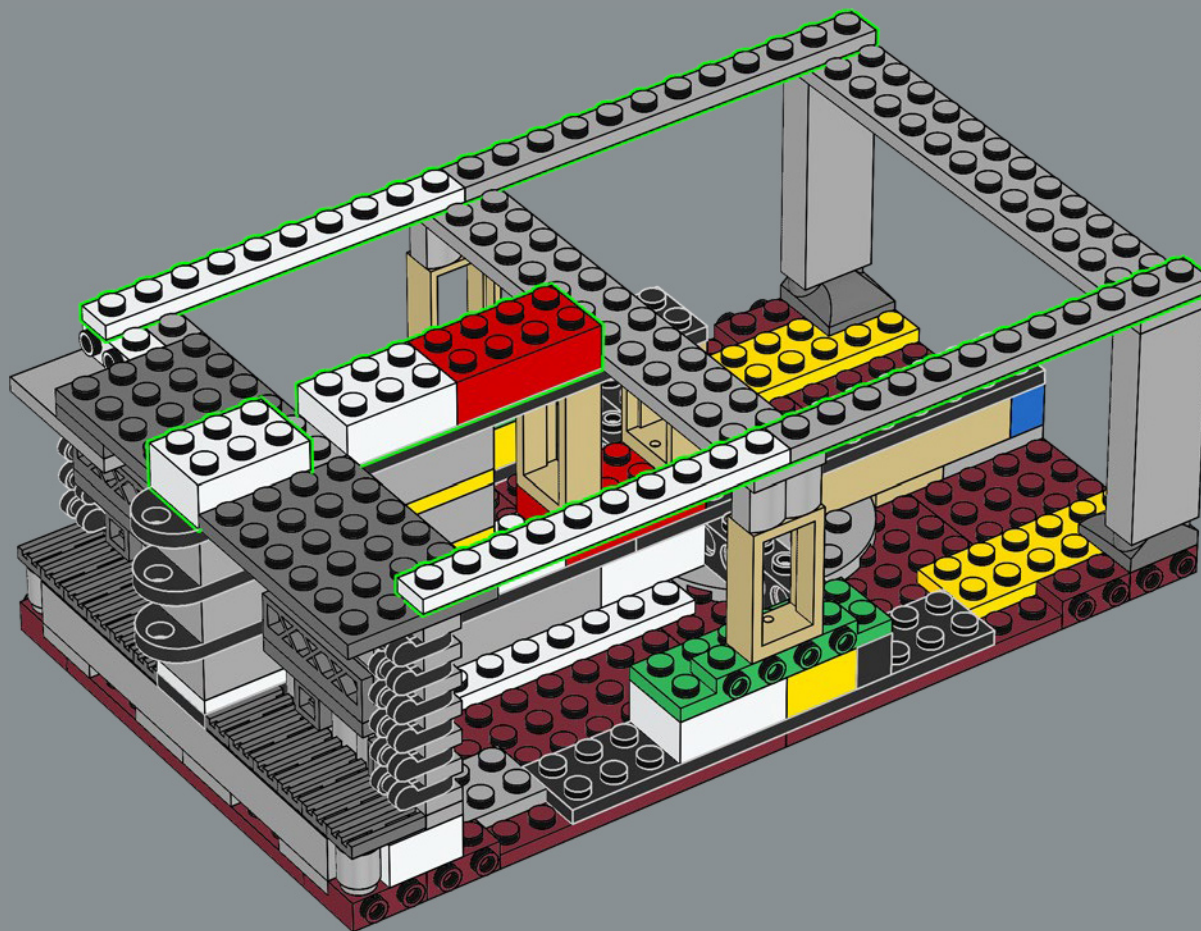

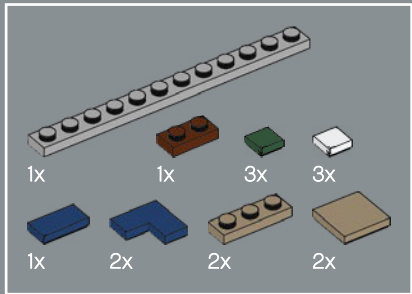
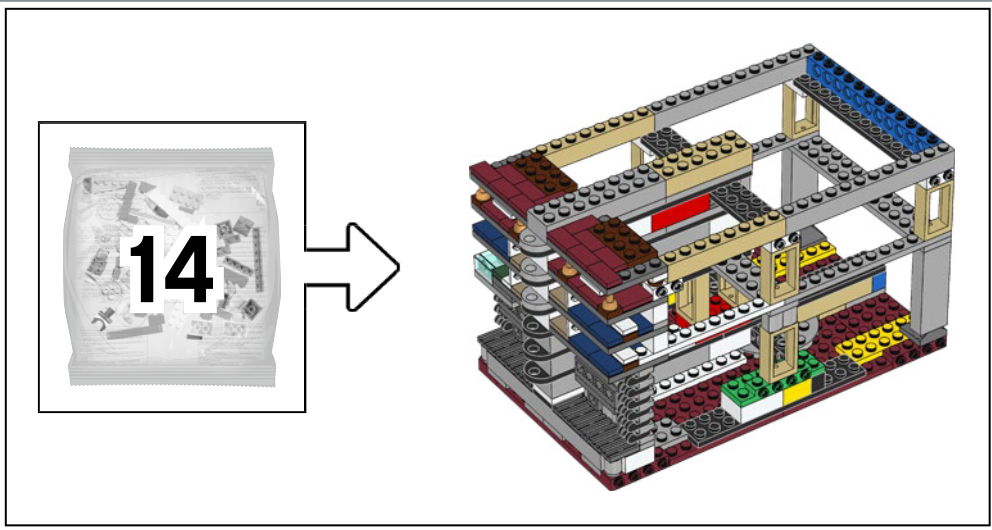

37

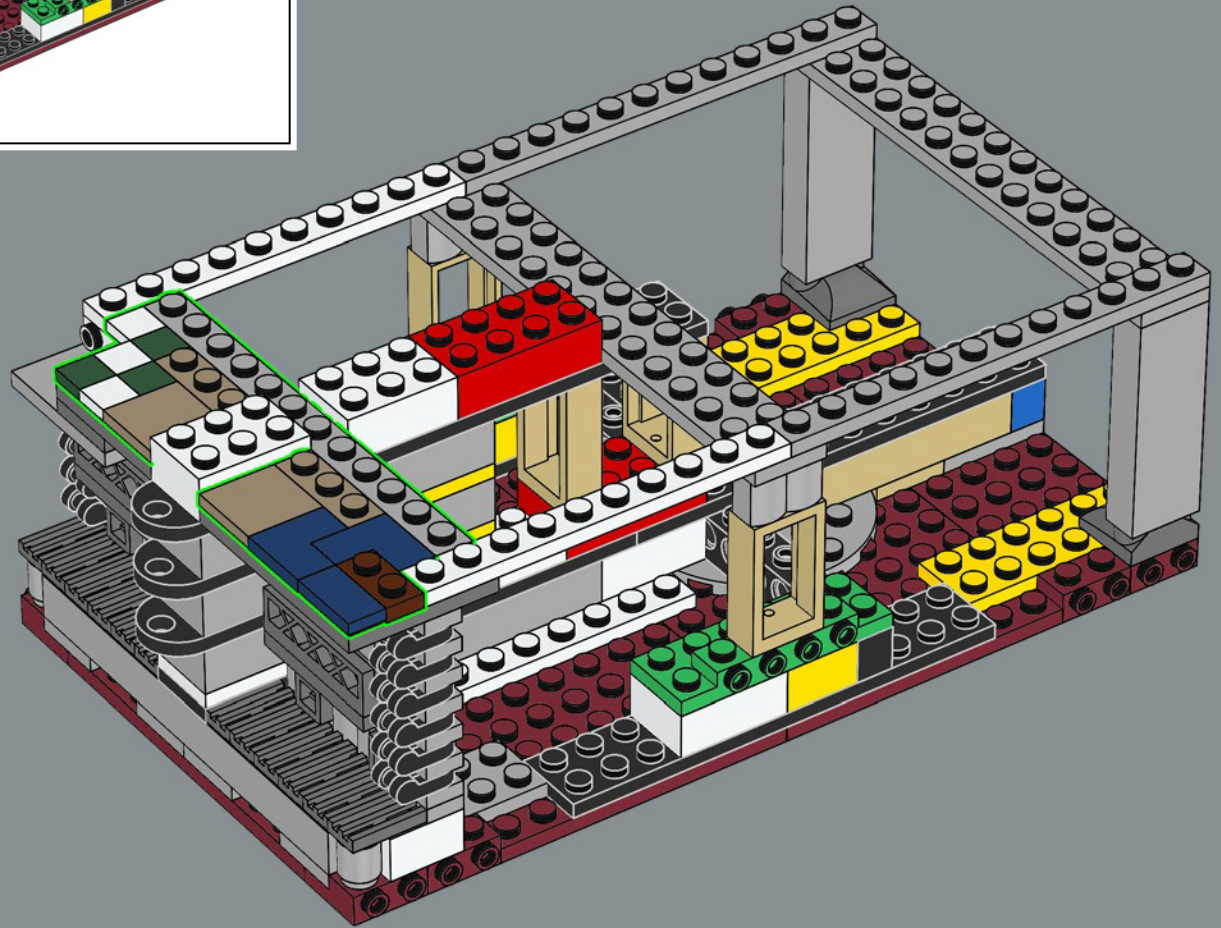

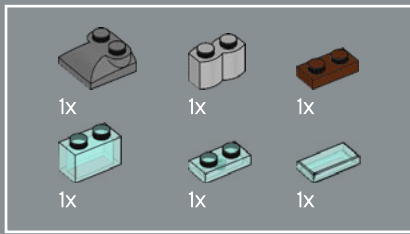

38

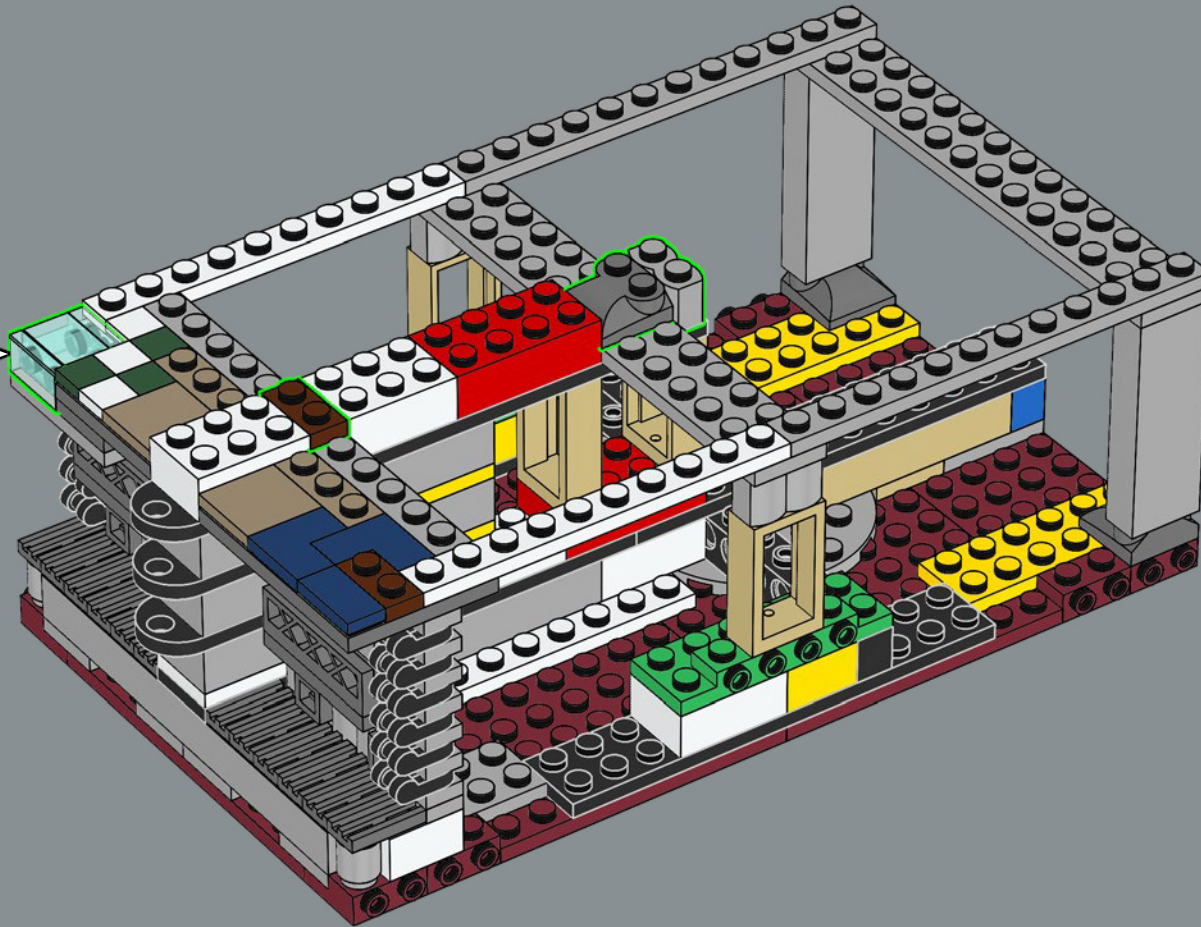
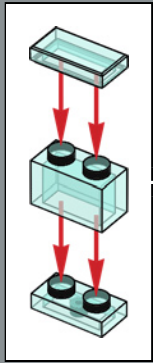

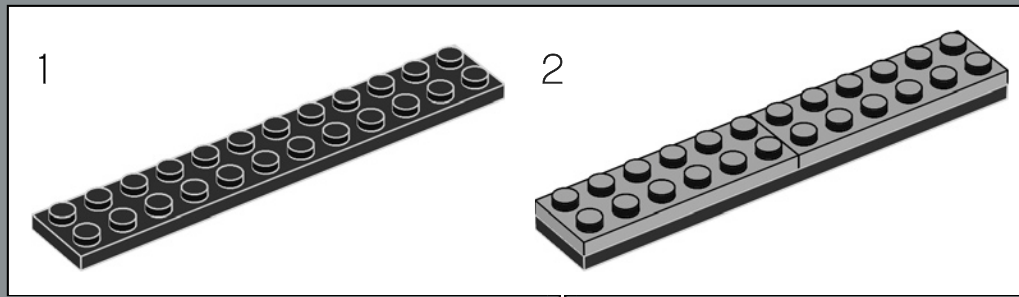
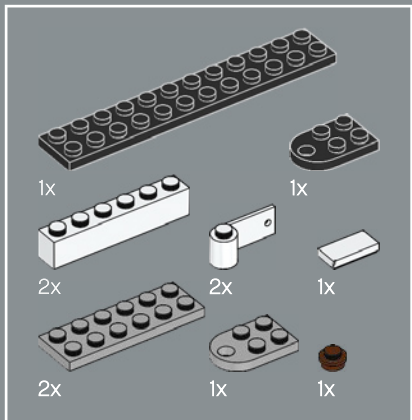

39

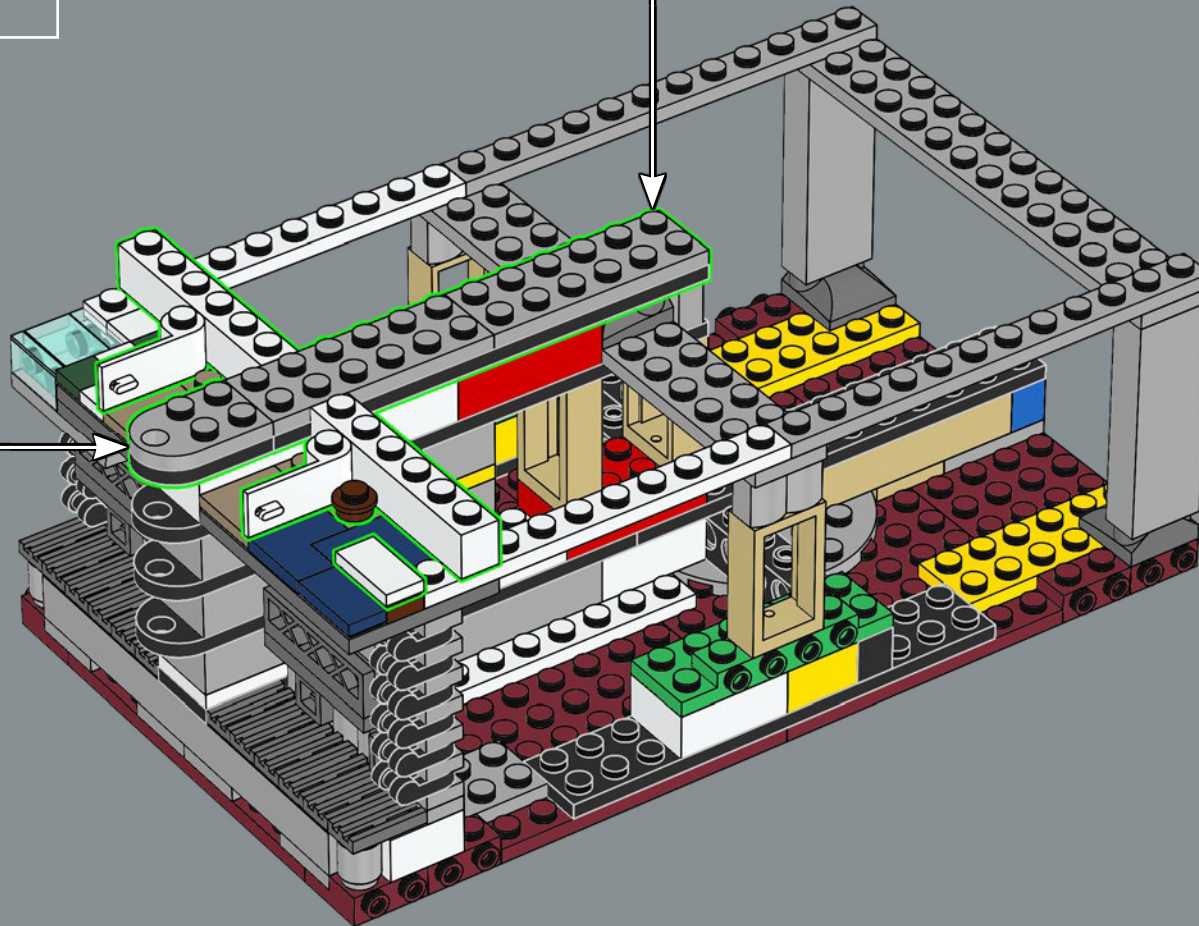
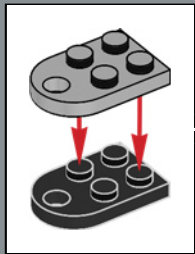

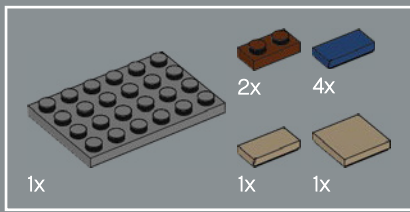

40

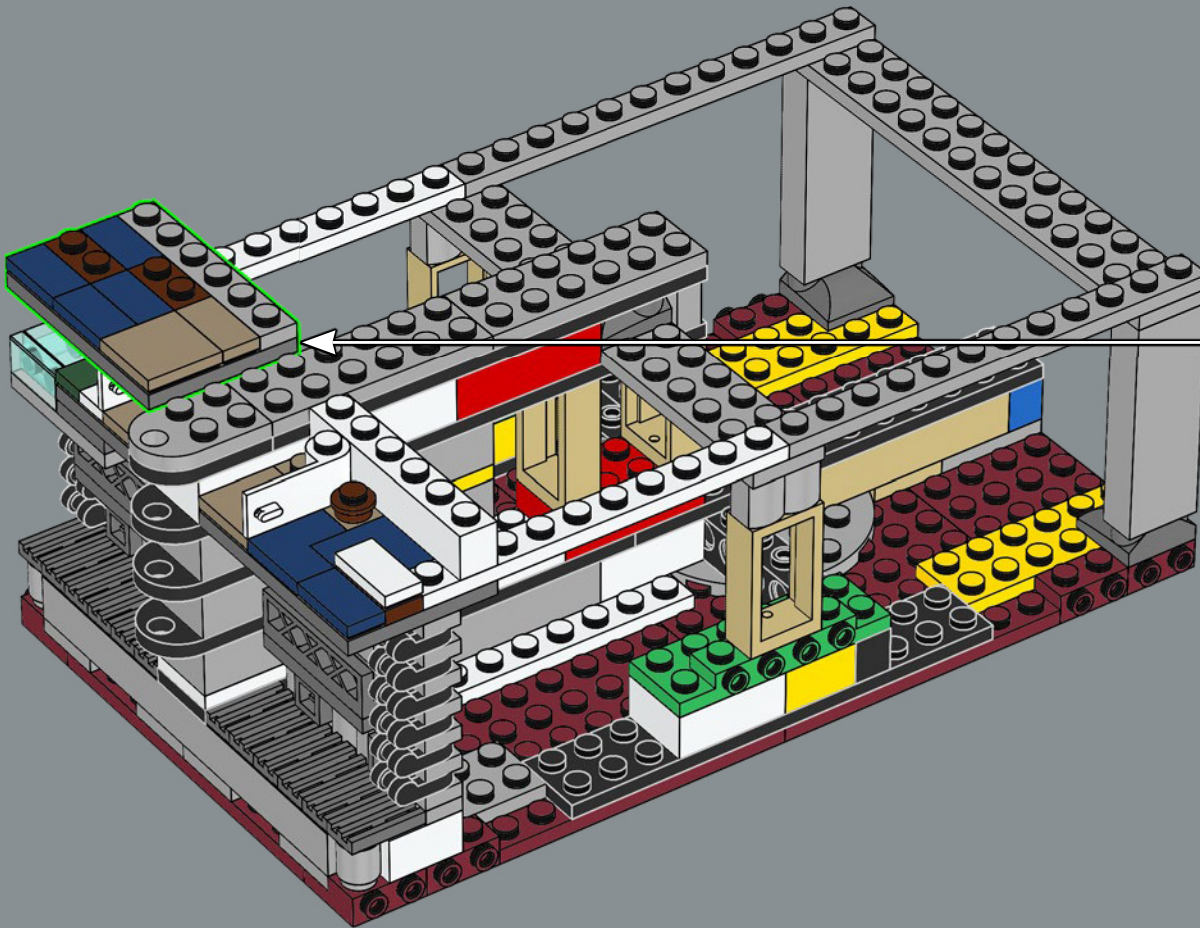
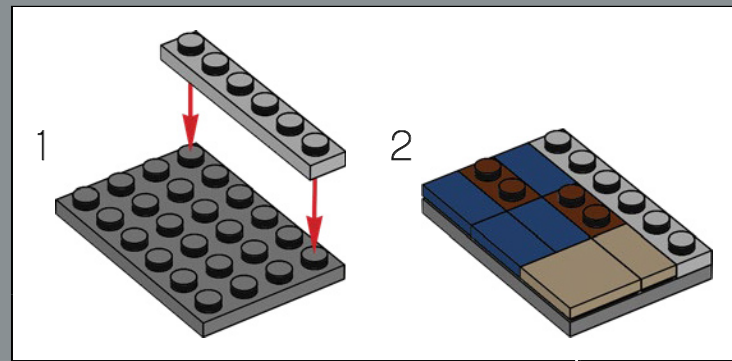

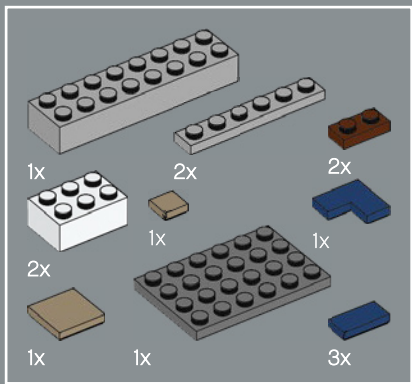

41

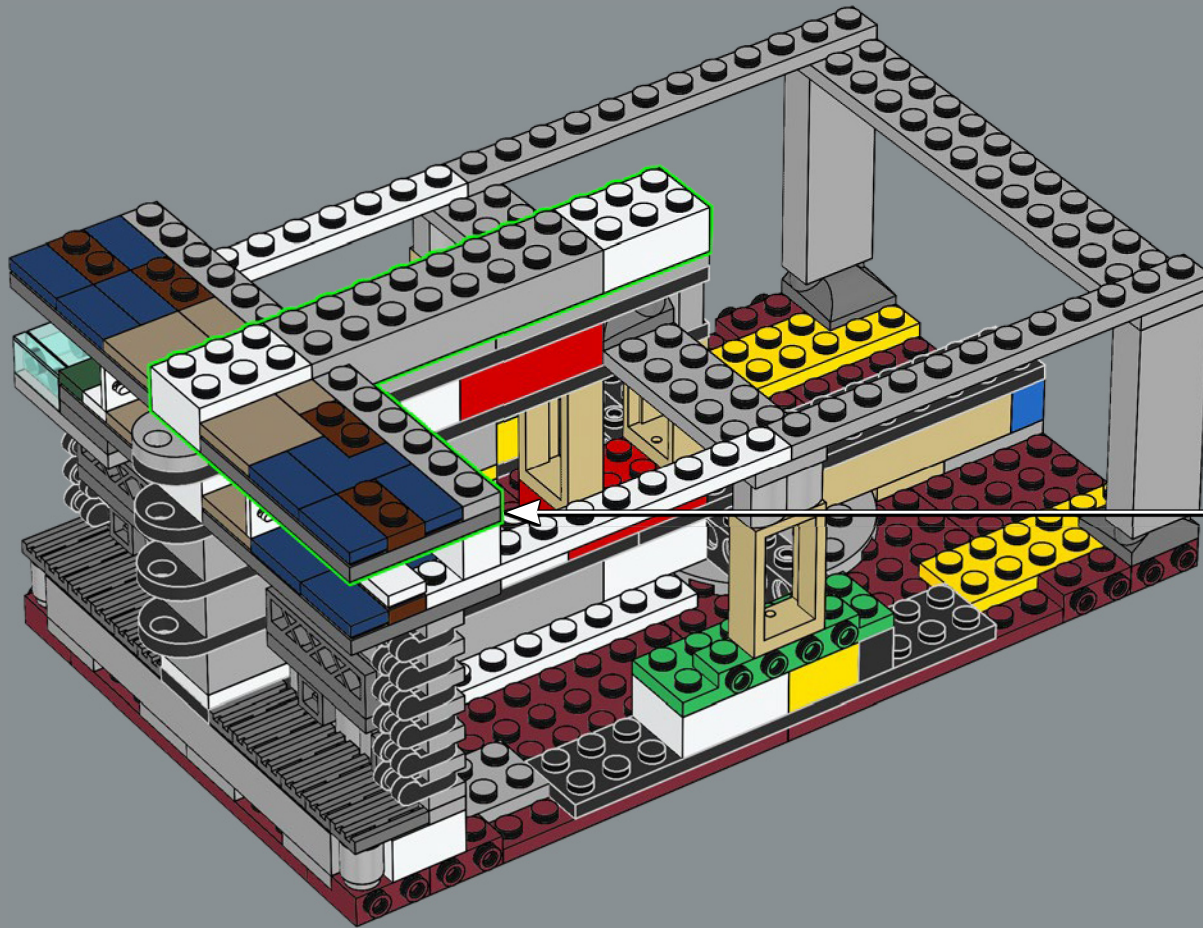
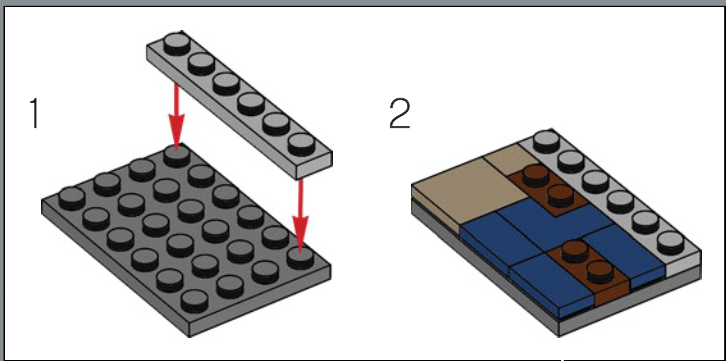

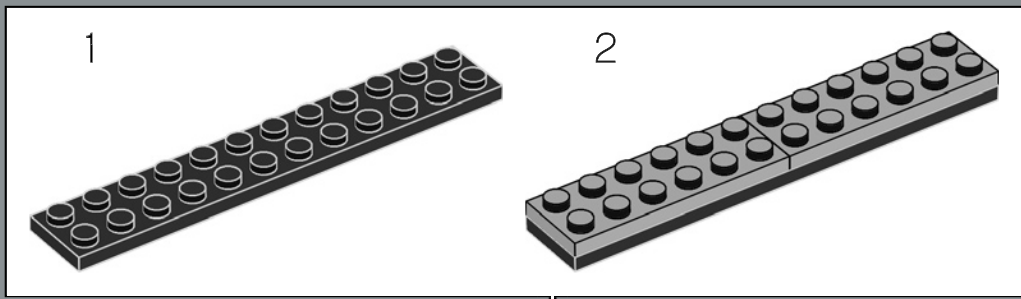
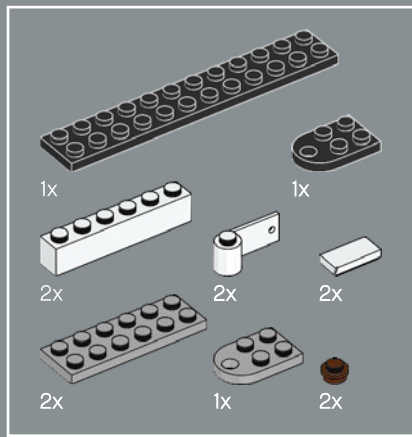

42

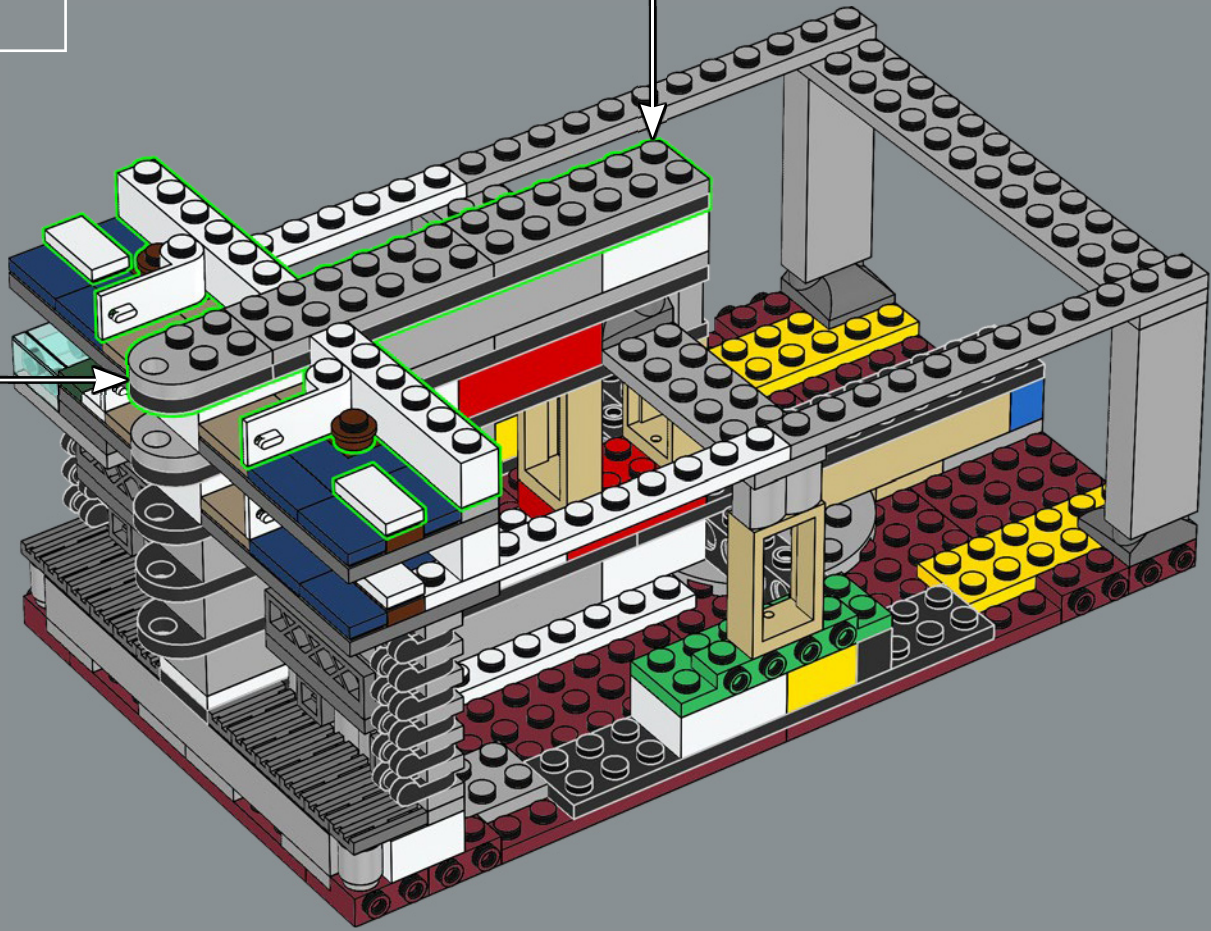
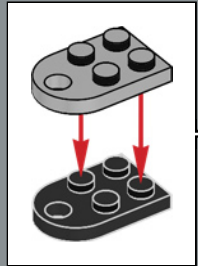

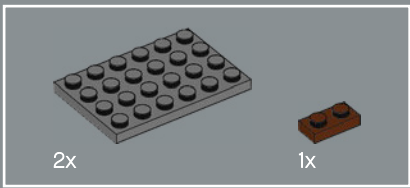

43

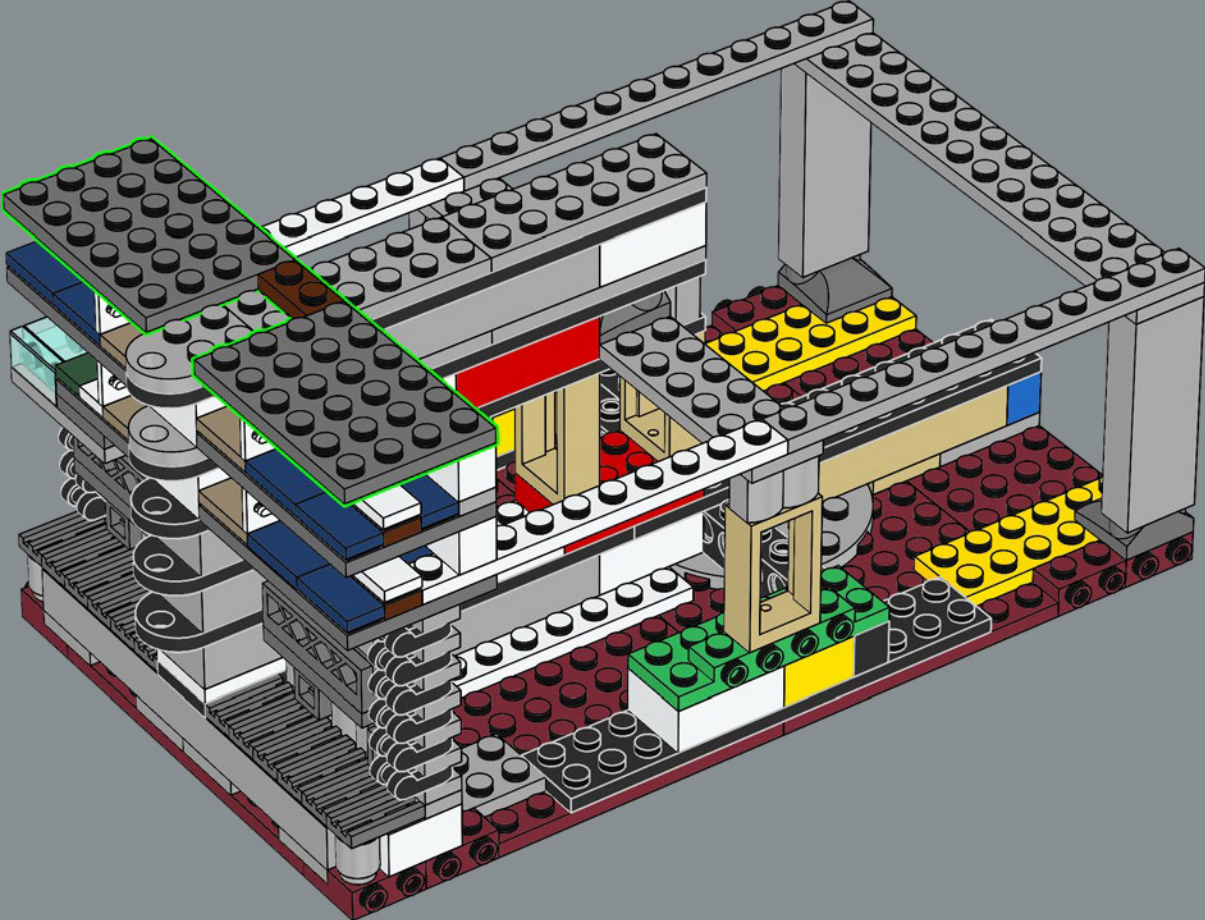

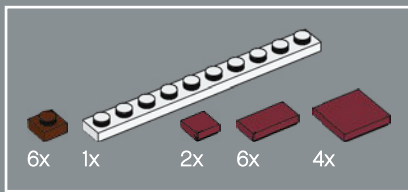

44

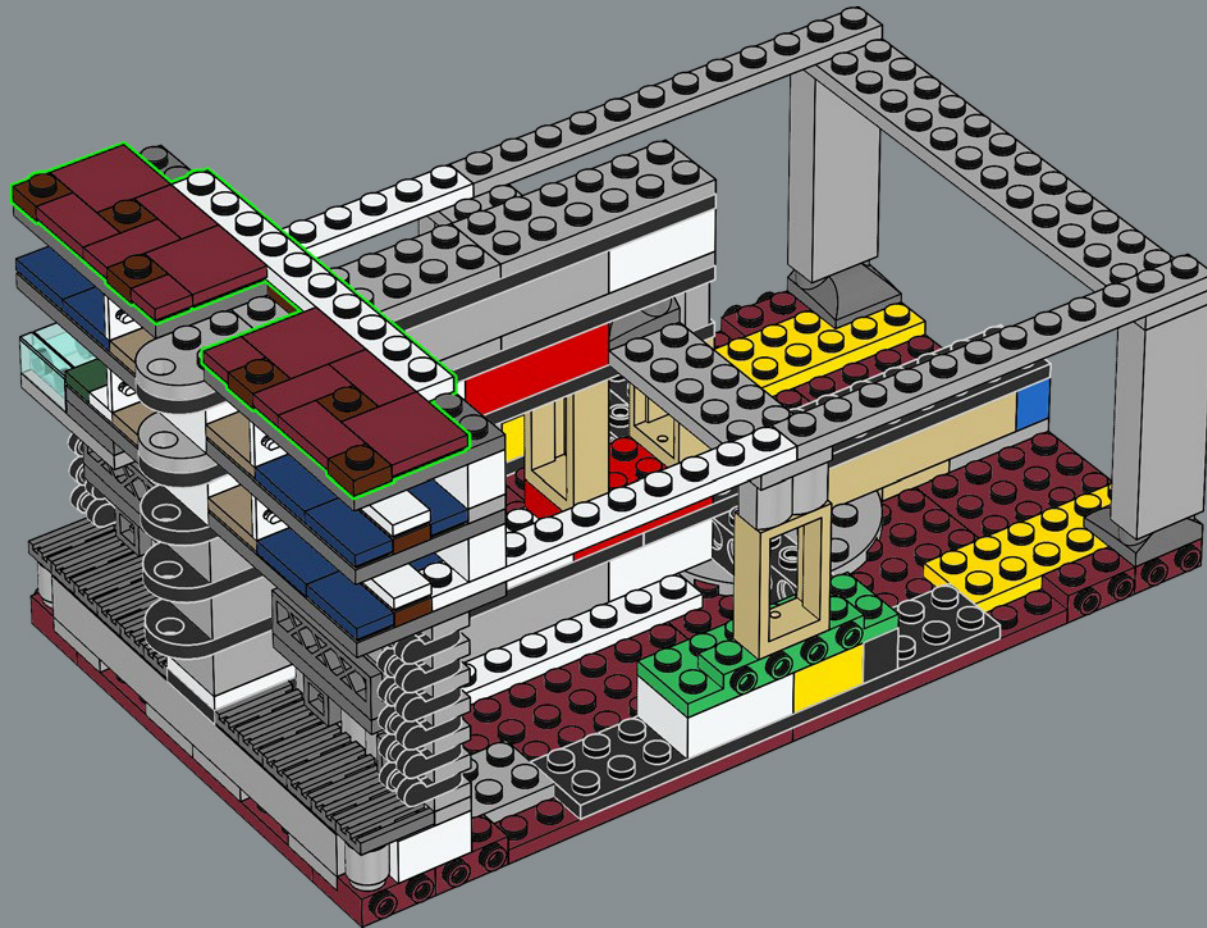

Le paquebot dispose de son propre système hydraulique, capable de chauffer et de pomper l'eau dans toutes les parties du navire.

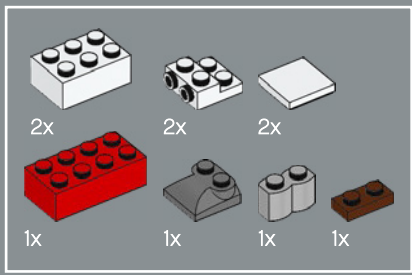

45

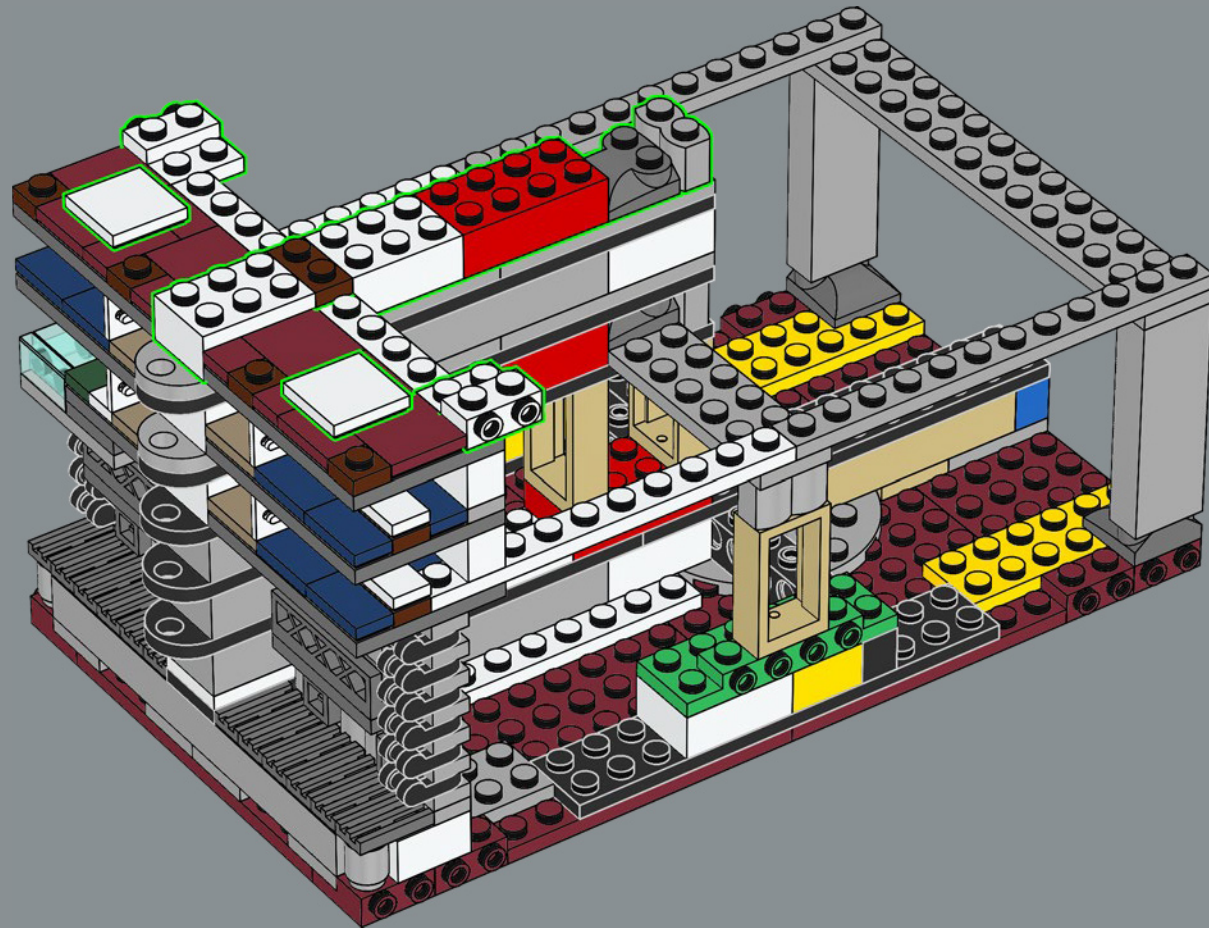

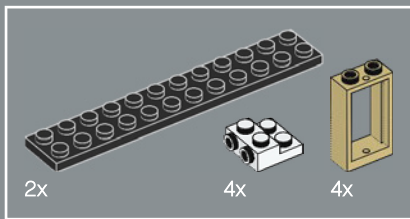

46

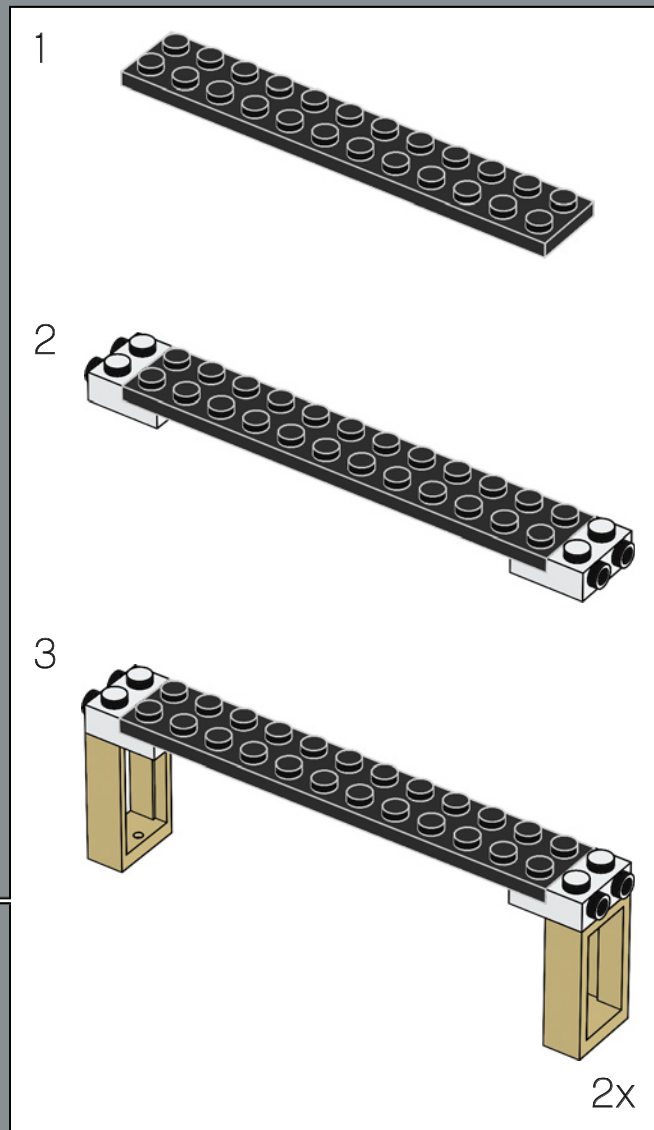
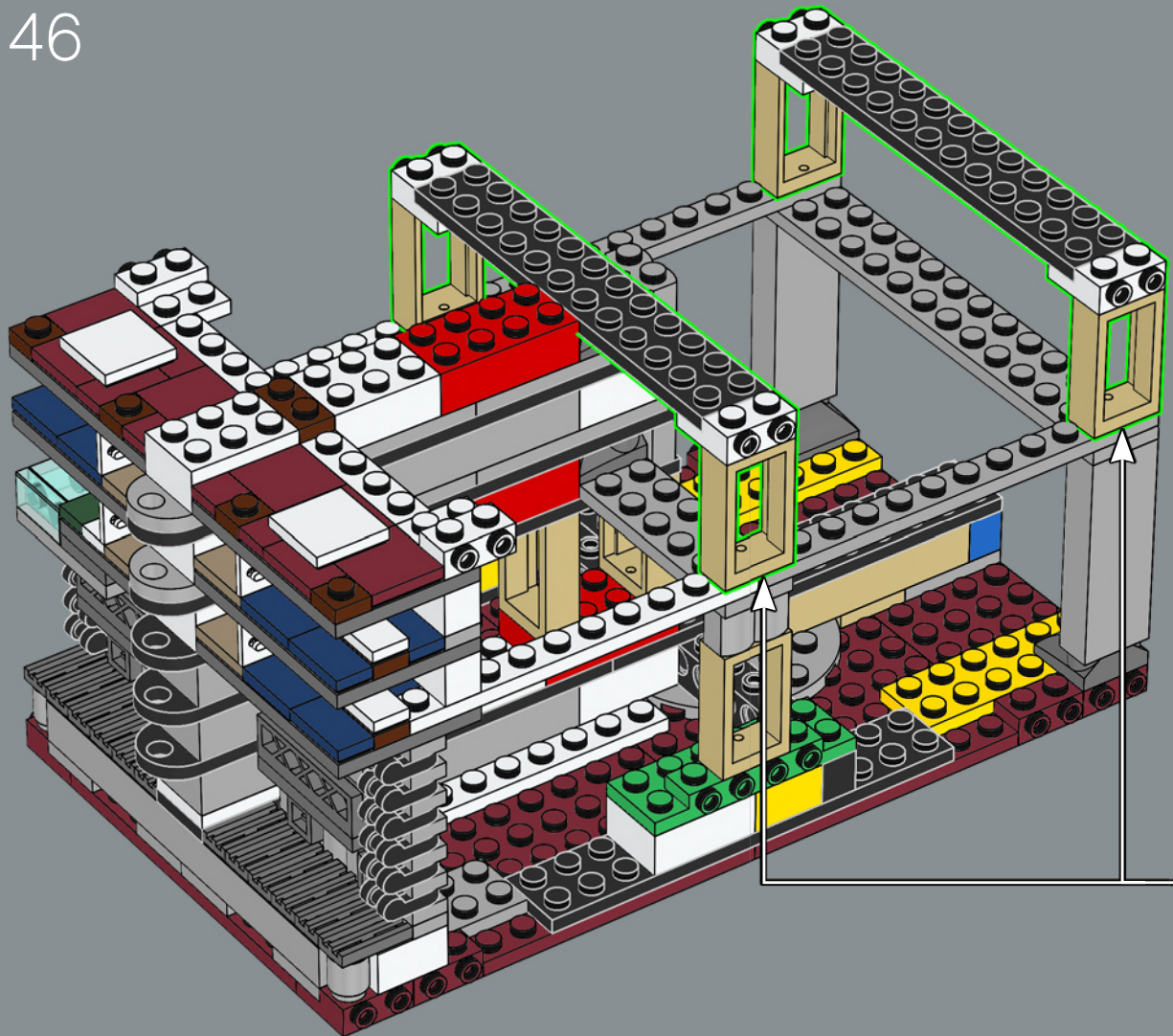

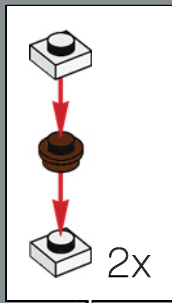
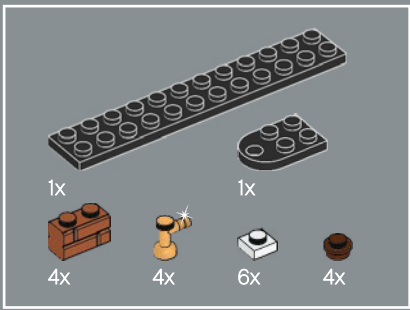

47

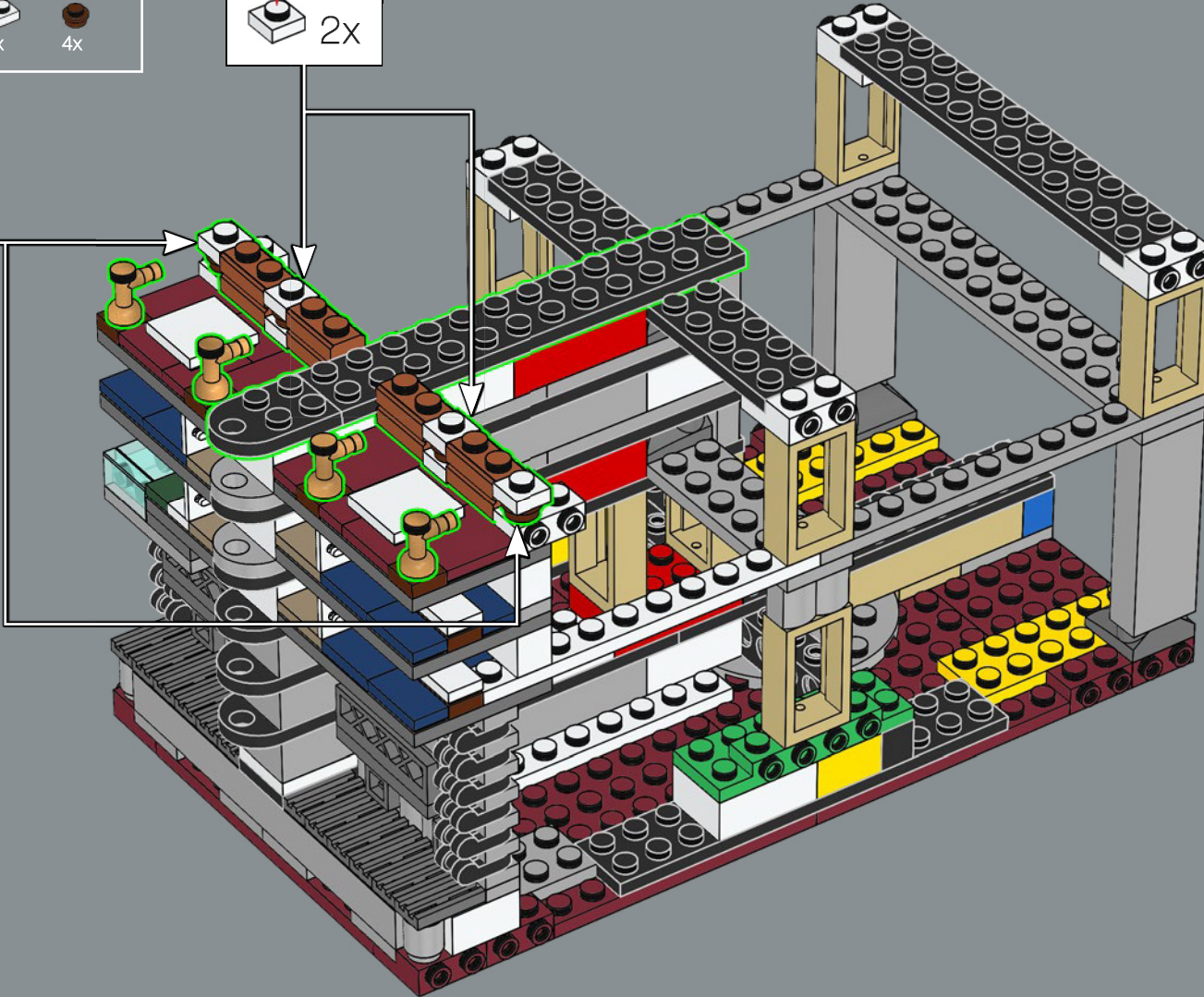
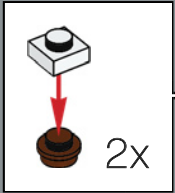

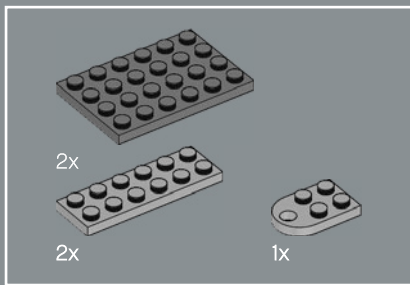

48

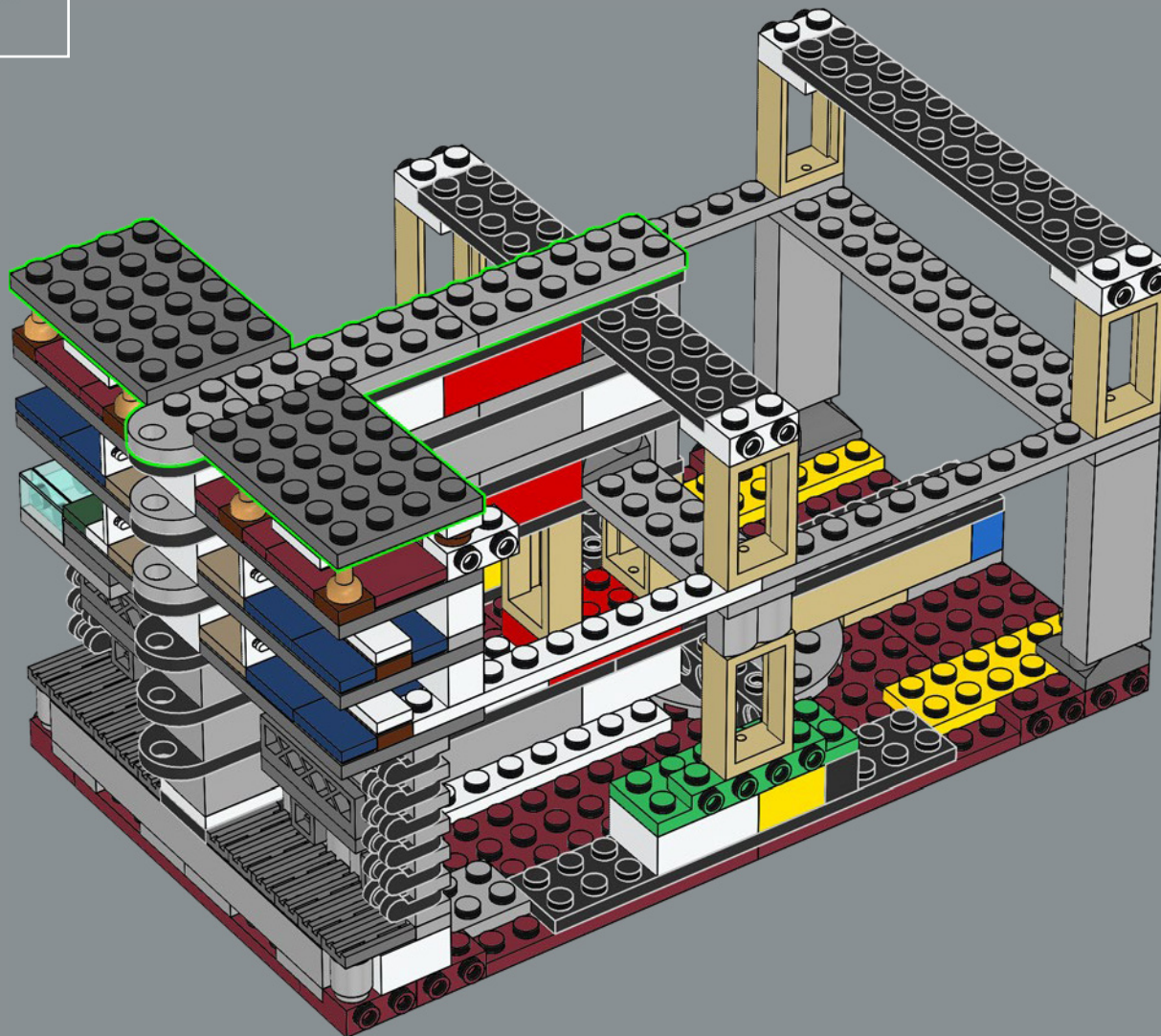



49

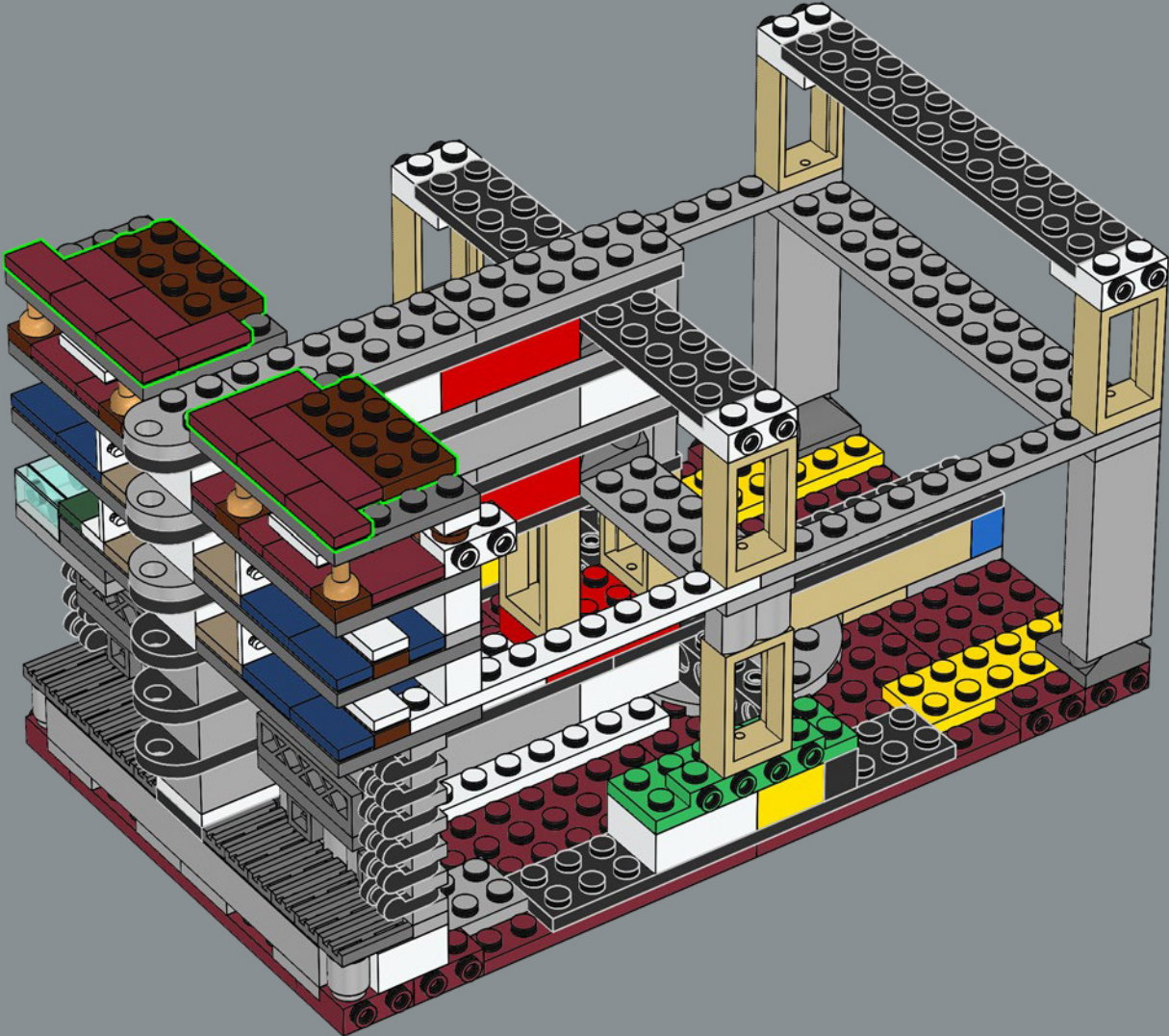

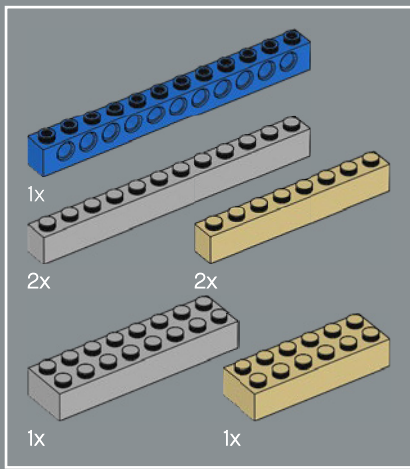

50

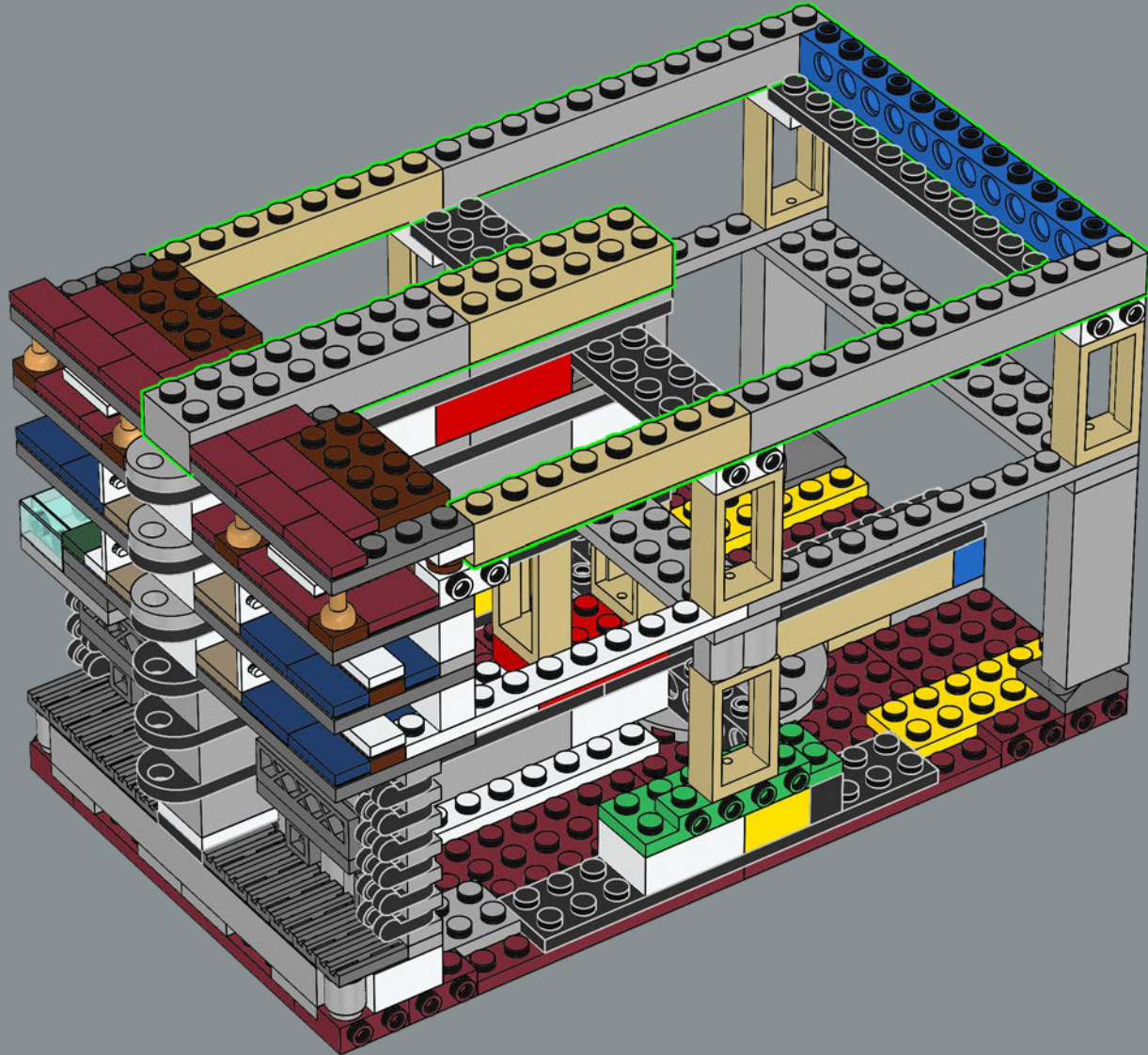

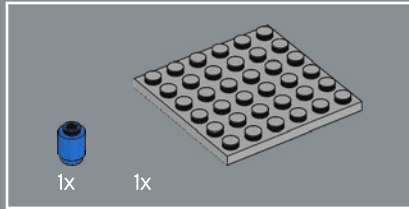
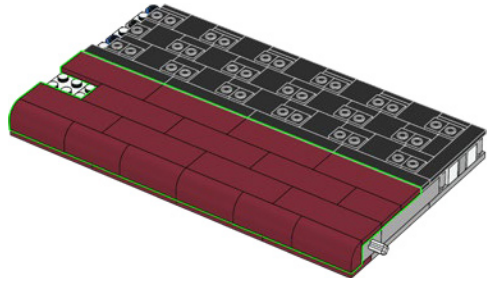
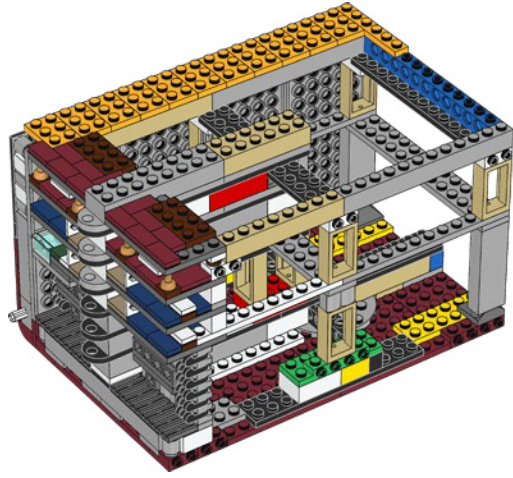
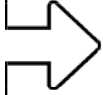

51

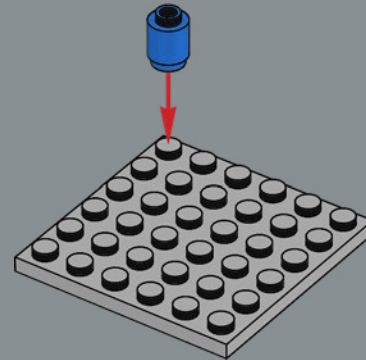

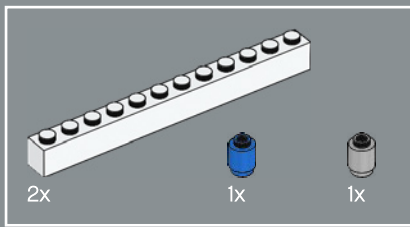

52

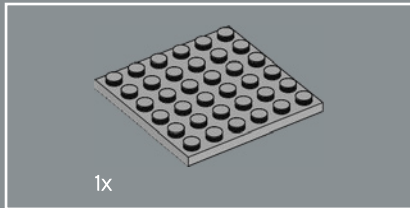
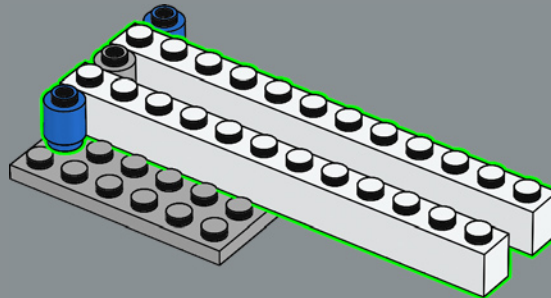

53

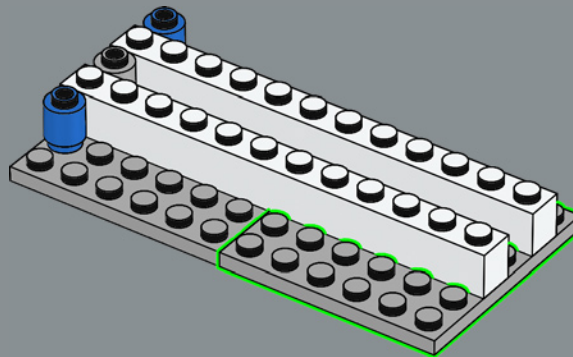

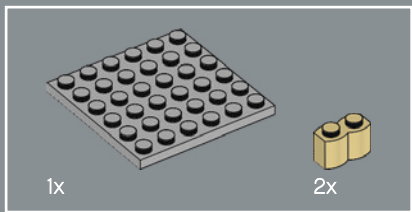

54

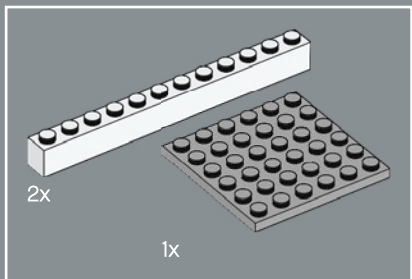
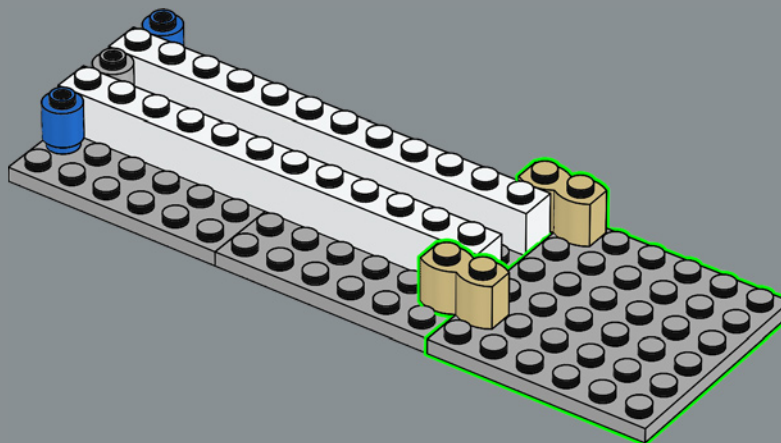

55

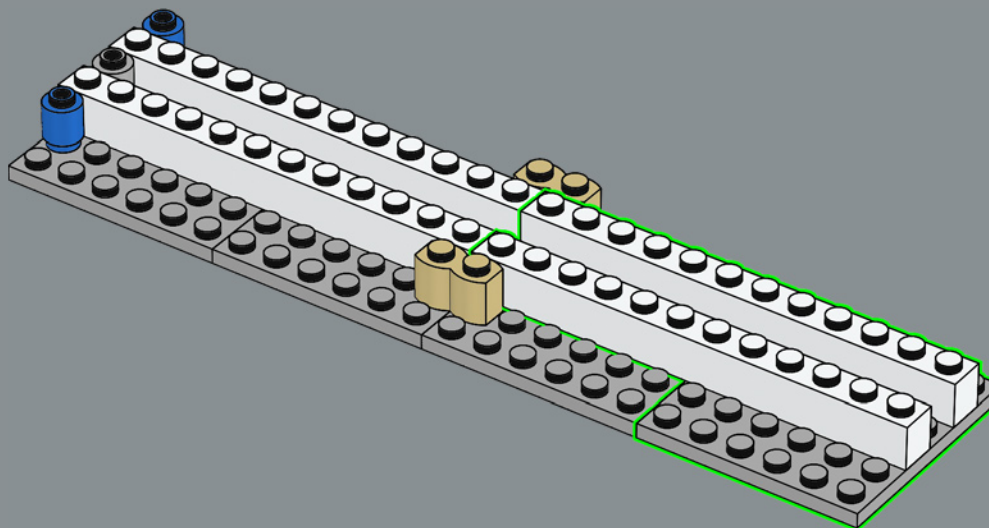

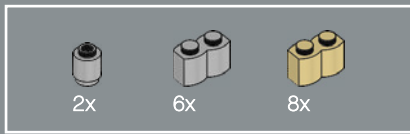

56

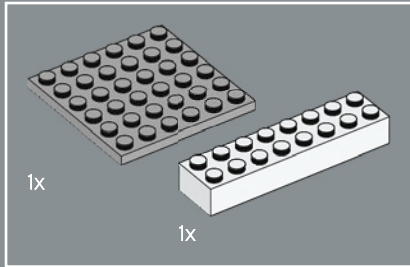
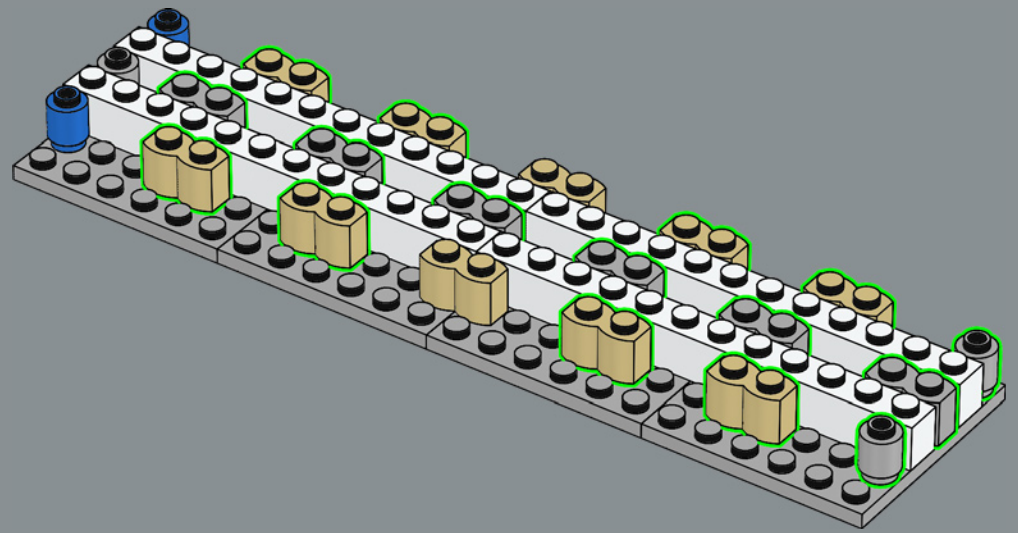

57

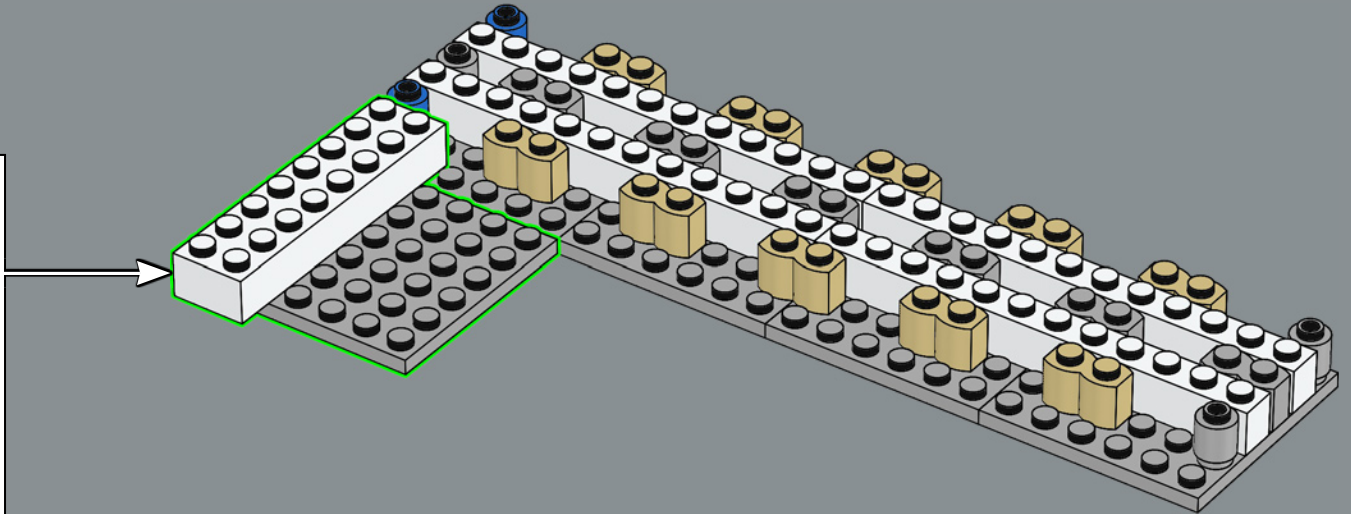
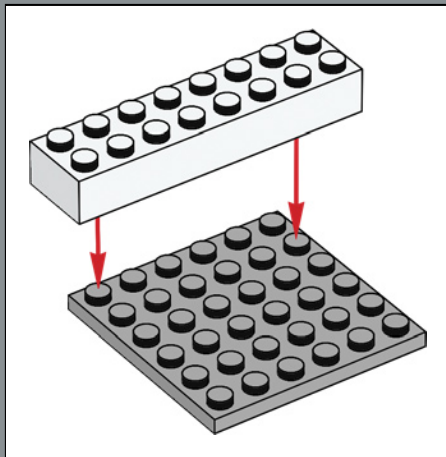

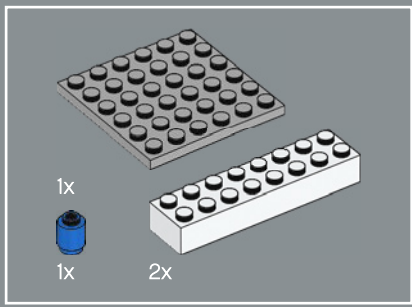

58

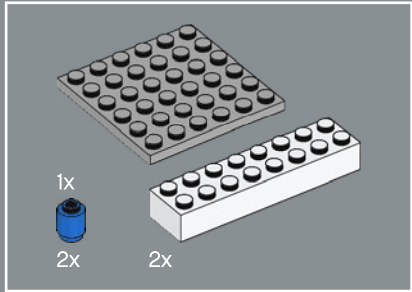
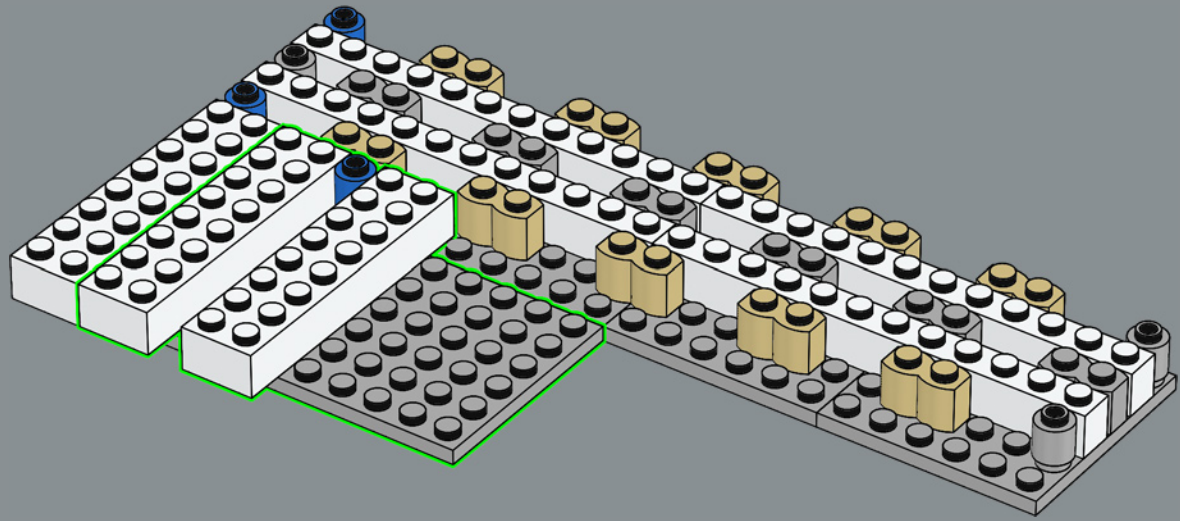

59

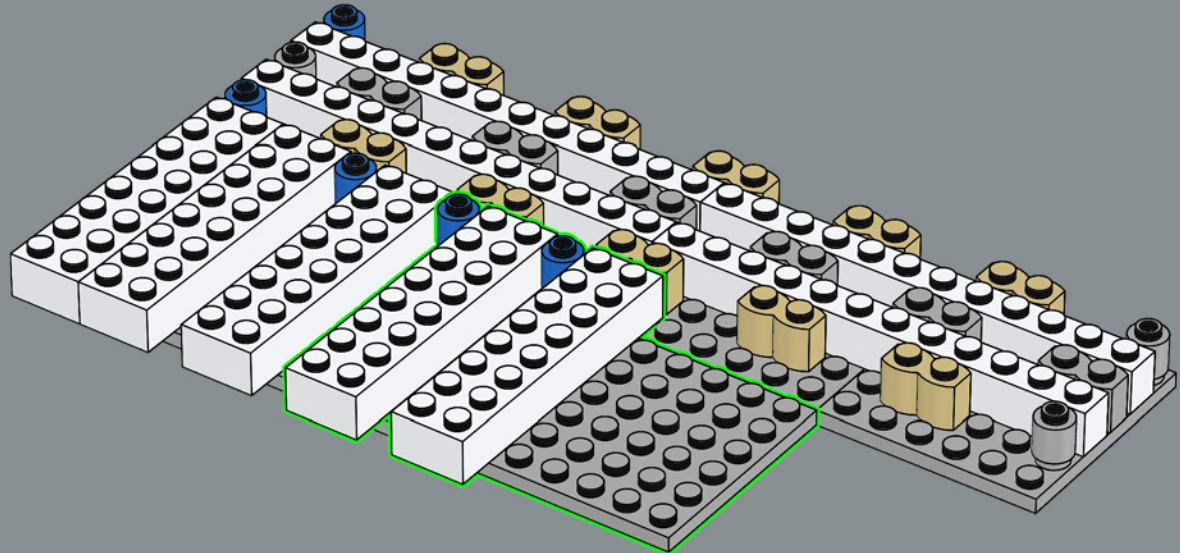

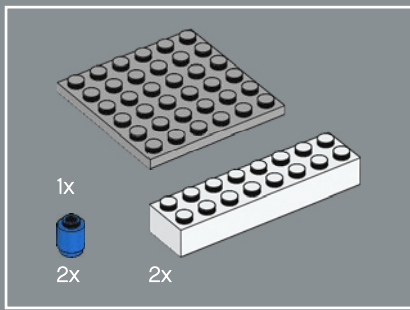

60

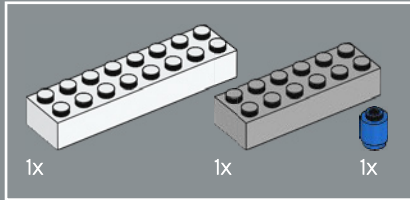
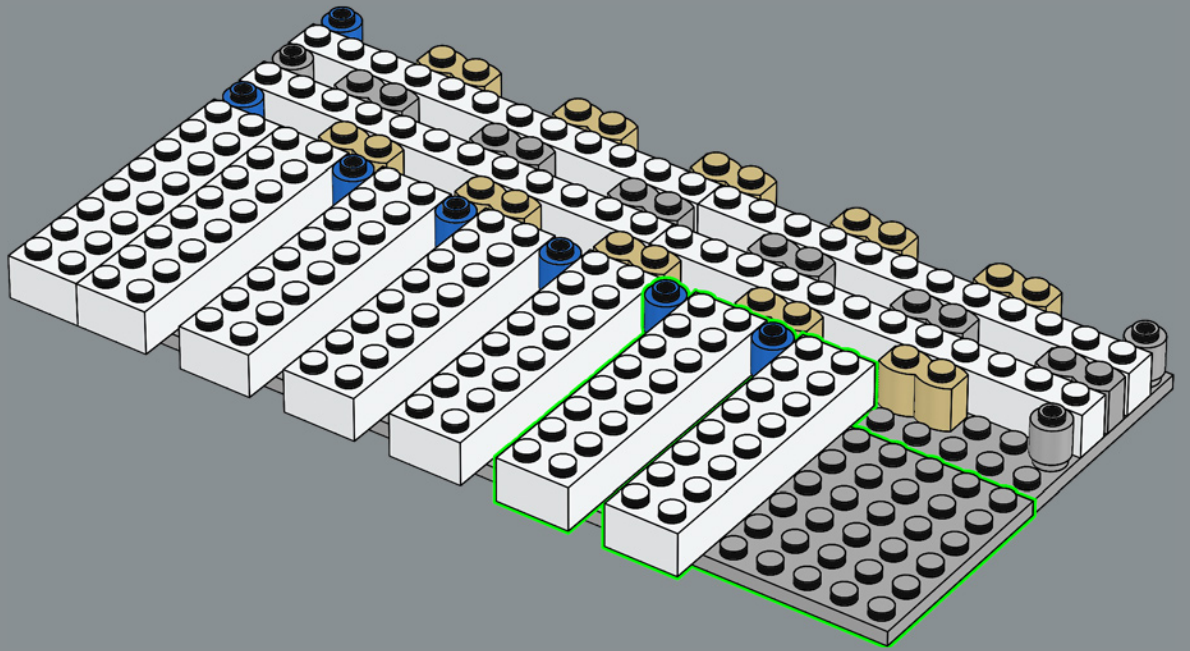

61

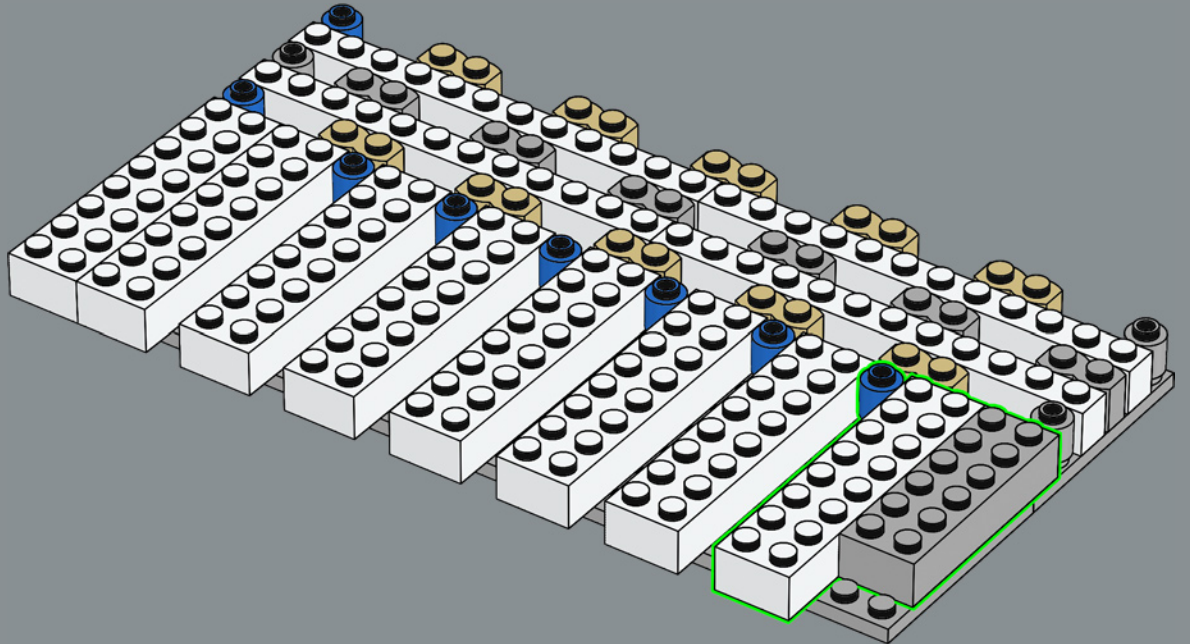

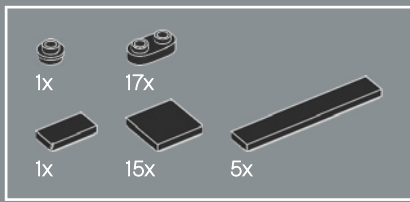

62

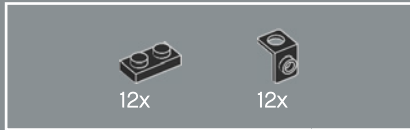
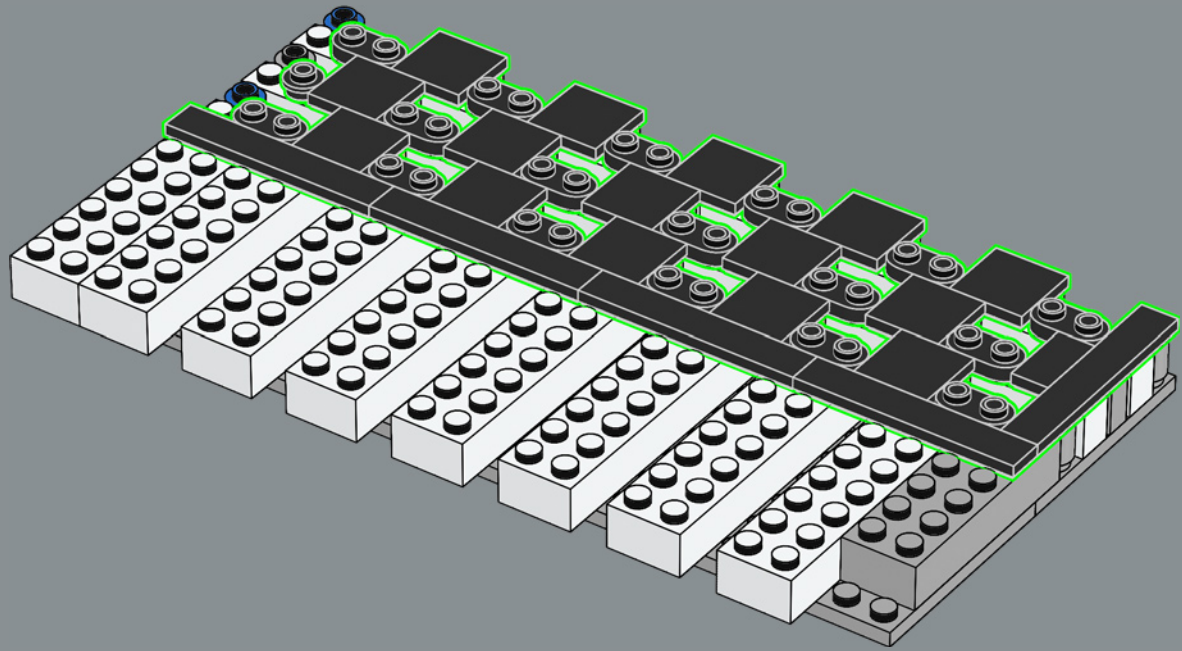

63

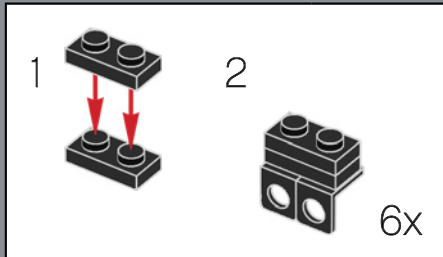
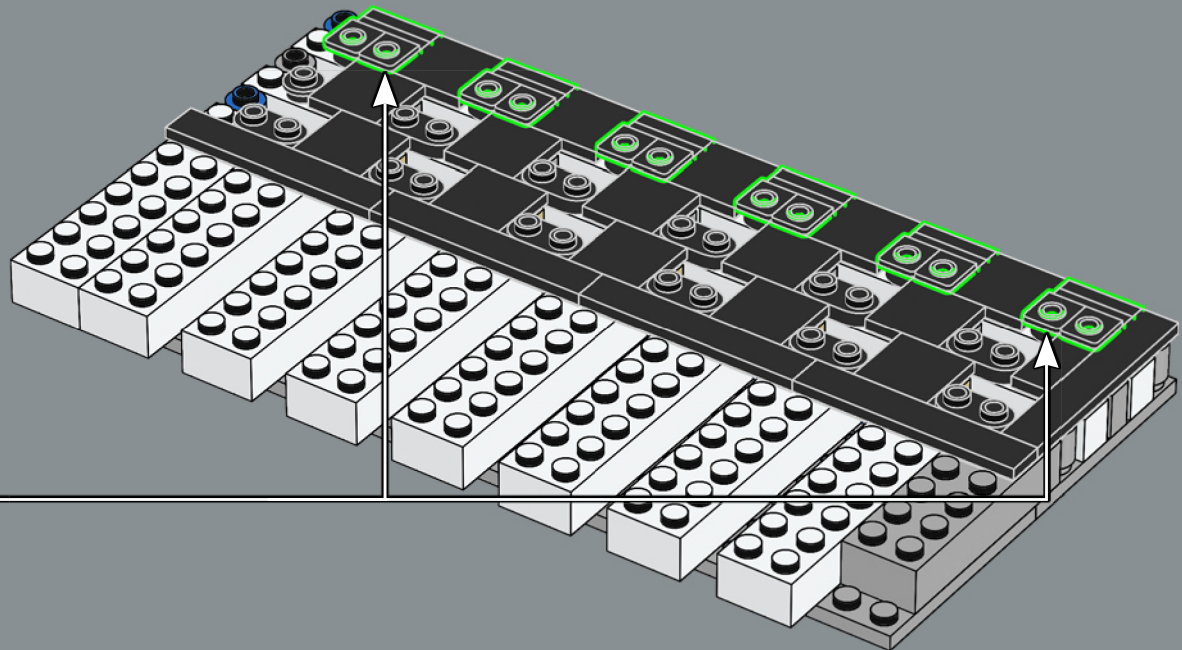

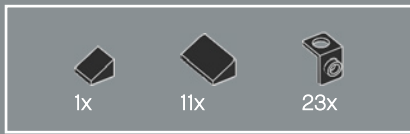

64

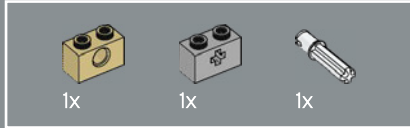
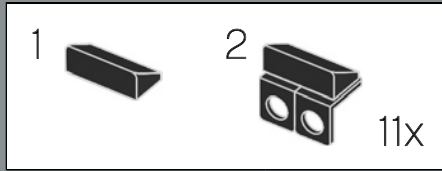
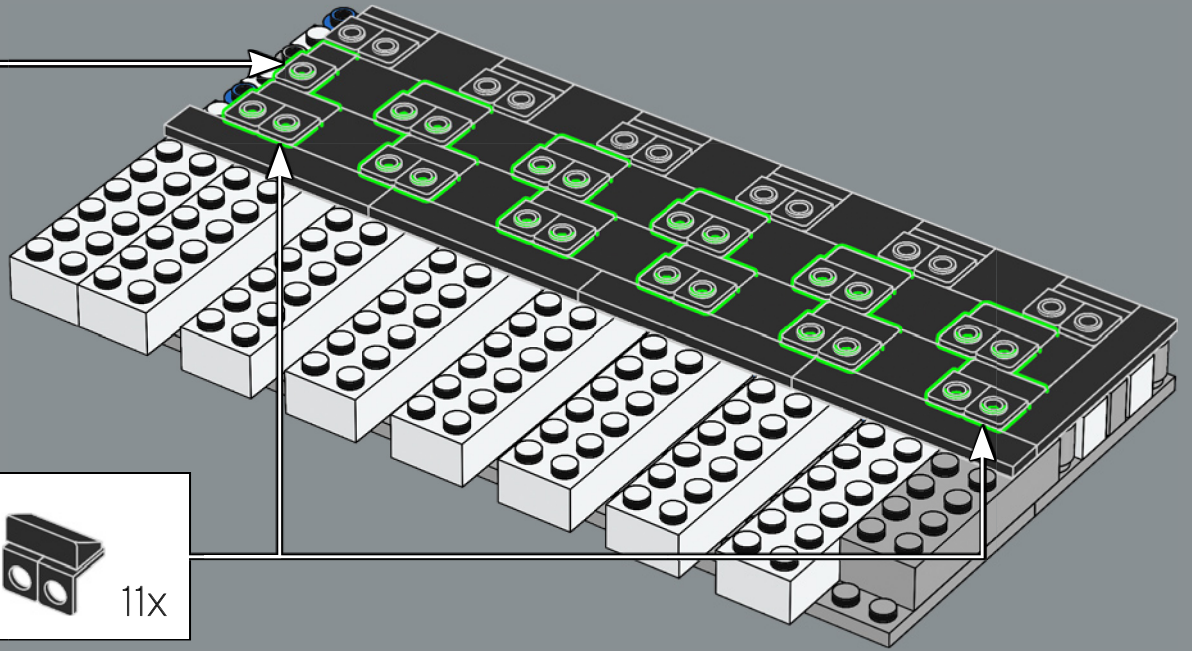
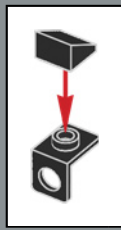

65

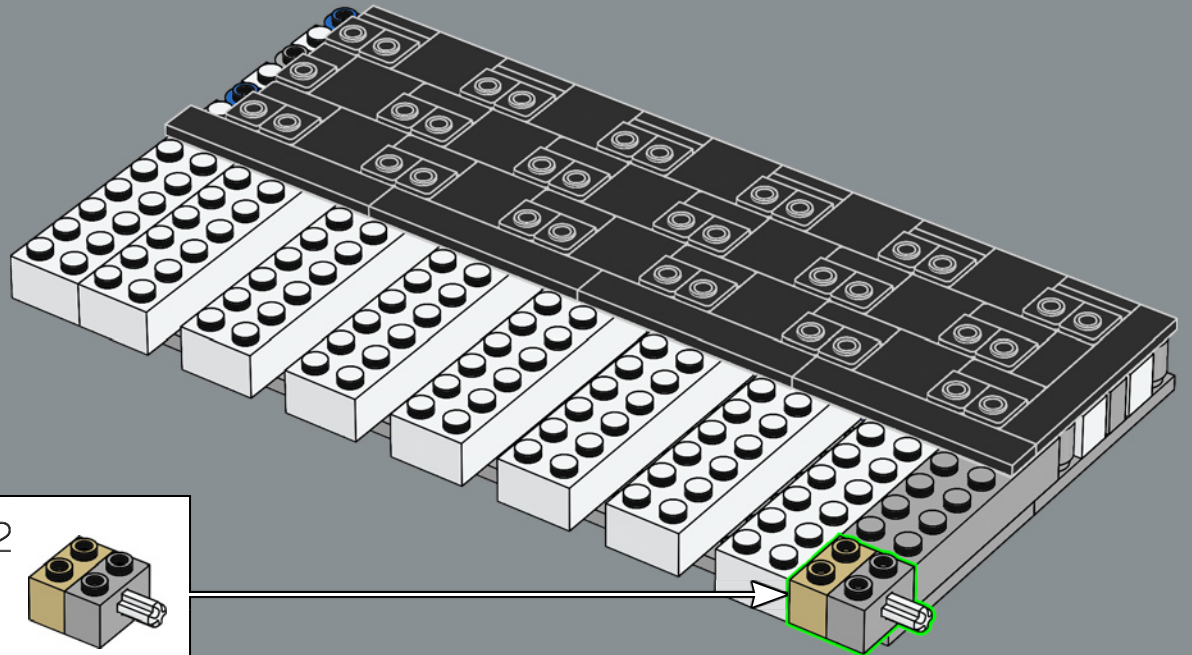
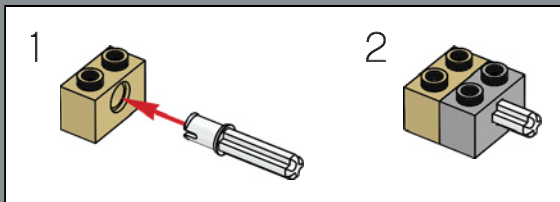

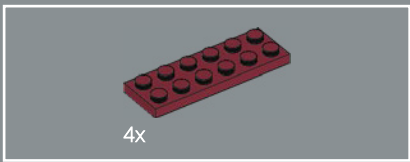

66

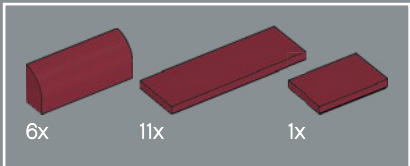
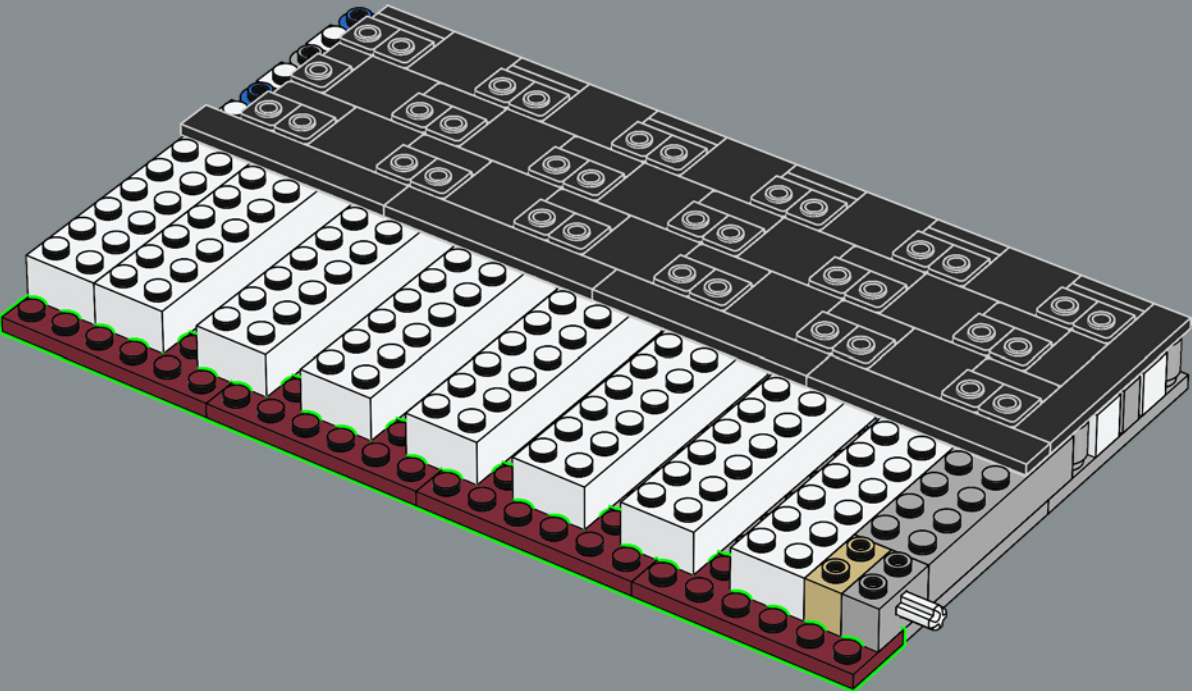

67

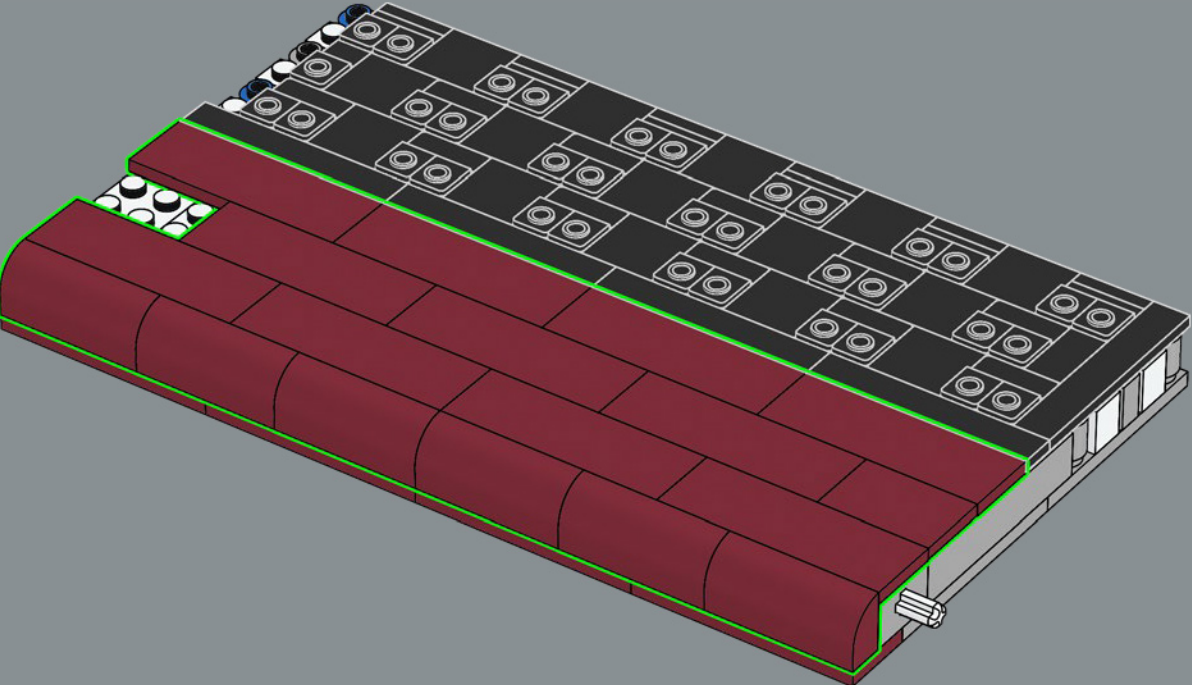

68

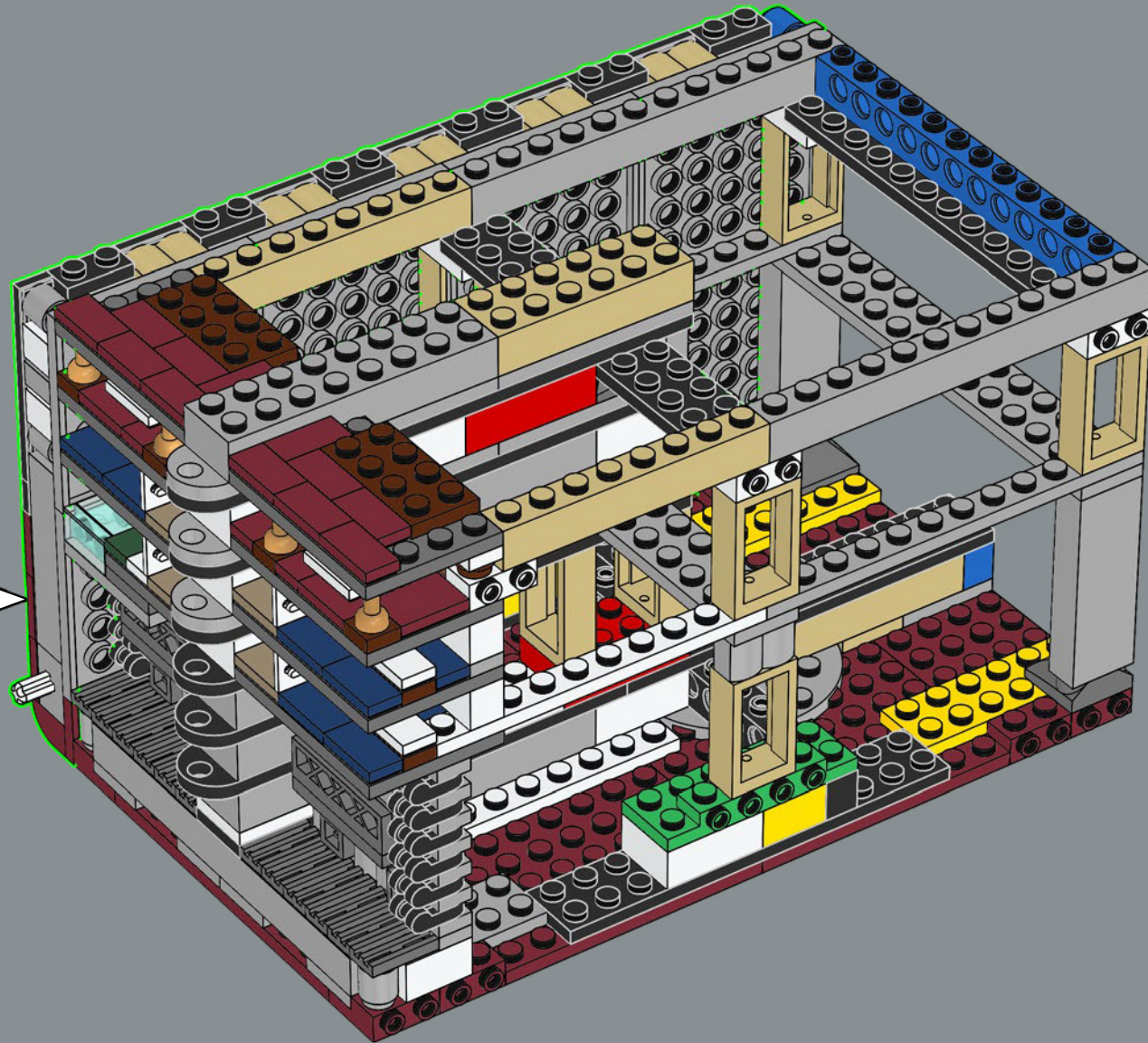

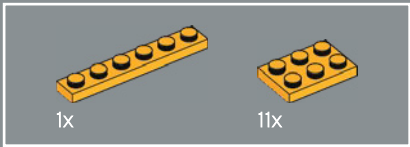

69

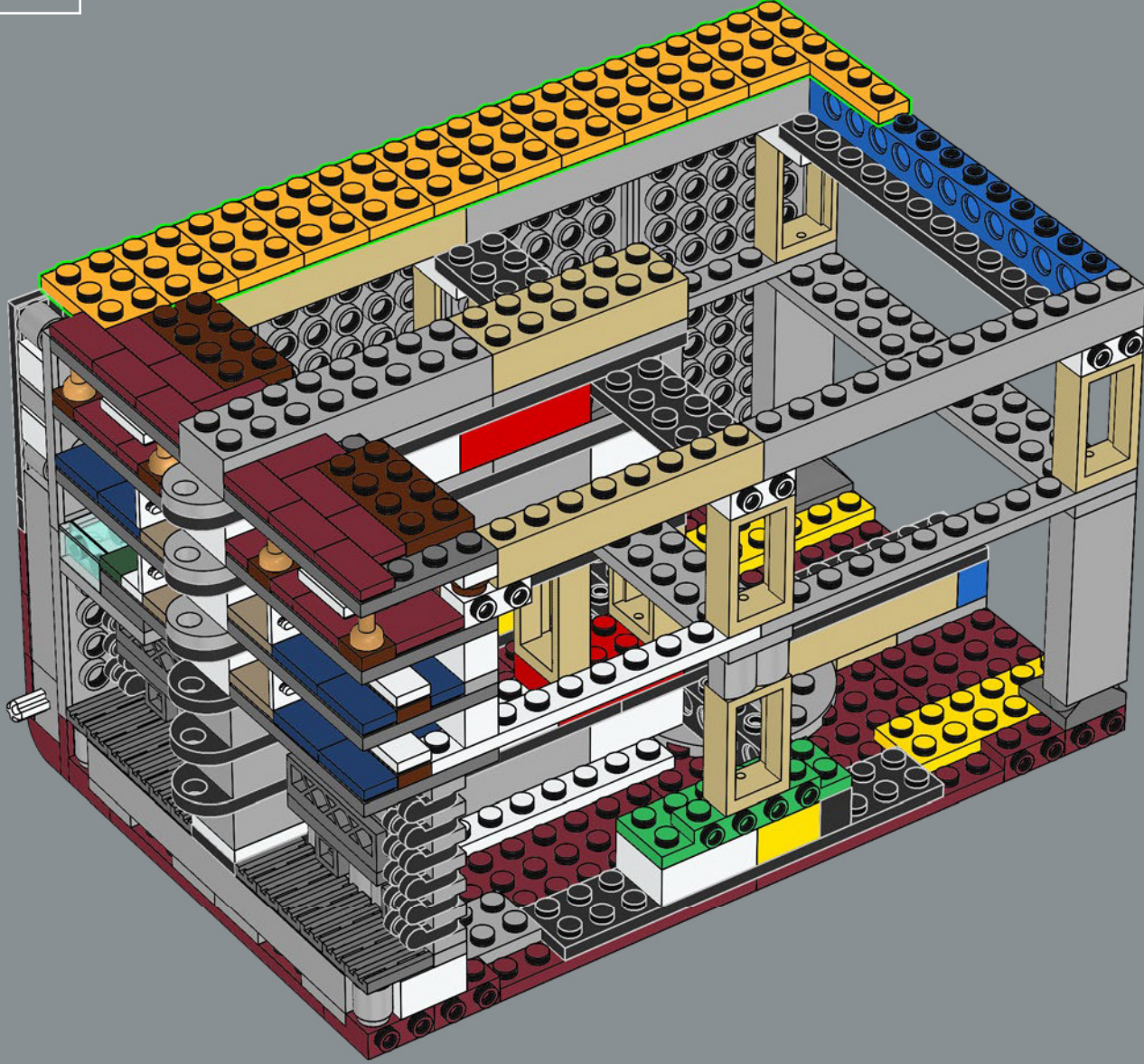

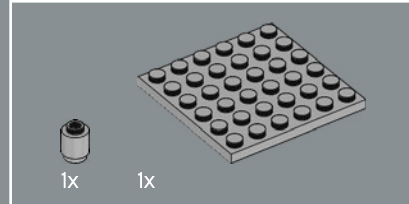
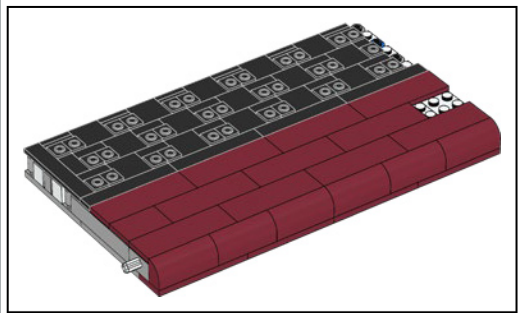
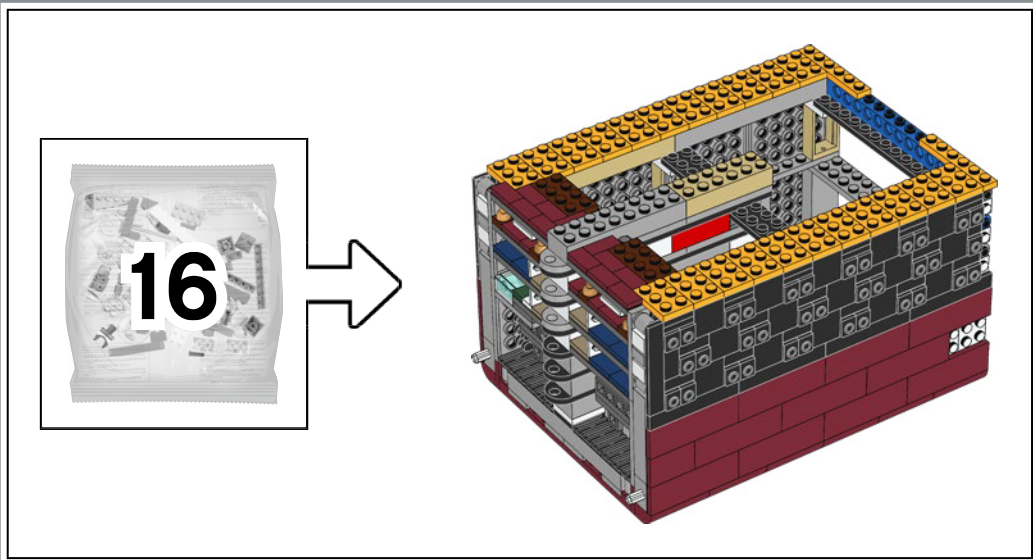

70

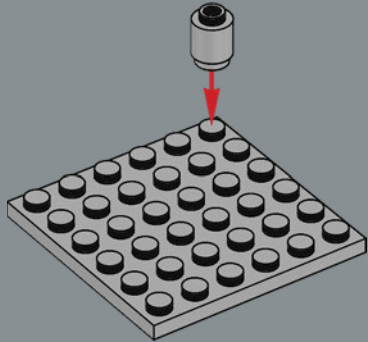

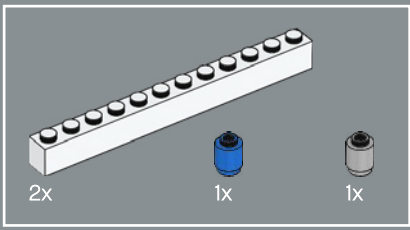

71

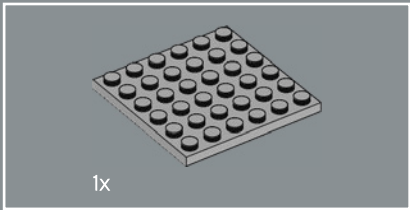
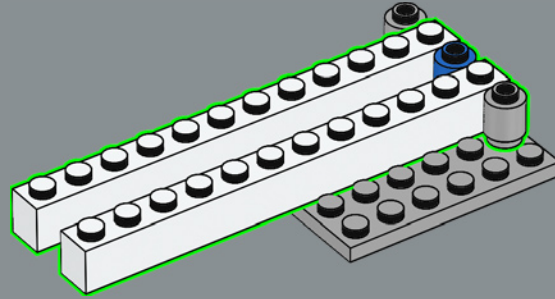

72

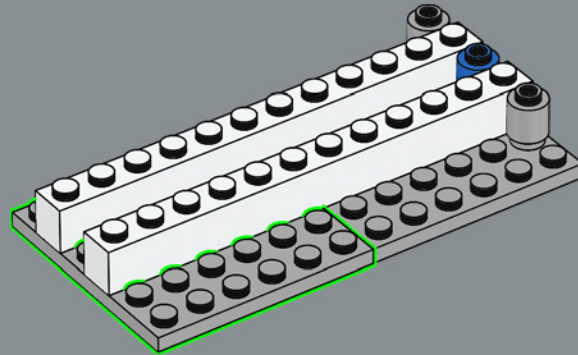

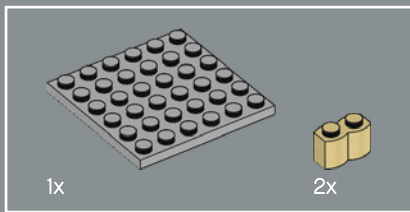

73

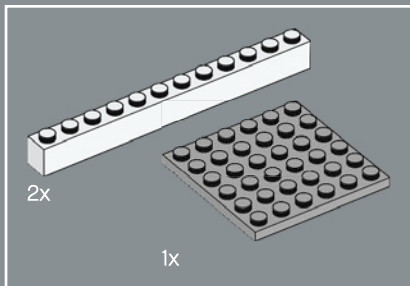
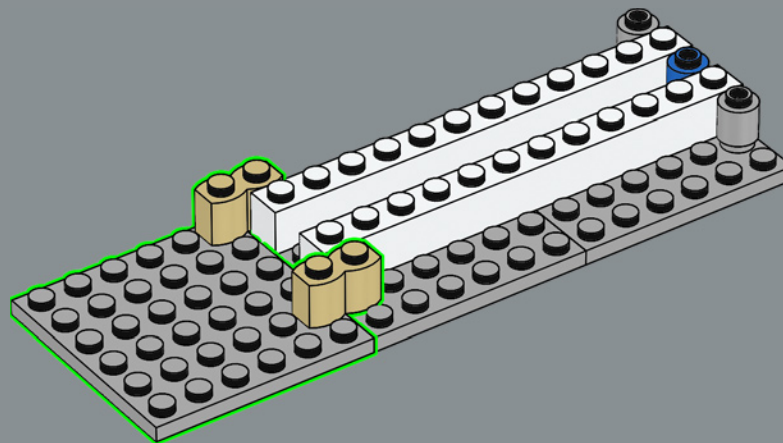

74

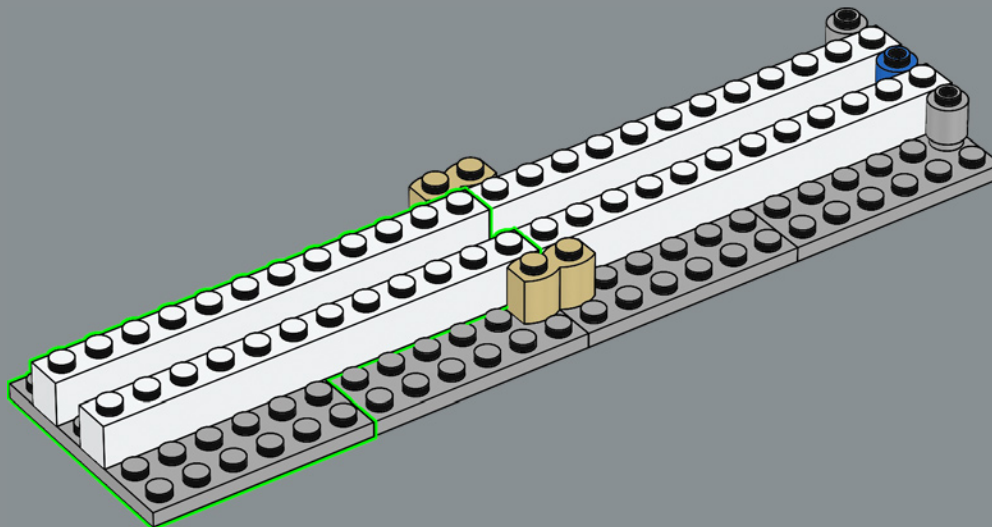

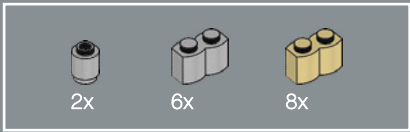

75

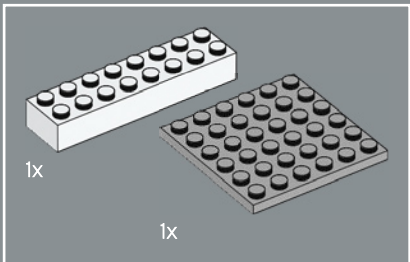
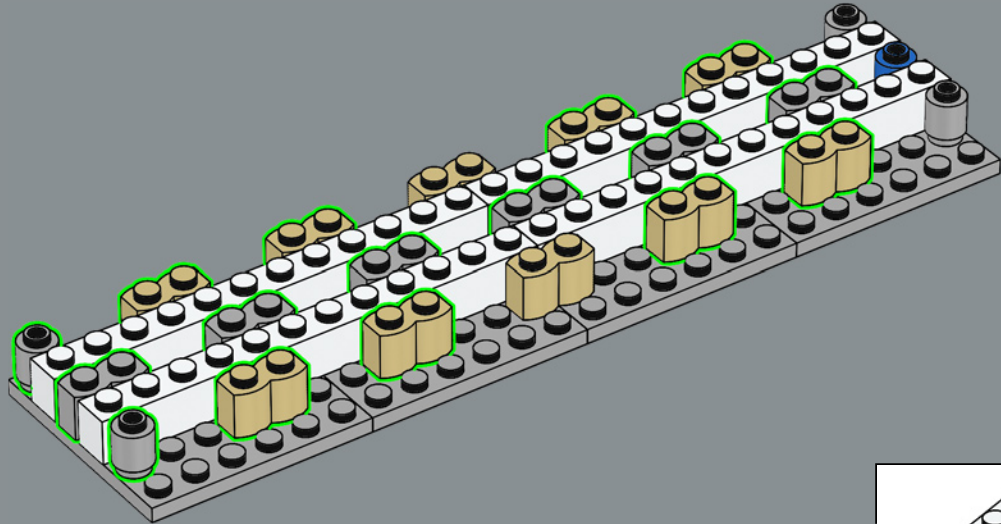

76

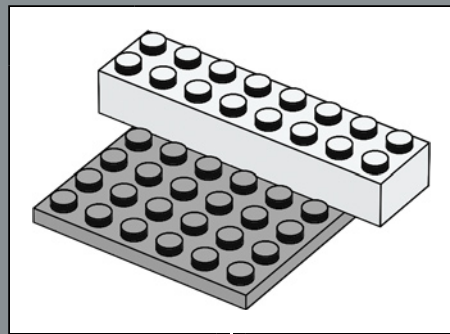
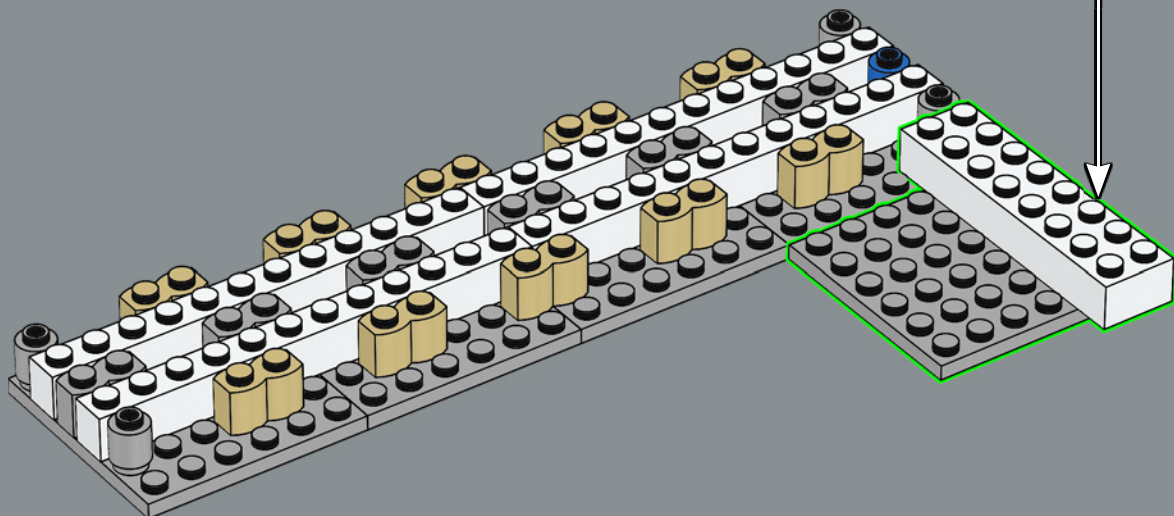

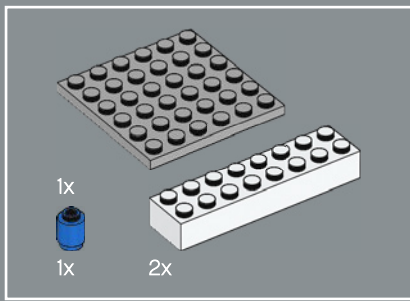

77

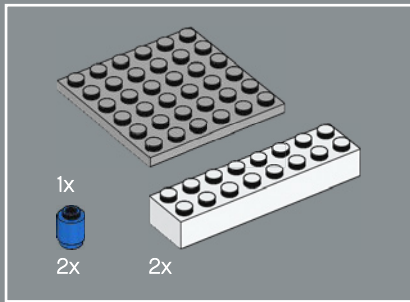
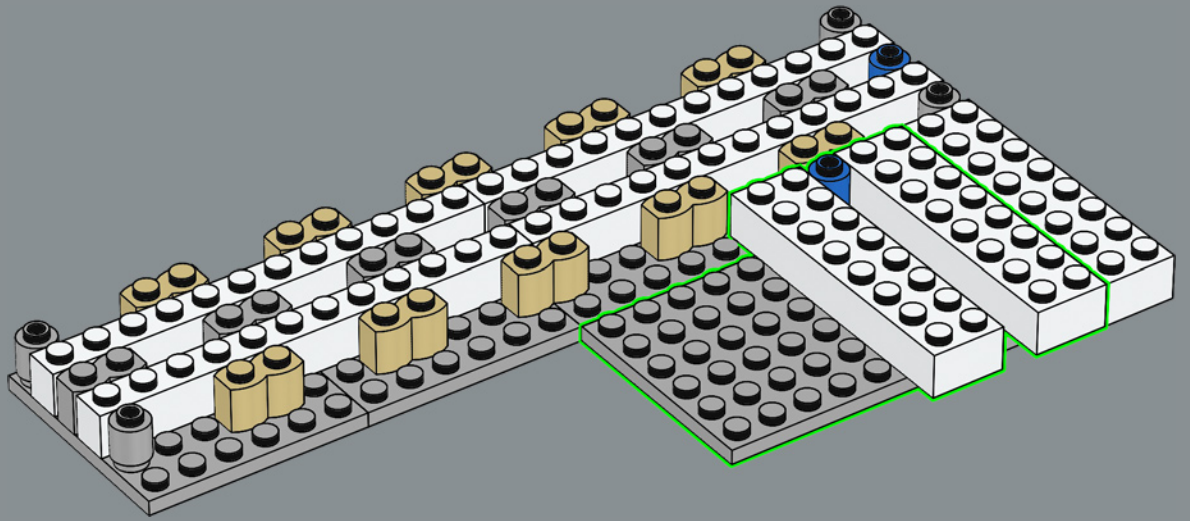

78

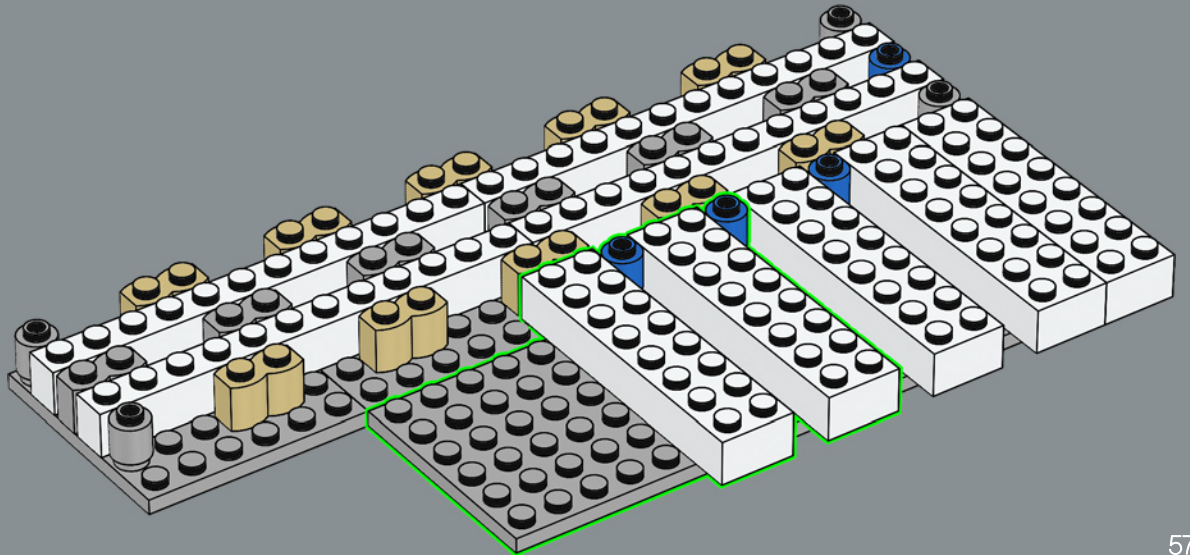

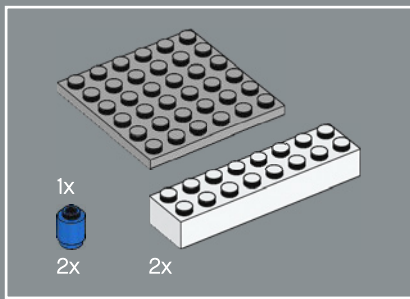

79

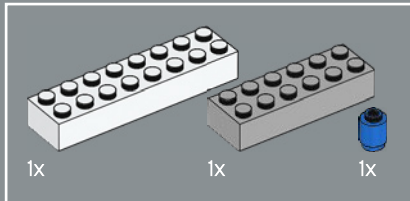
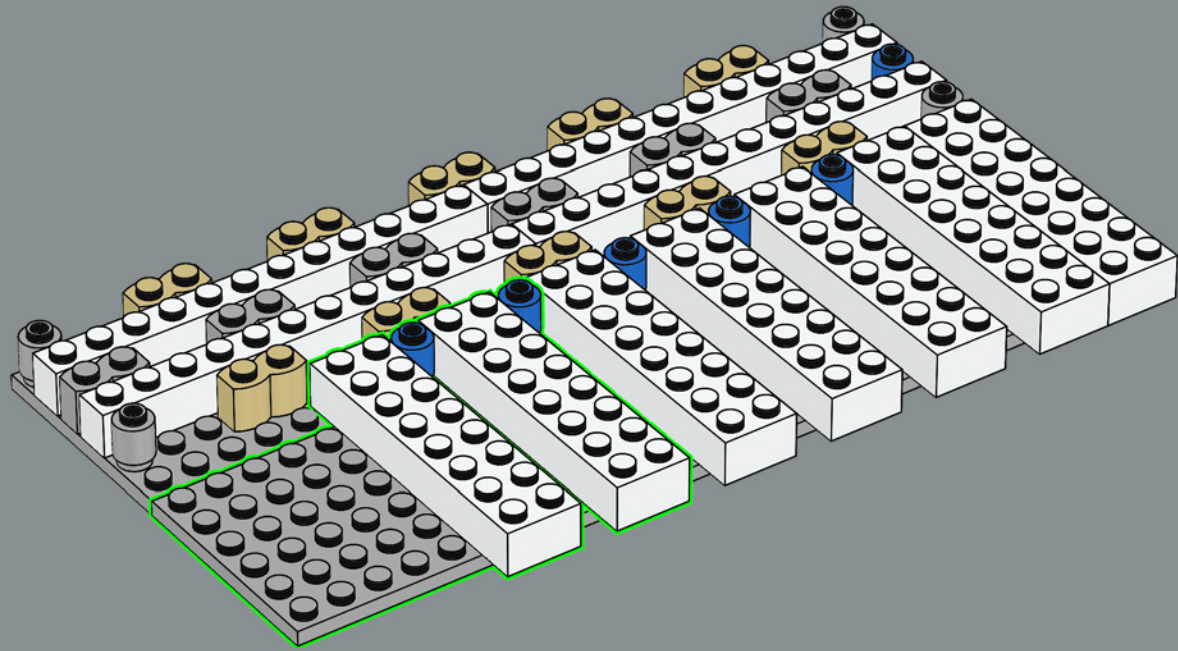

80

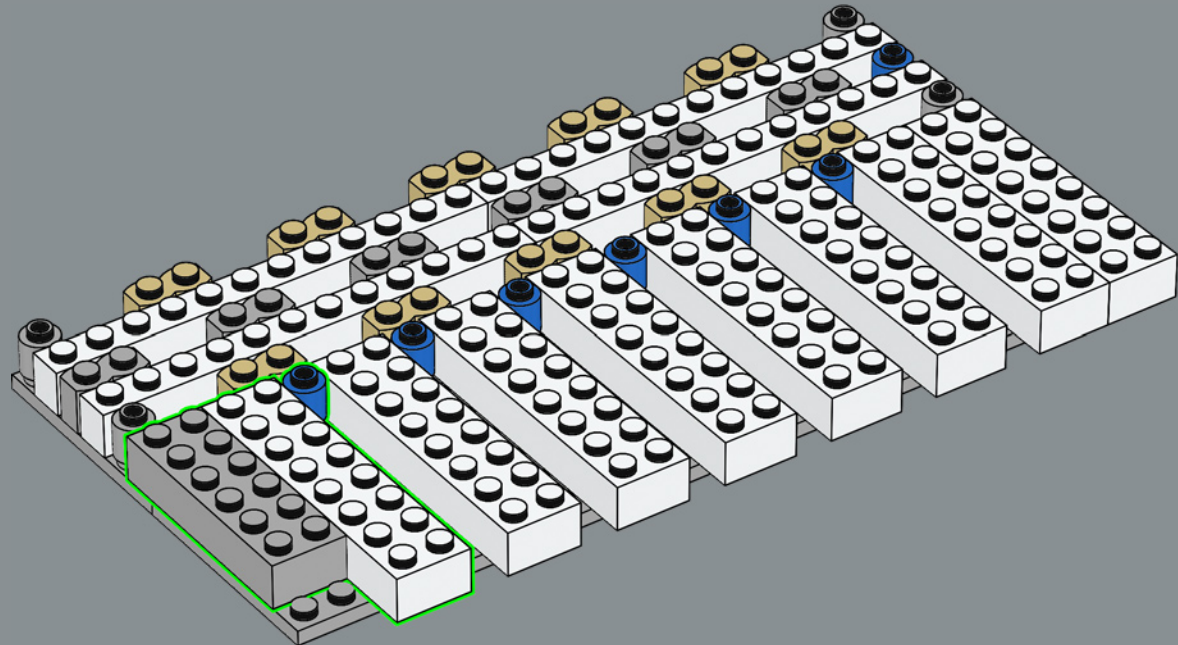

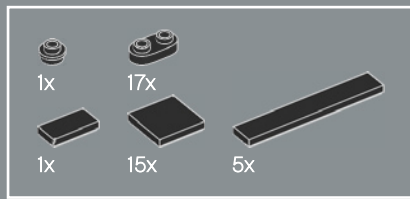

81

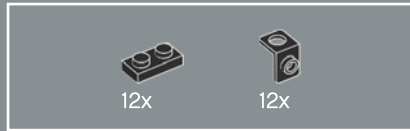
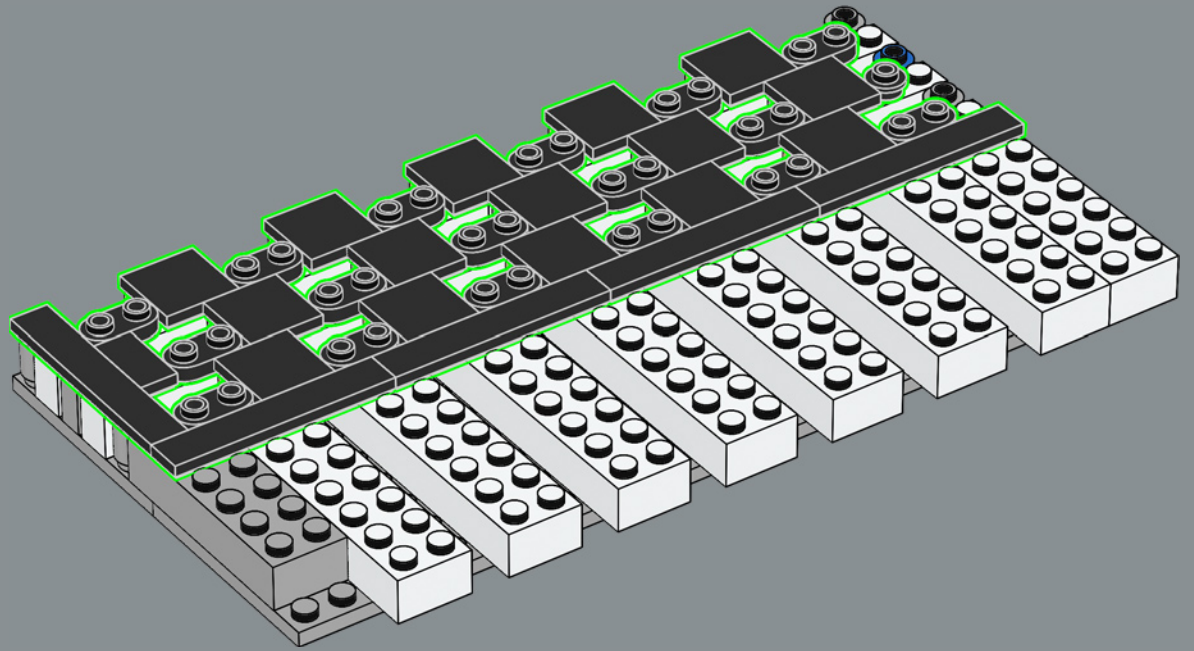

82

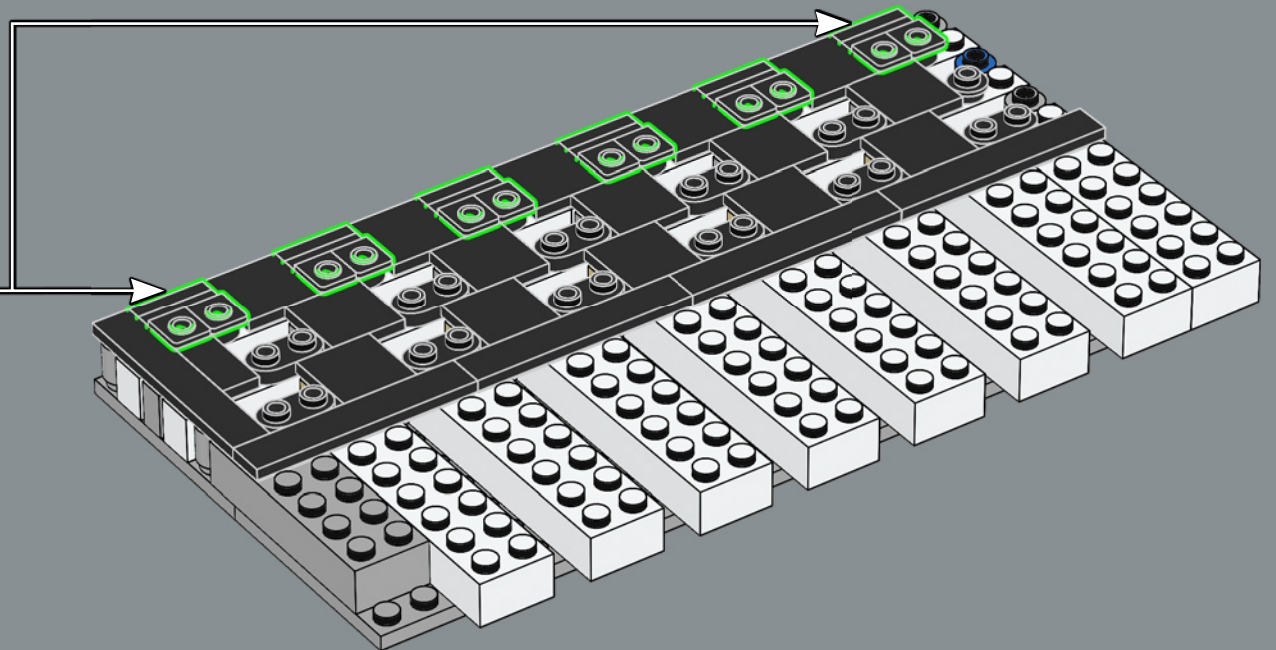
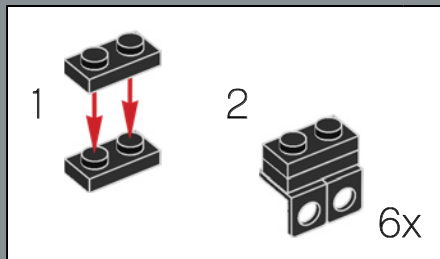



83

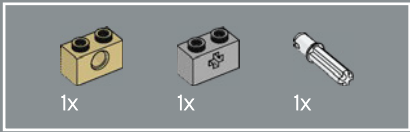
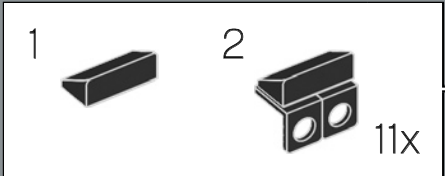
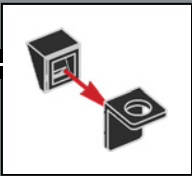
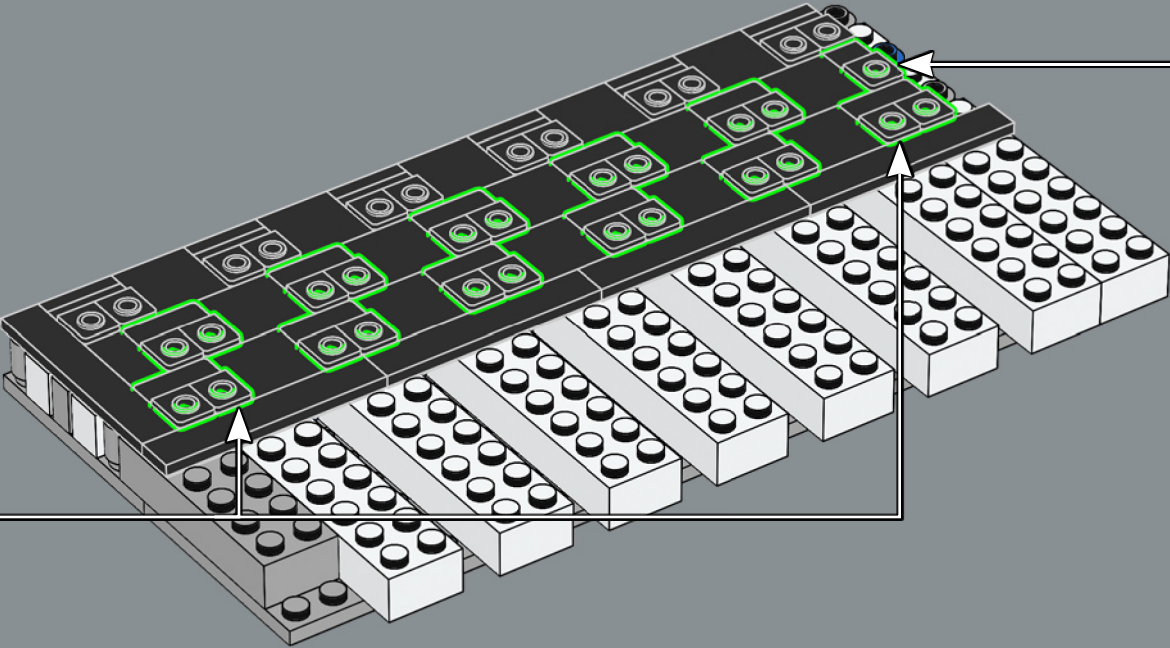

84

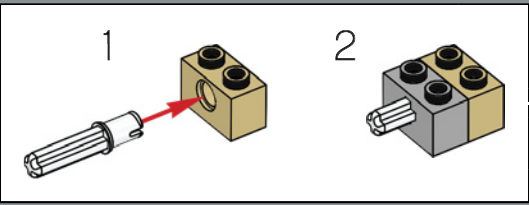
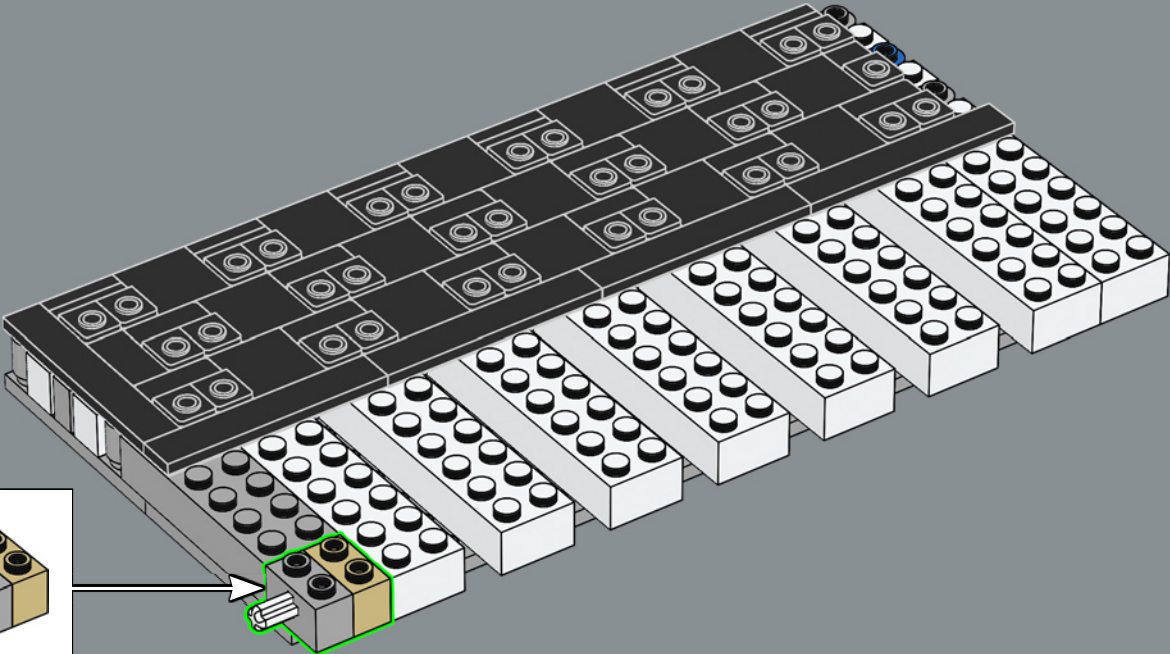

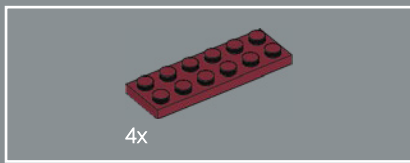

85

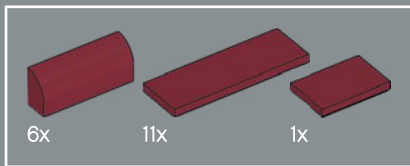
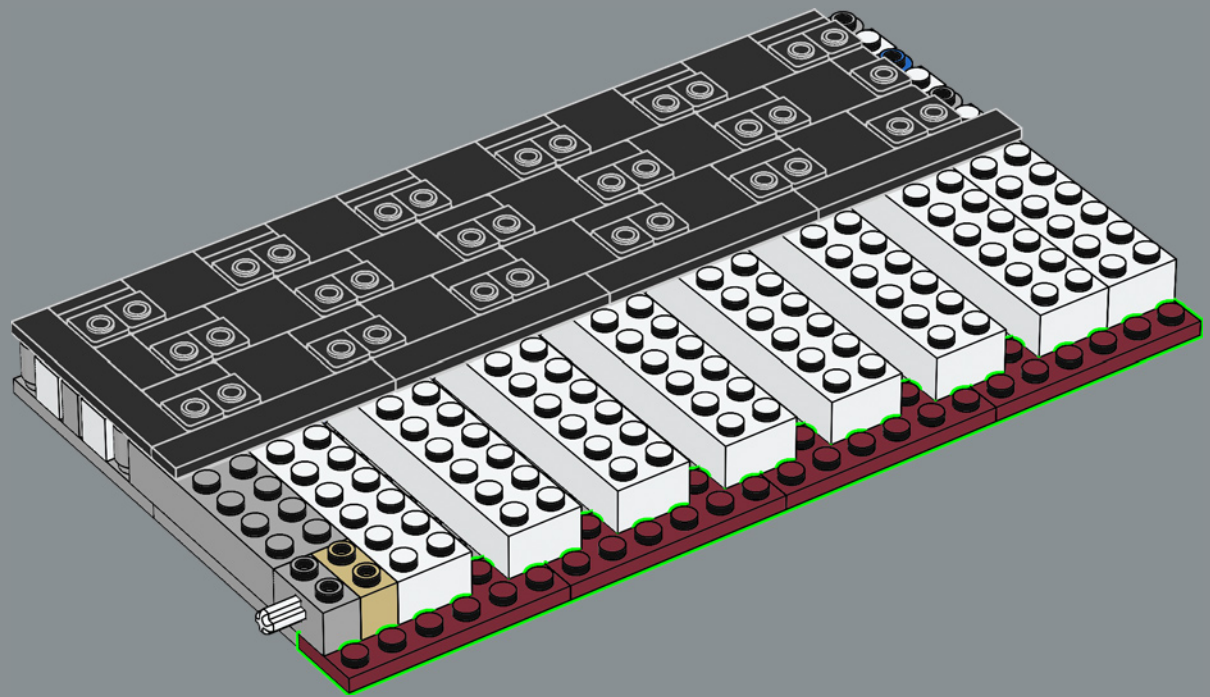

86

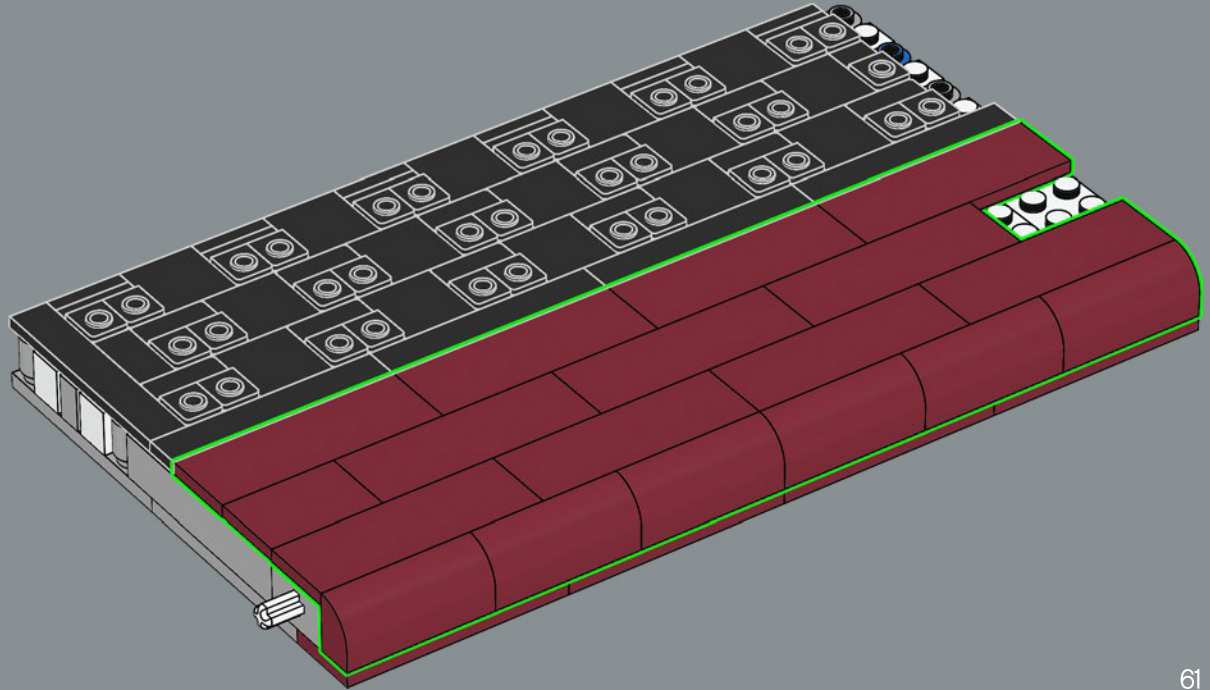

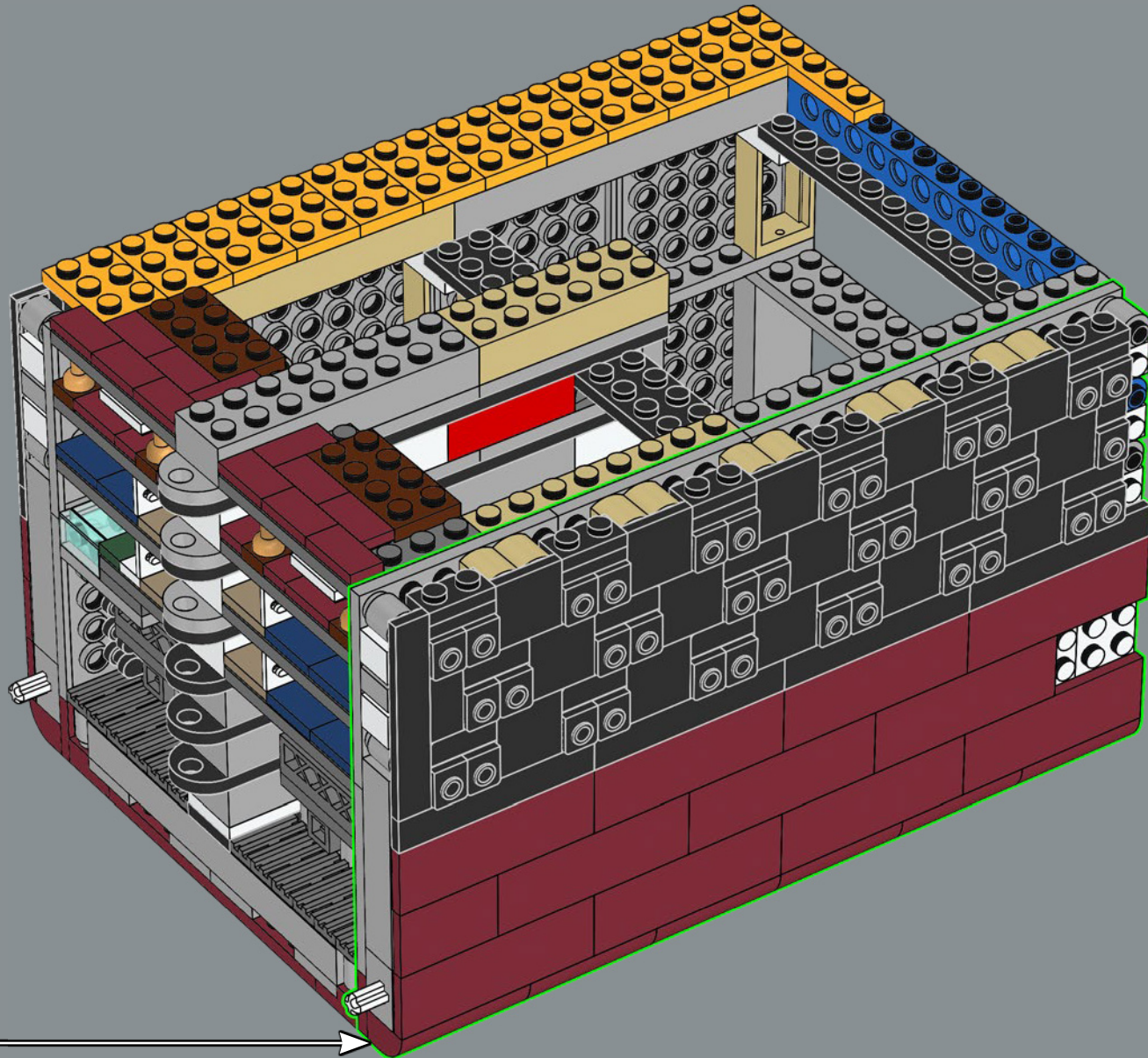

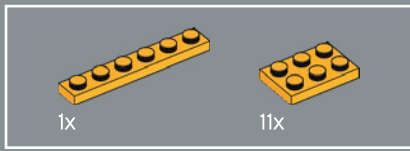

88

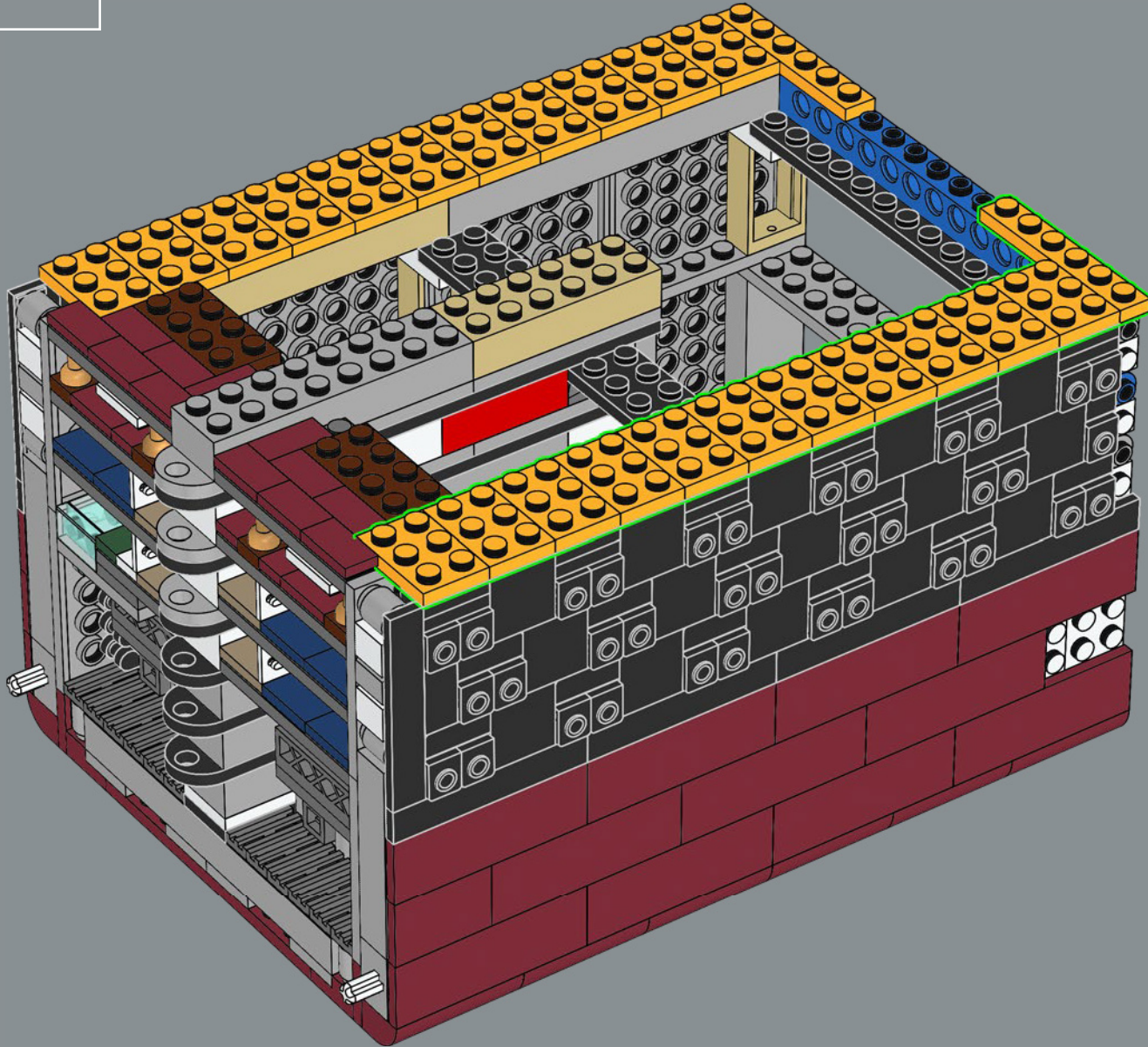

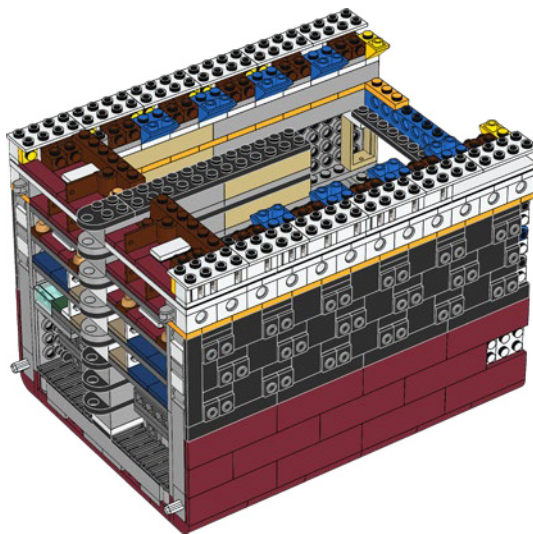
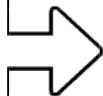

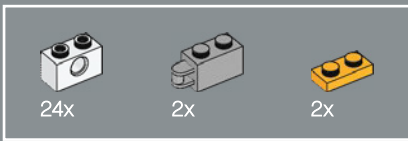

89

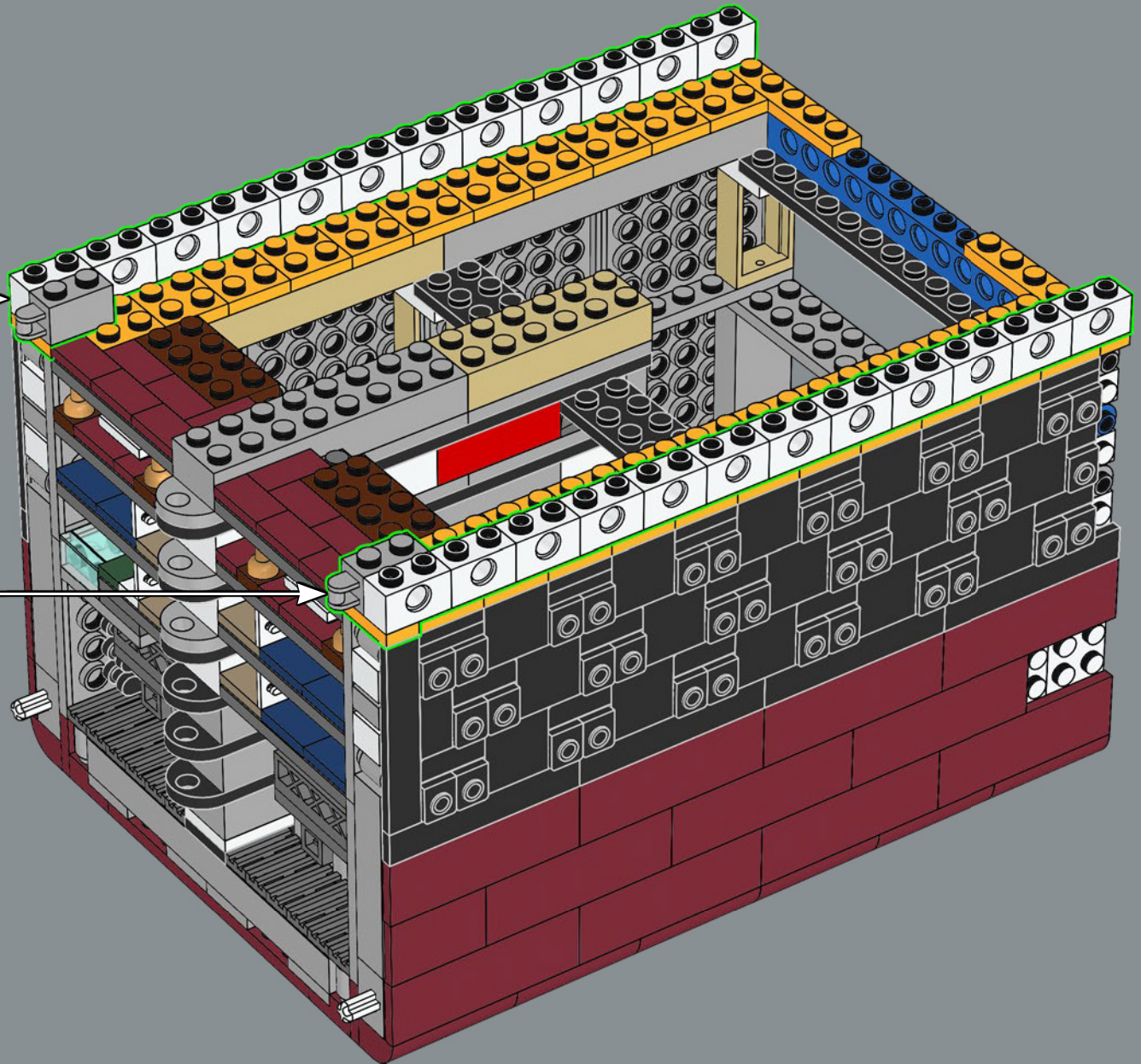
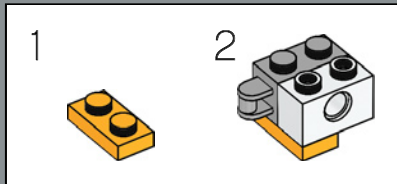
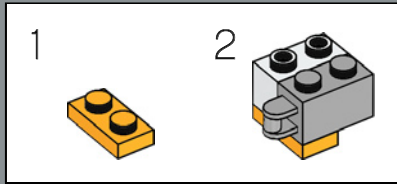

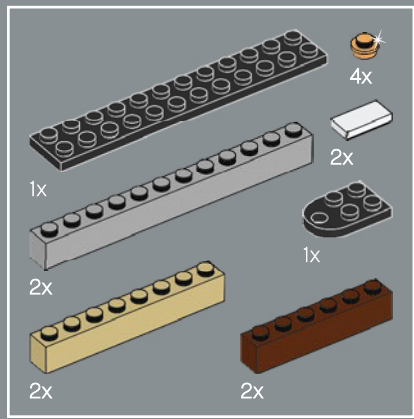

90

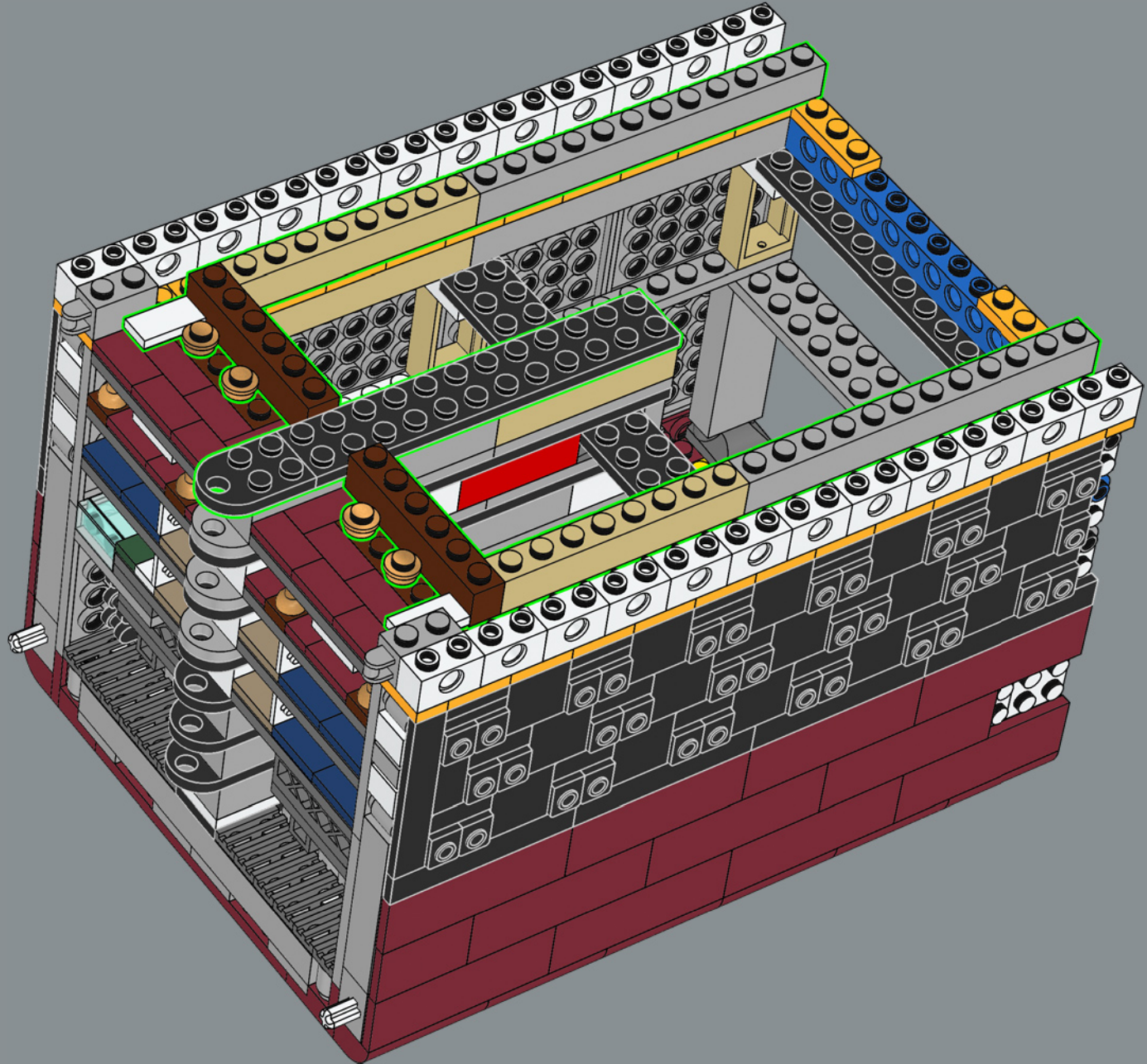

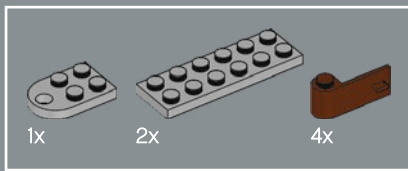

91

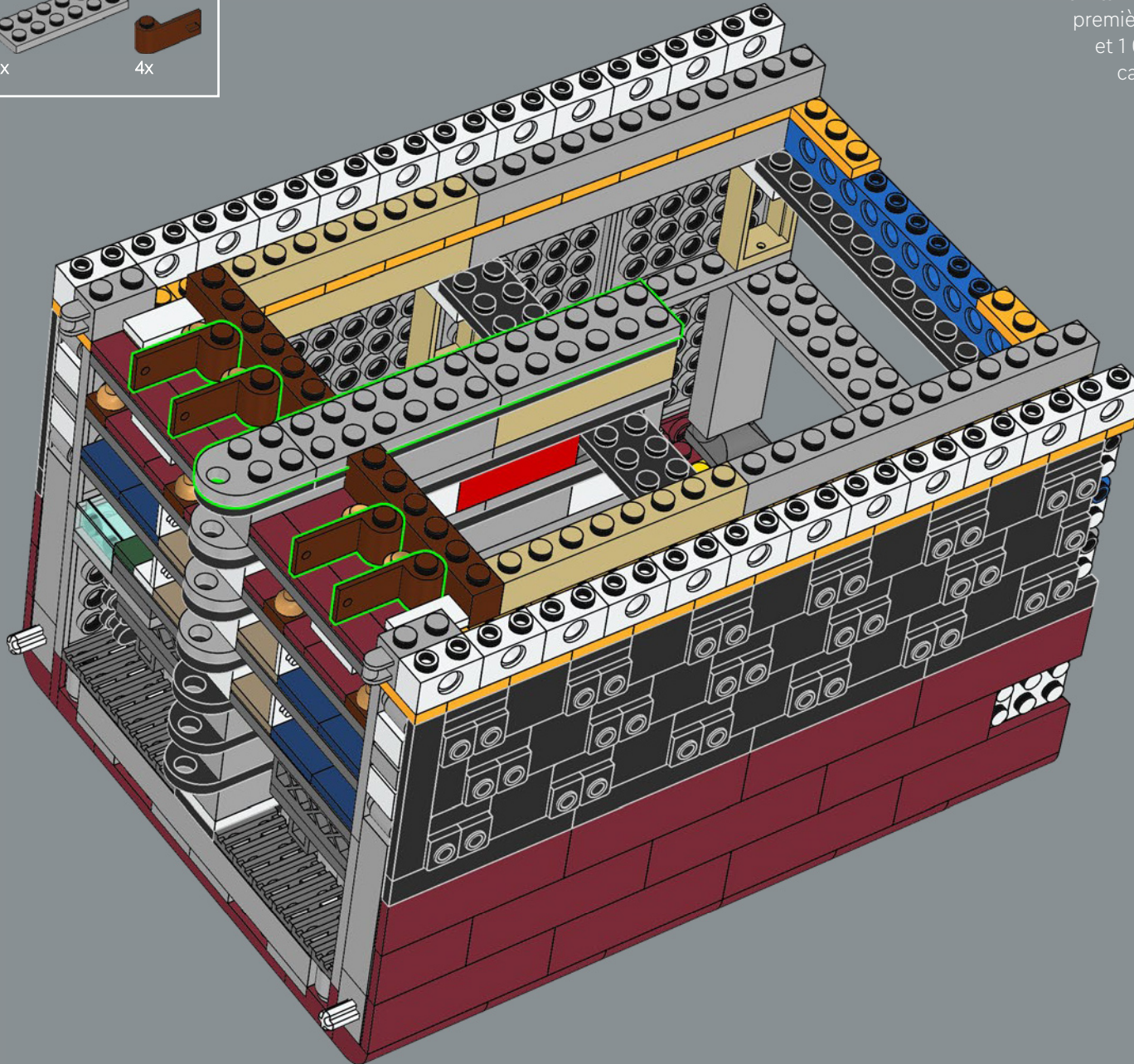

Le Titanic peut accueillir 833 passagers en première classe, 614 en deuxième classe et 1 006 en troisième classe, pour une capacité totale de 2 453 passagers.

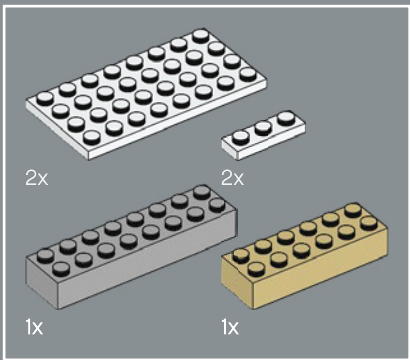

92

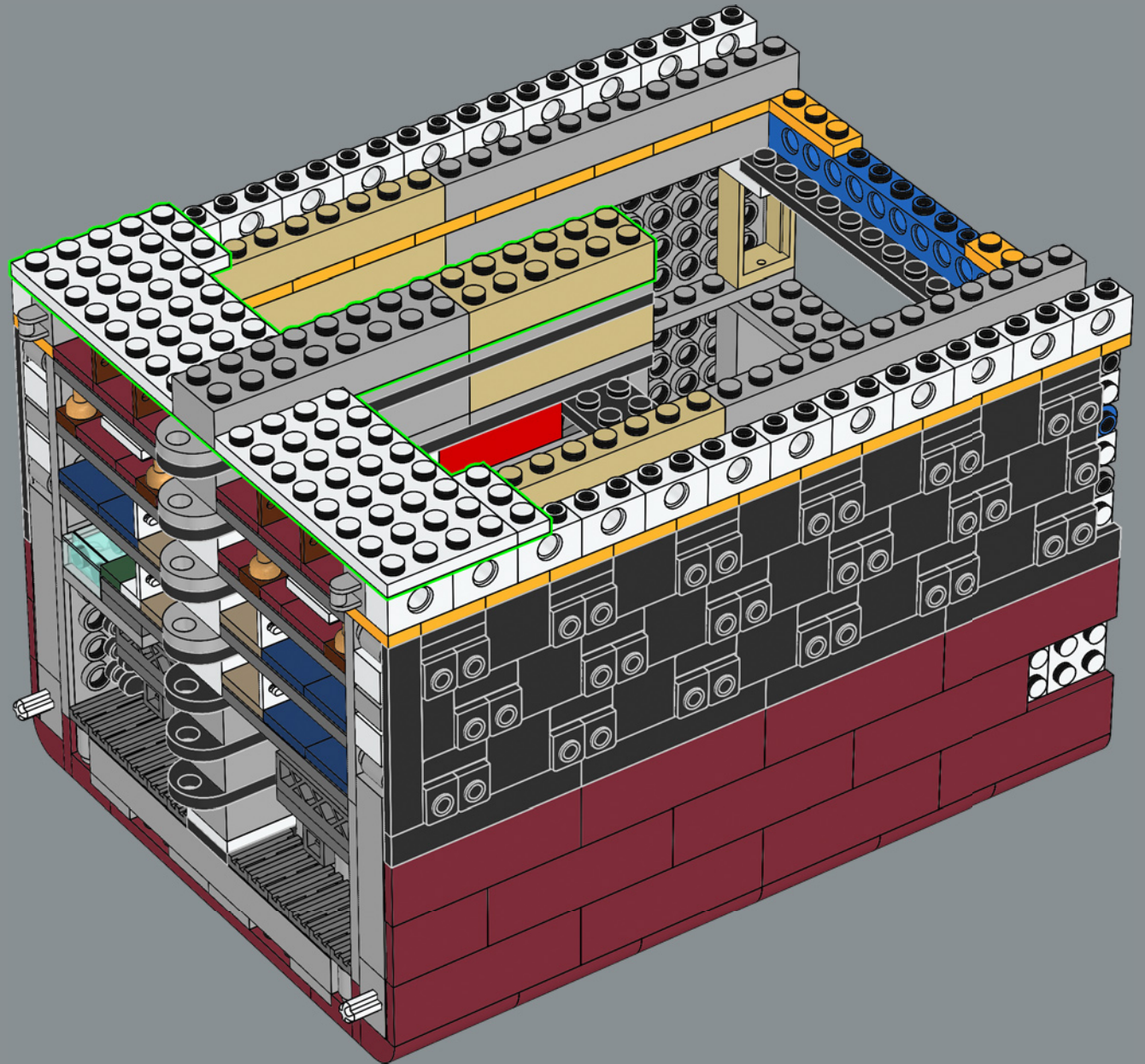

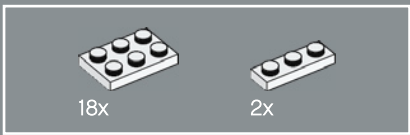

93

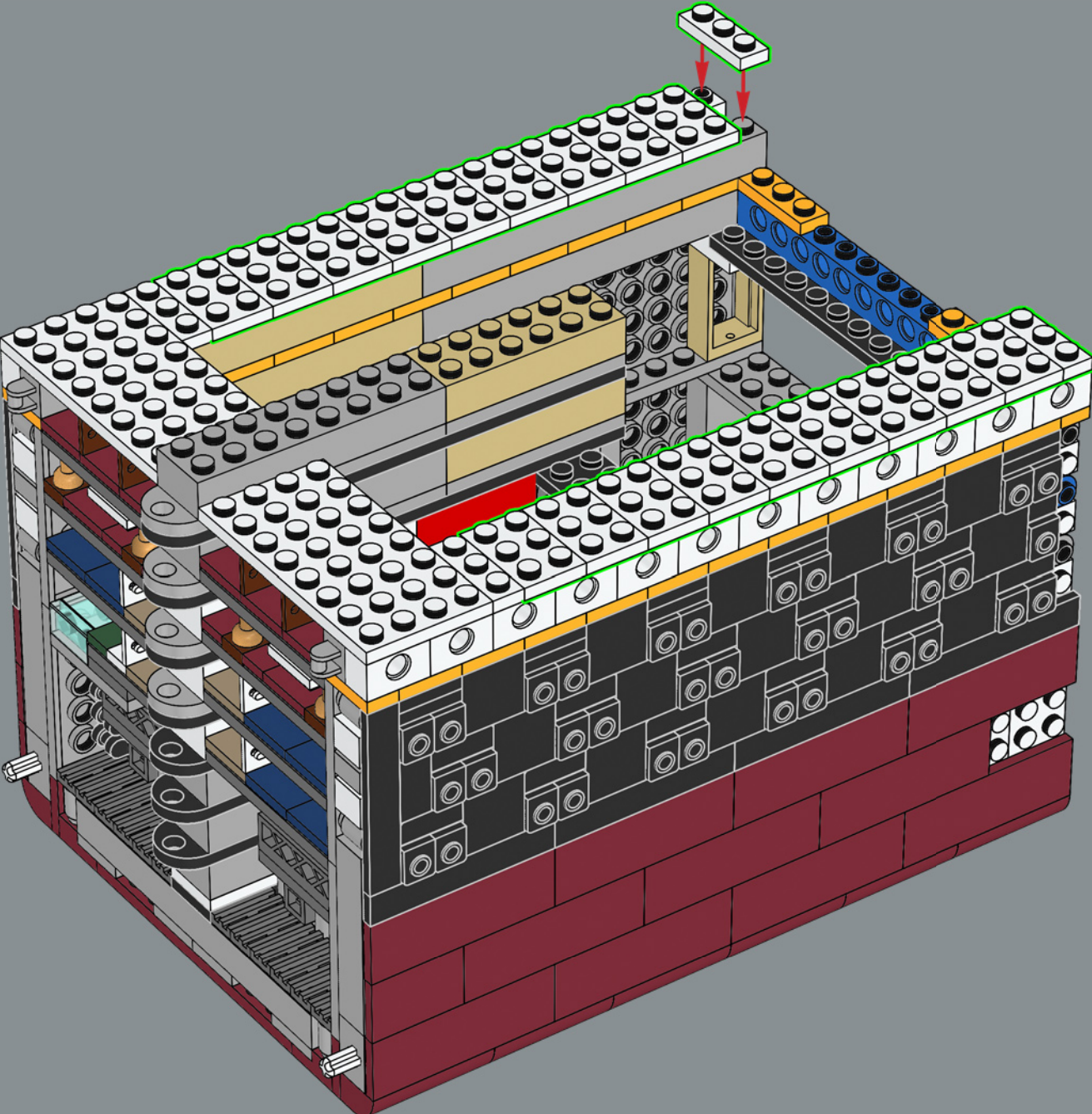

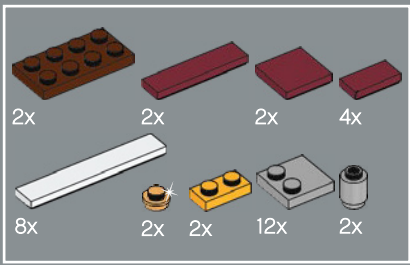

94

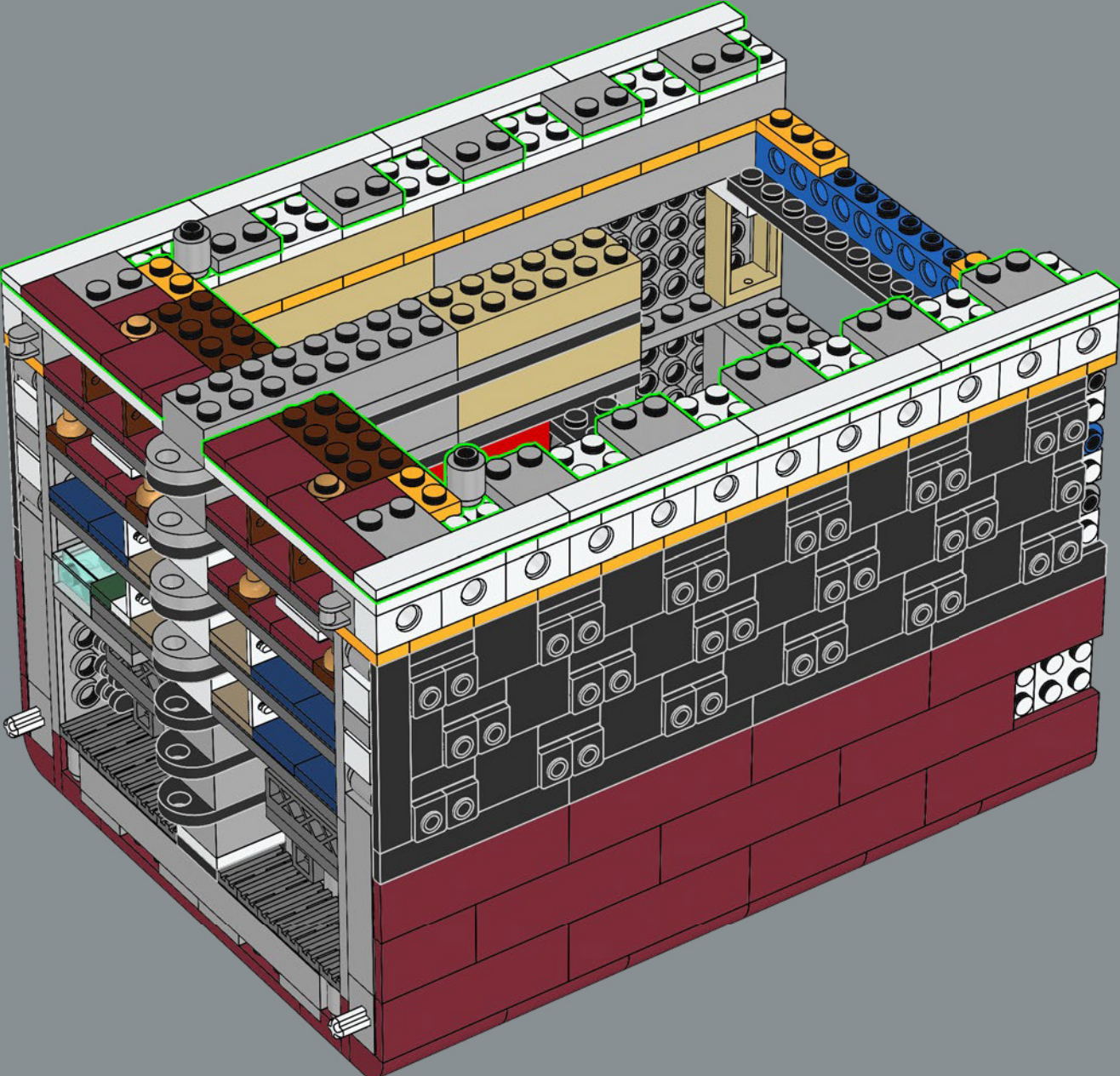

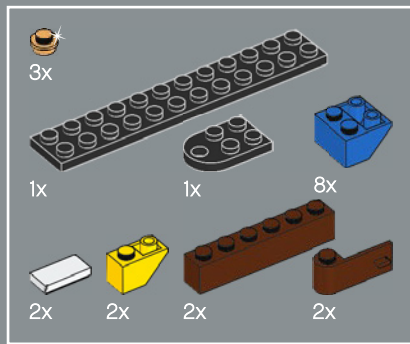

95

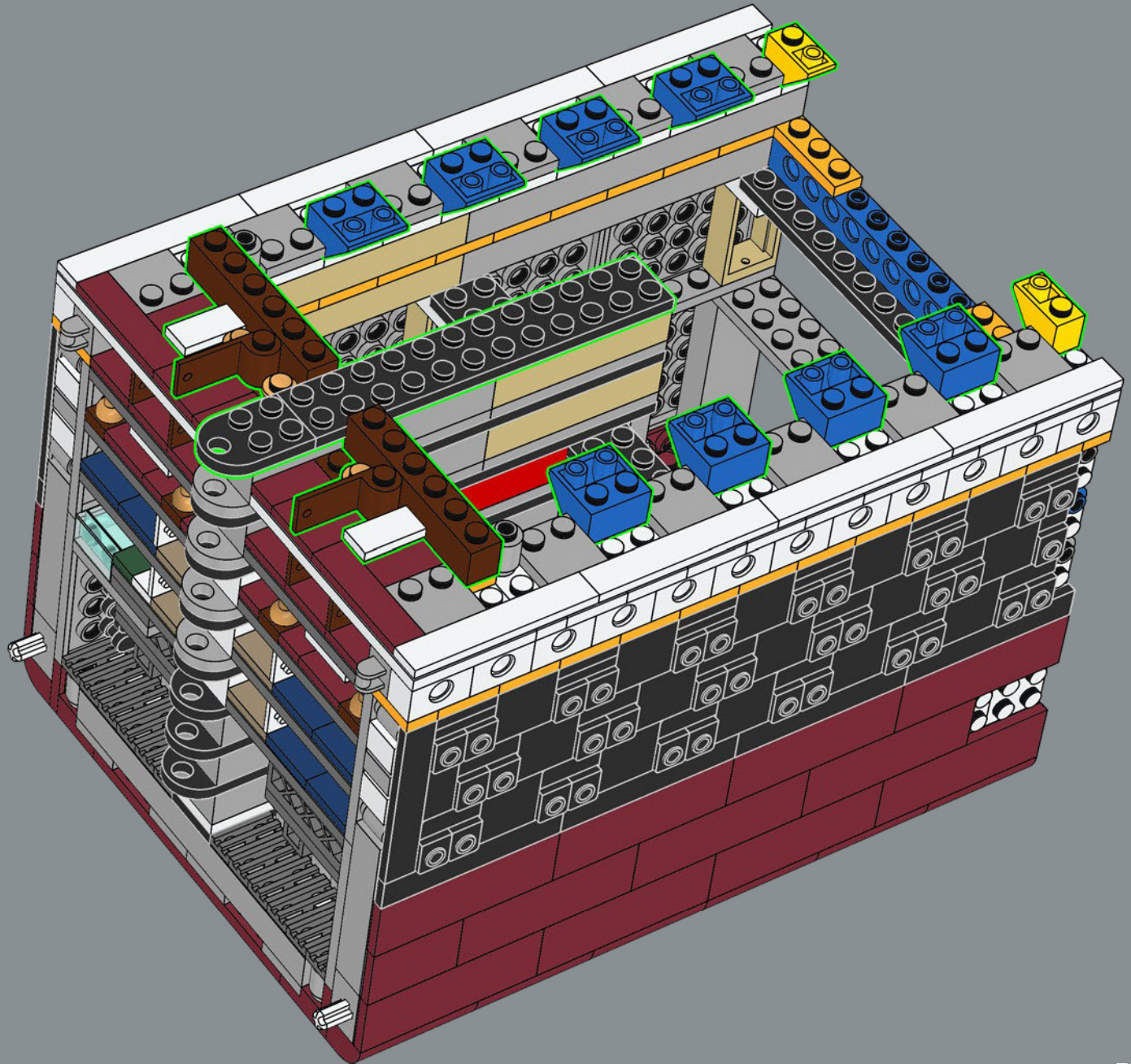

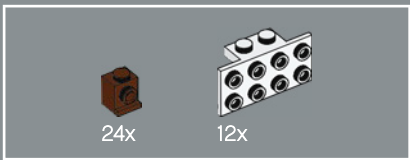

96

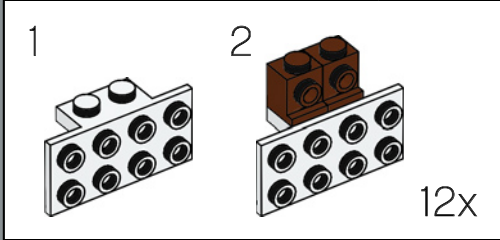
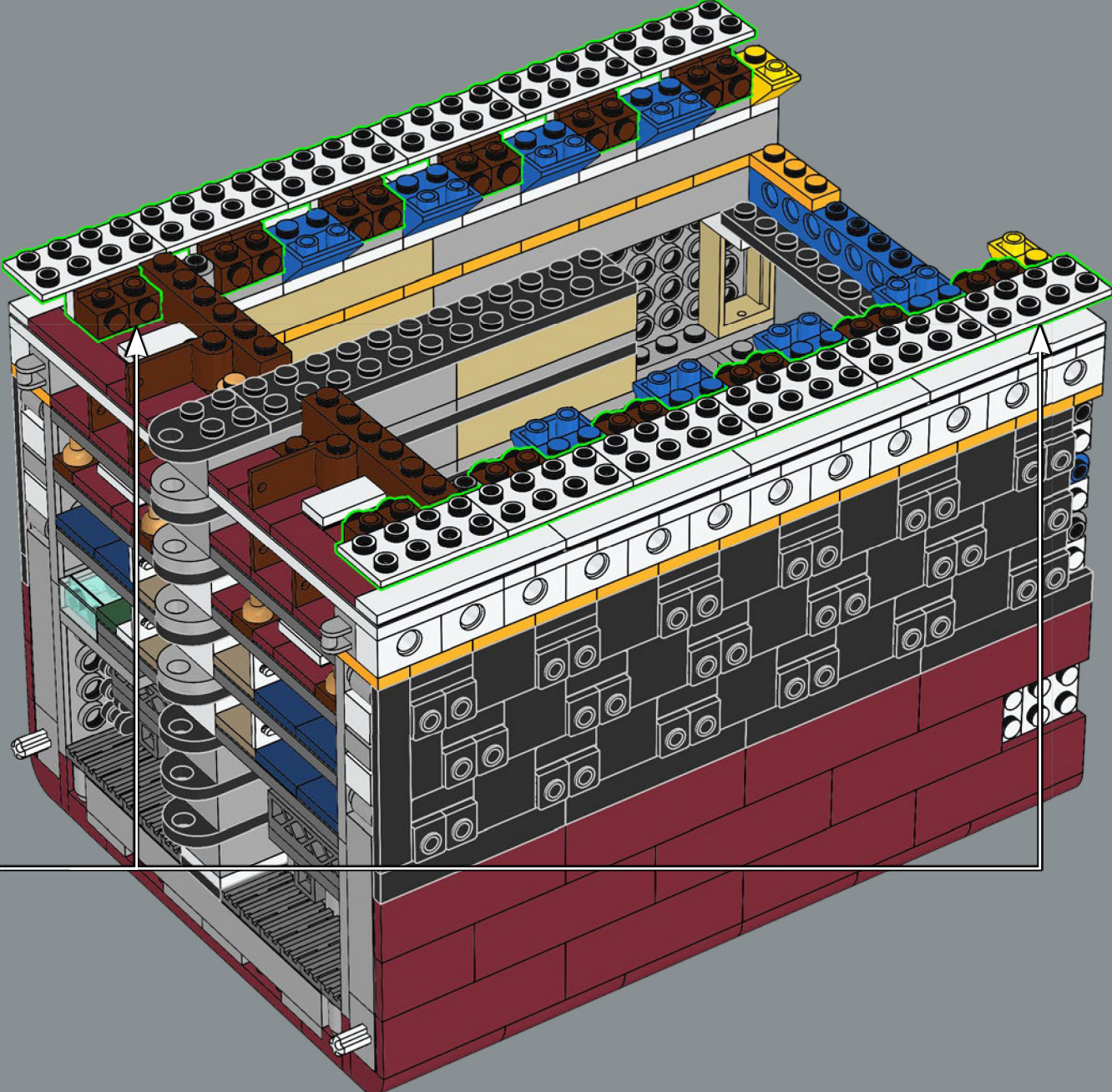

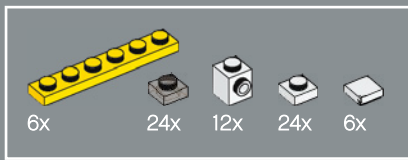

97

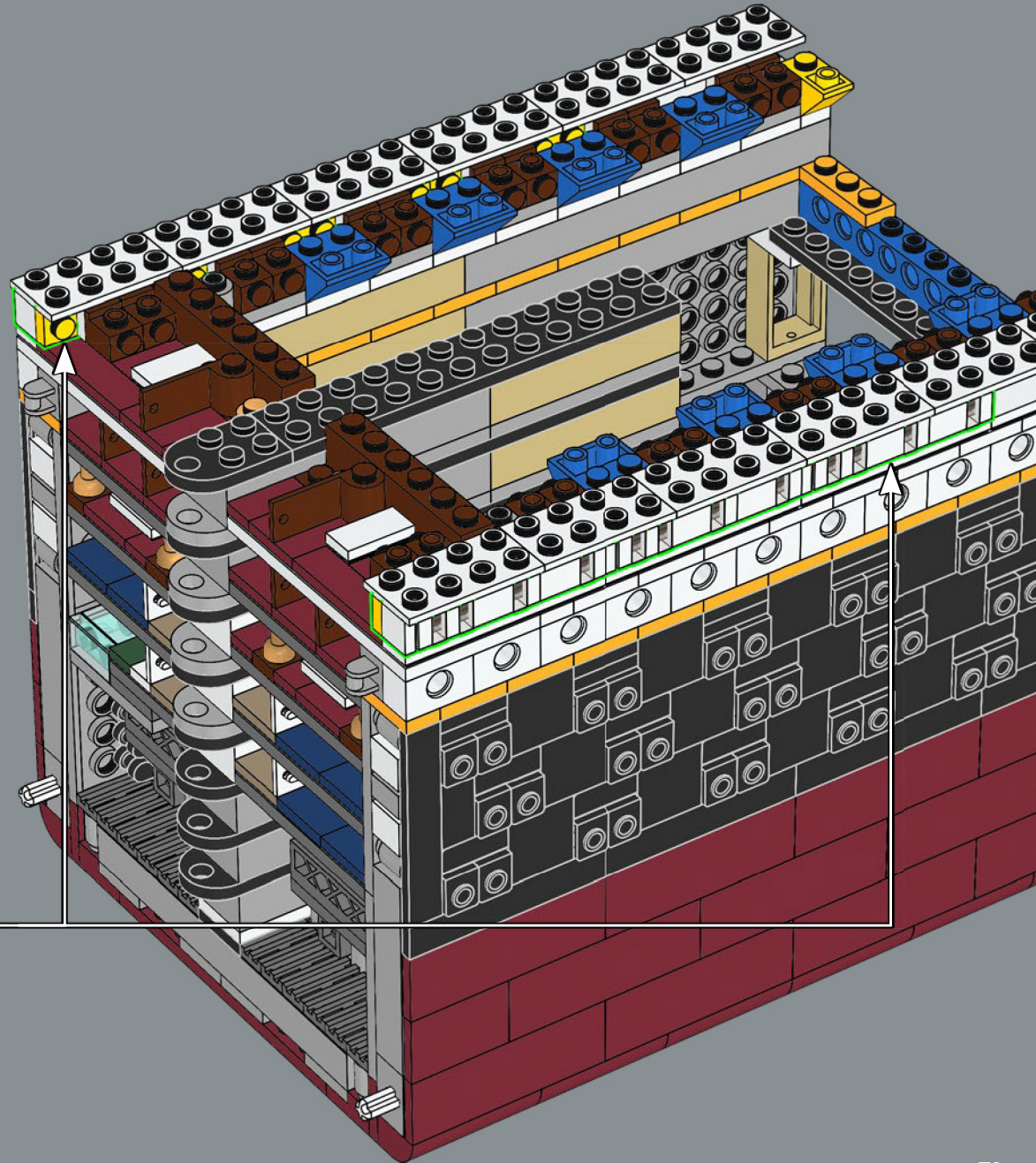
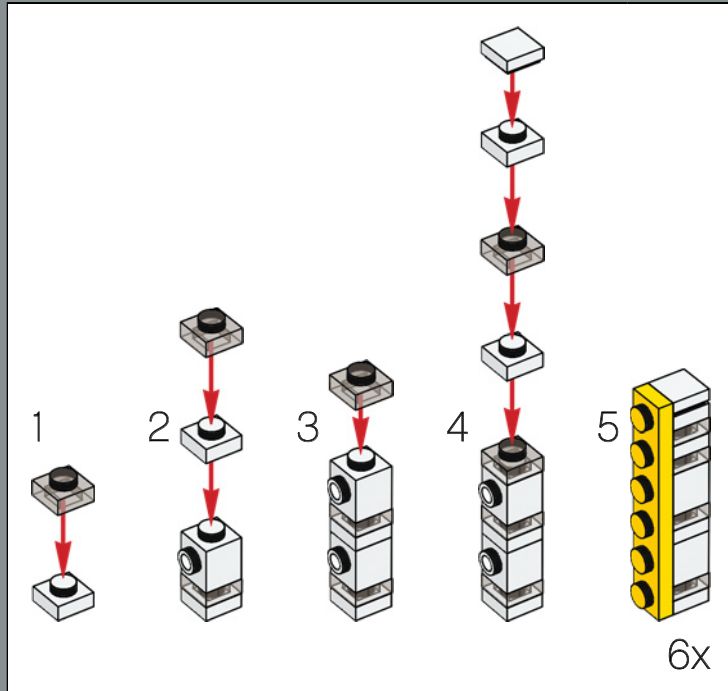

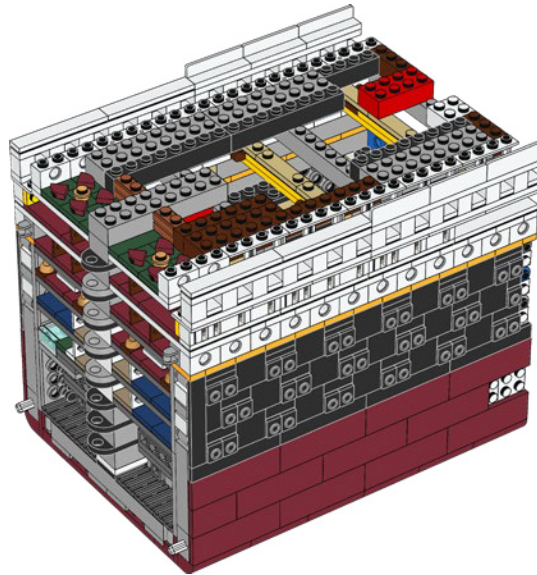
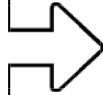

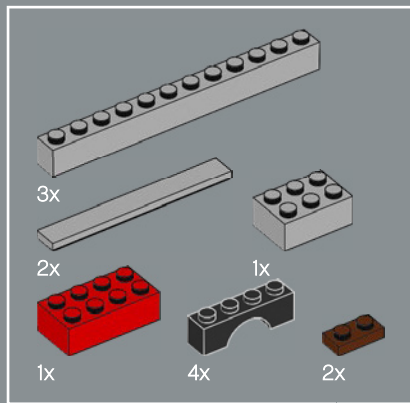

98

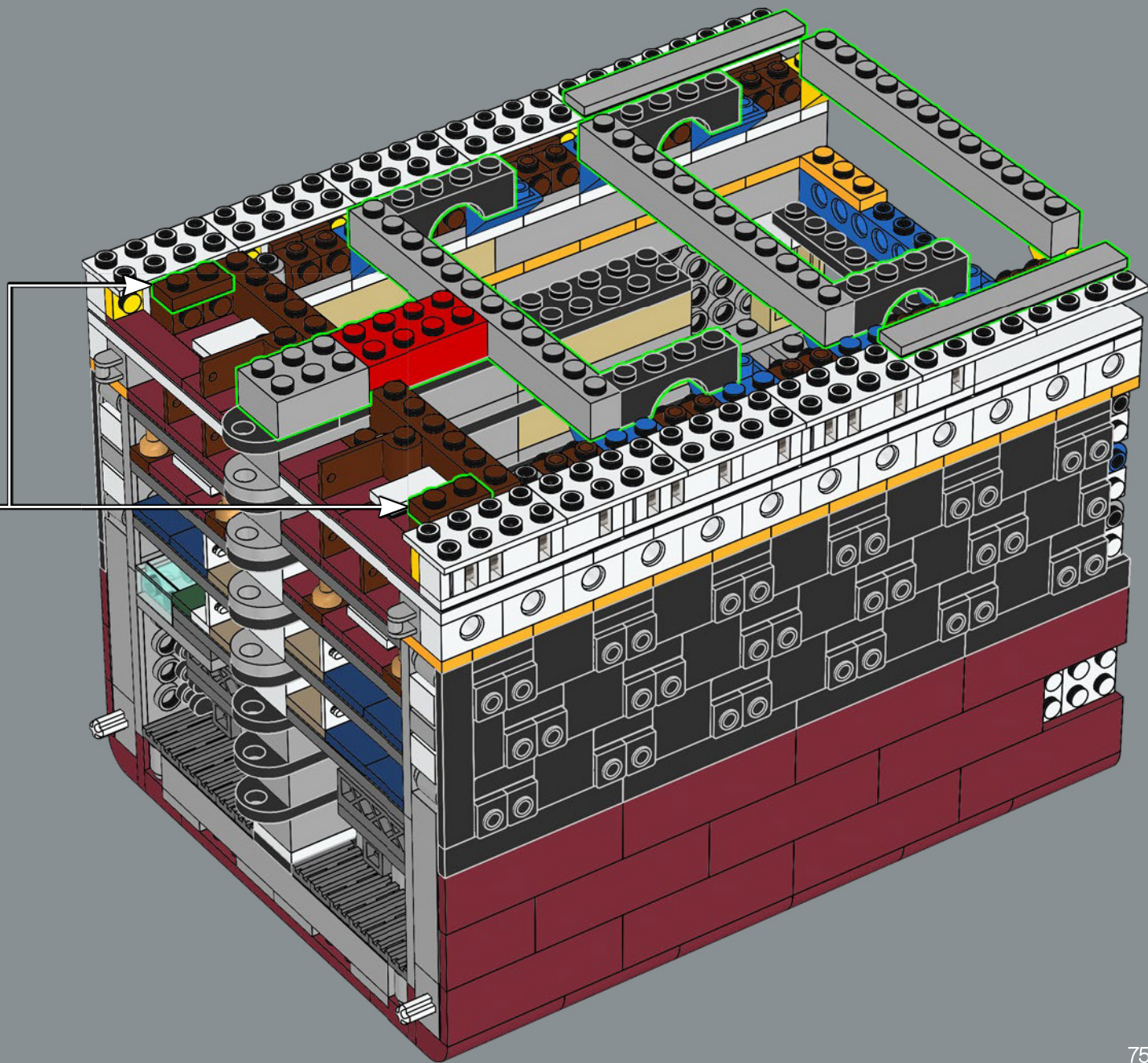

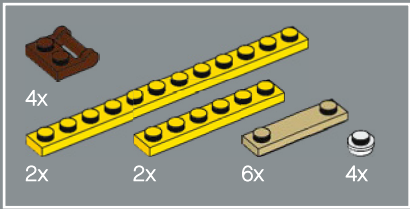

99

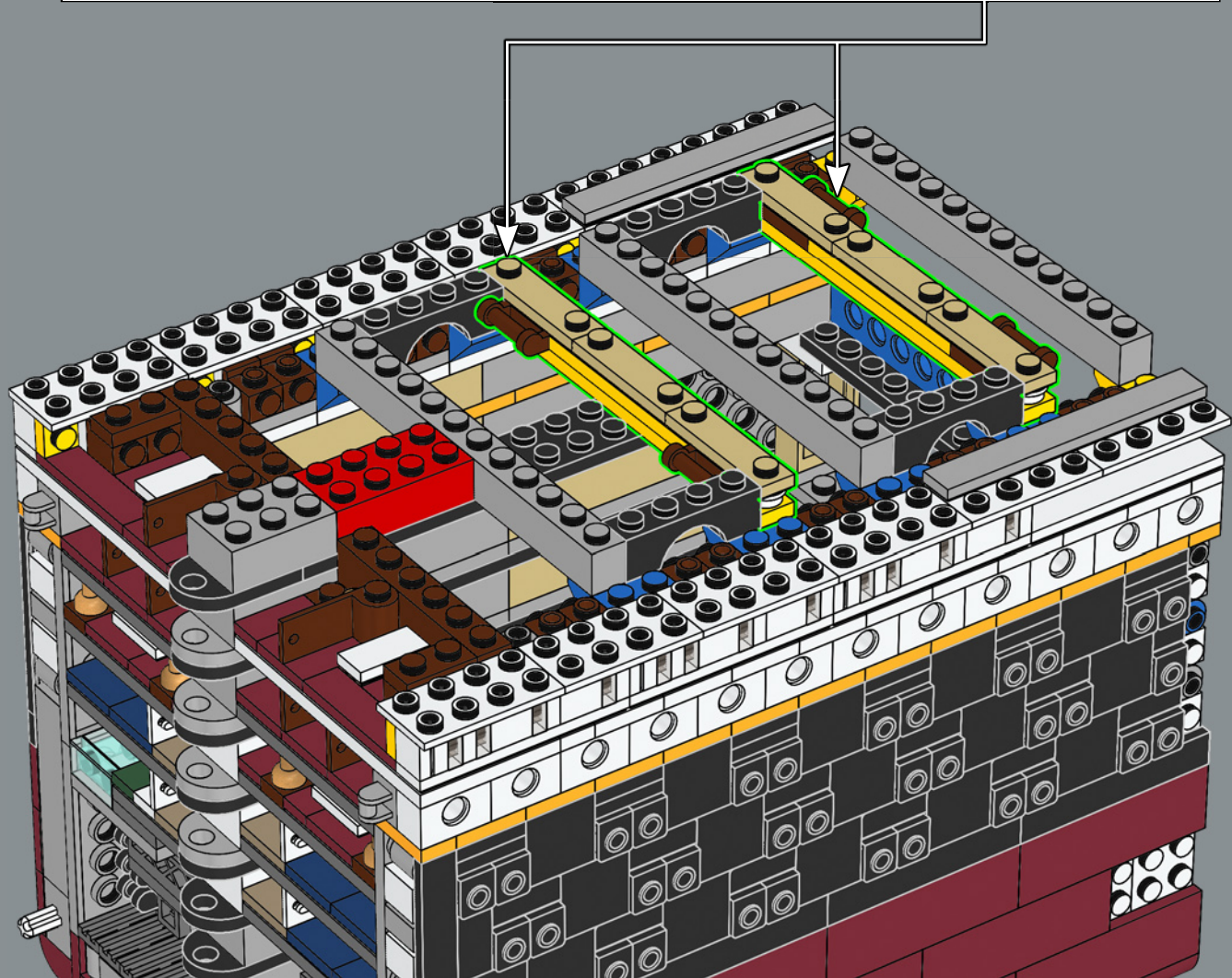
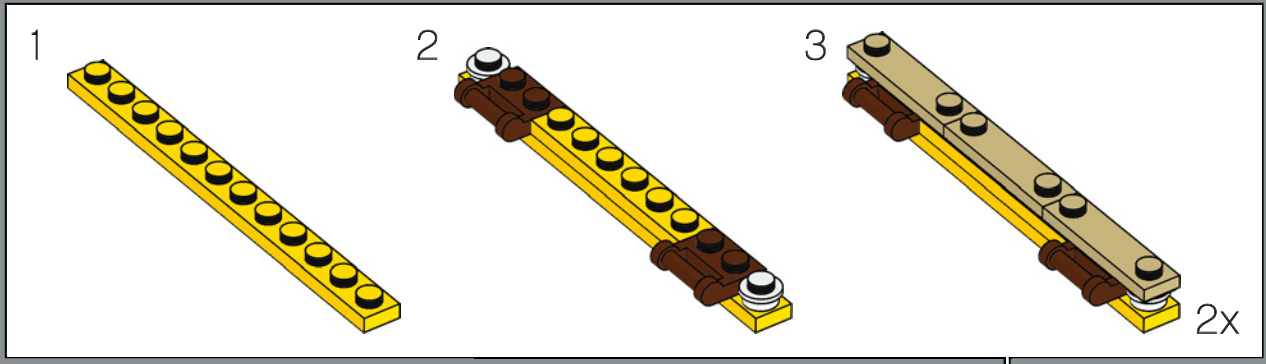

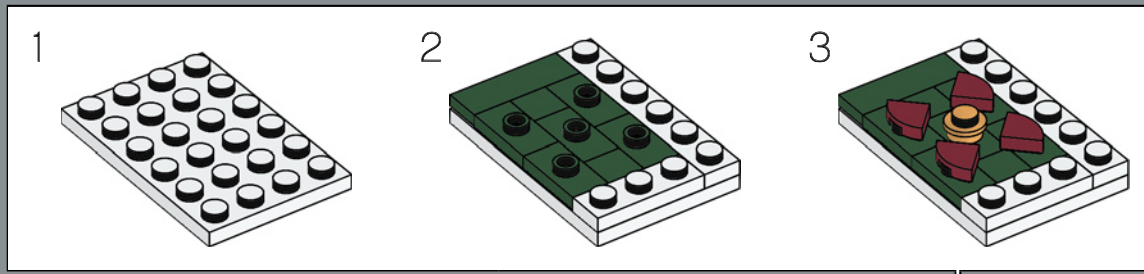
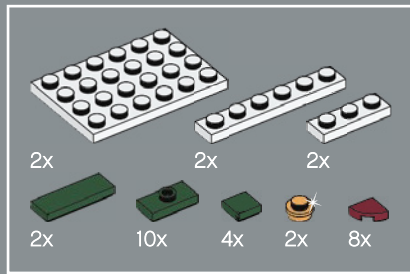

100

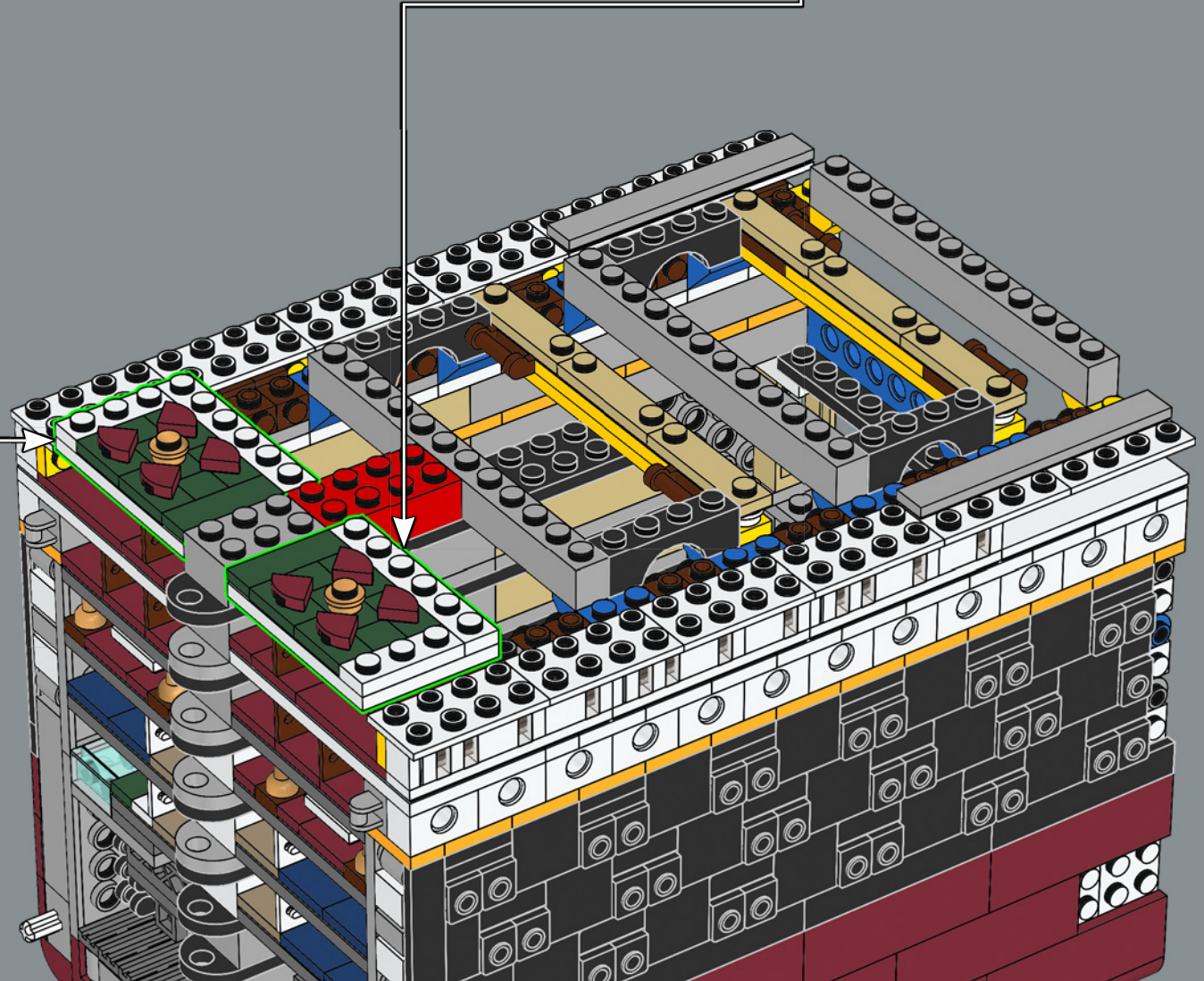
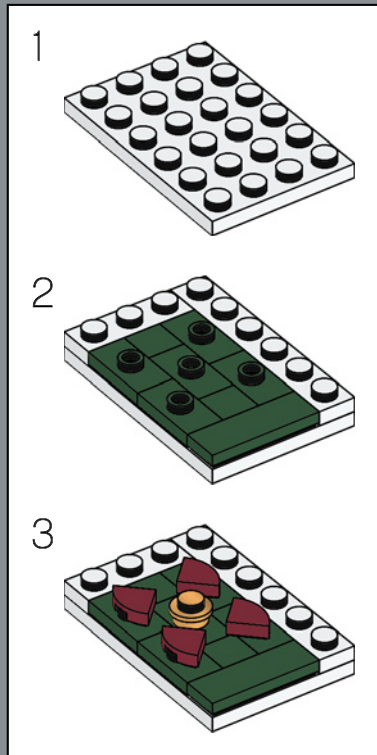

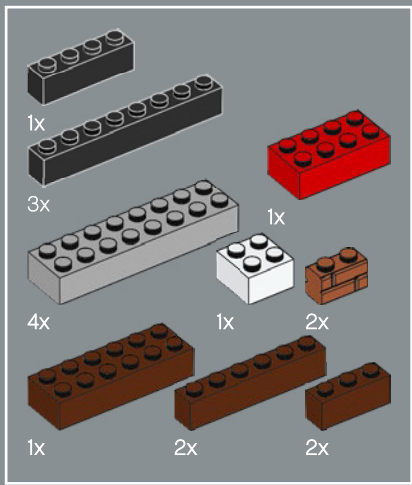

101

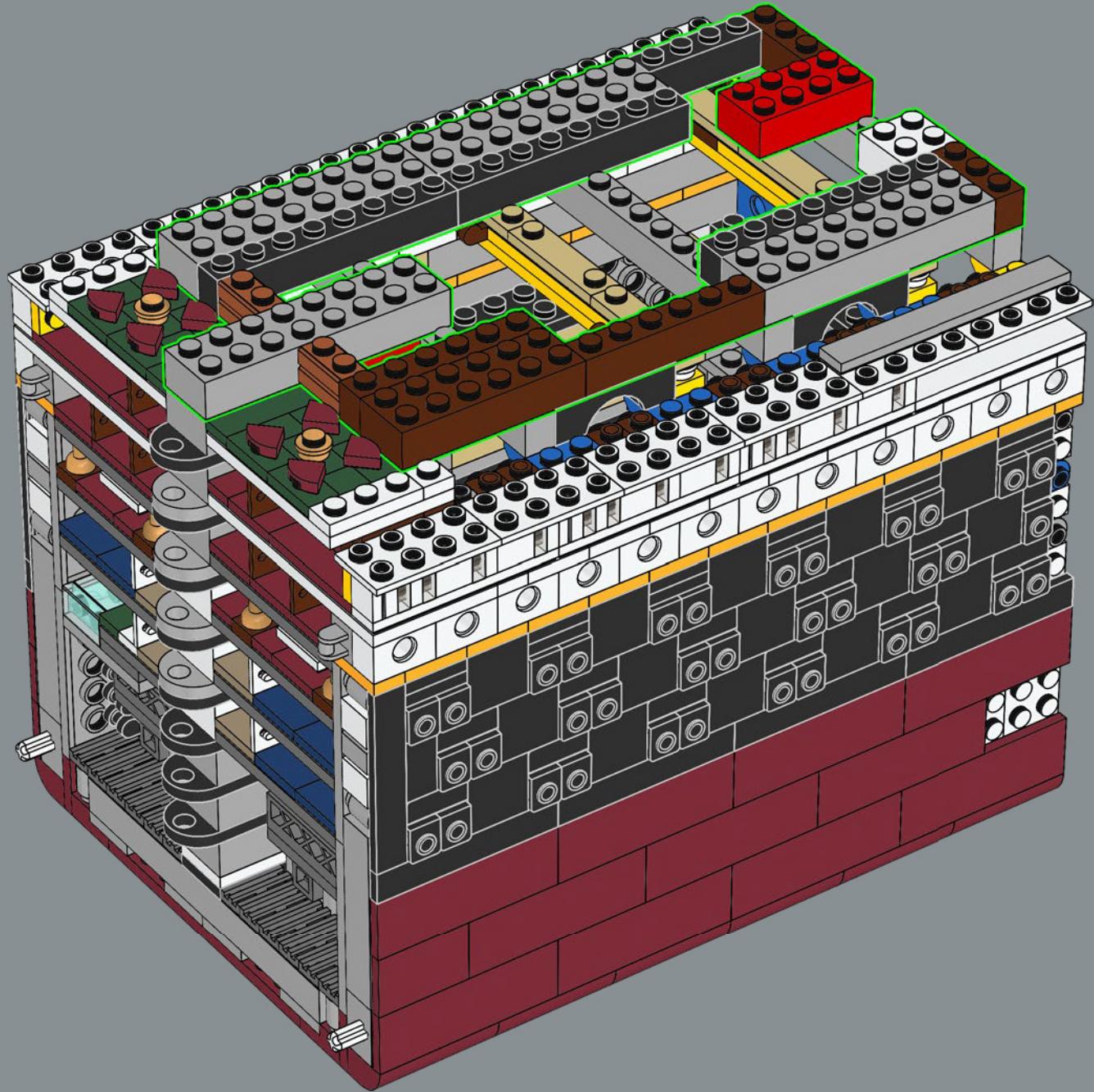

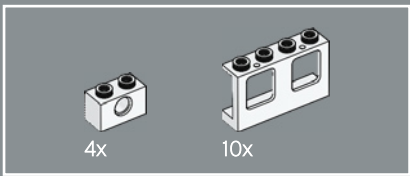

102

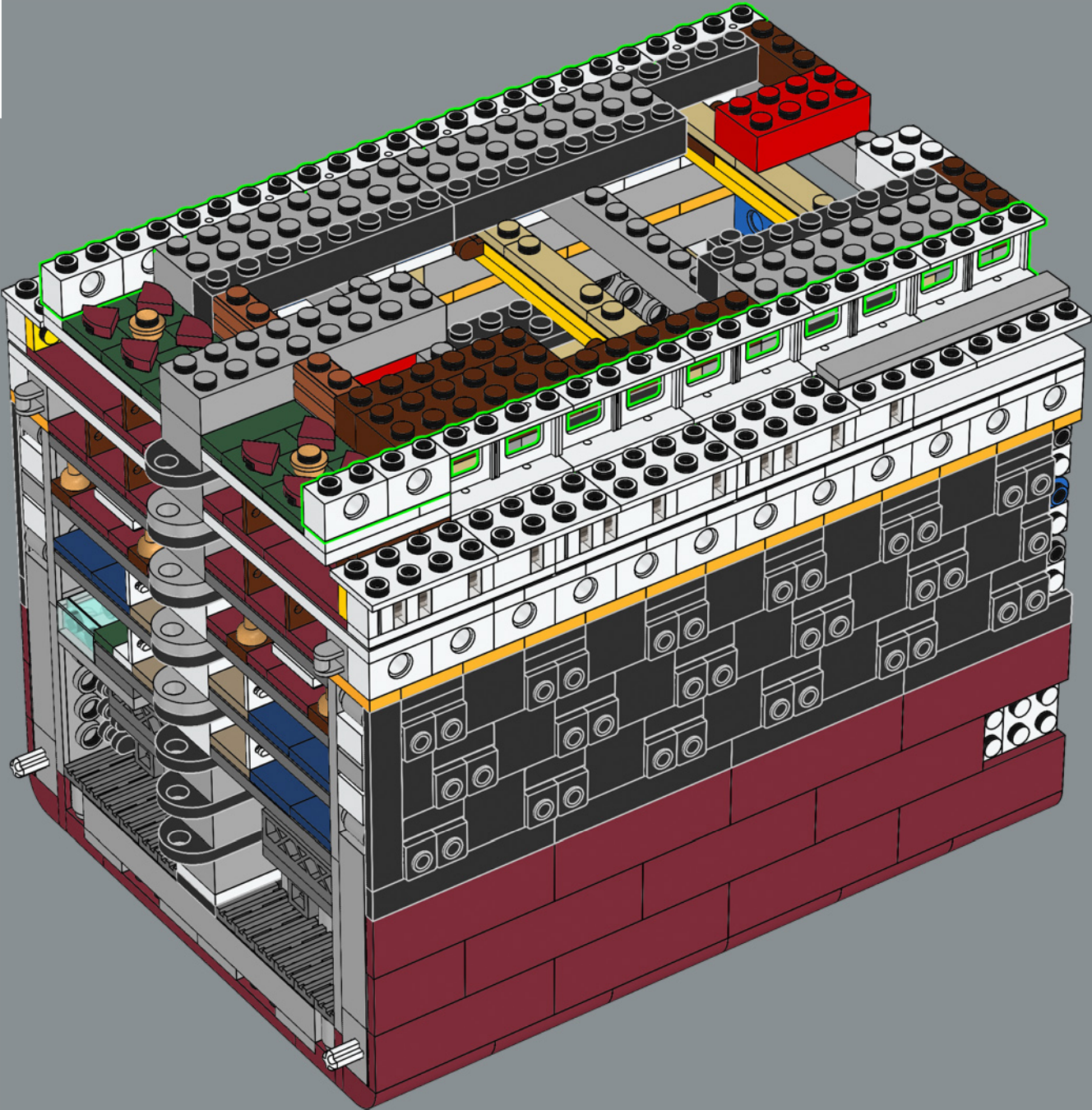

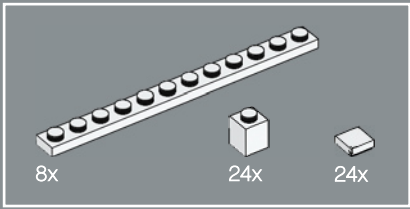

103

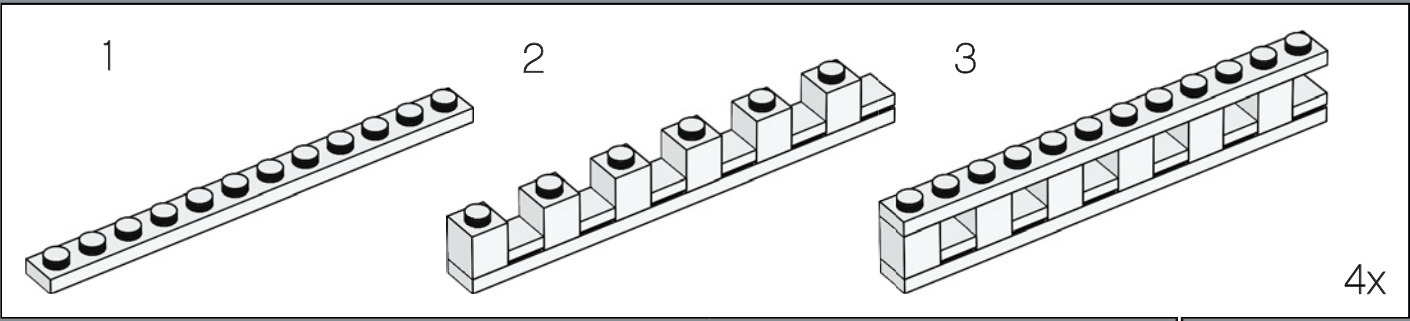

4x

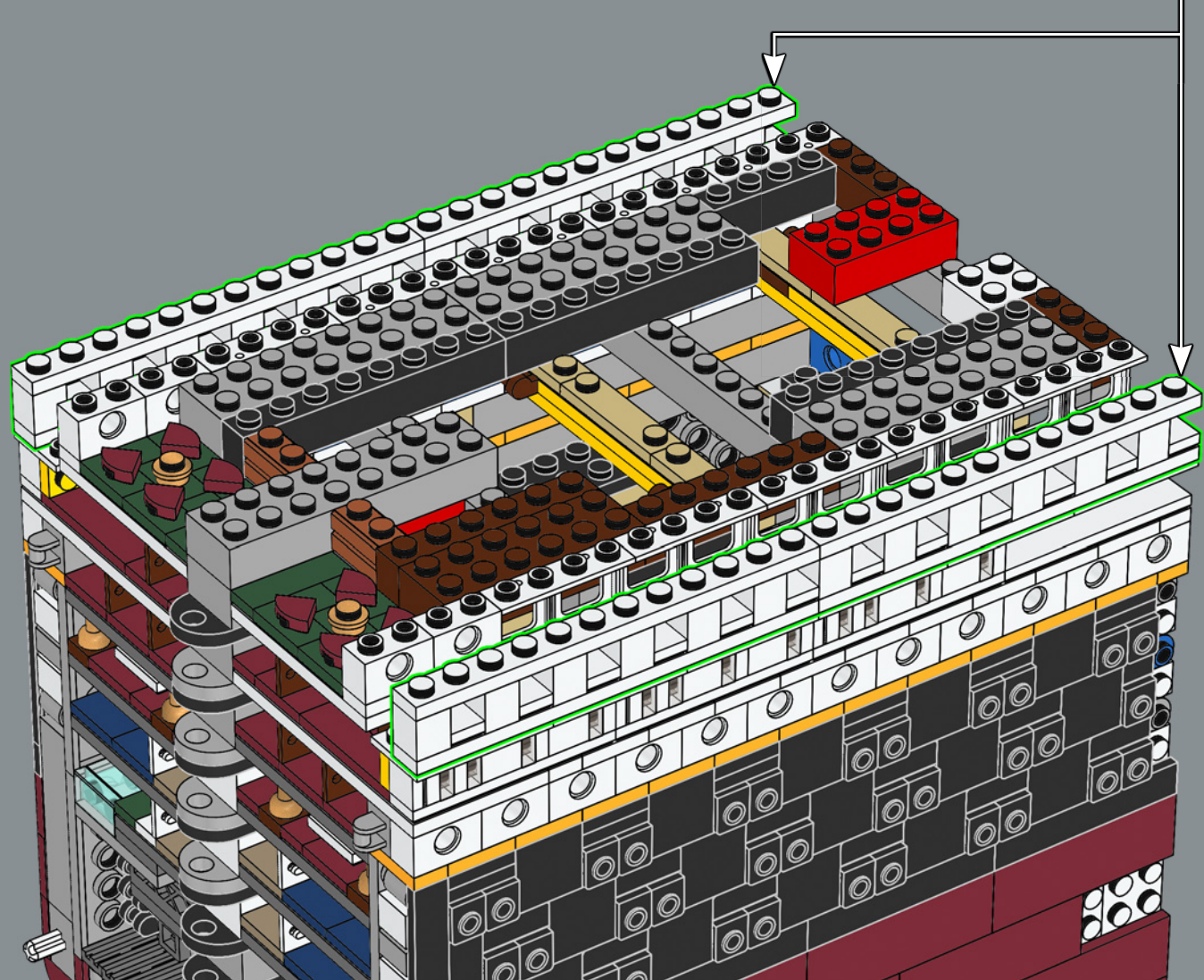

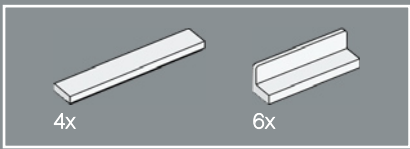

104

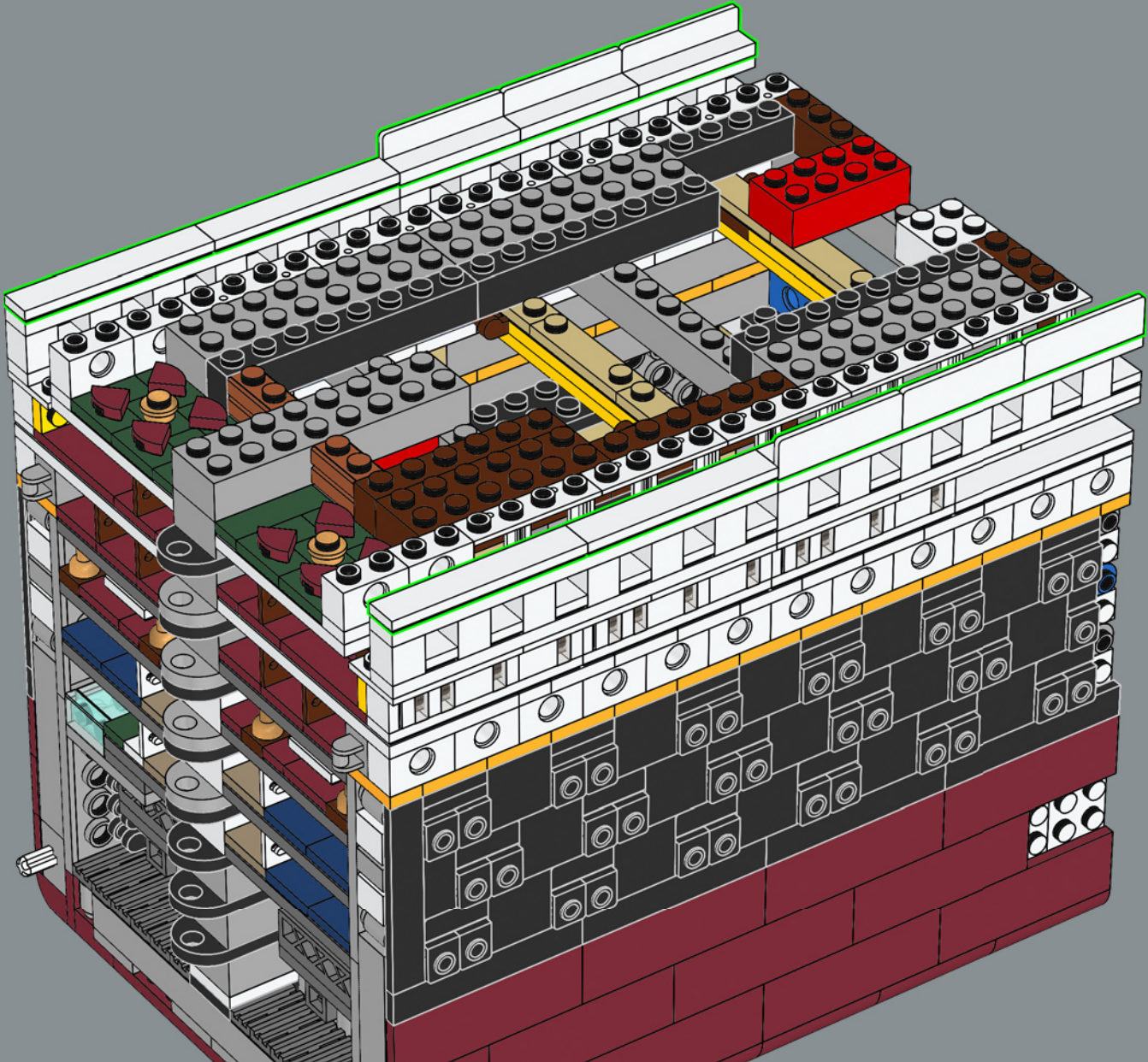

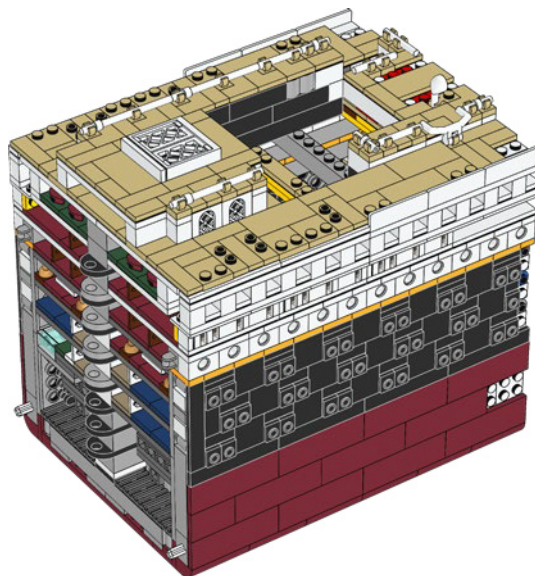
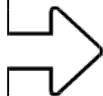

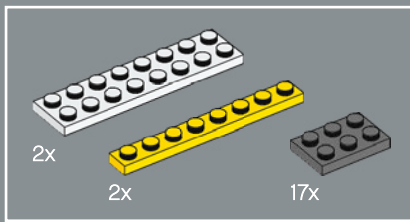

105

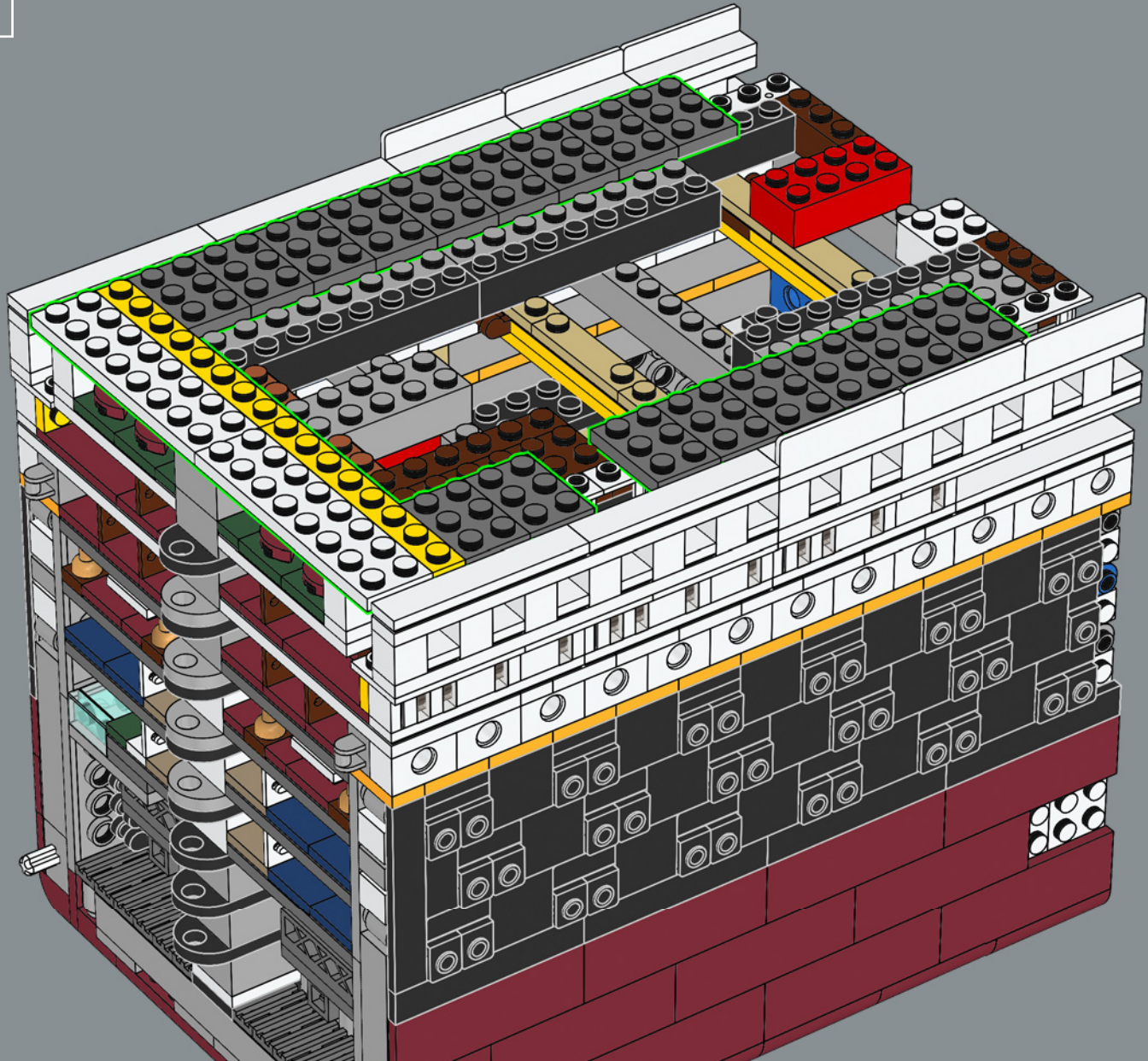

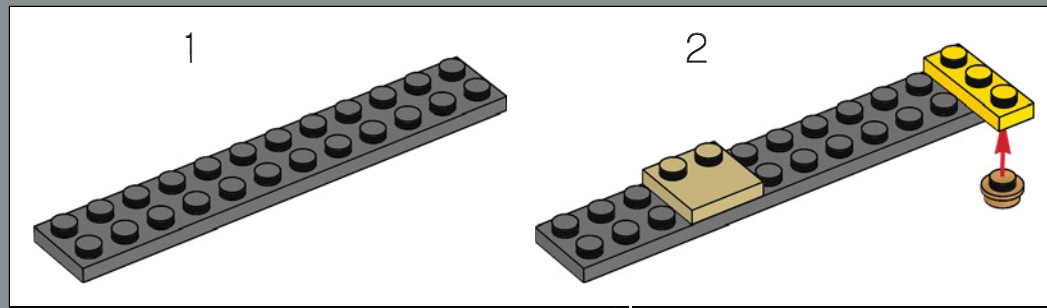
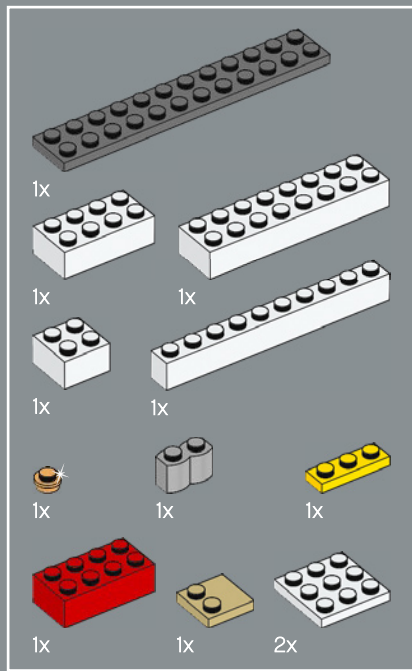

106

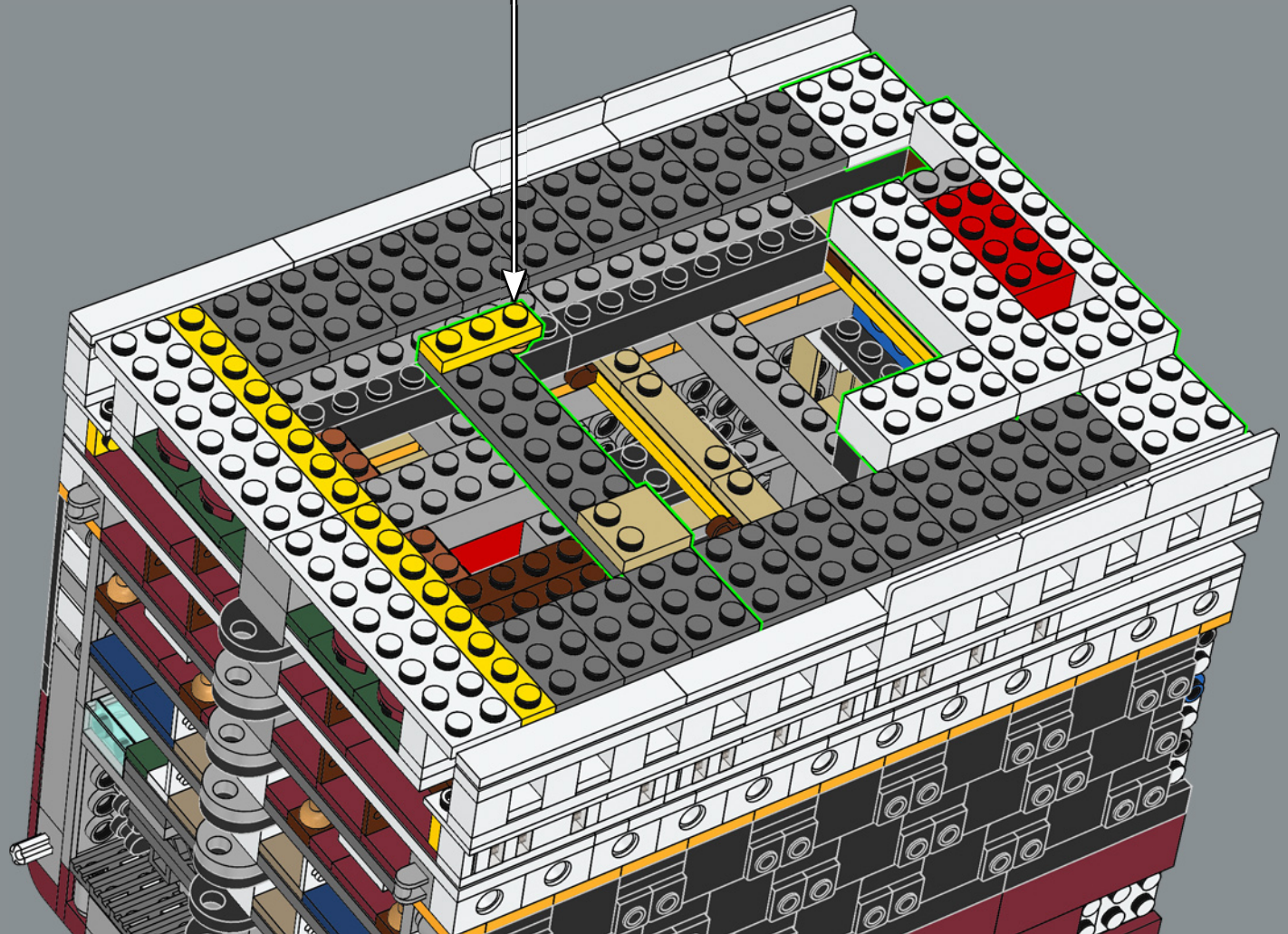

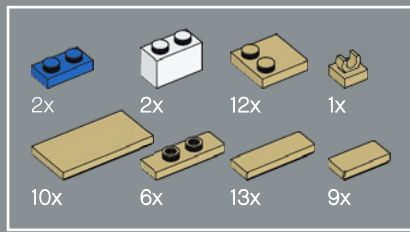

107

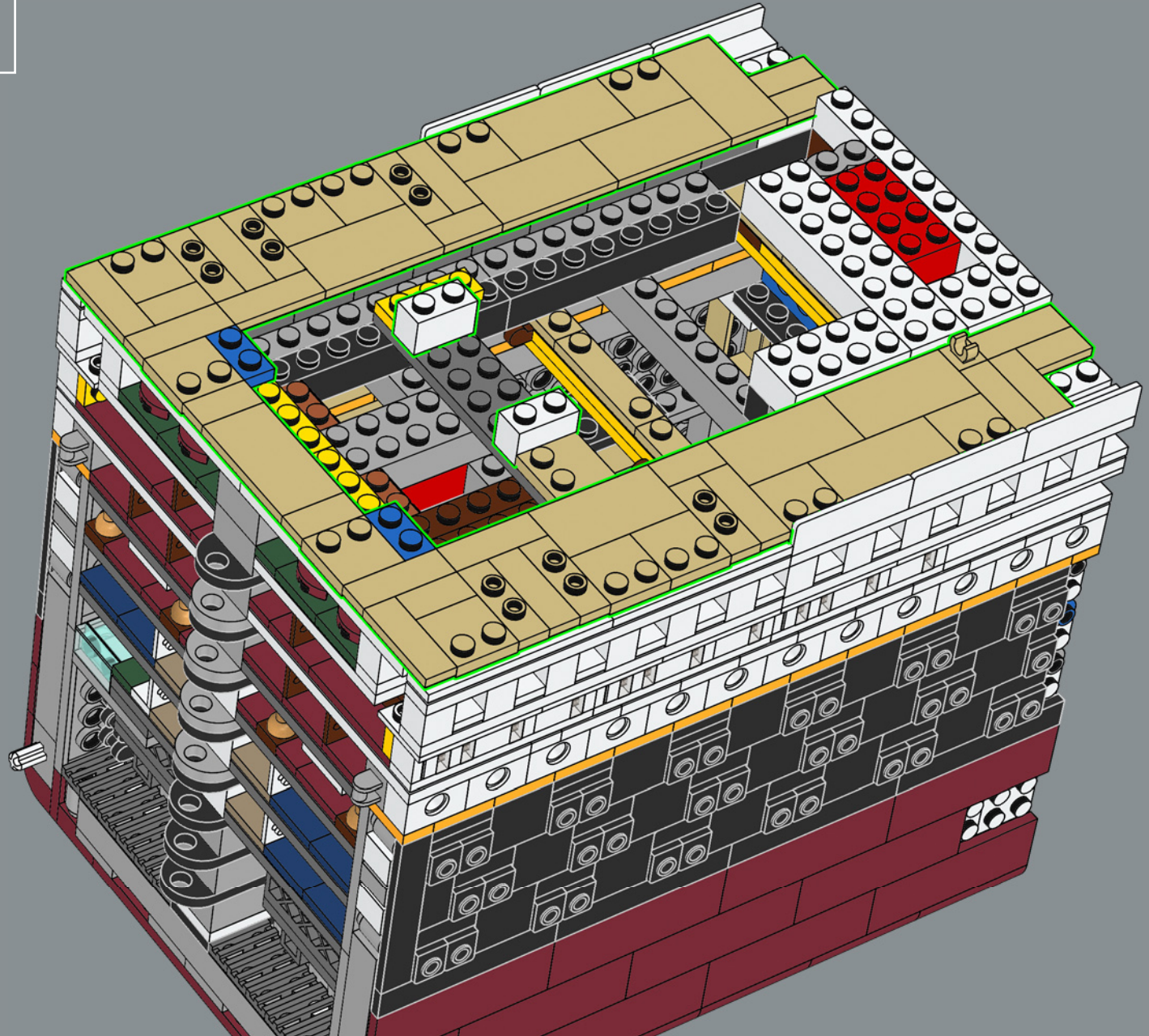

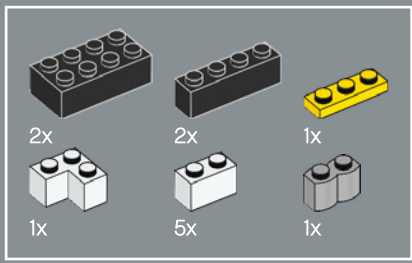

108

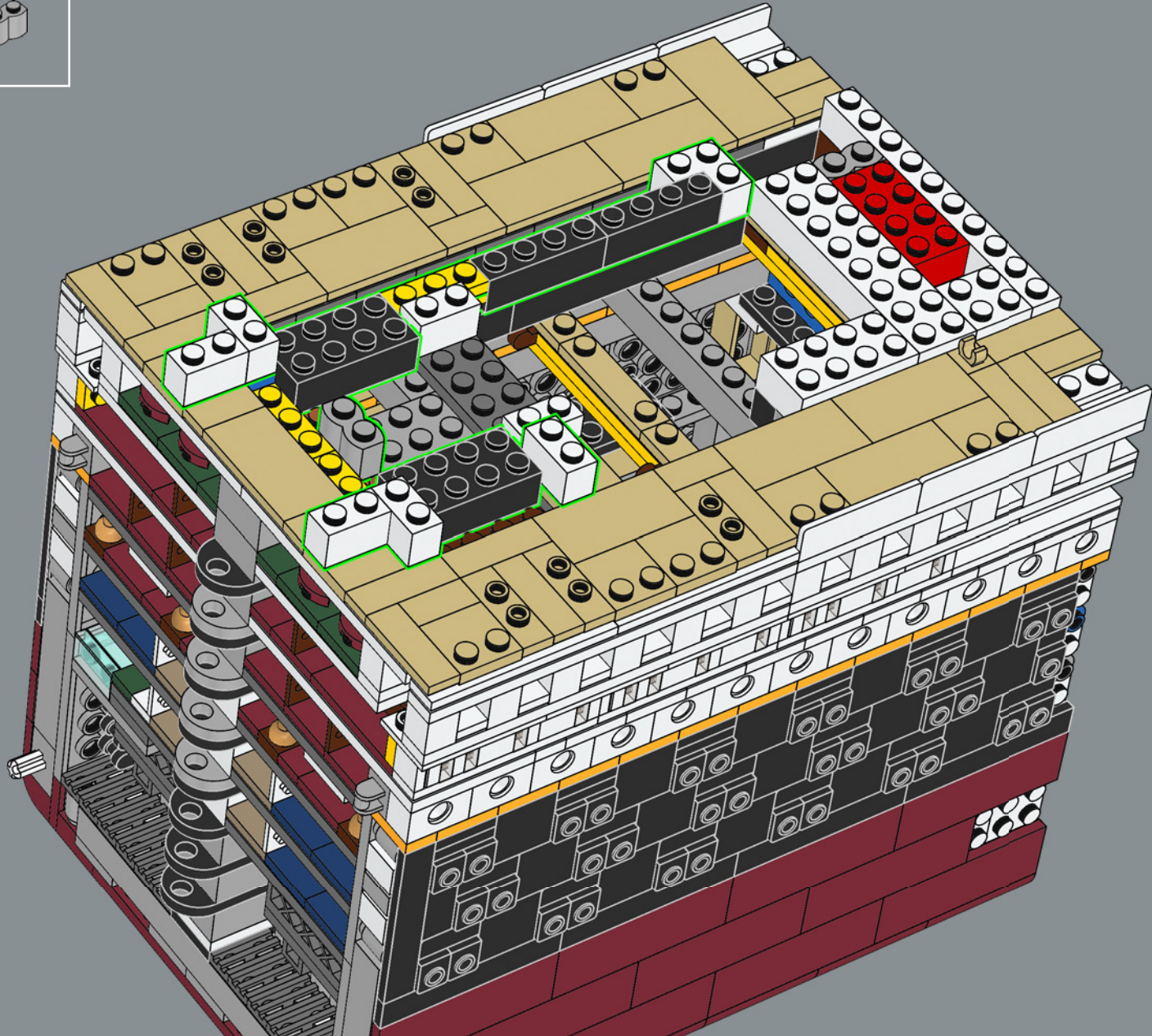

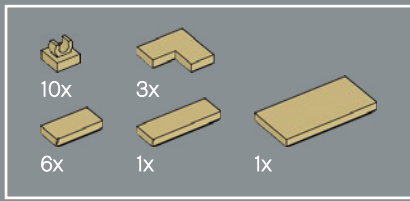

109

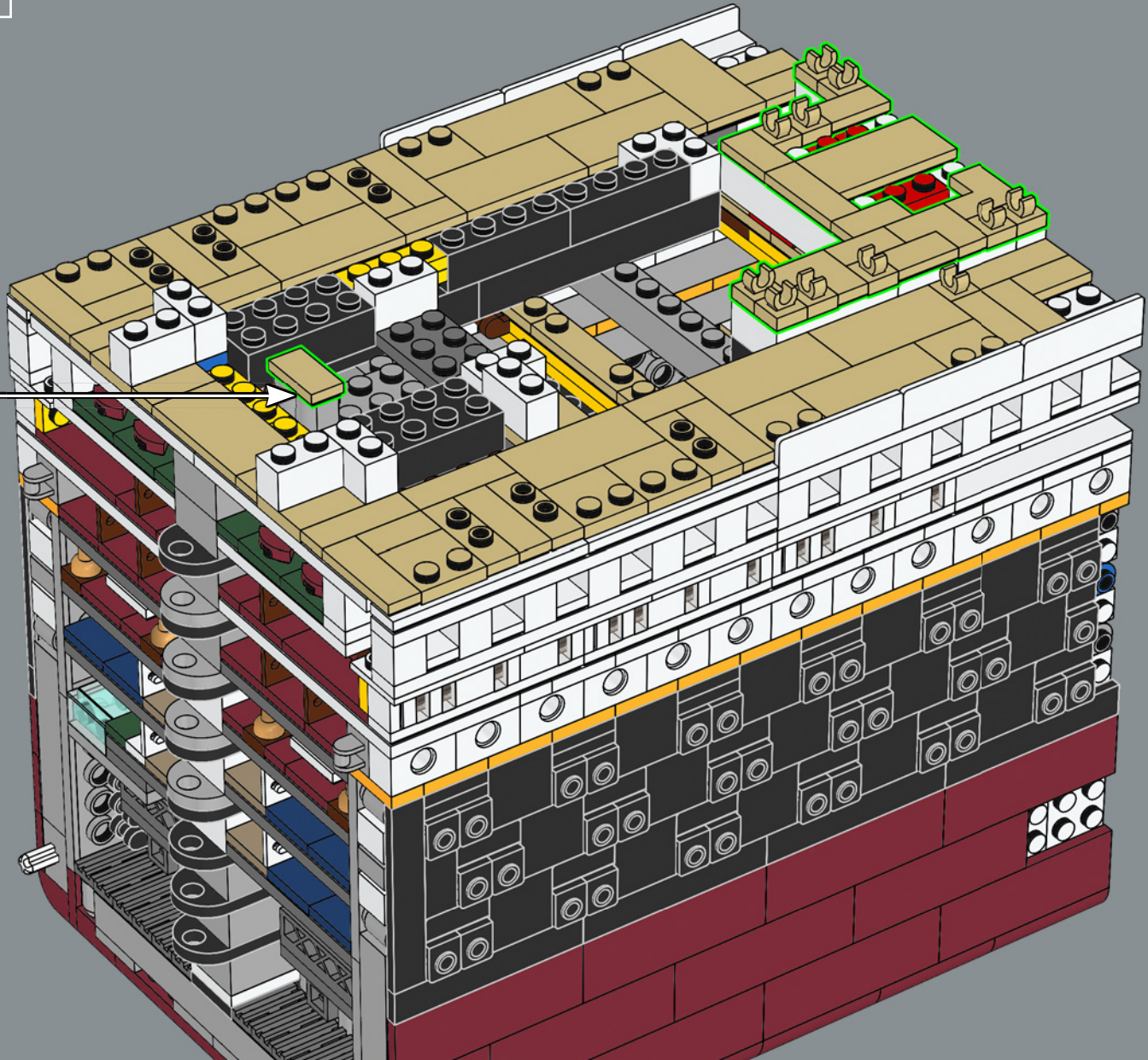

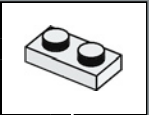
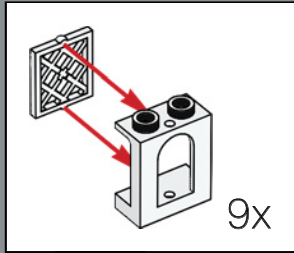
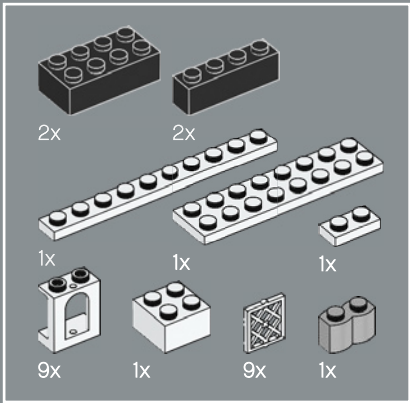

110

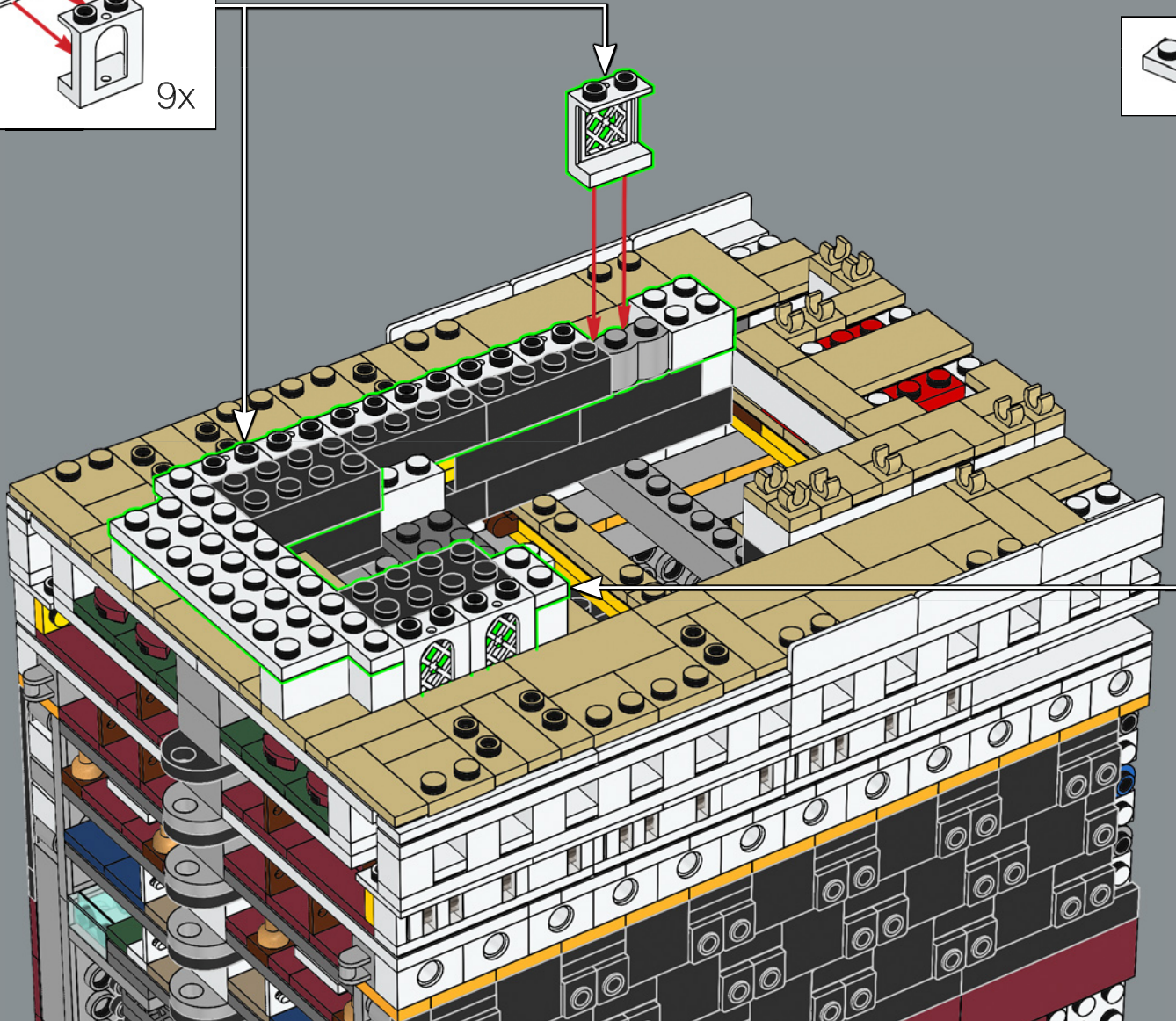

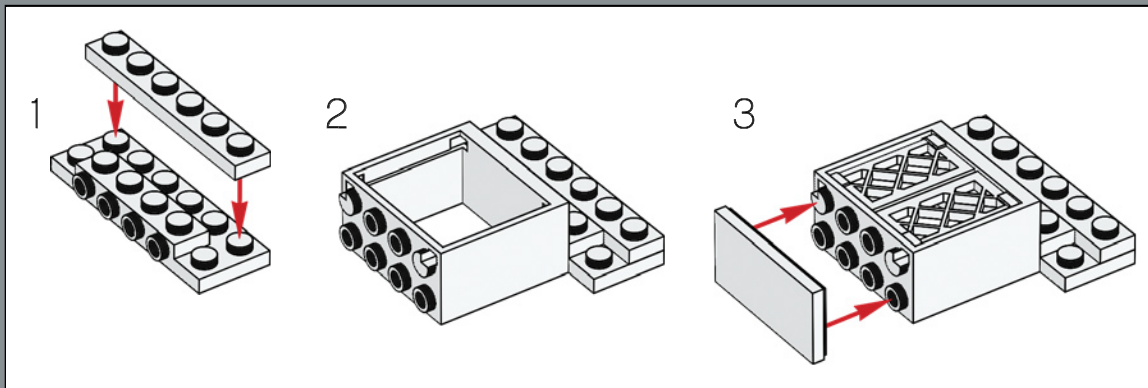
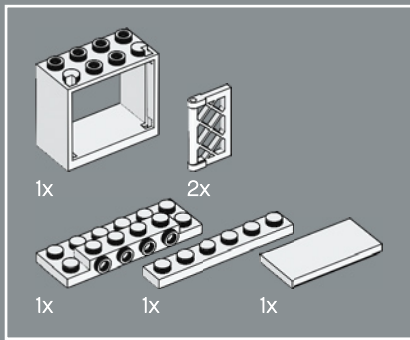

111

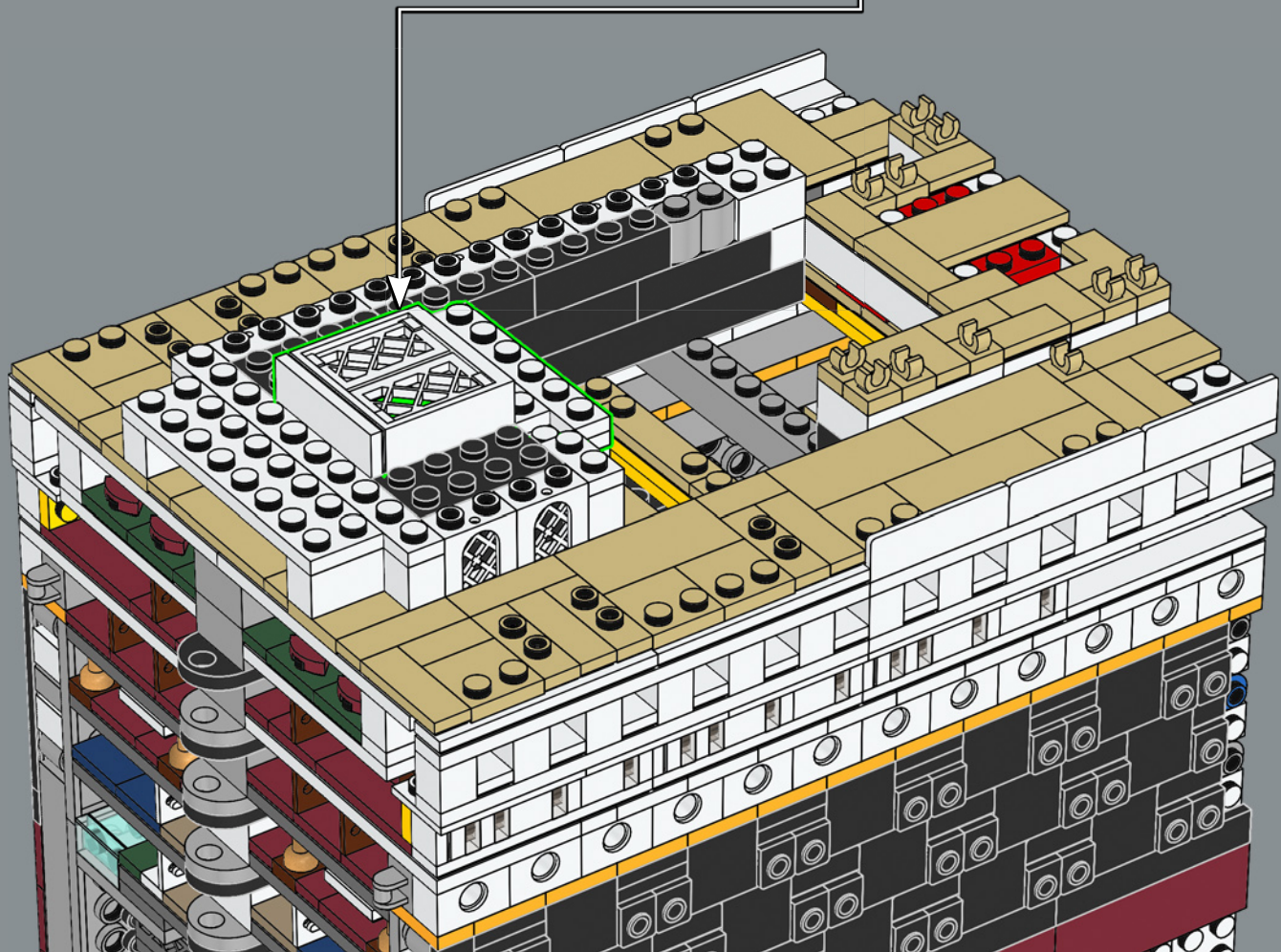

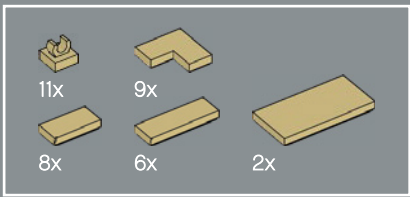

112

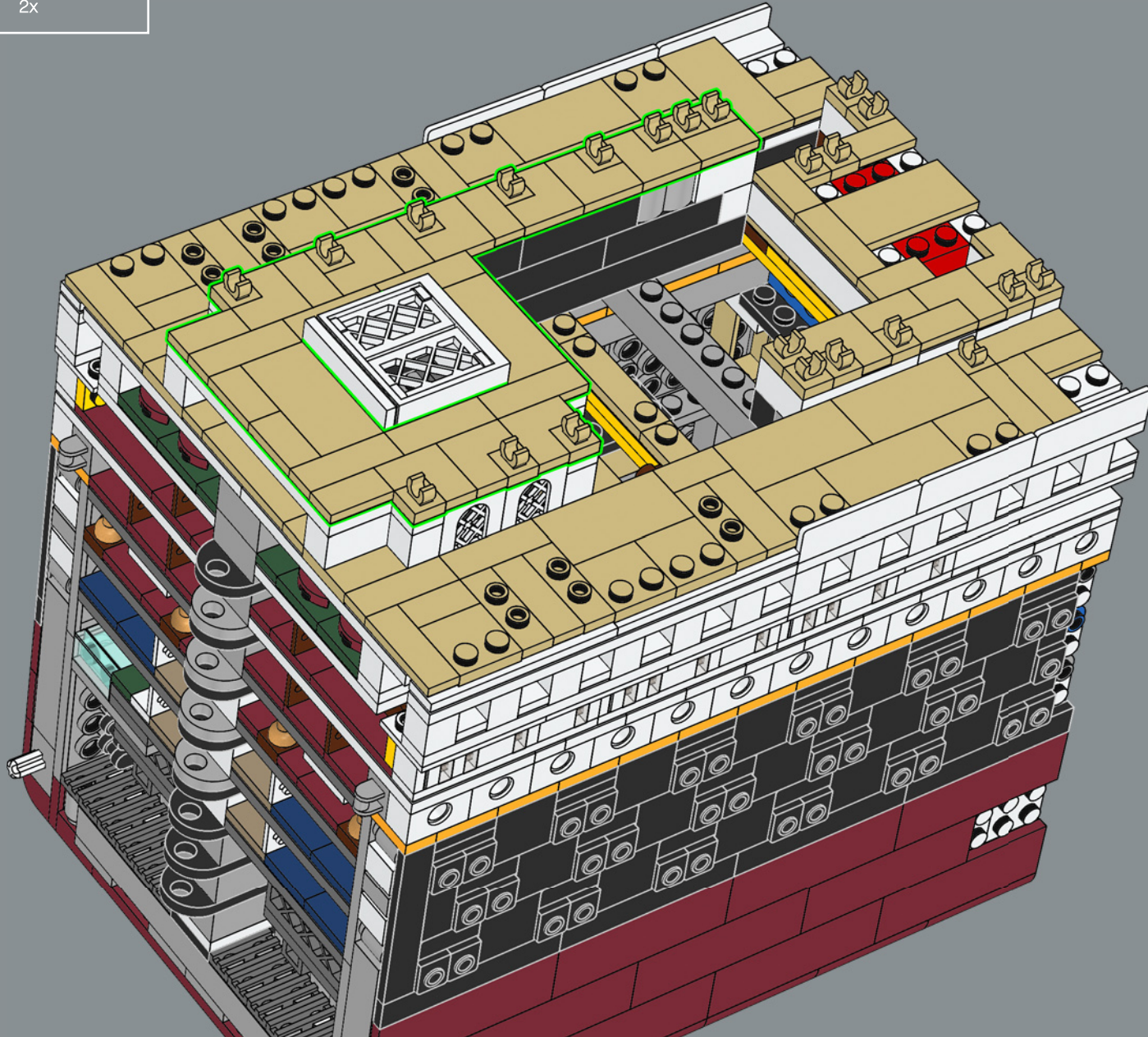

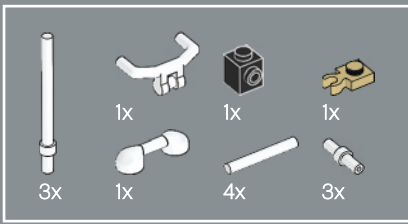

113

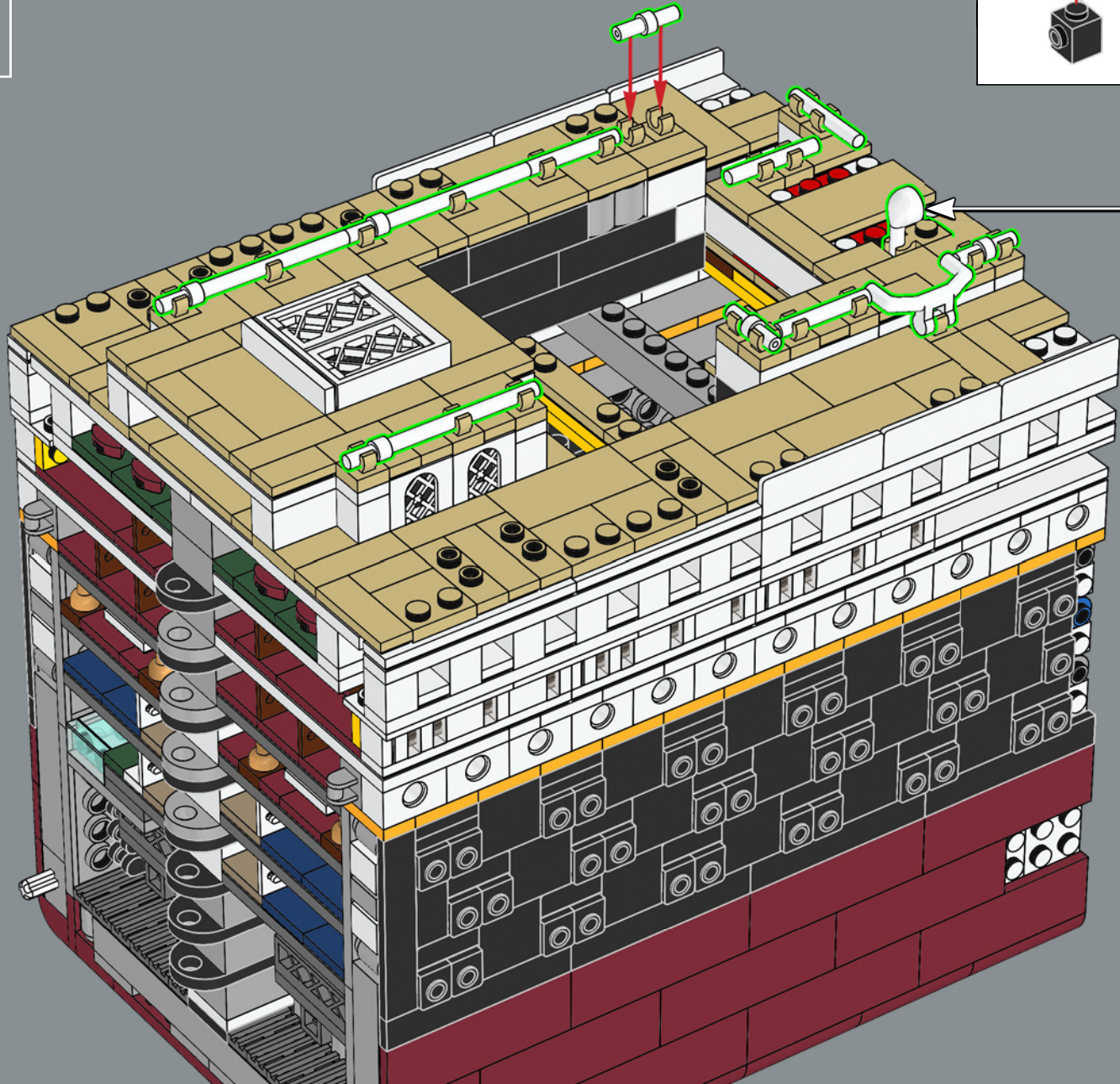
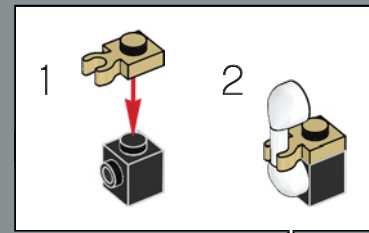

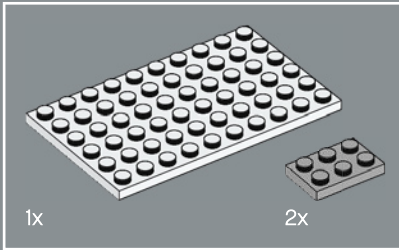
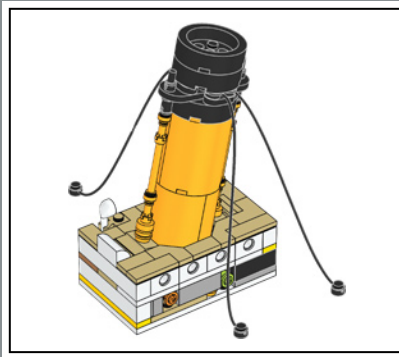
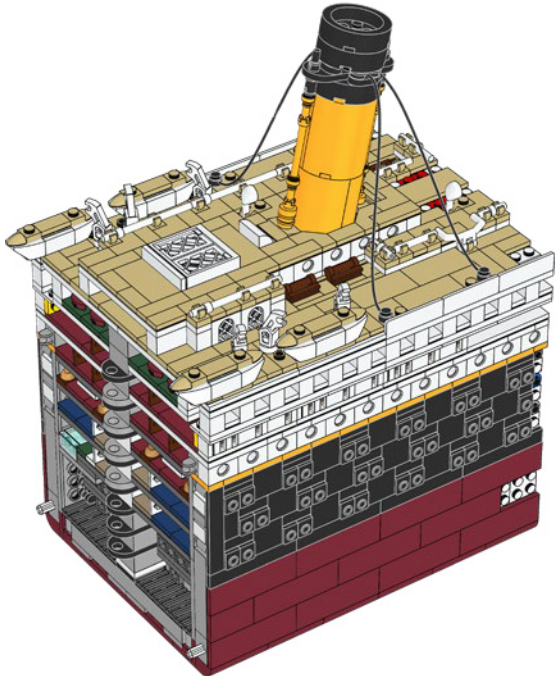
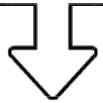

114

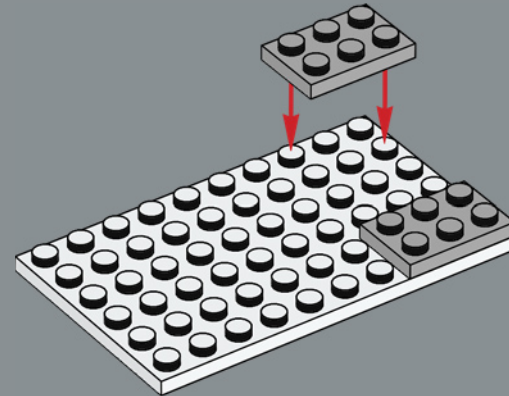

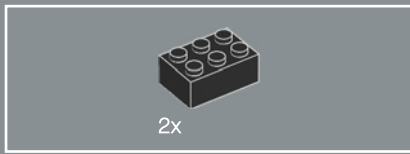

115

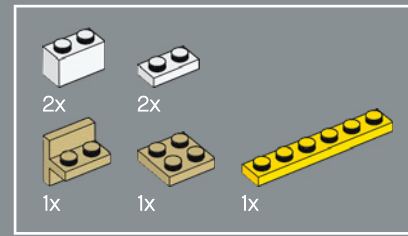
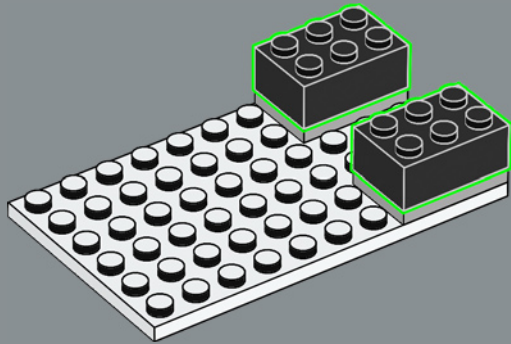

116

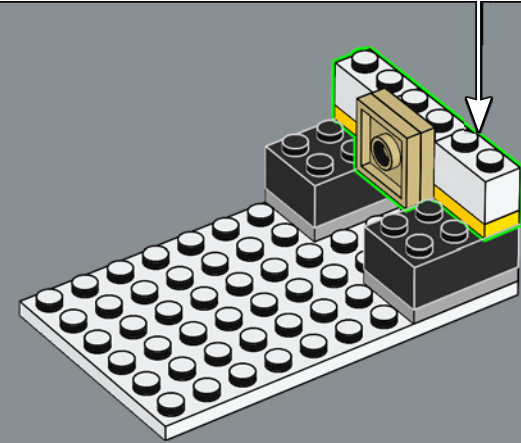
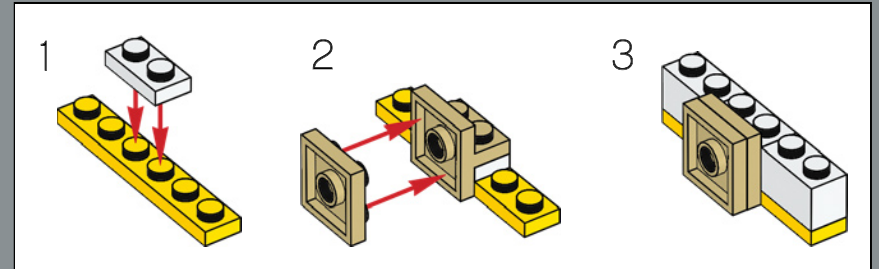

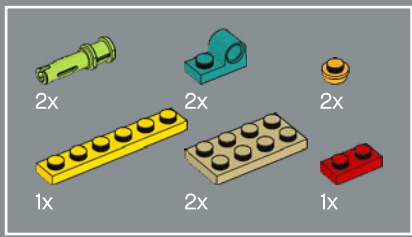

117

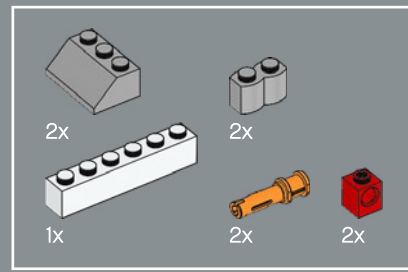
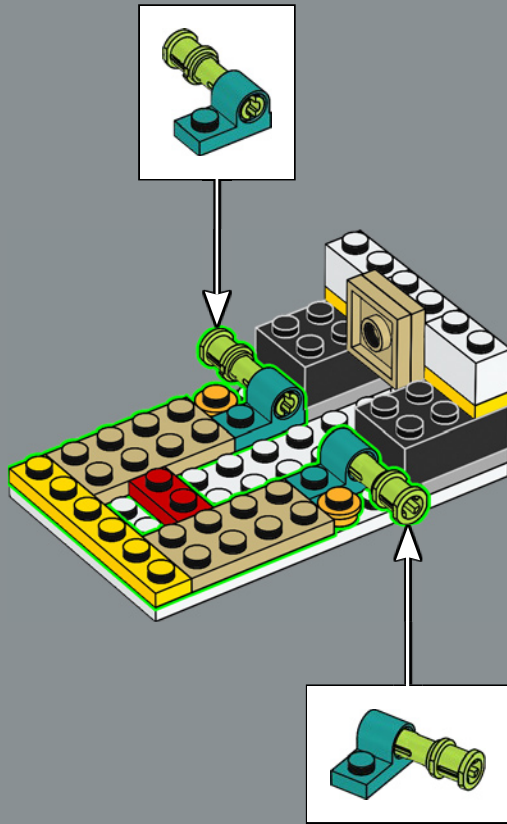

118

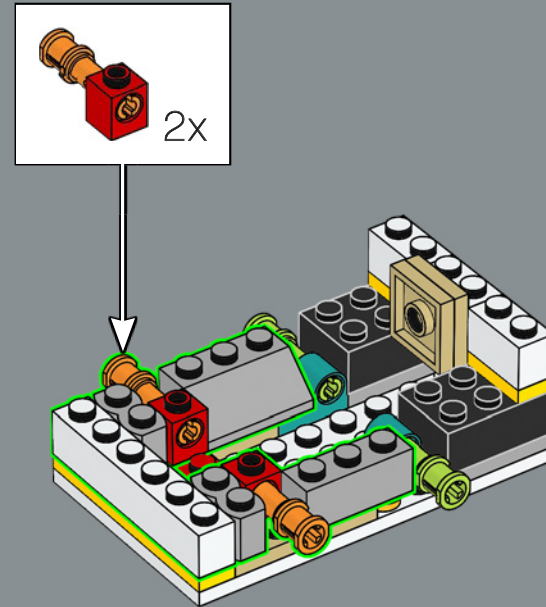

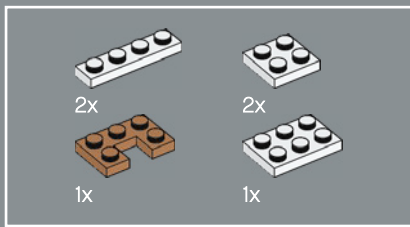

119

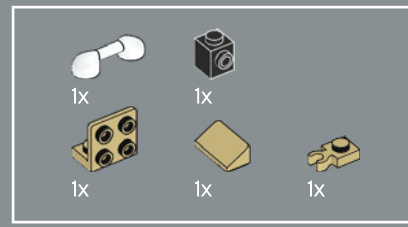
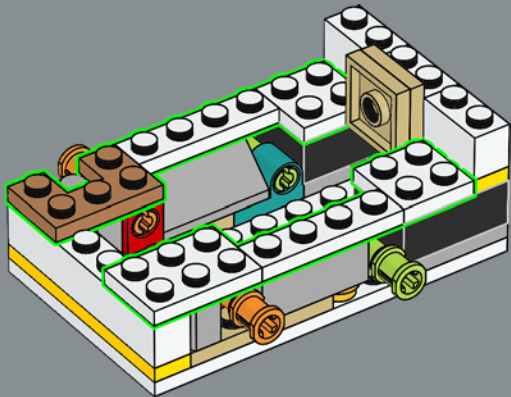

120

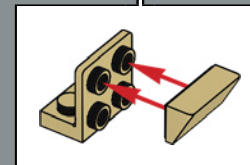
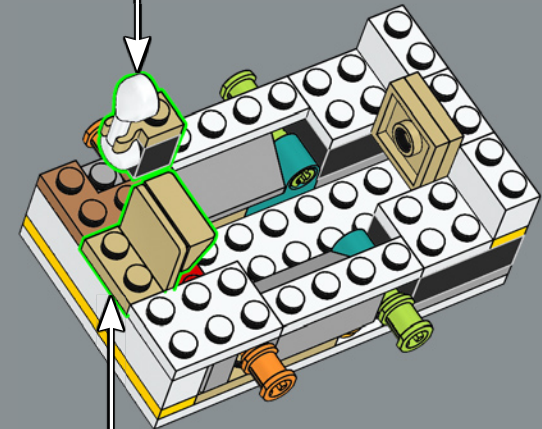
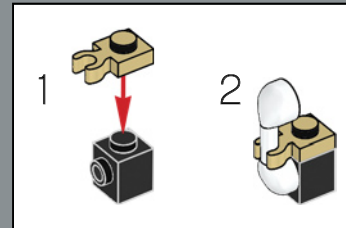

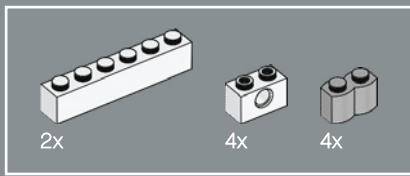

121

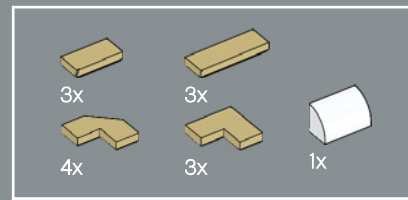
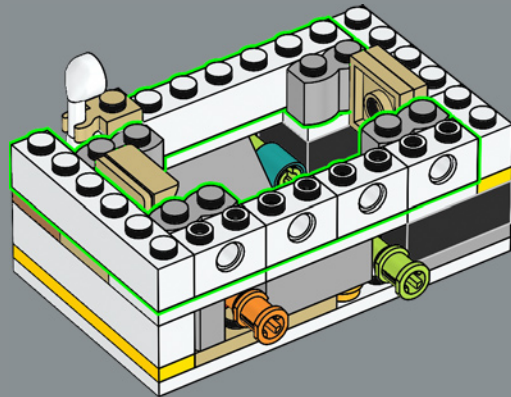

122

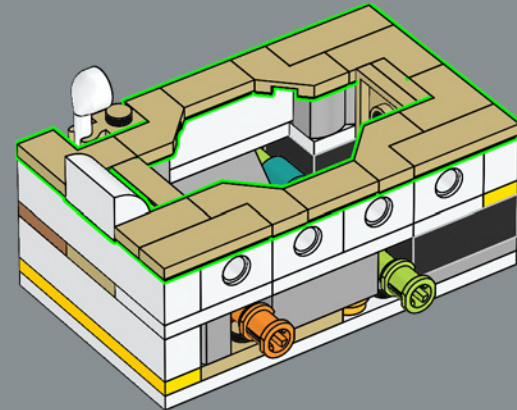

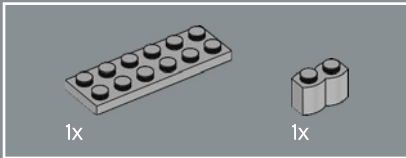
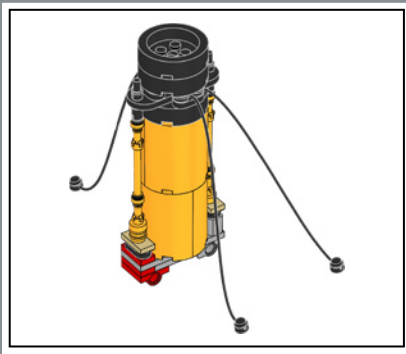

123

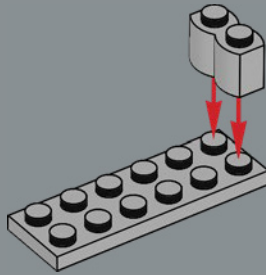

124

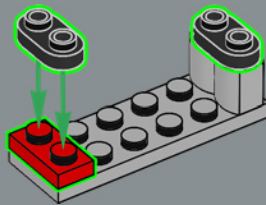

125

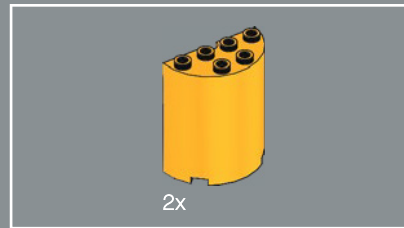
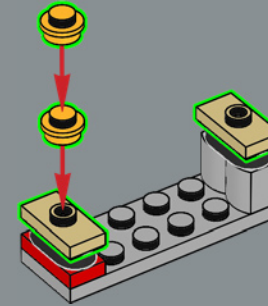

126

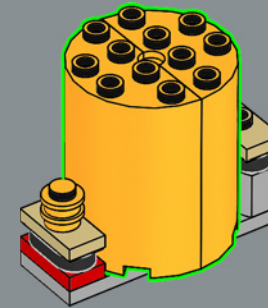

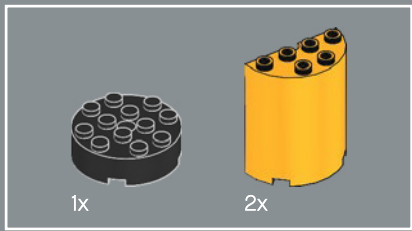

127

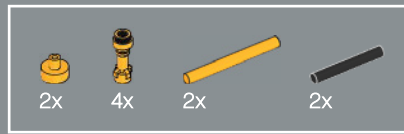
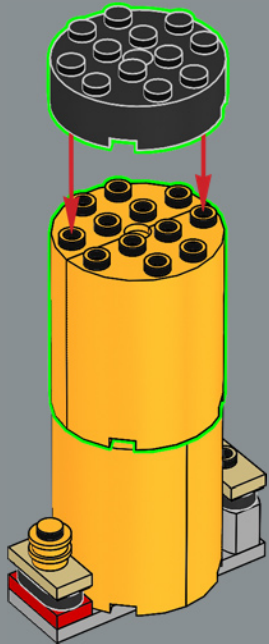

128

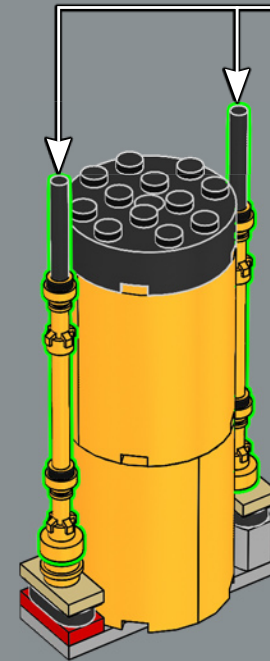
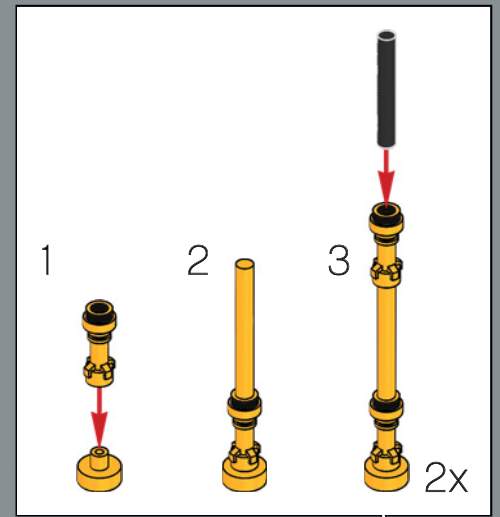

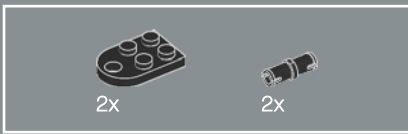

129

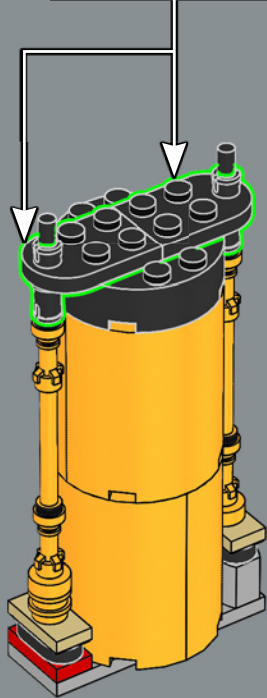
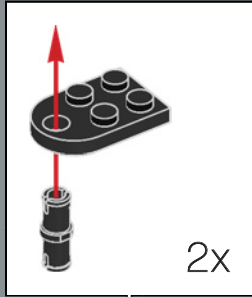

130

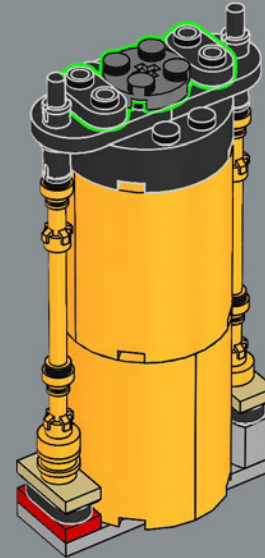

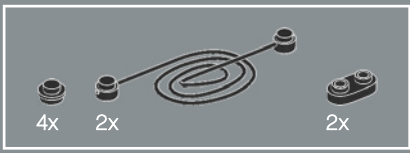

131

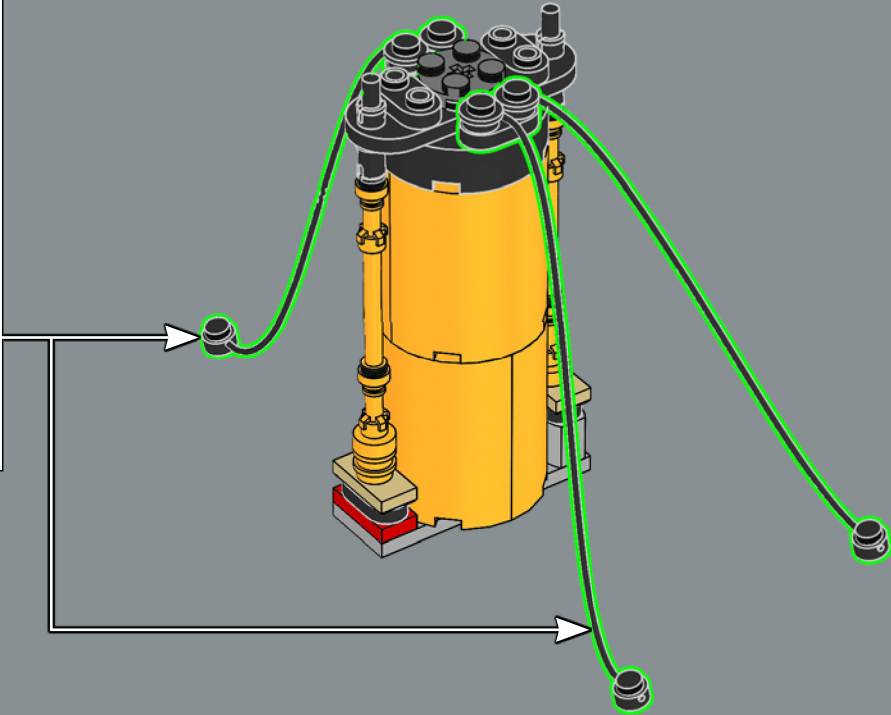
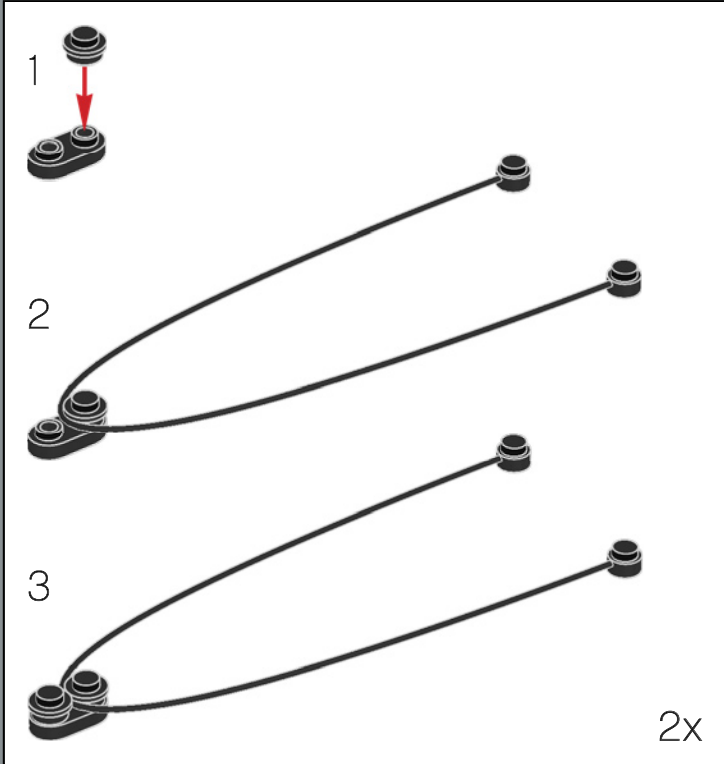

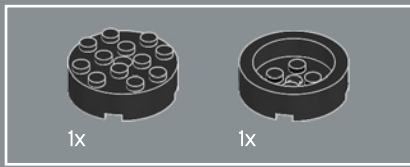

132

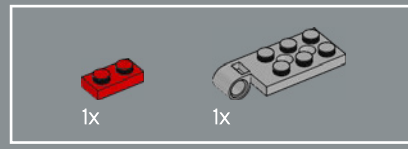
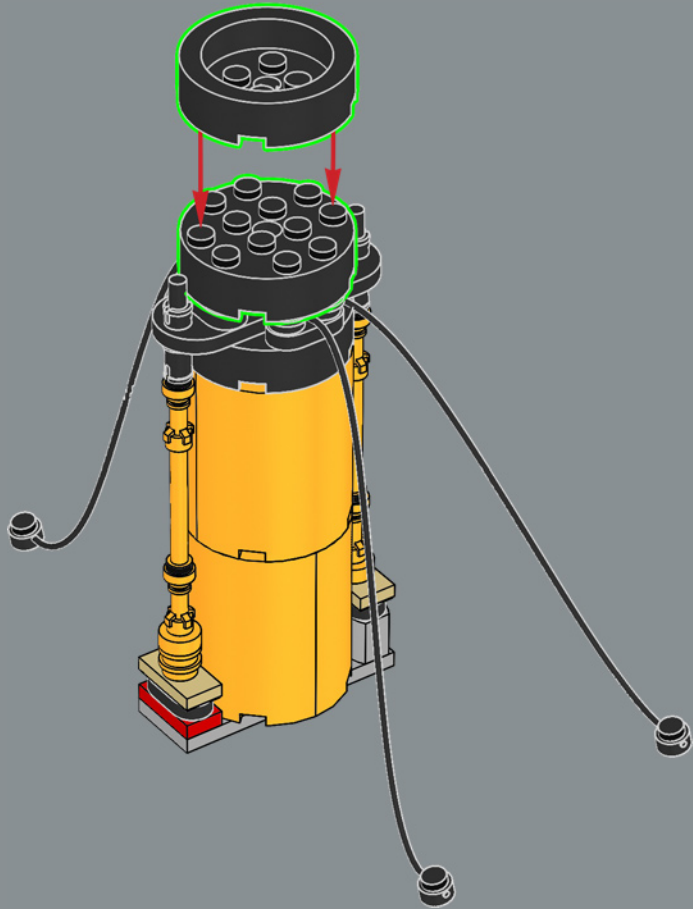

133

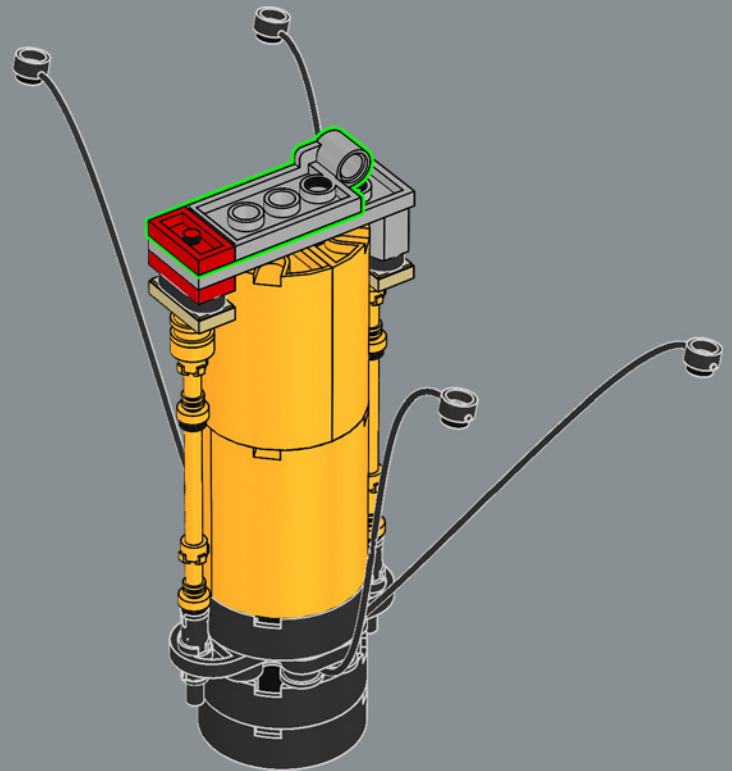

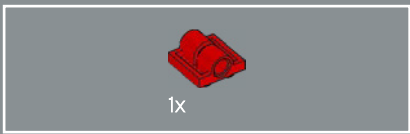

134

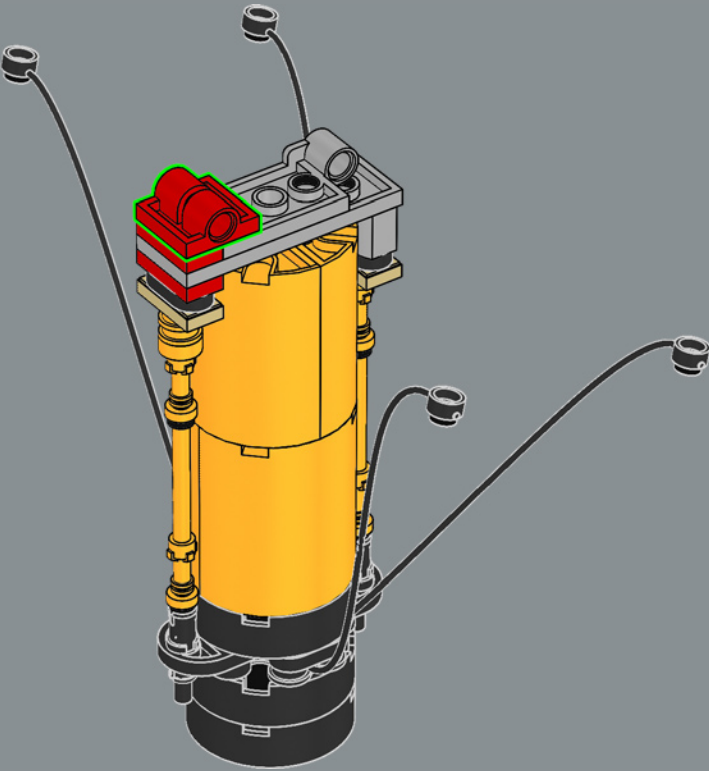

135

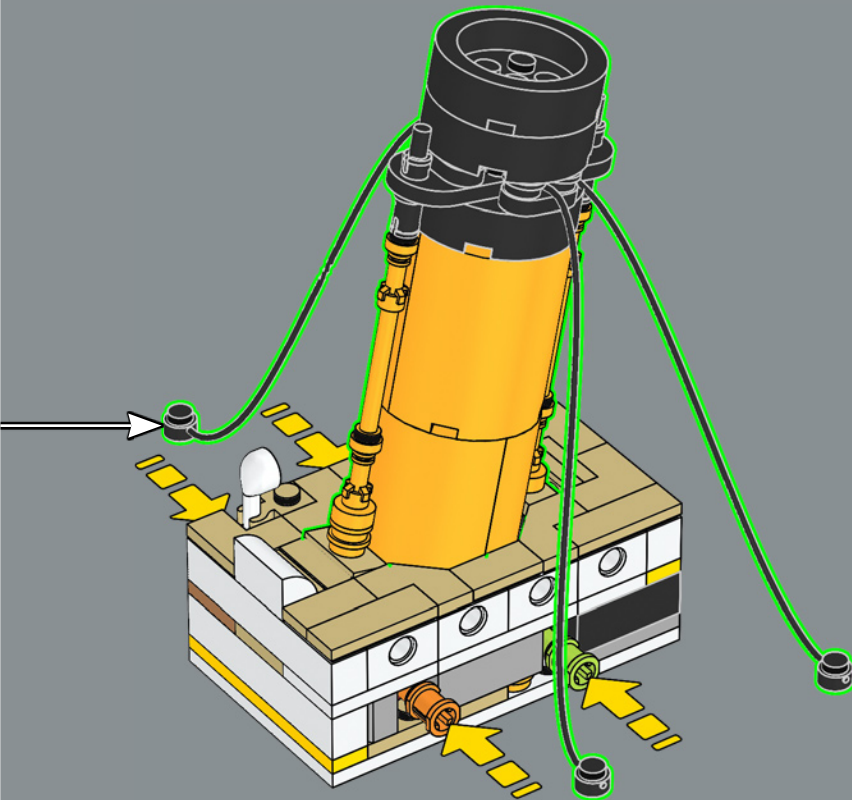

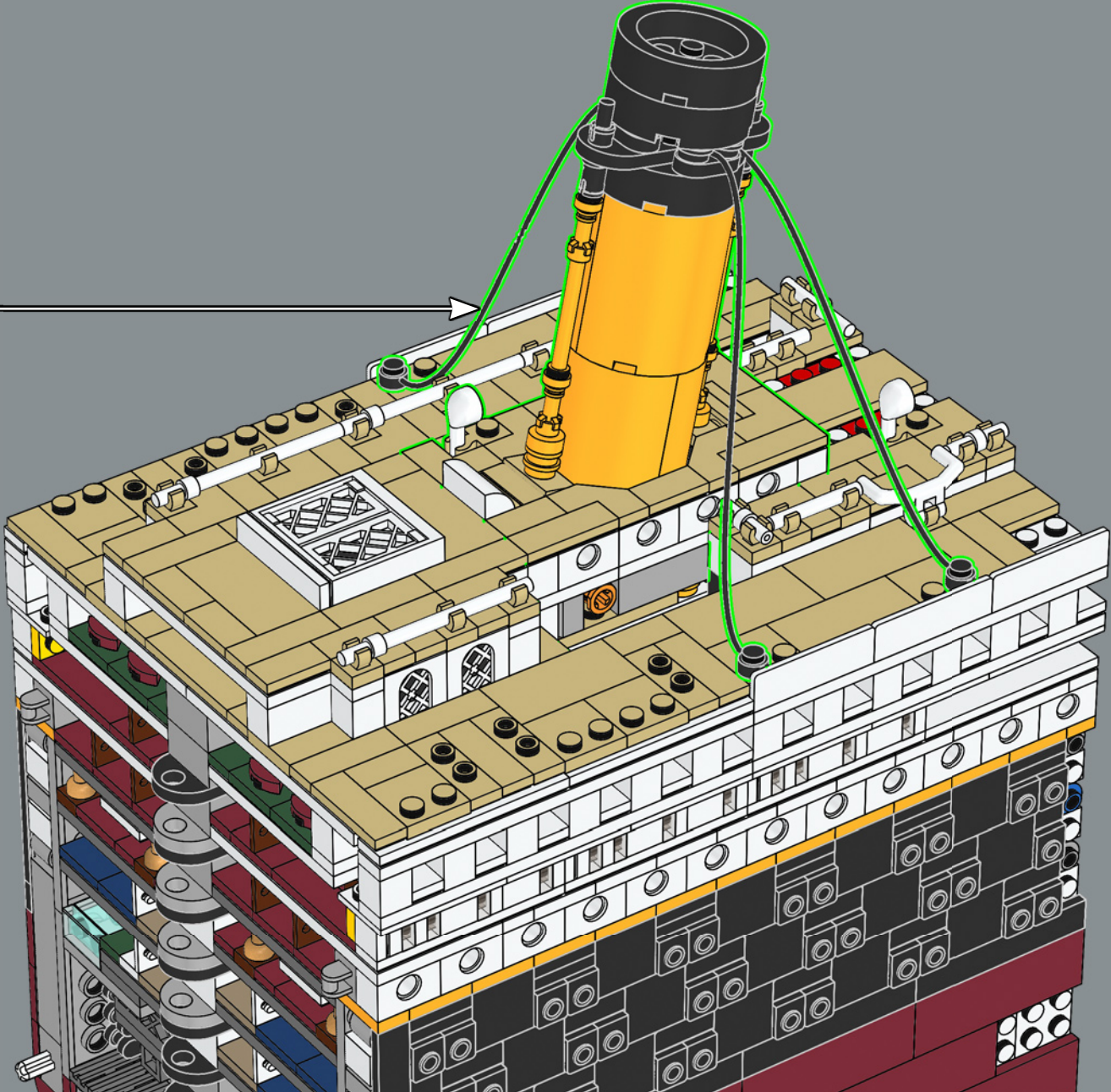

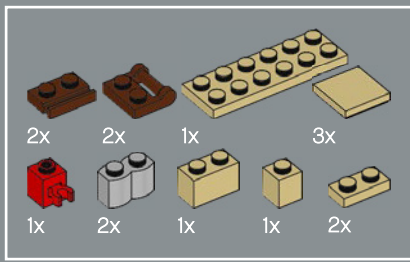

137

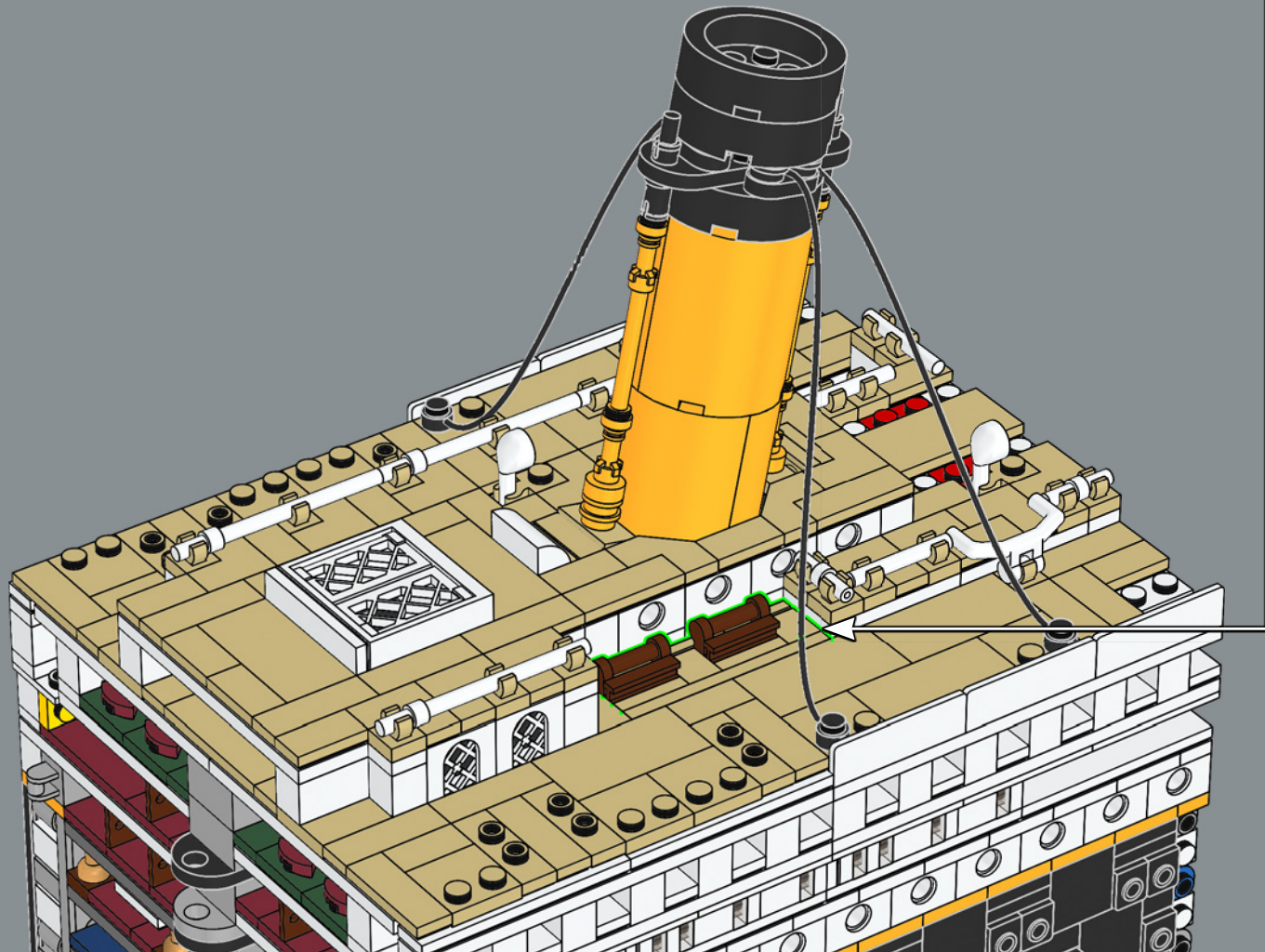
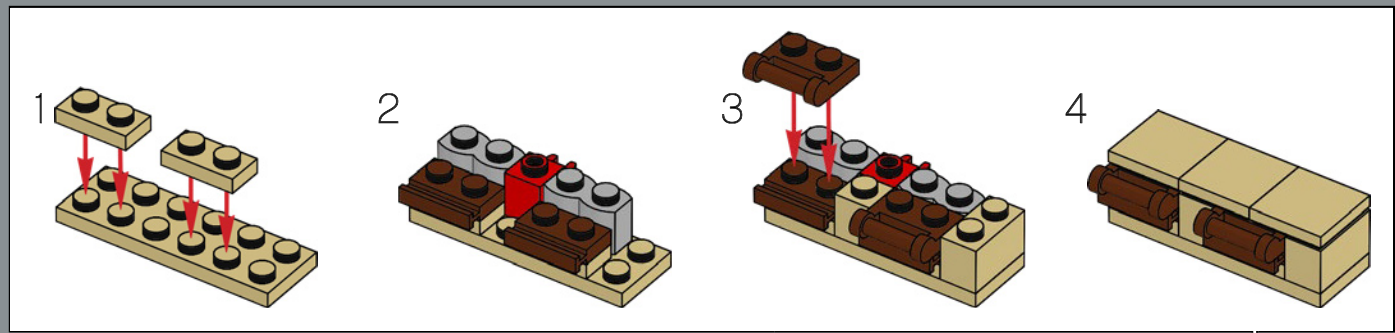

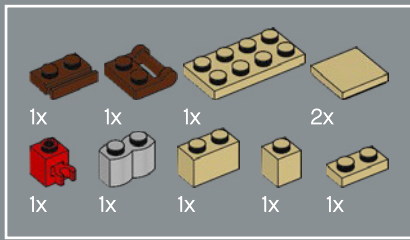

138

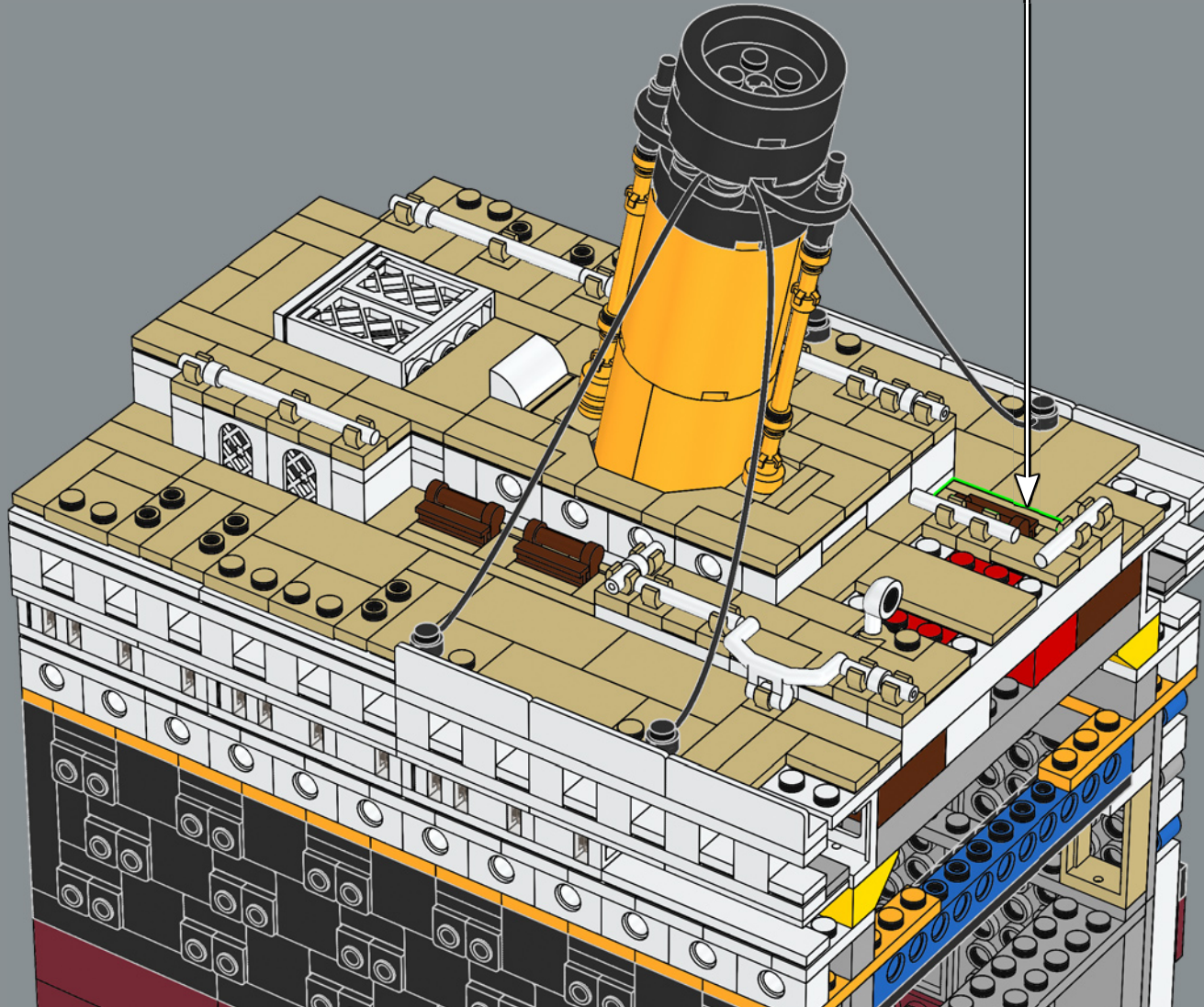
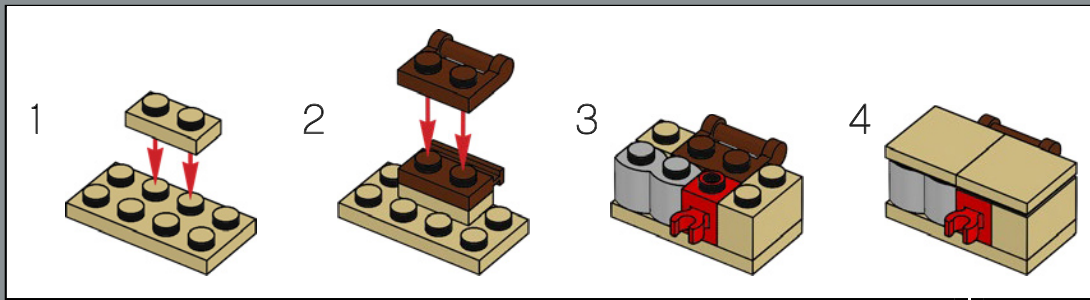

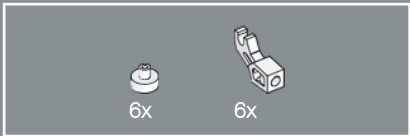

139

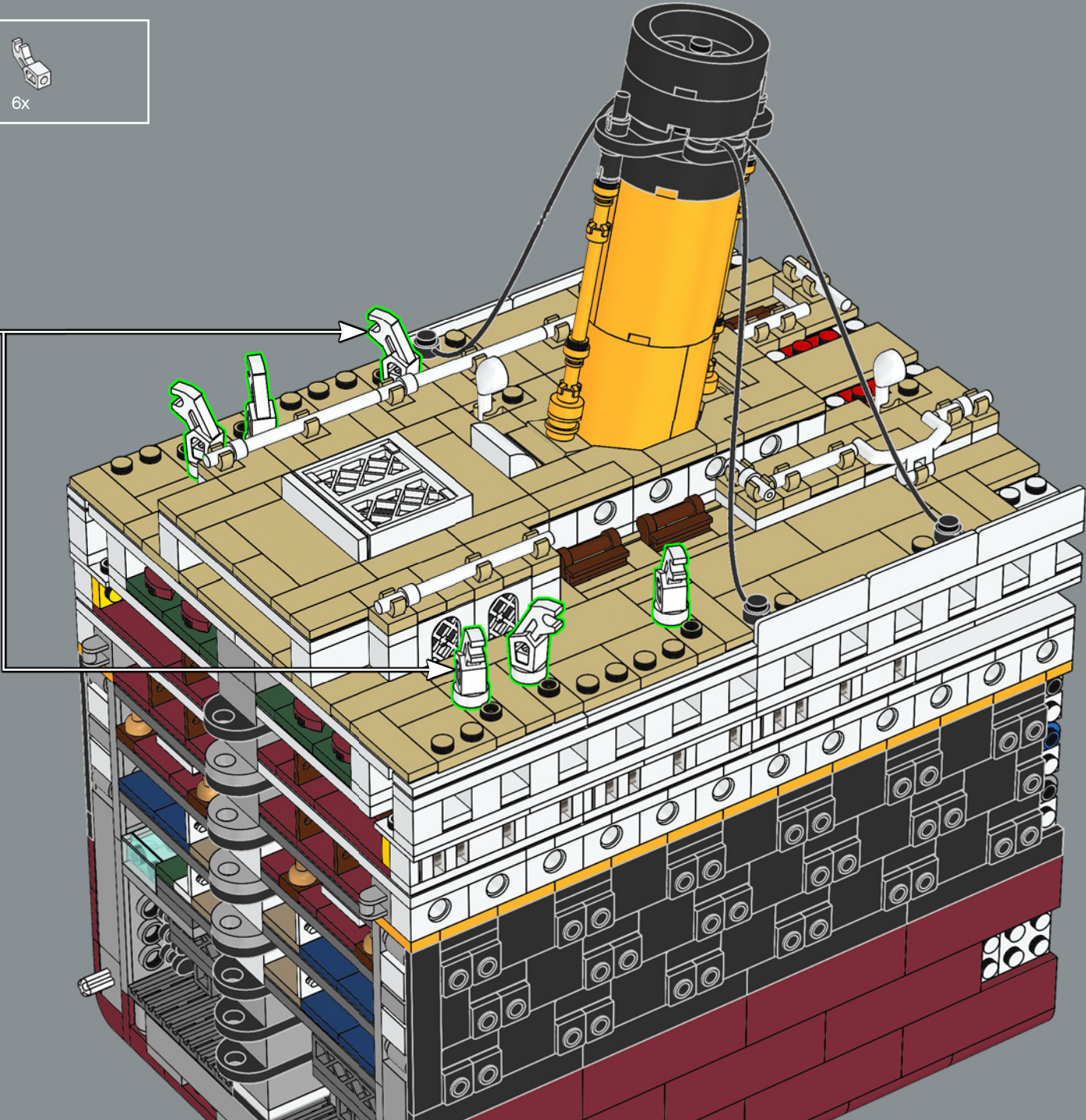
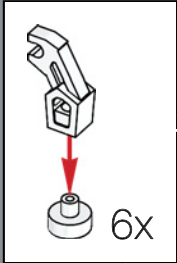

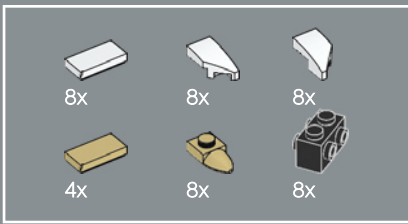

140

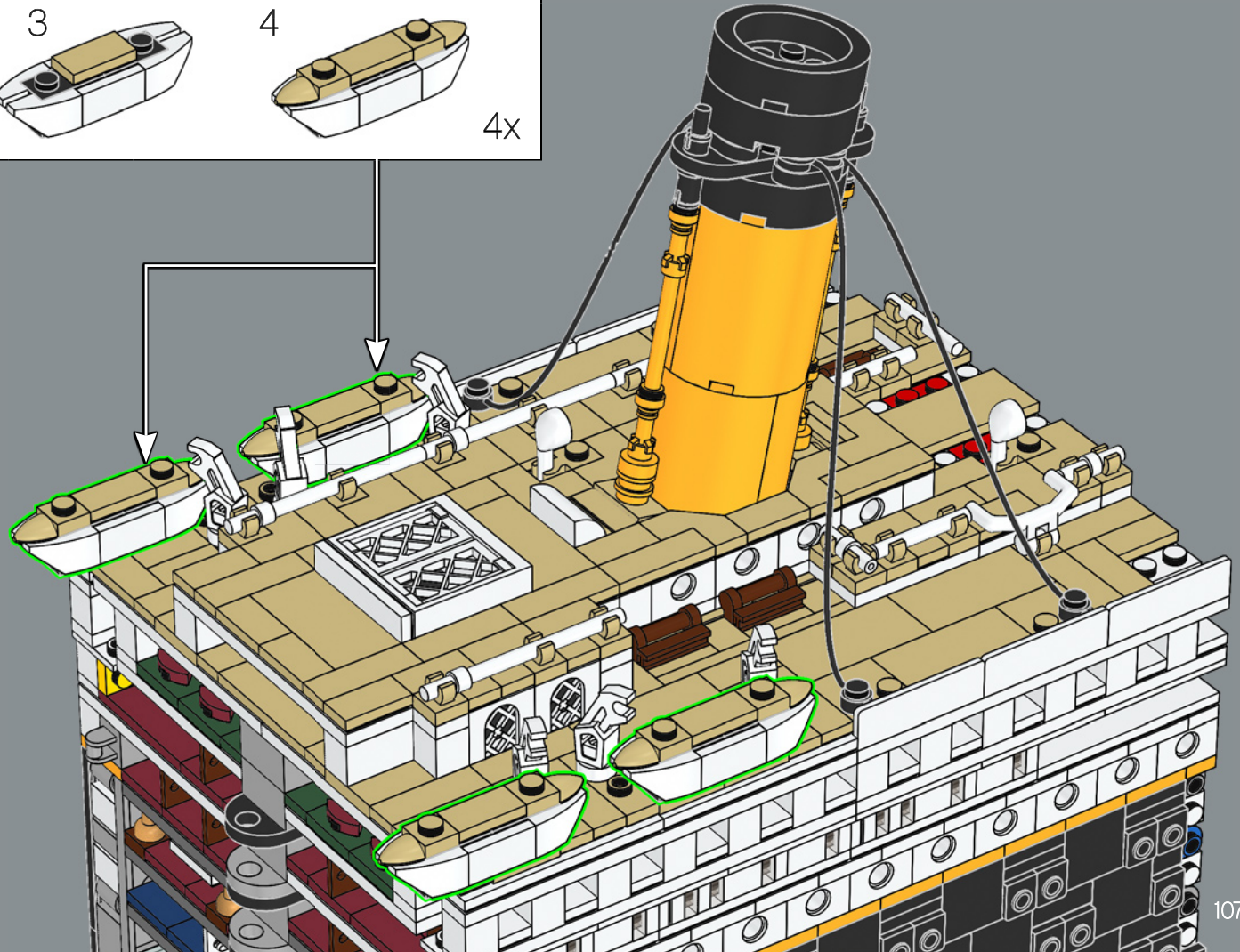
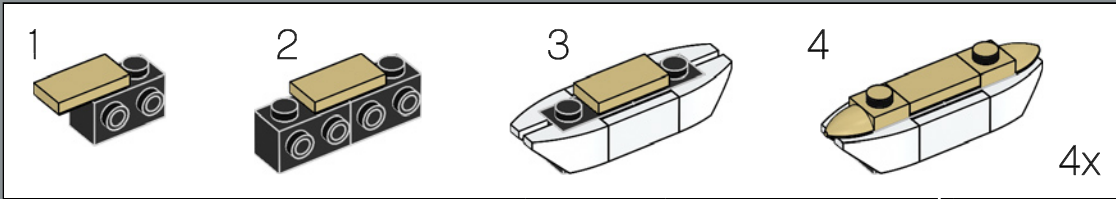

Parmi les 20 canots de sauvetage à bord,
14 sont des canots standards en bois
d'une capacité de 65 personnes, et 4 sont
des canots « pliables » pouvant accueillir
47 personnes.

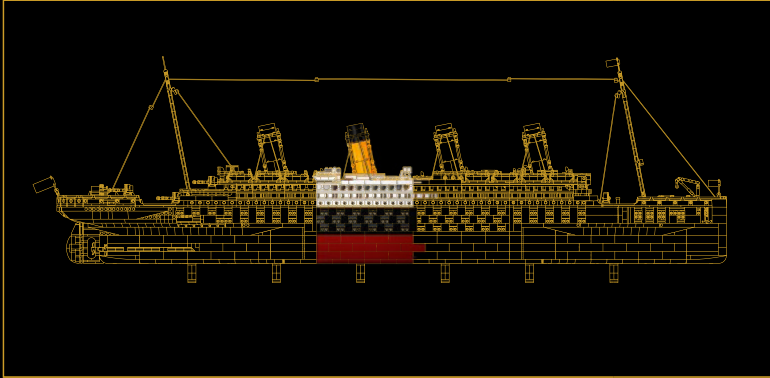

SECTION 4 :

CHEMINÉE ET BOUSSOLE

Cette section comprend une partie des énormes salles des machines du Titanic ainsi que la structure surélevée au centre où se trouve la boussole principale. La boussole est placée en hauteur pour réduire l'interférence causée par l'importante quantité de fer dans la coque du paquebot. Il y a aussi un petit sous-ensemble représentant un banc utilisé par des passagers qui profitent des ponts supérieurs du navire.



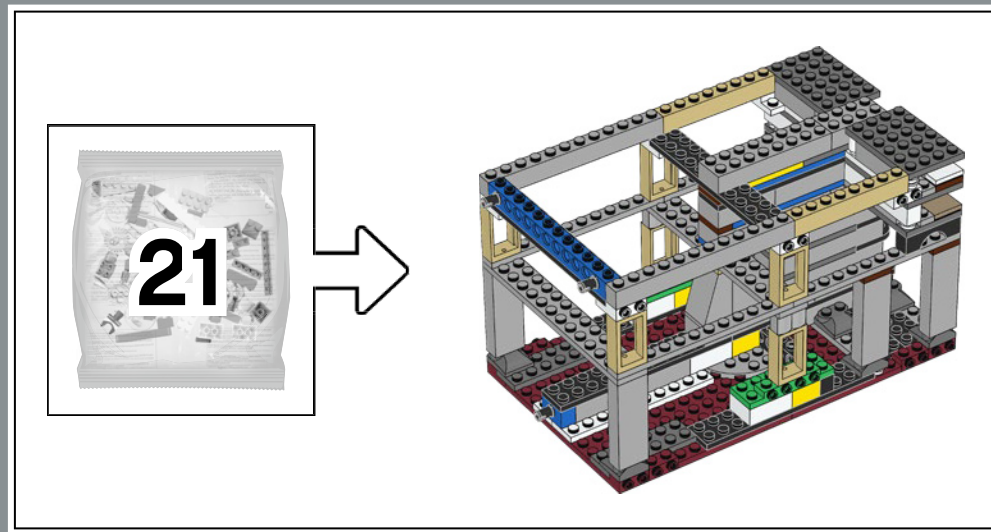

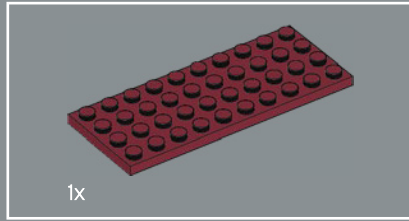
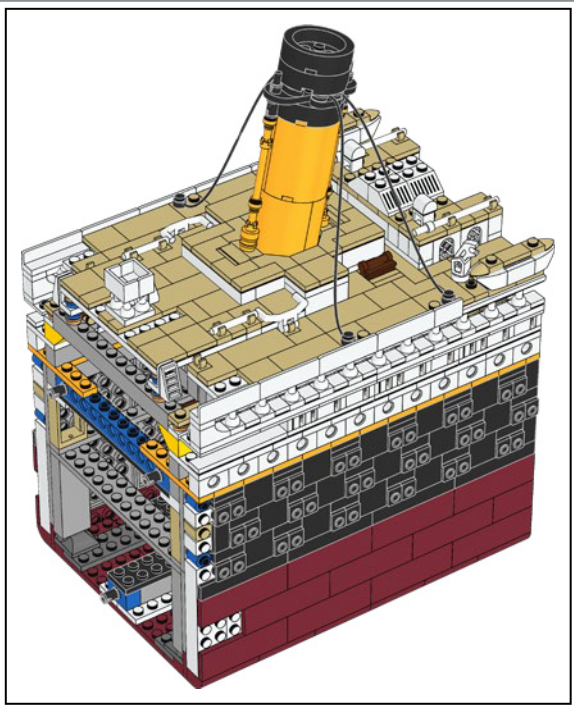

141

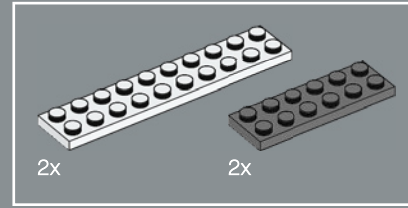
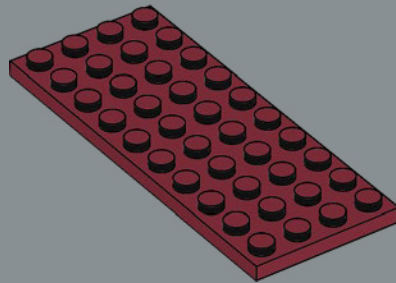

142

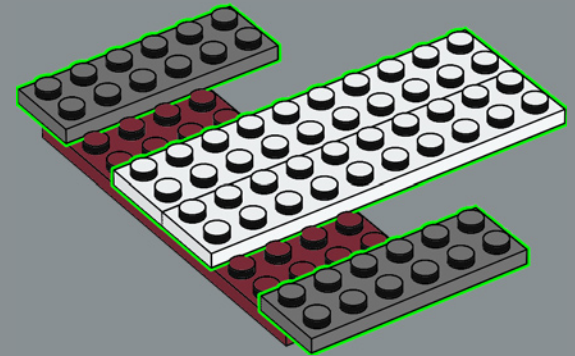

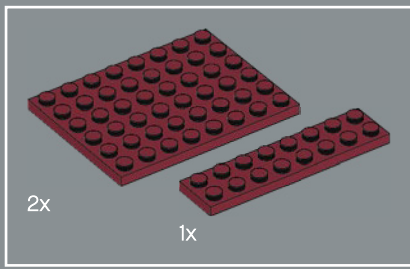

143

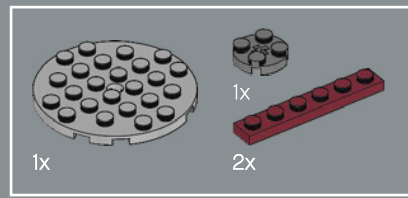
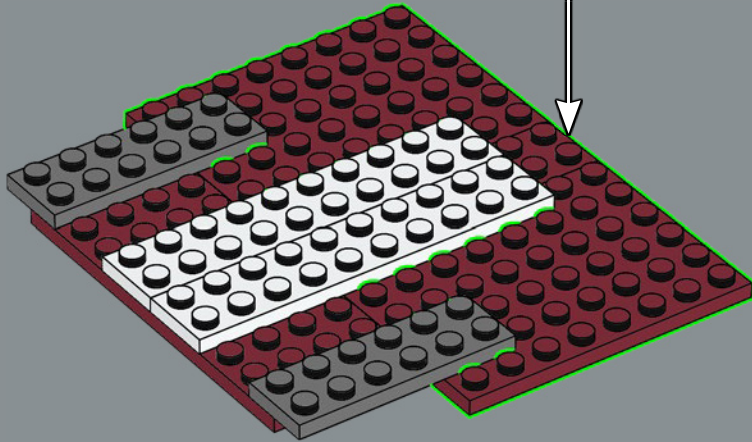
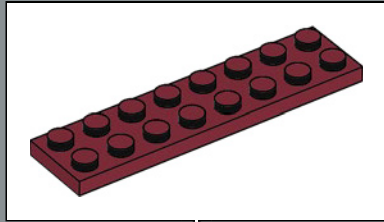

144

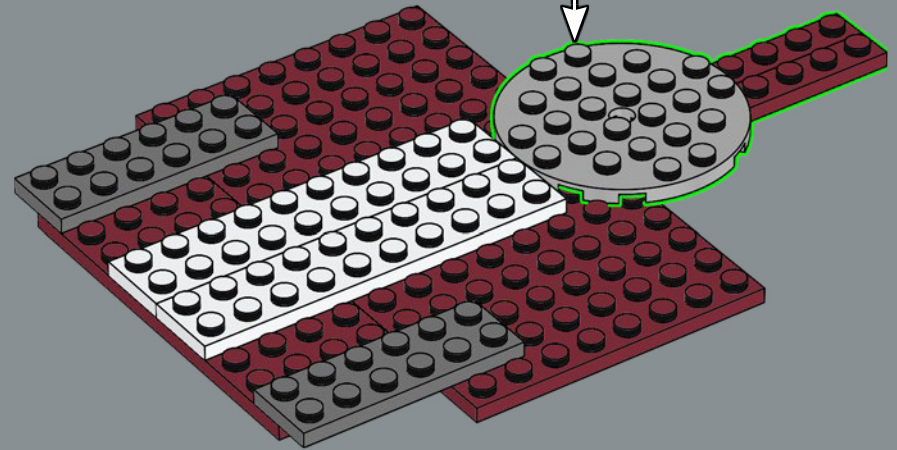
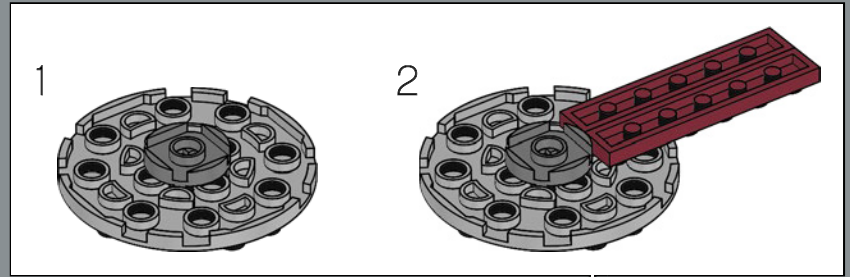

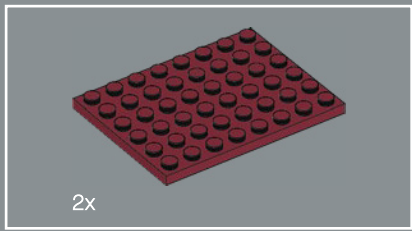

145

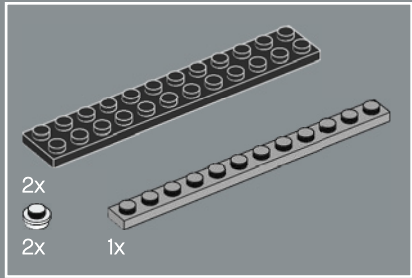
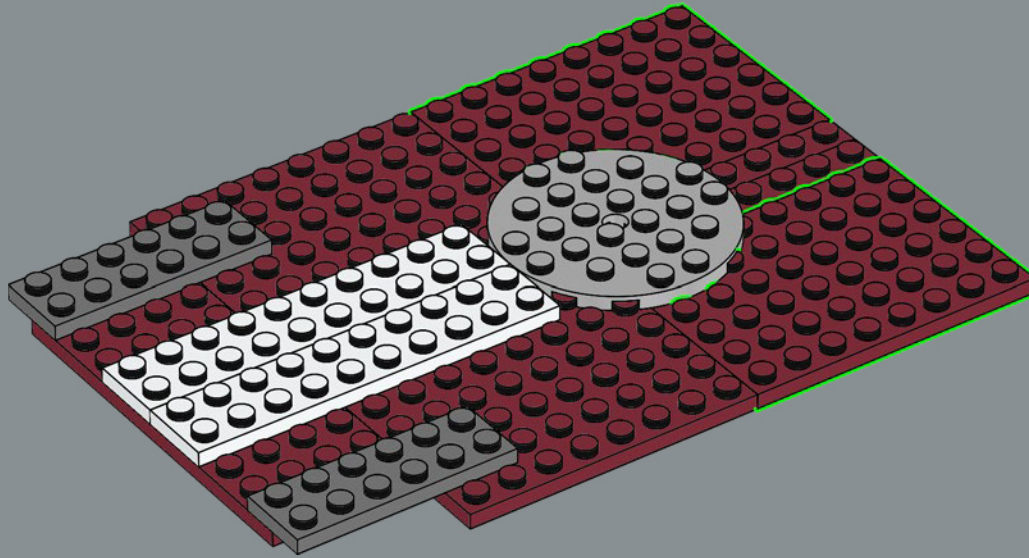

146

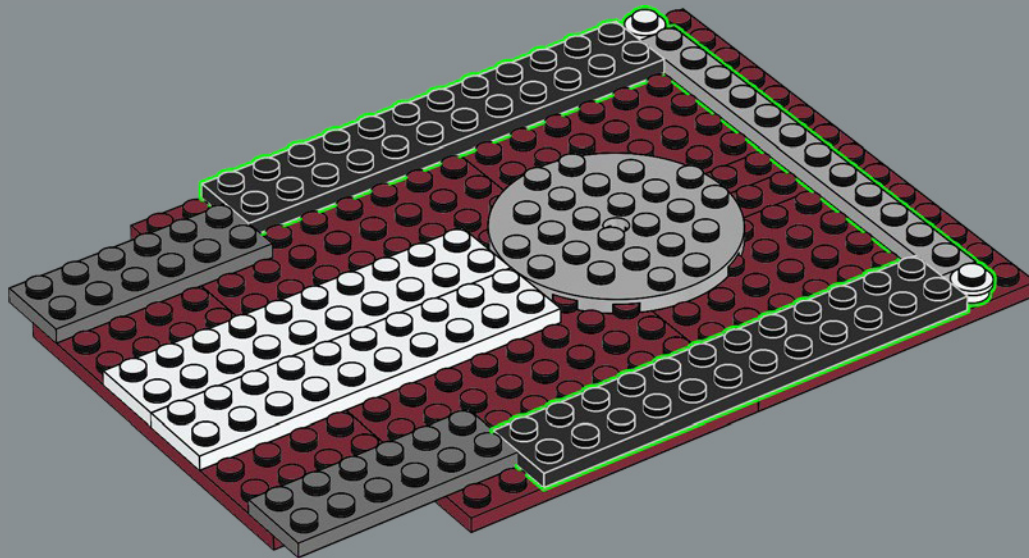

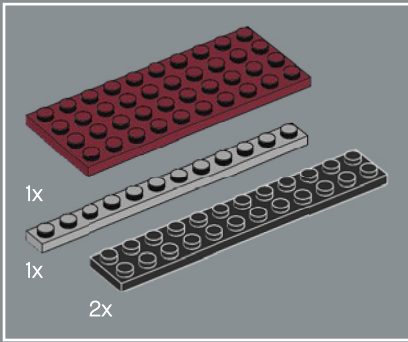

147

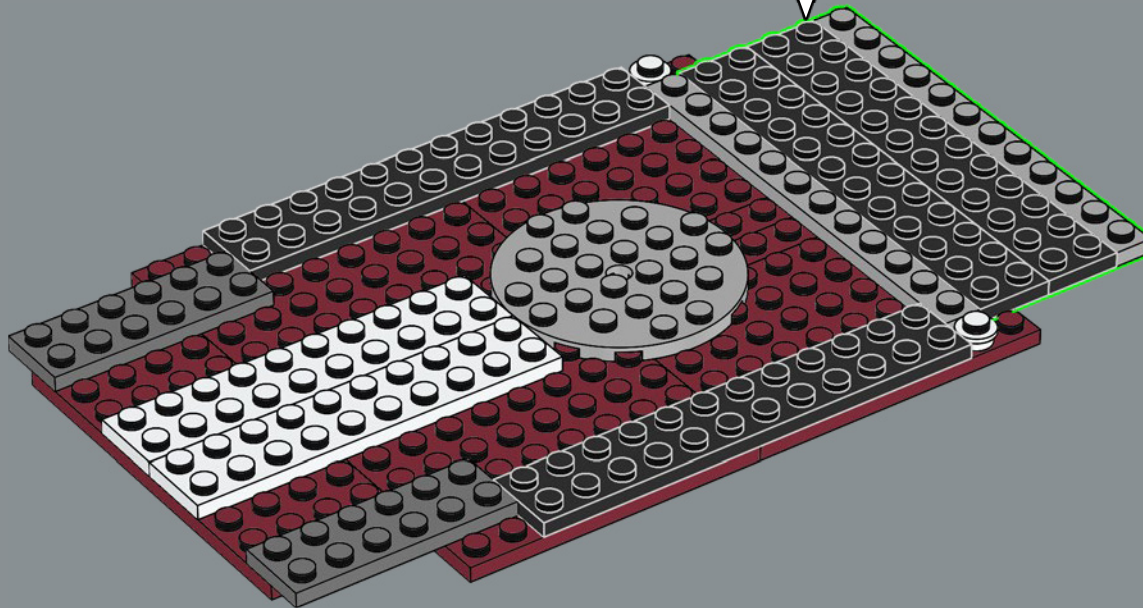
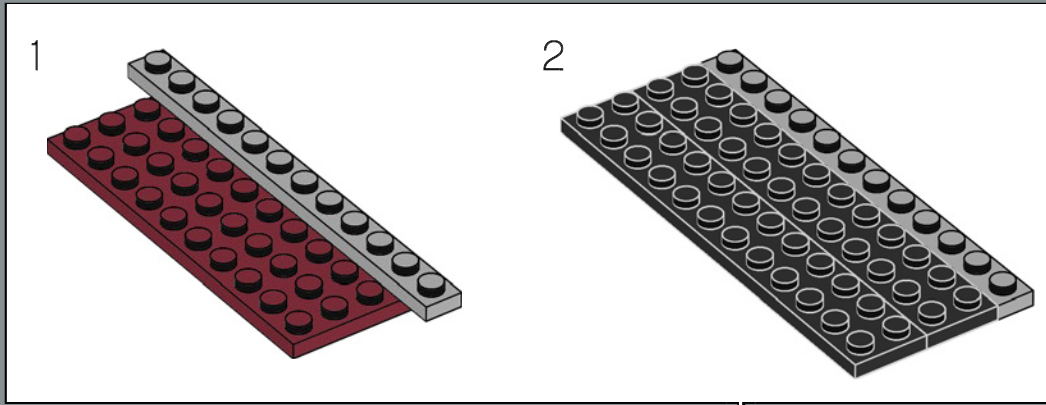



148

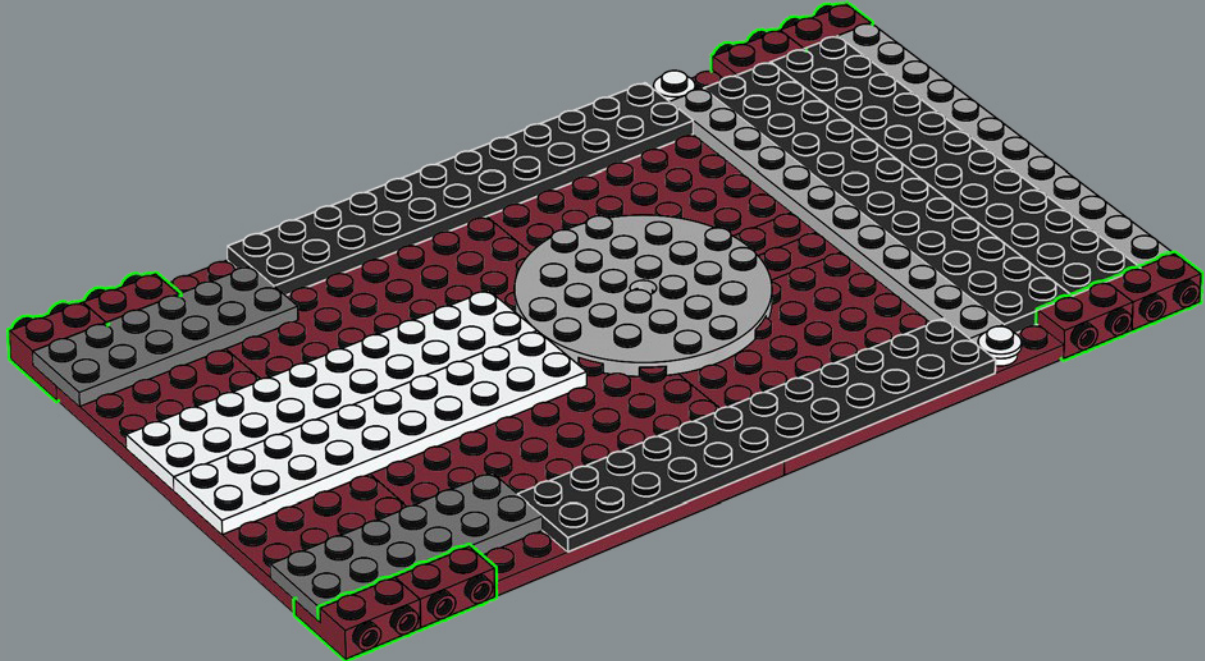

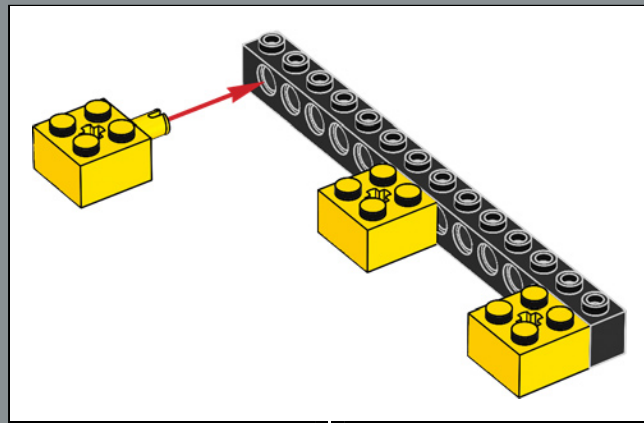
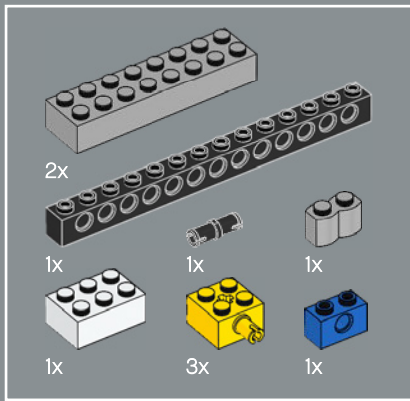

149

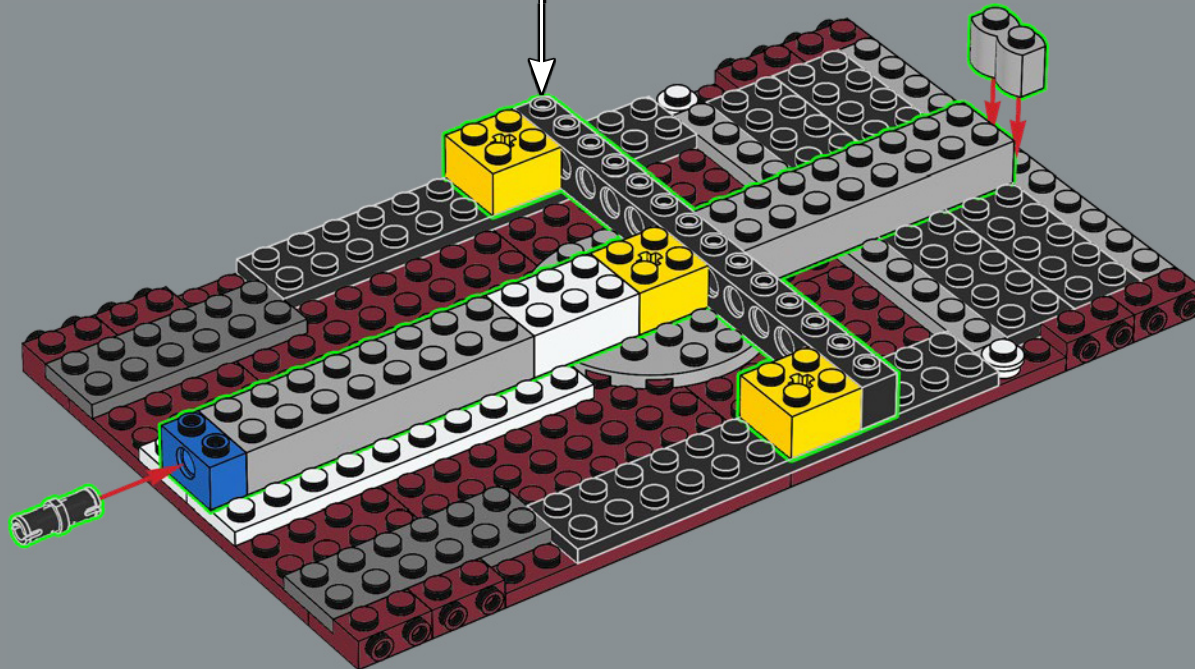

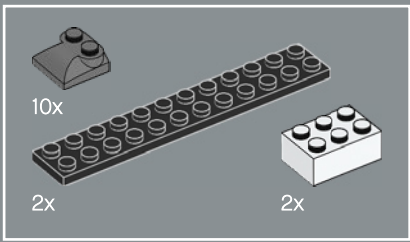

150

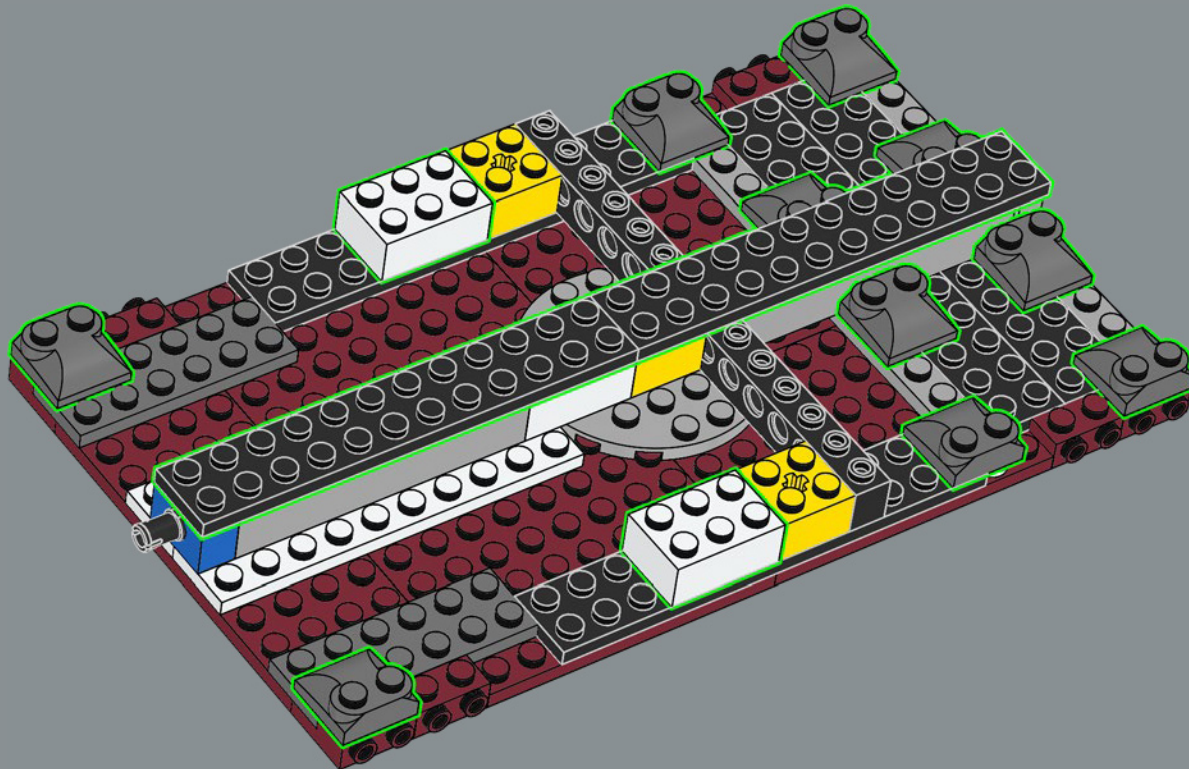

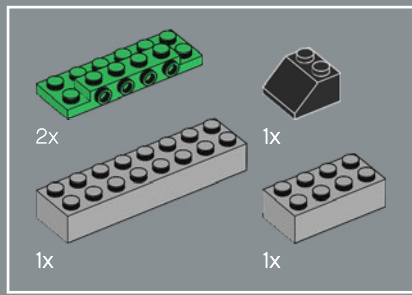

151

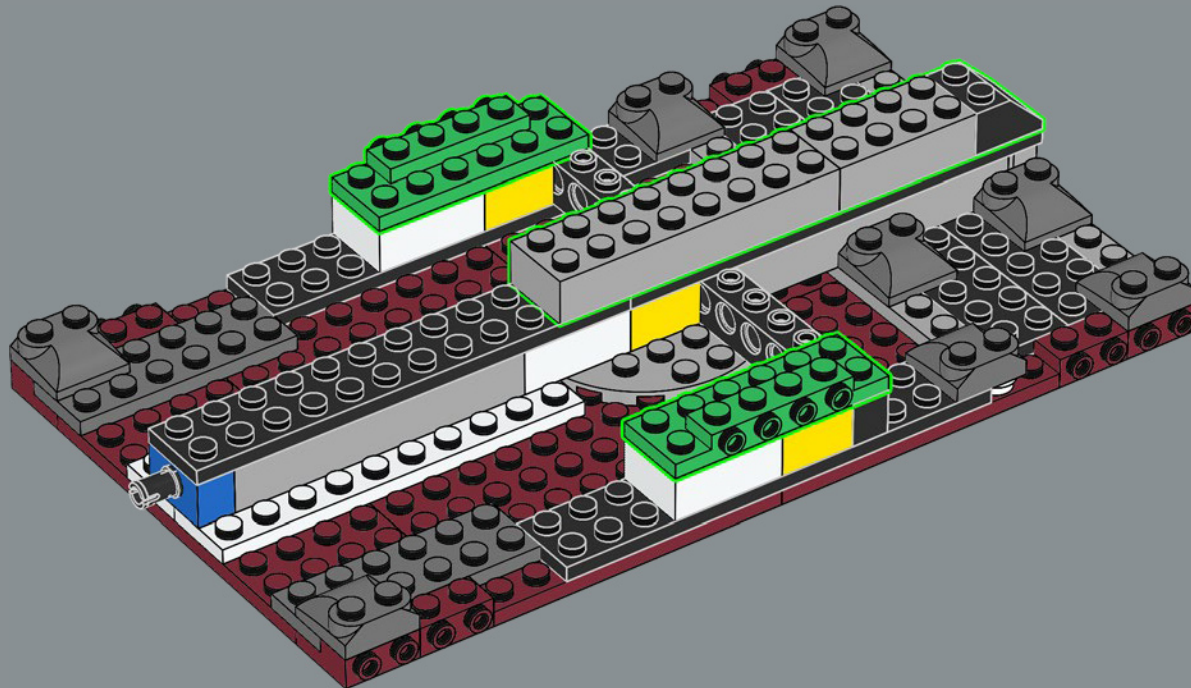

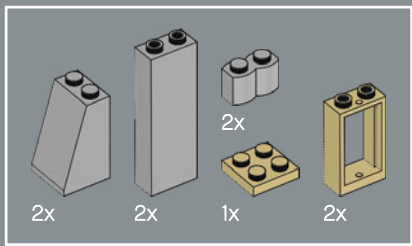

152

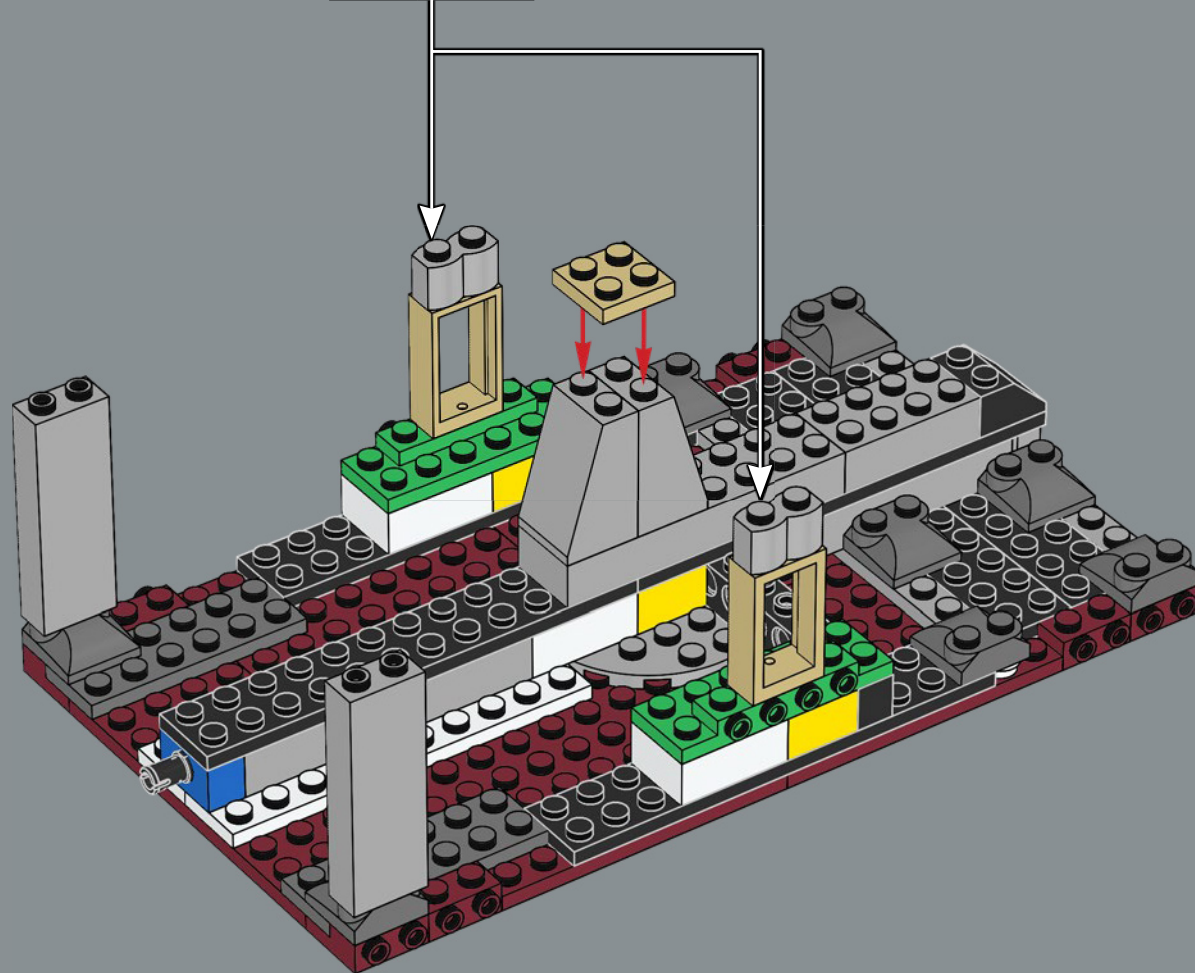
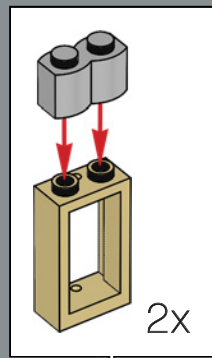

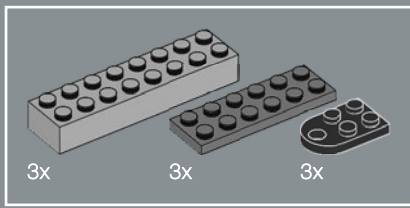

153

1

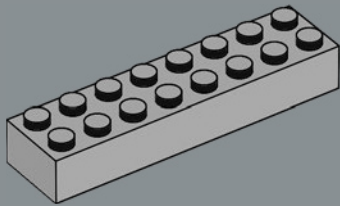

2

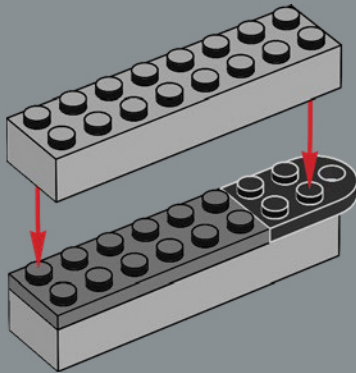

3

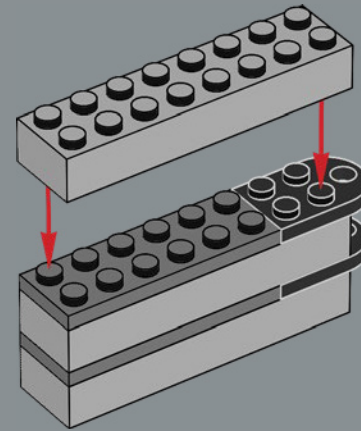

4

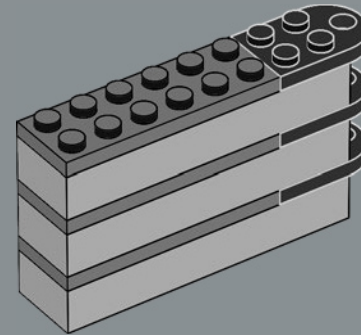

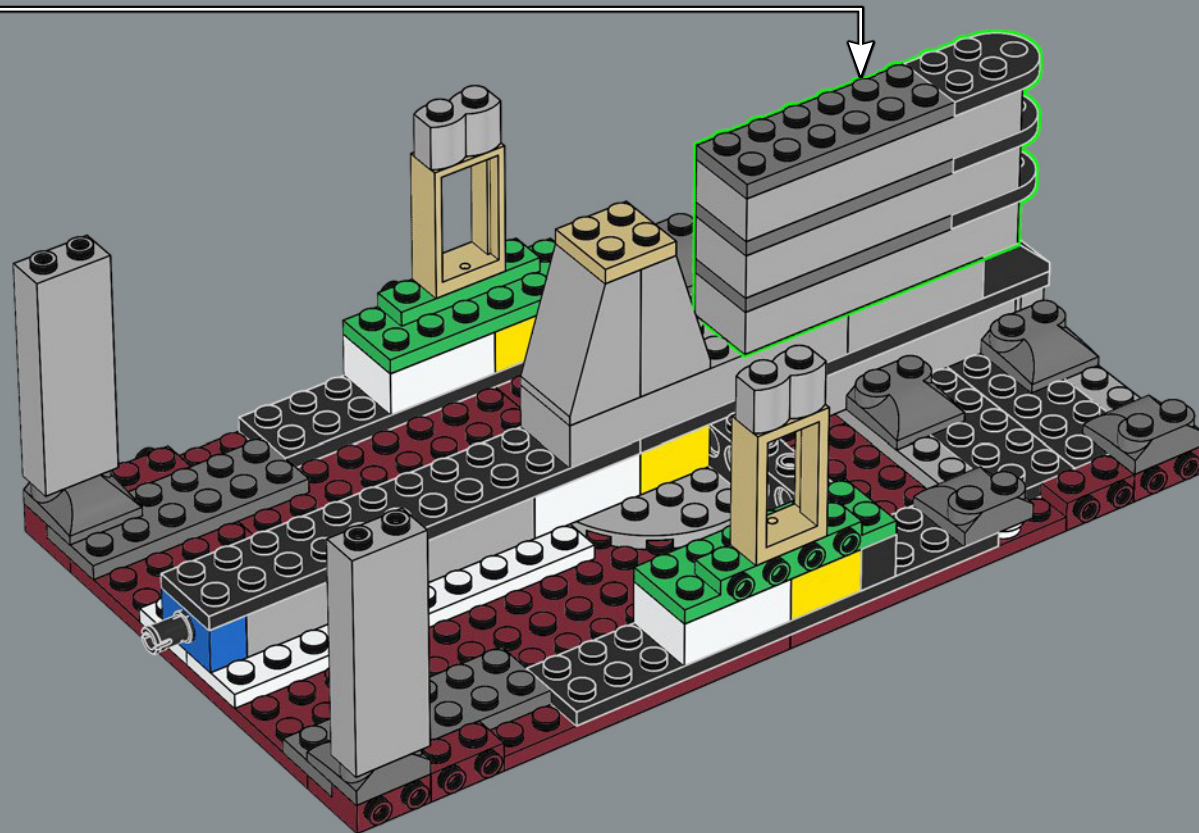

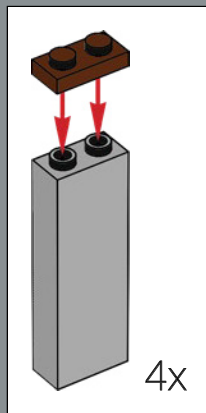
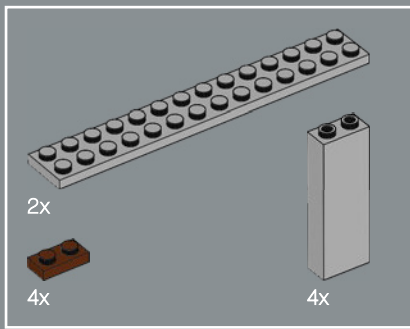

154

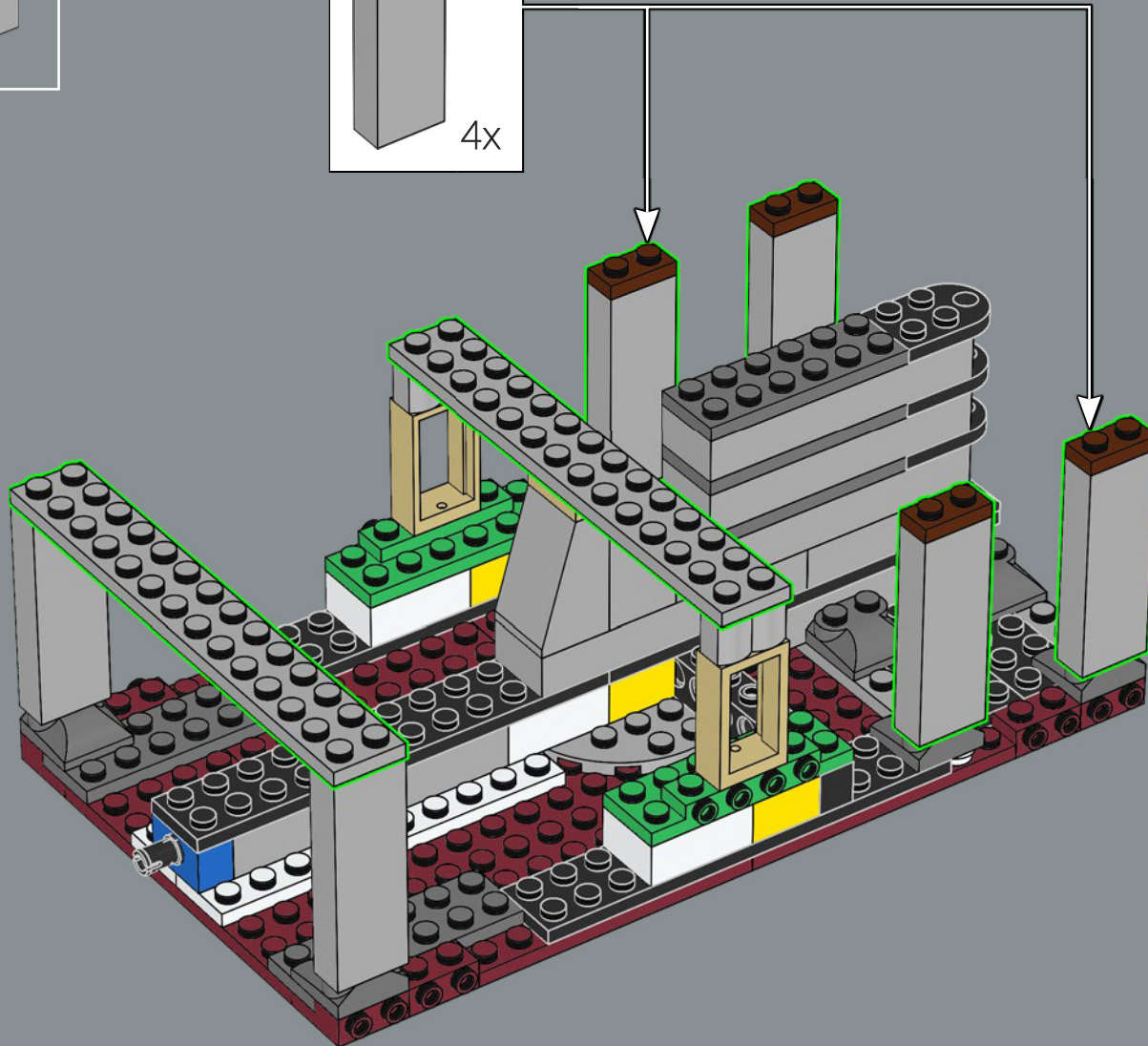

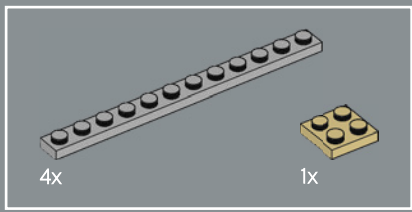

155

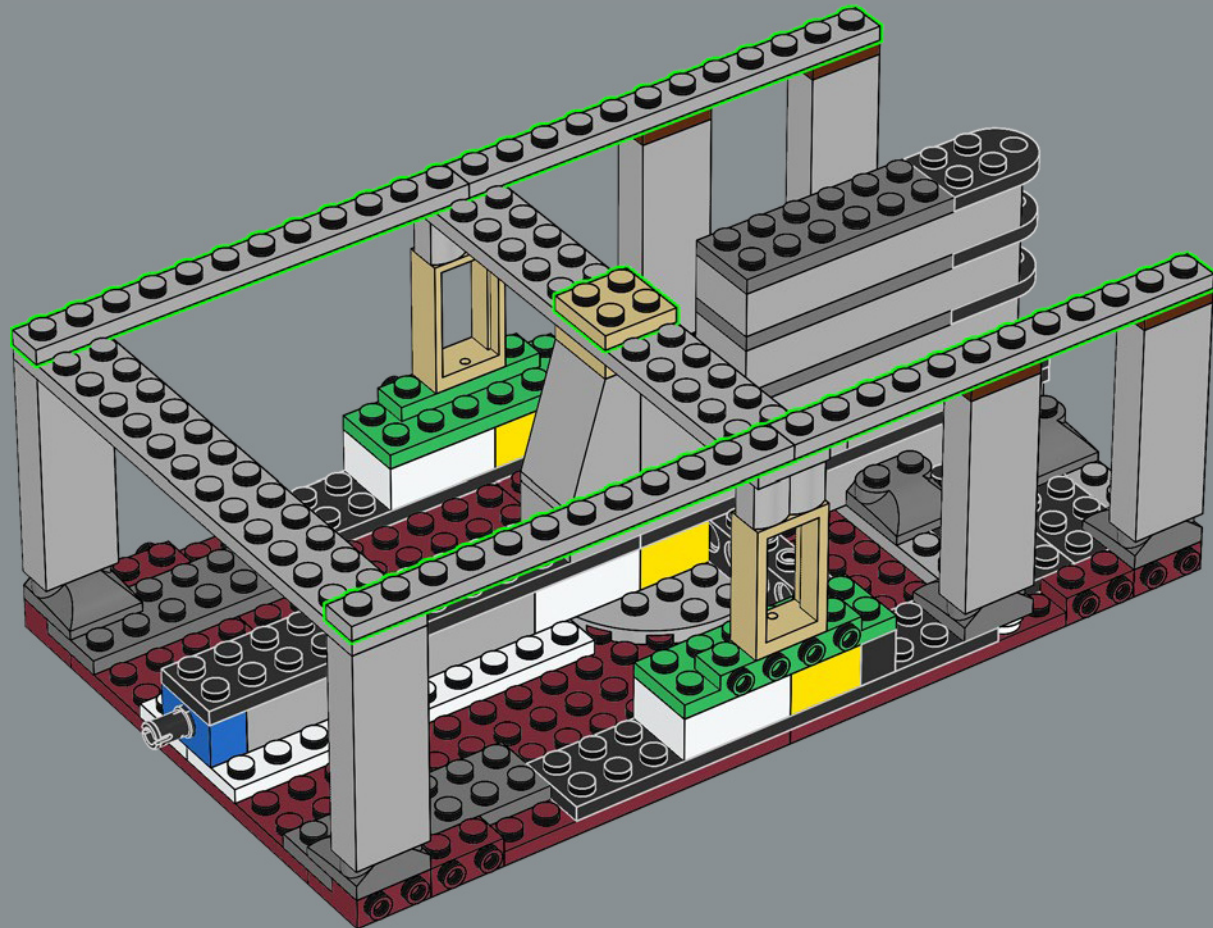

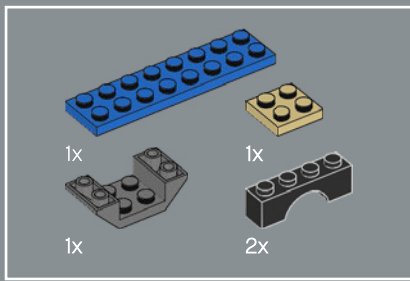

156

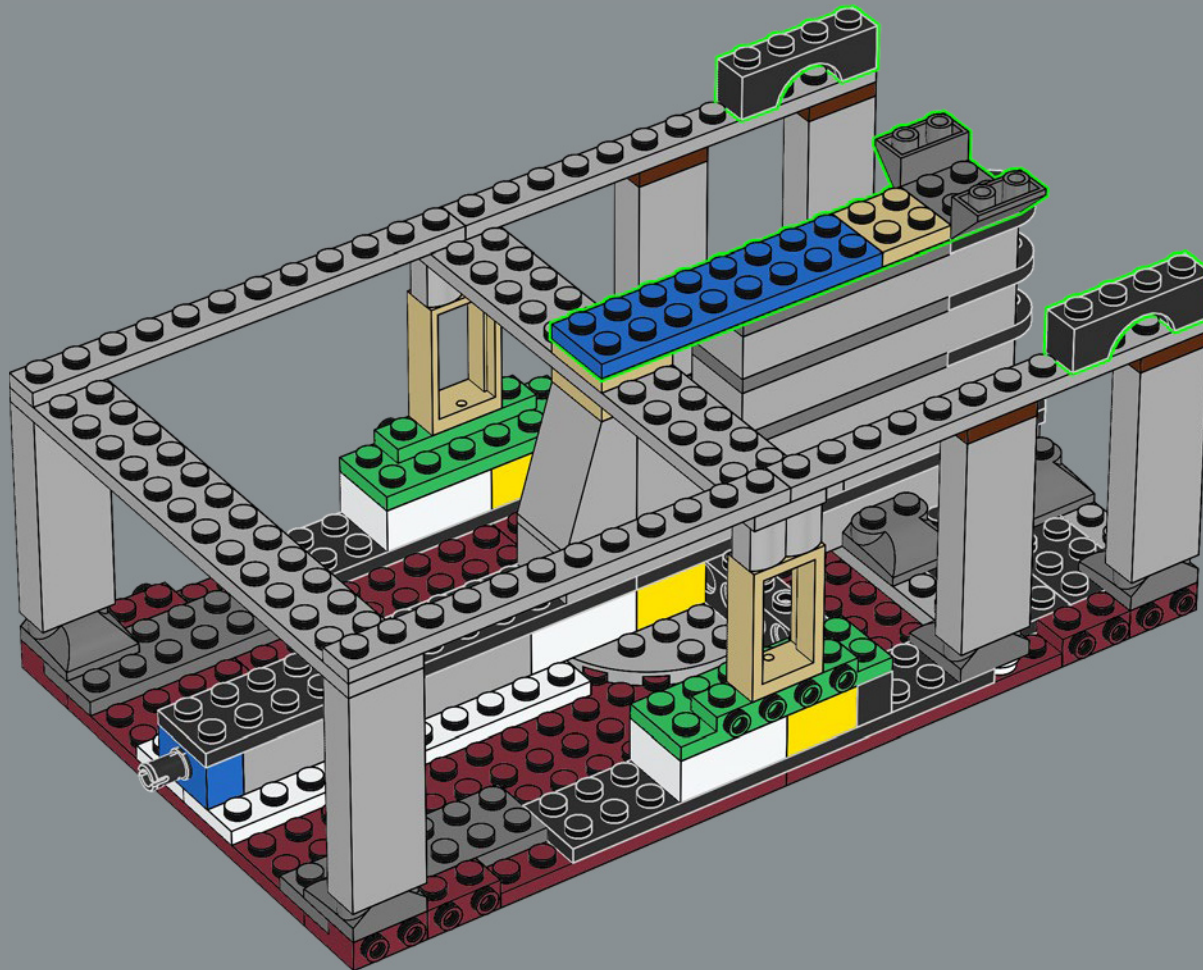

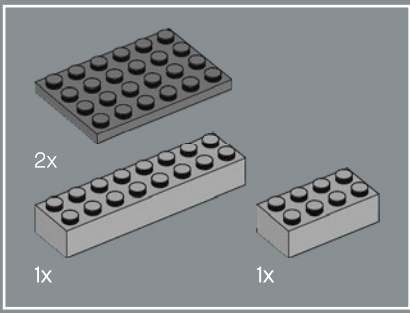

157

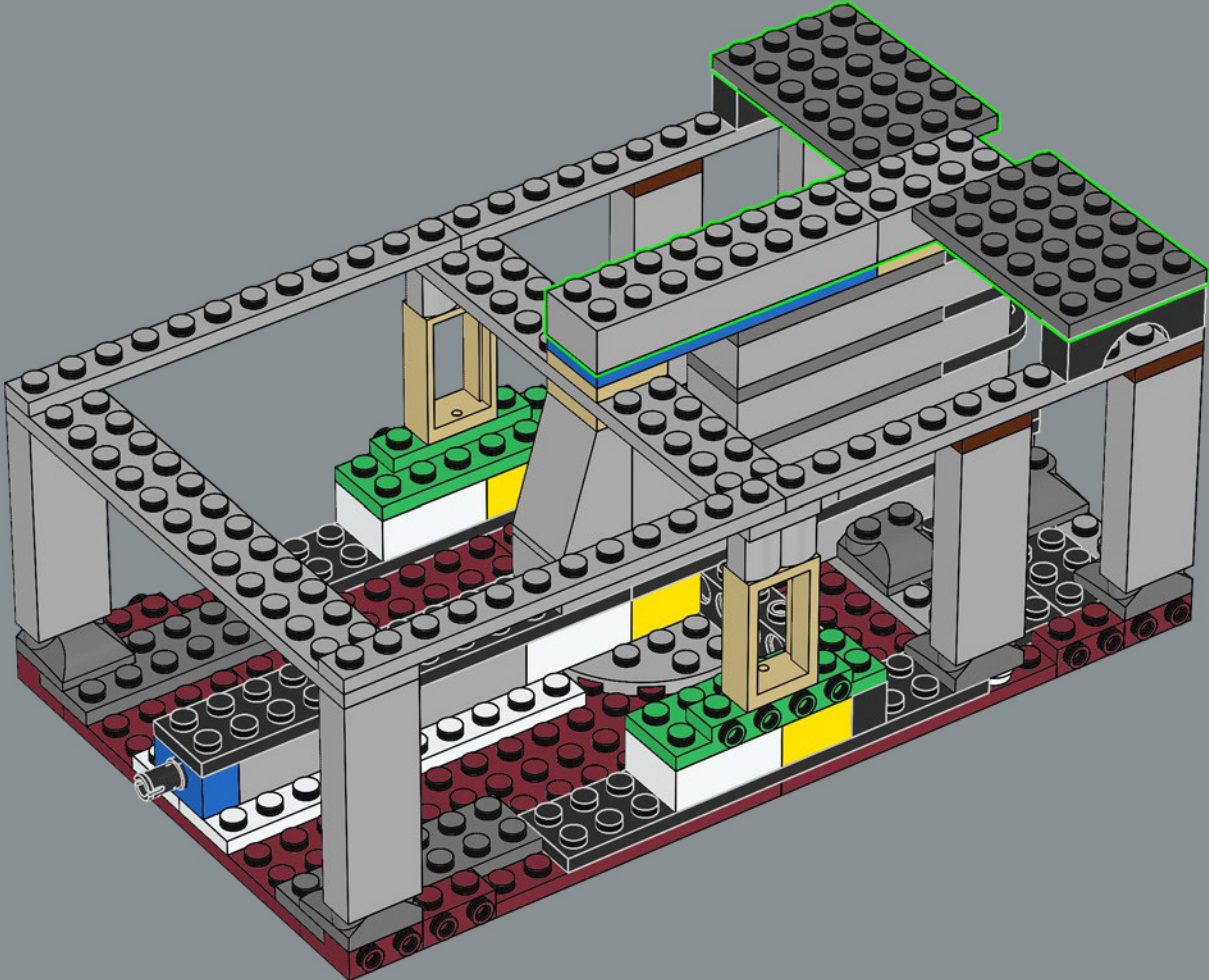

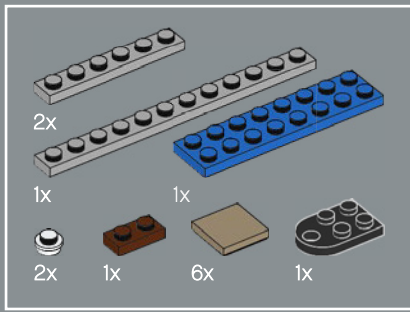

158

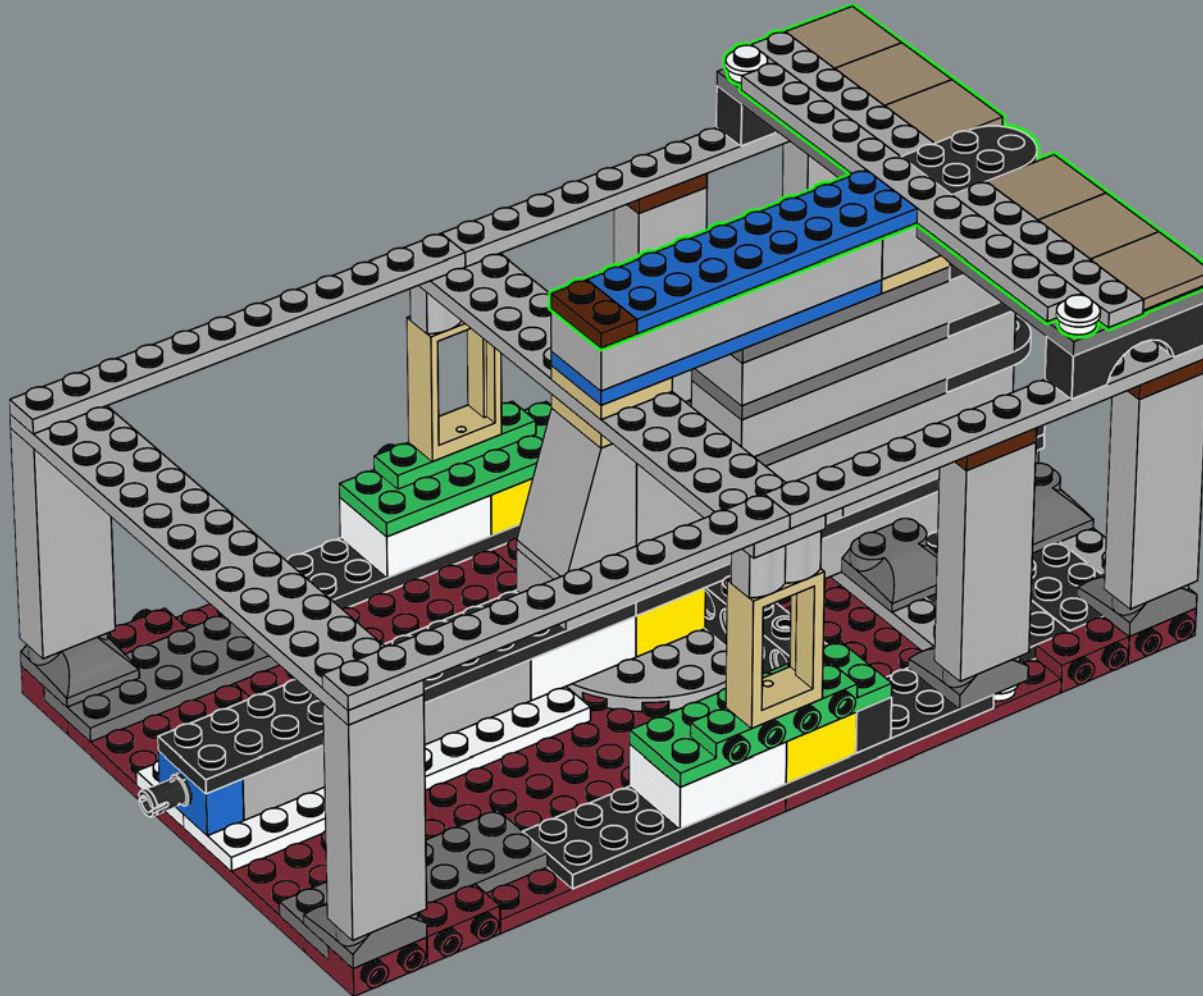

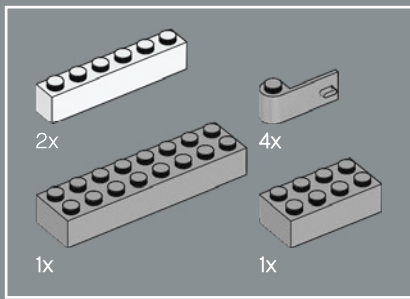

159

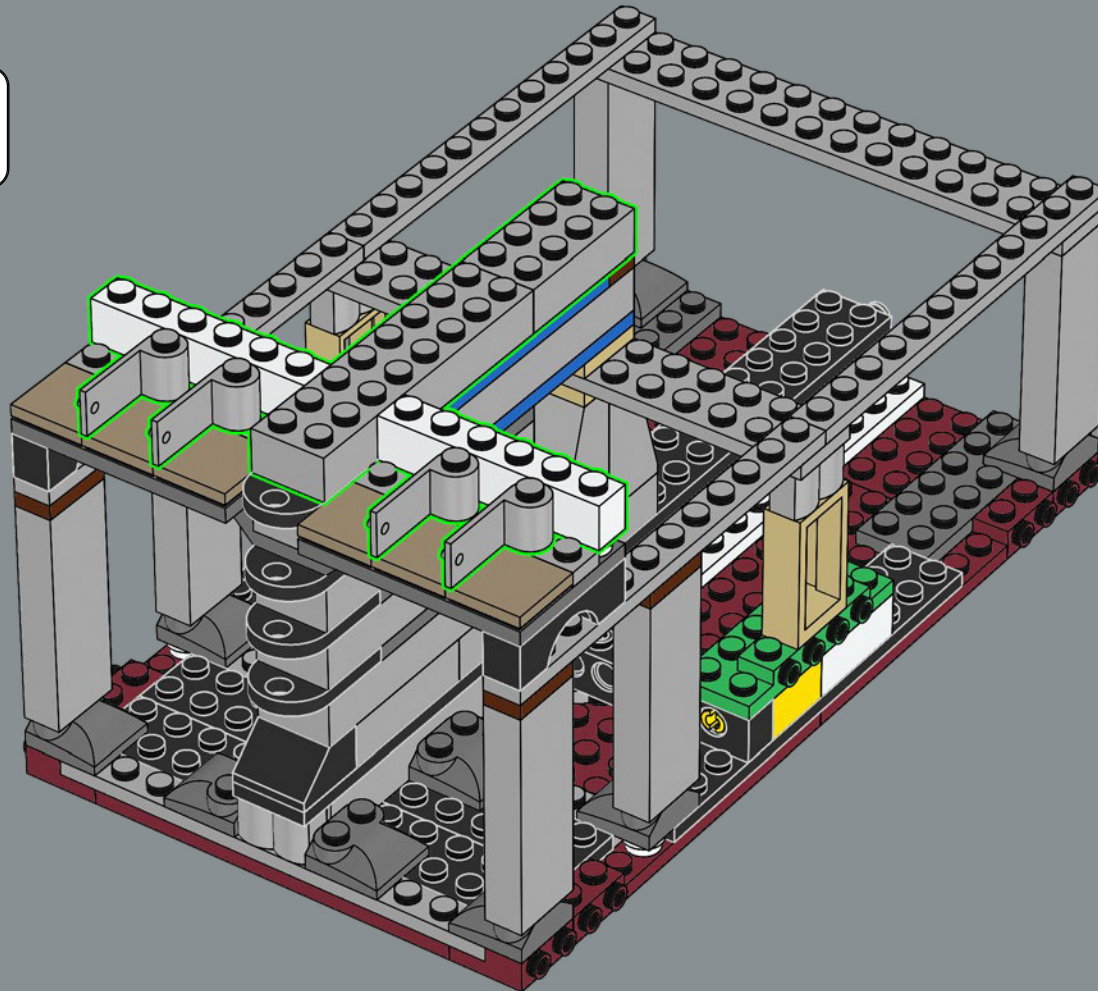

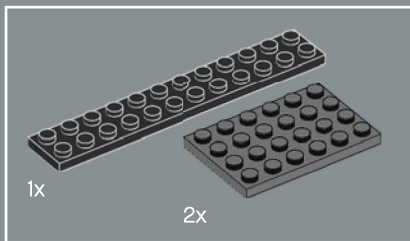

160

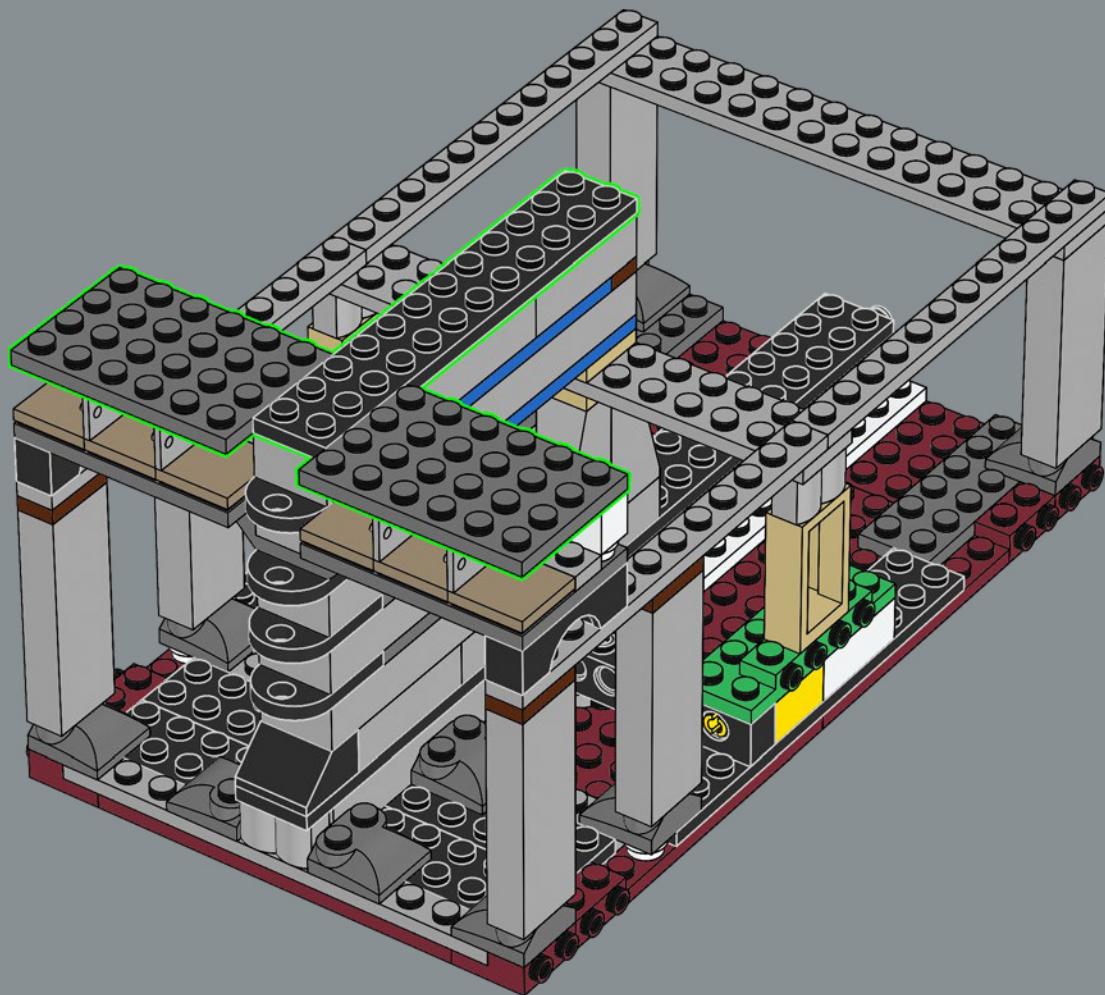

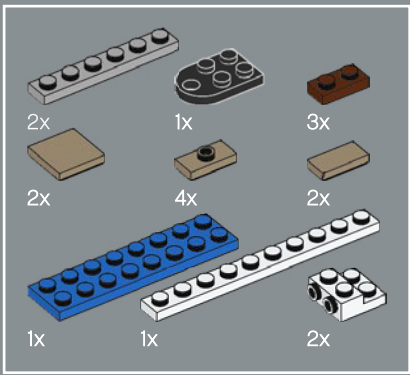

161

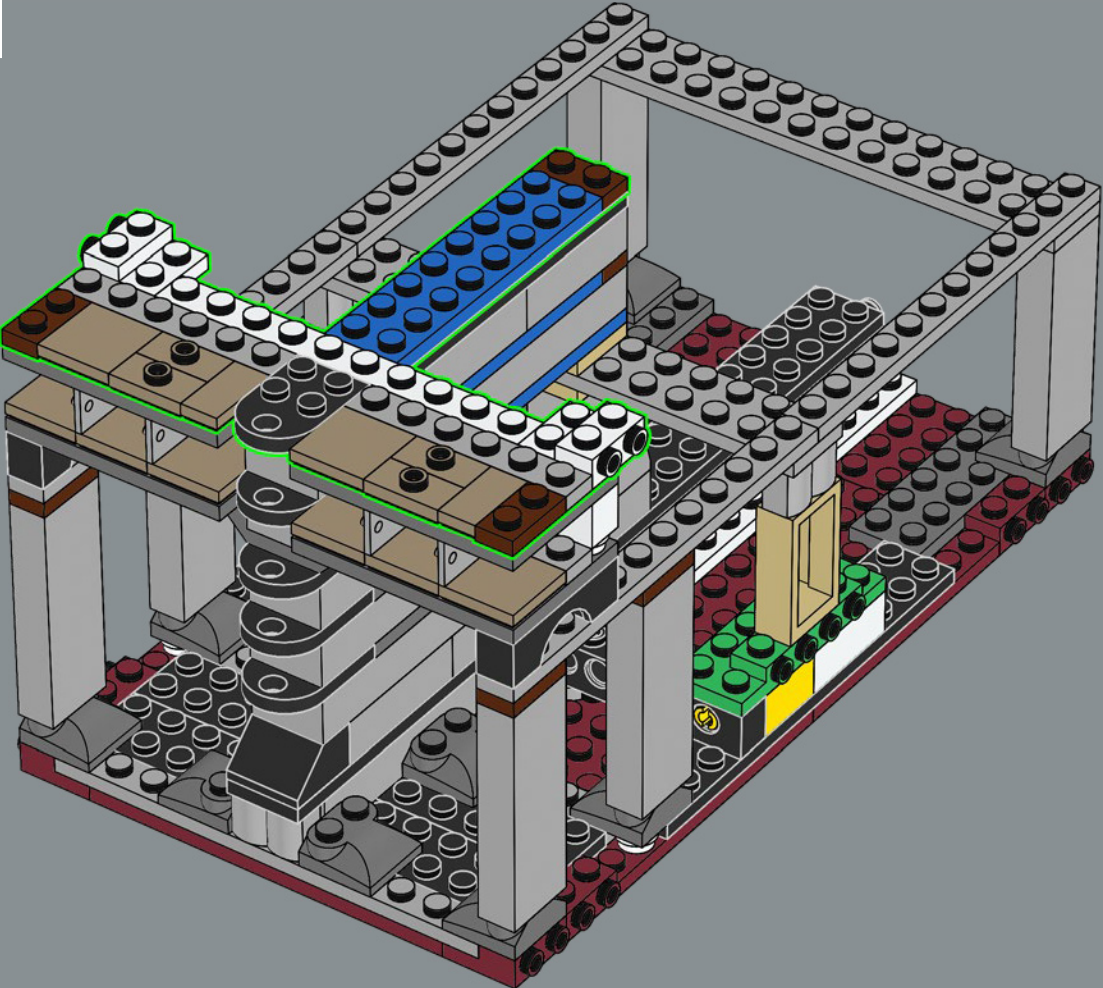

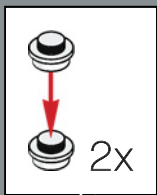
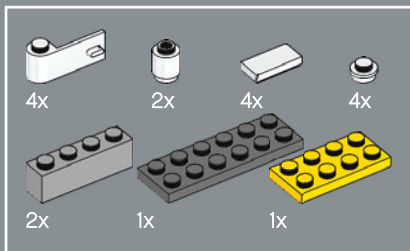

162

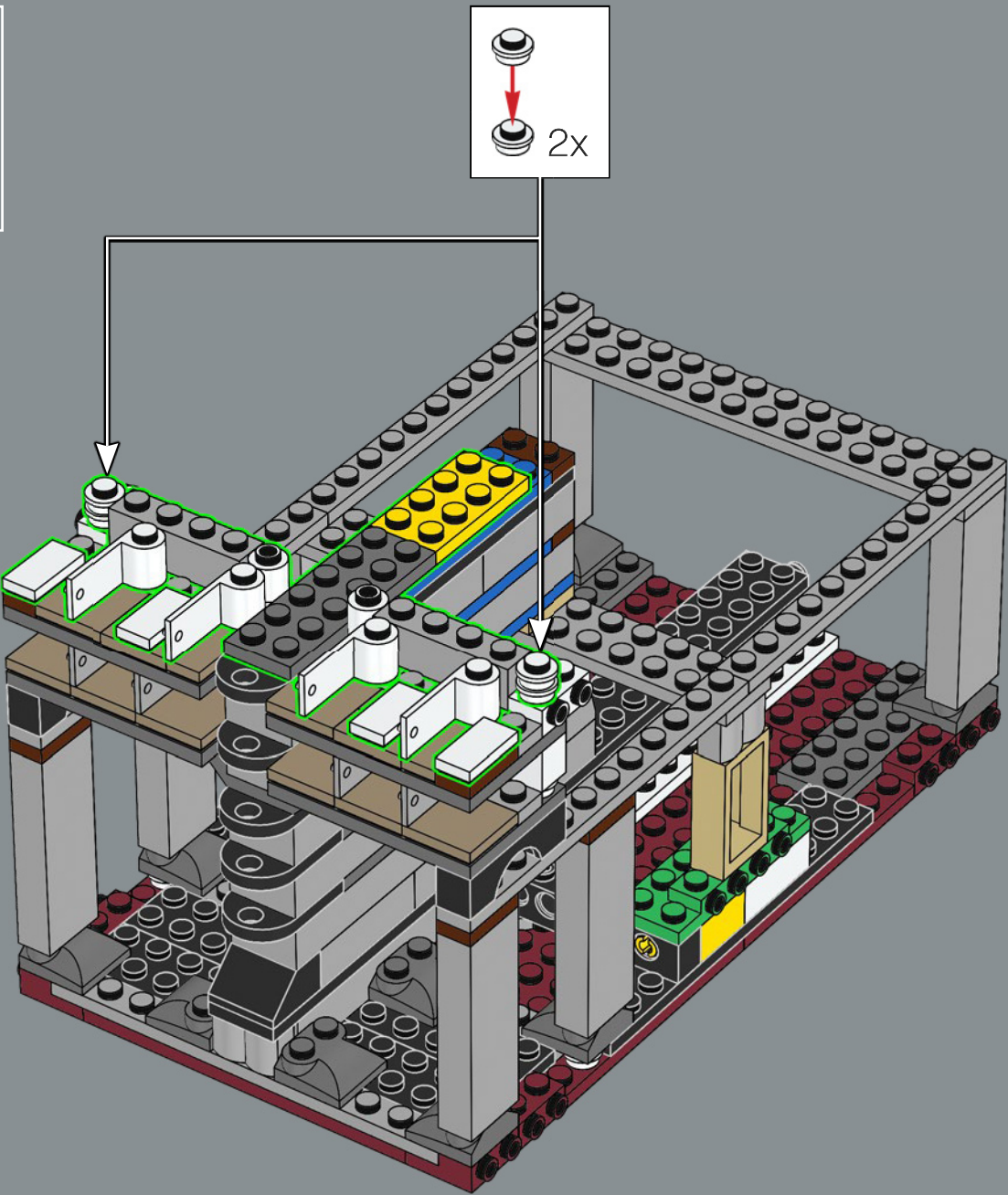

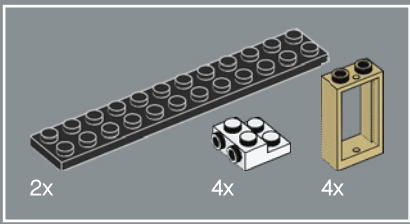

163

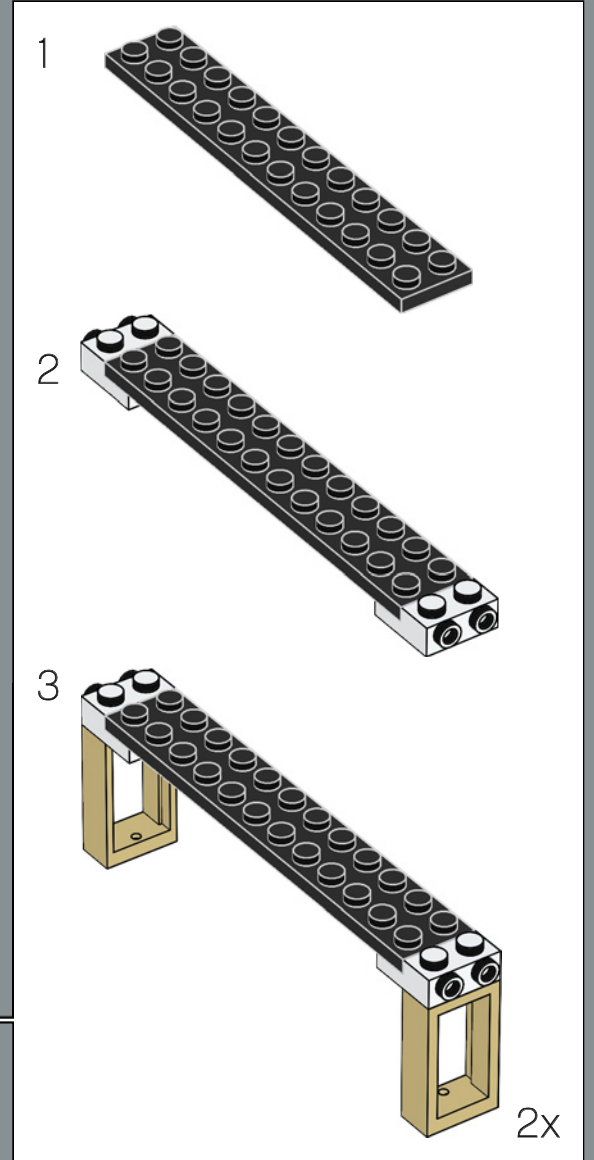
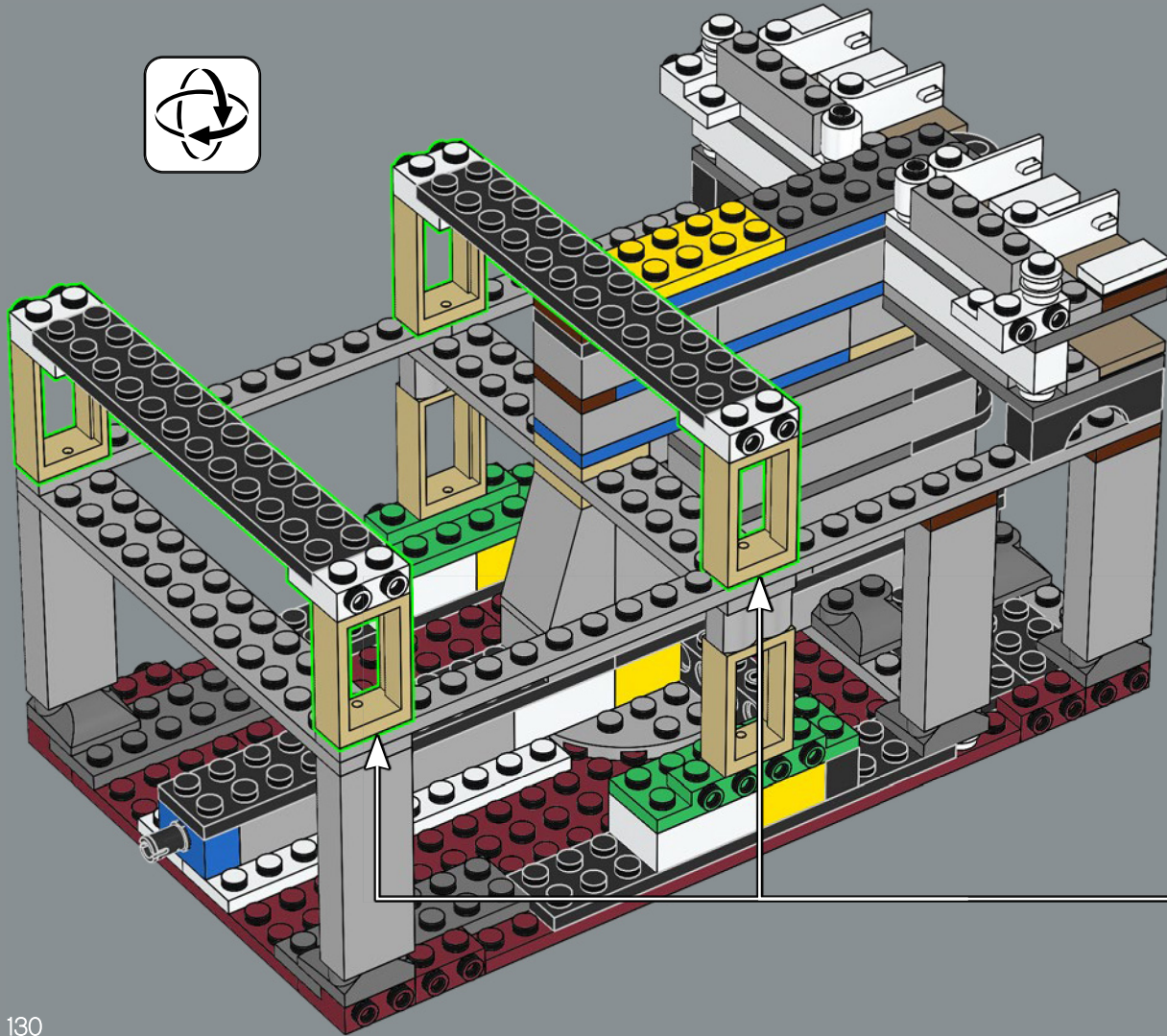

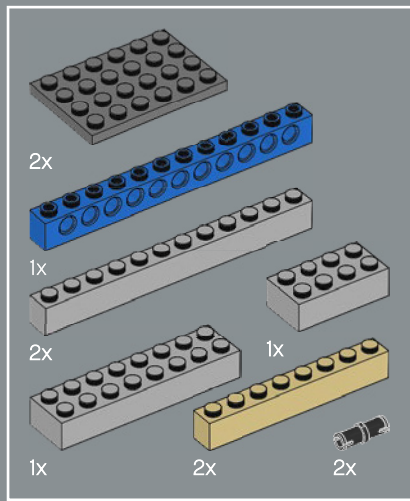

164

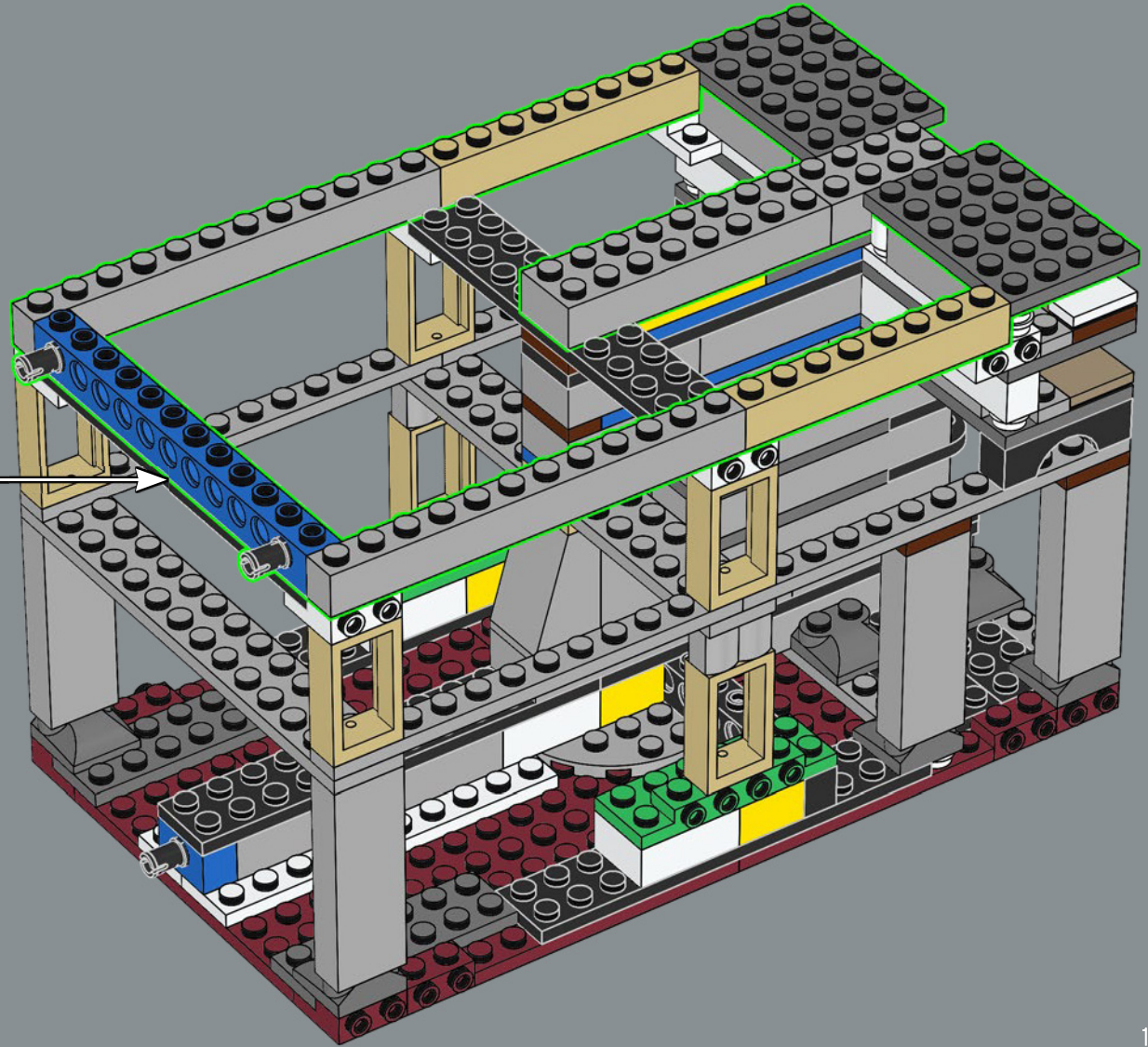
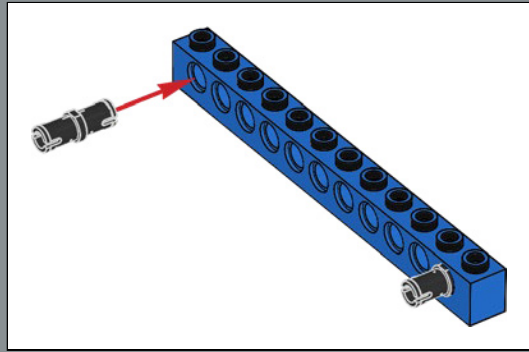

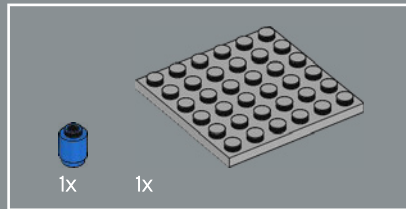
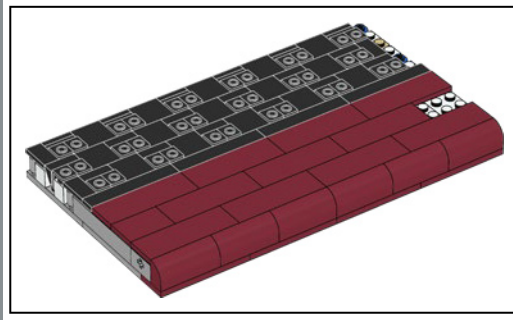
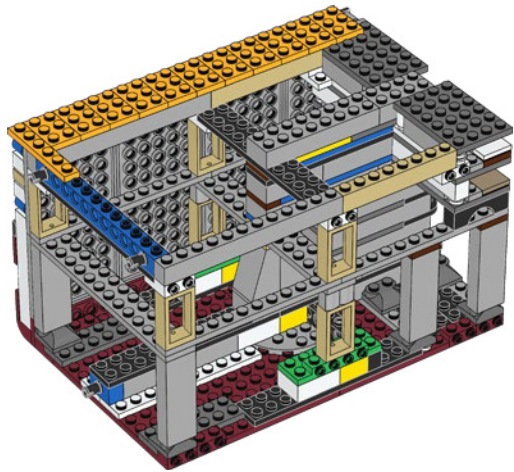
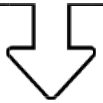

165

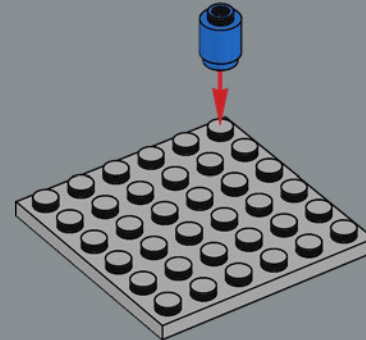

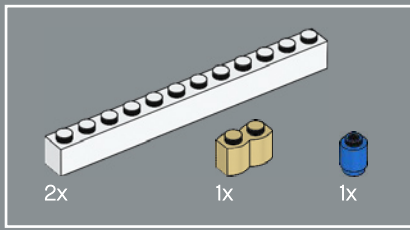

166

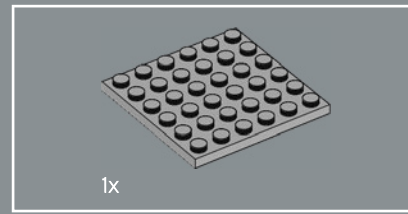
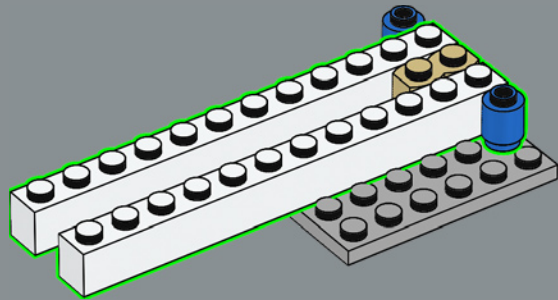

167

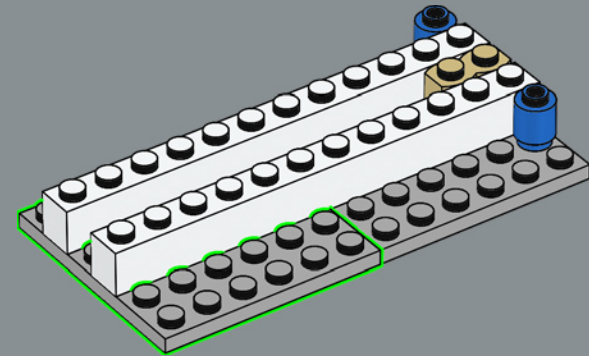

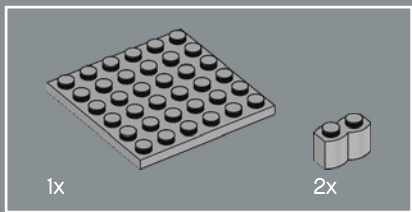

168

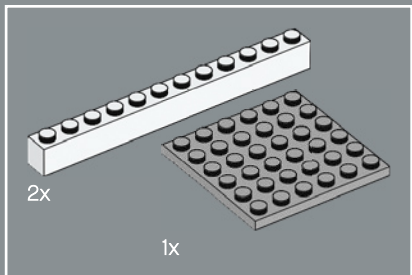
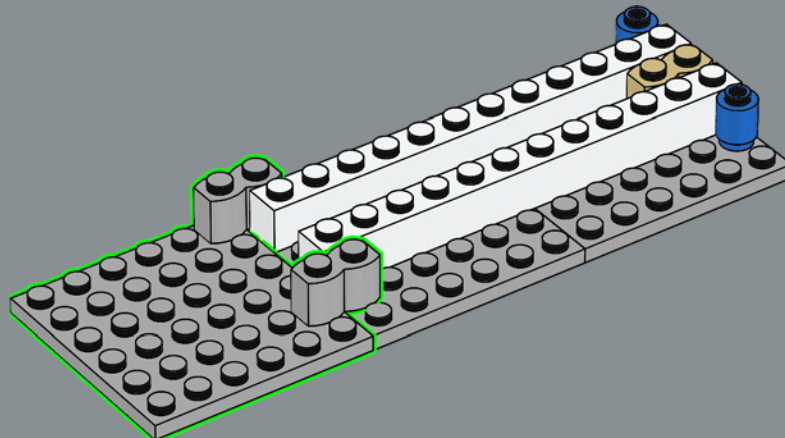

169

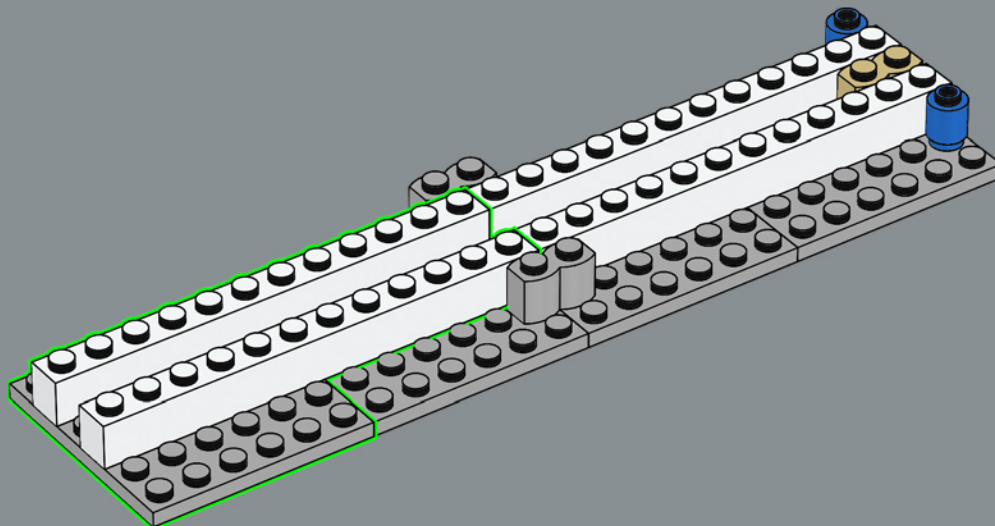



170

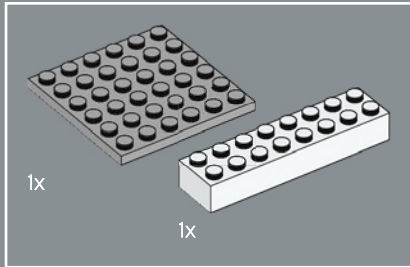
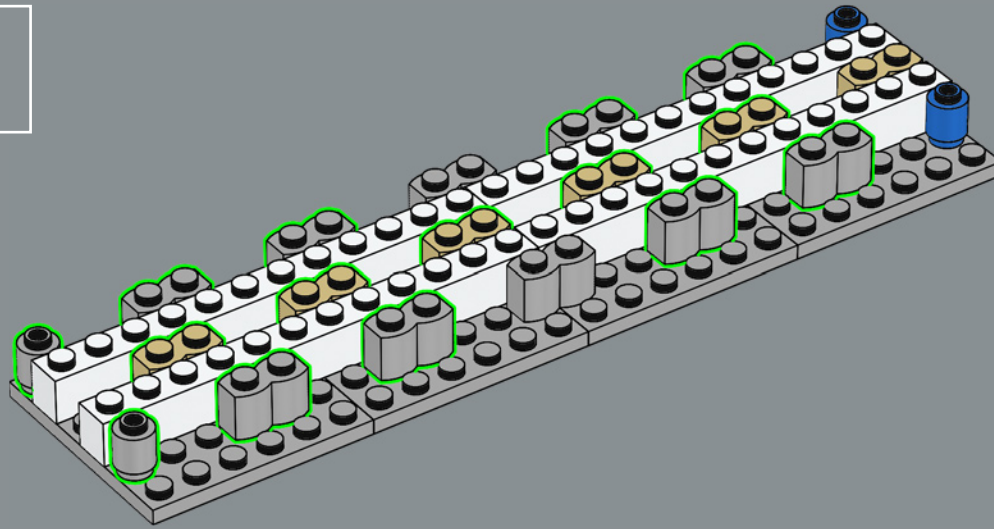

171

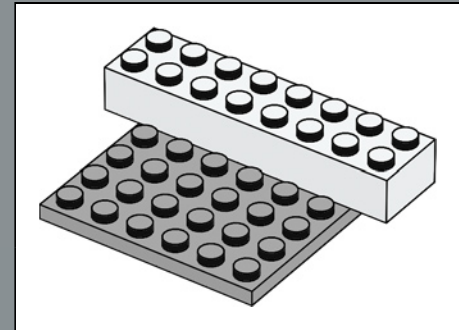
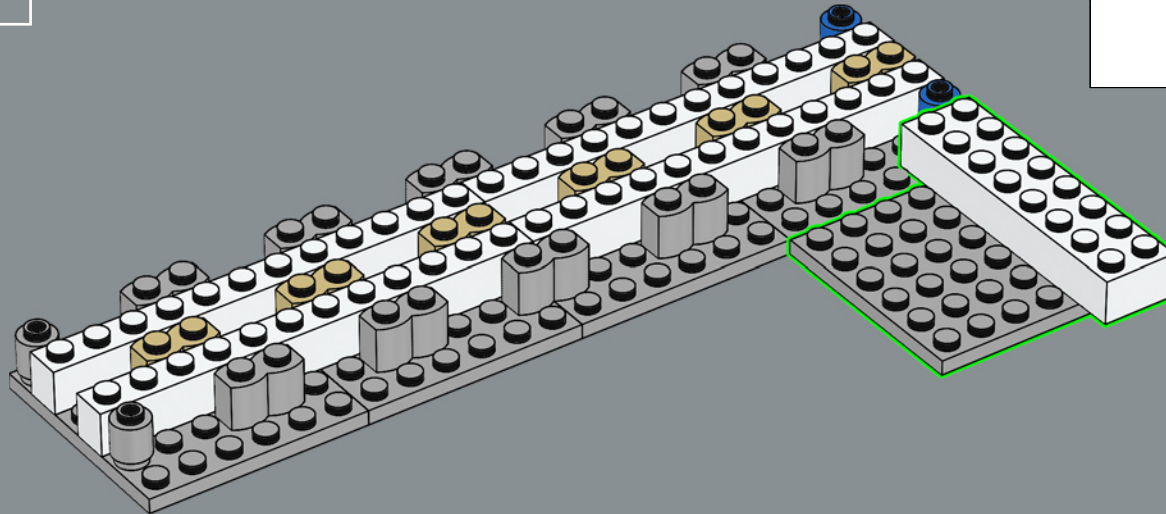

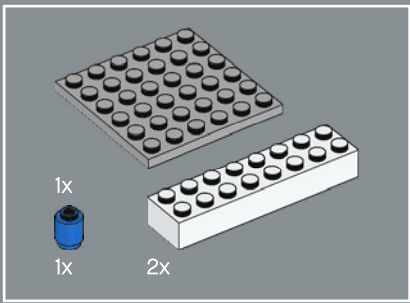

172

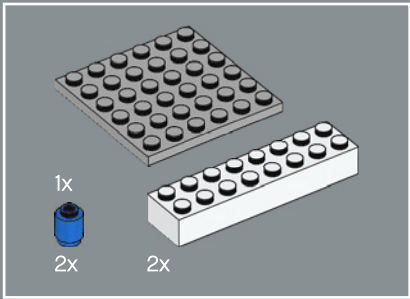
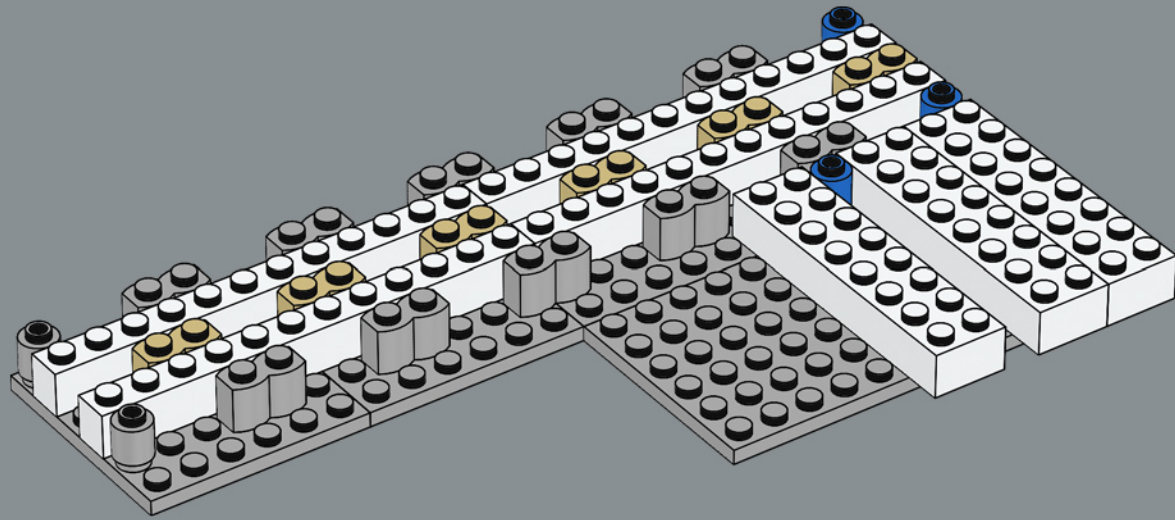

173

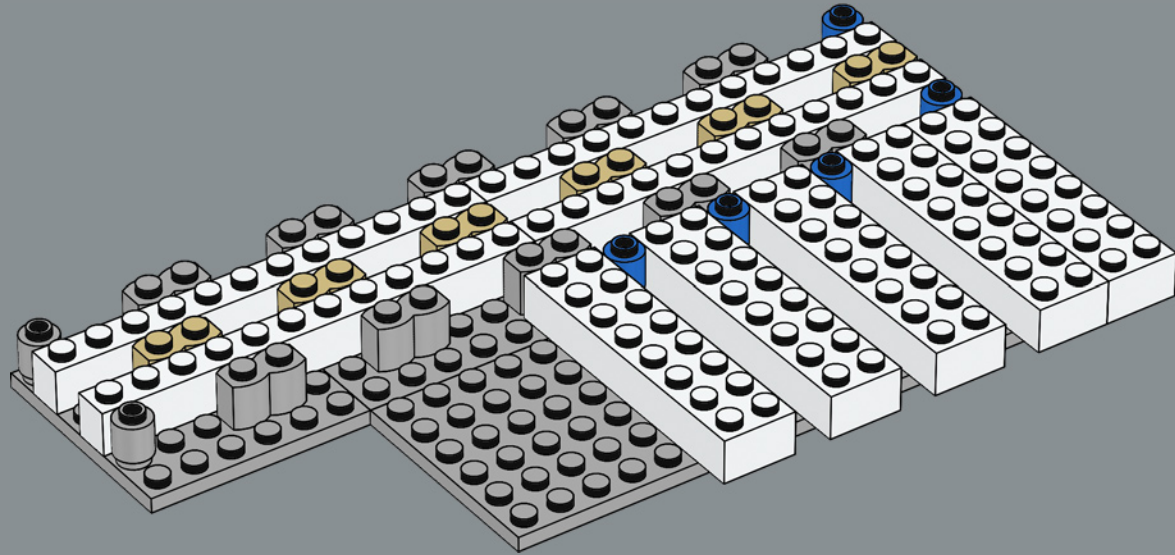

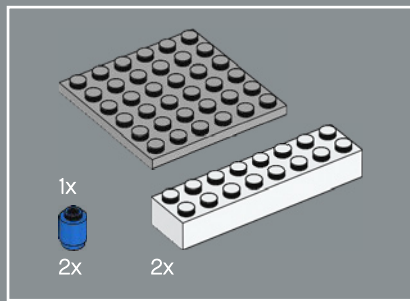

174

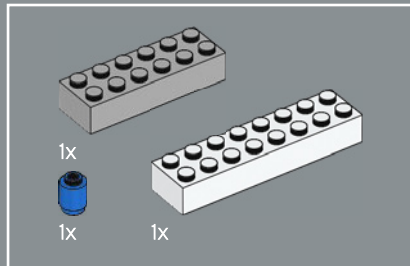
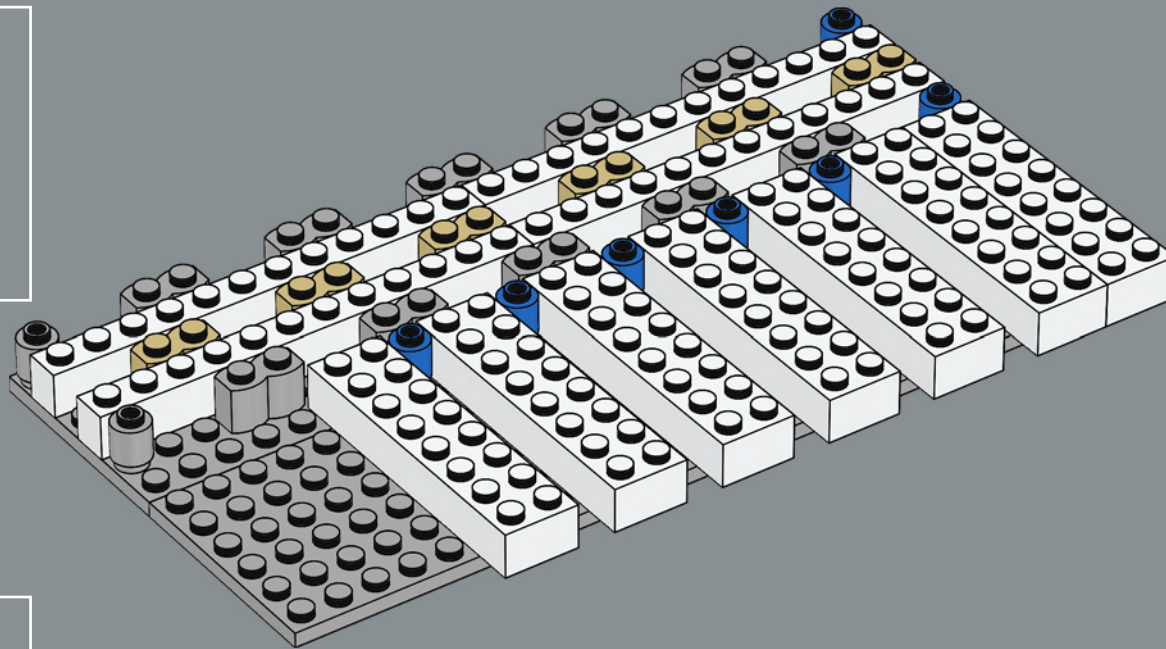

175



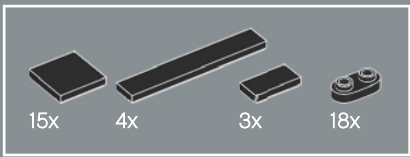

176

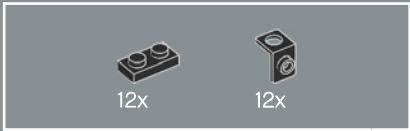
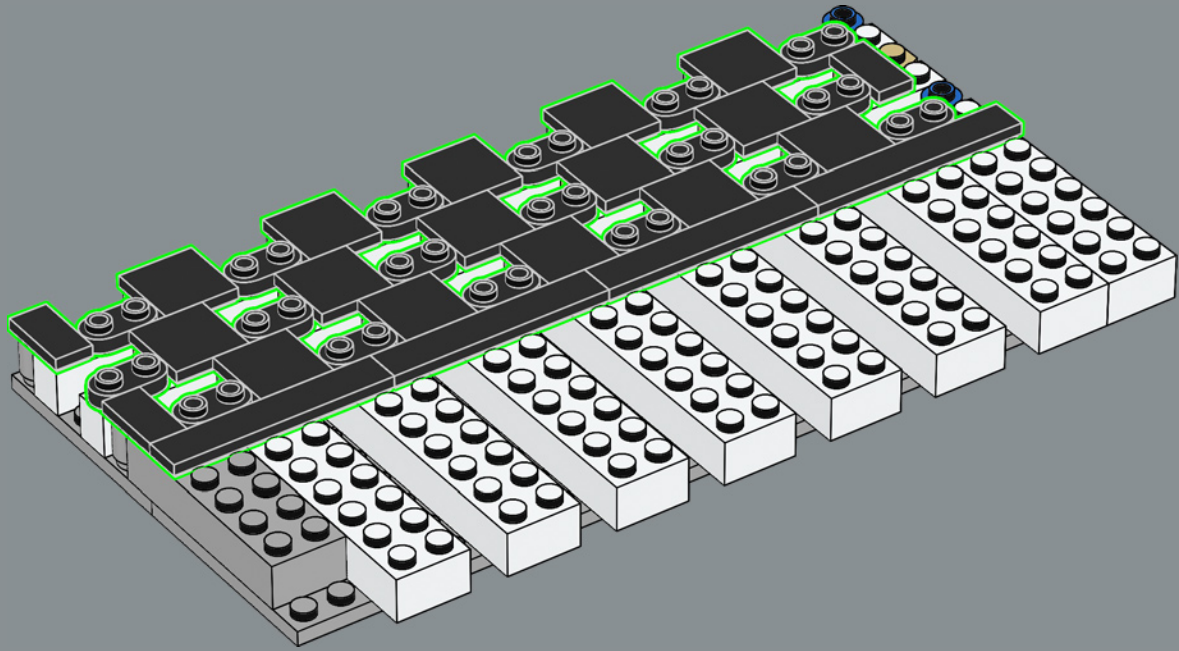

177

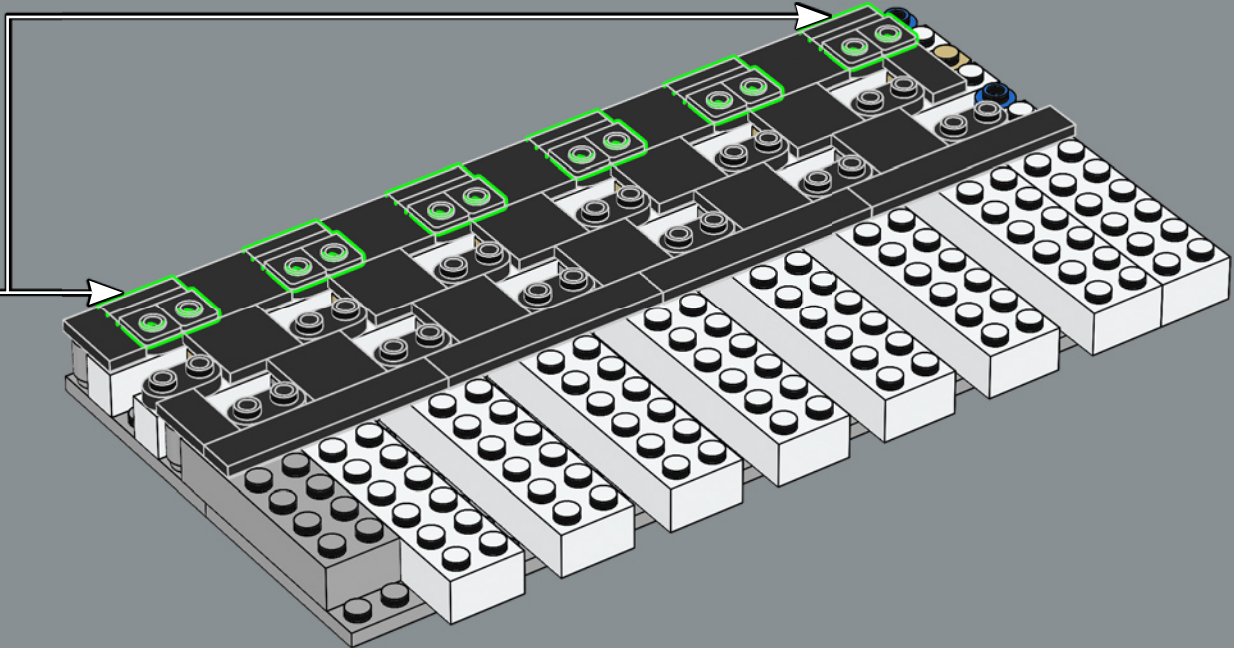
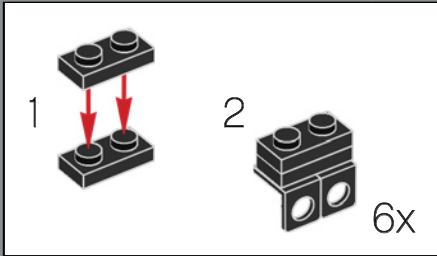



178

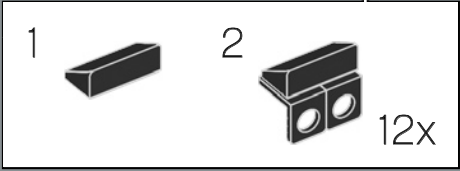
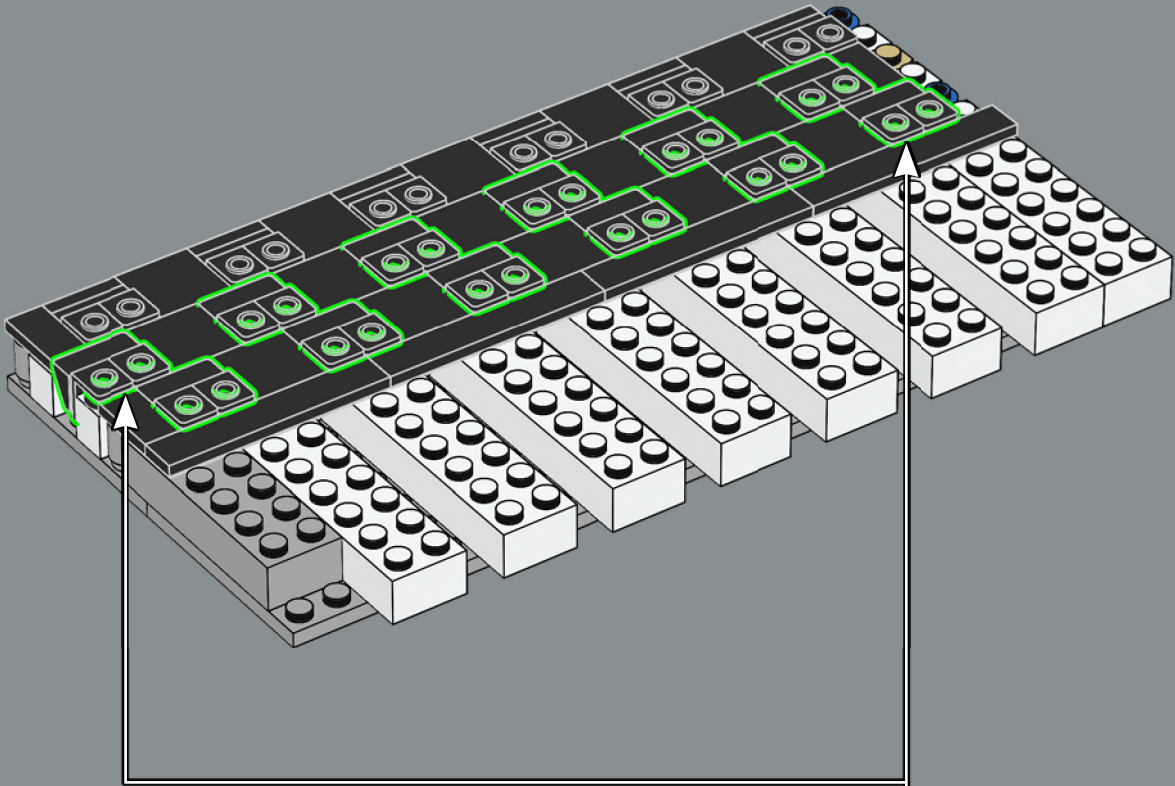

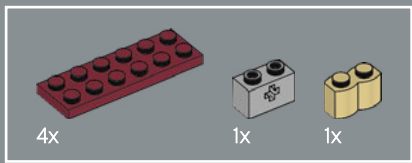

179

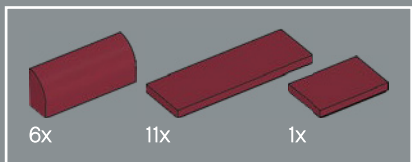
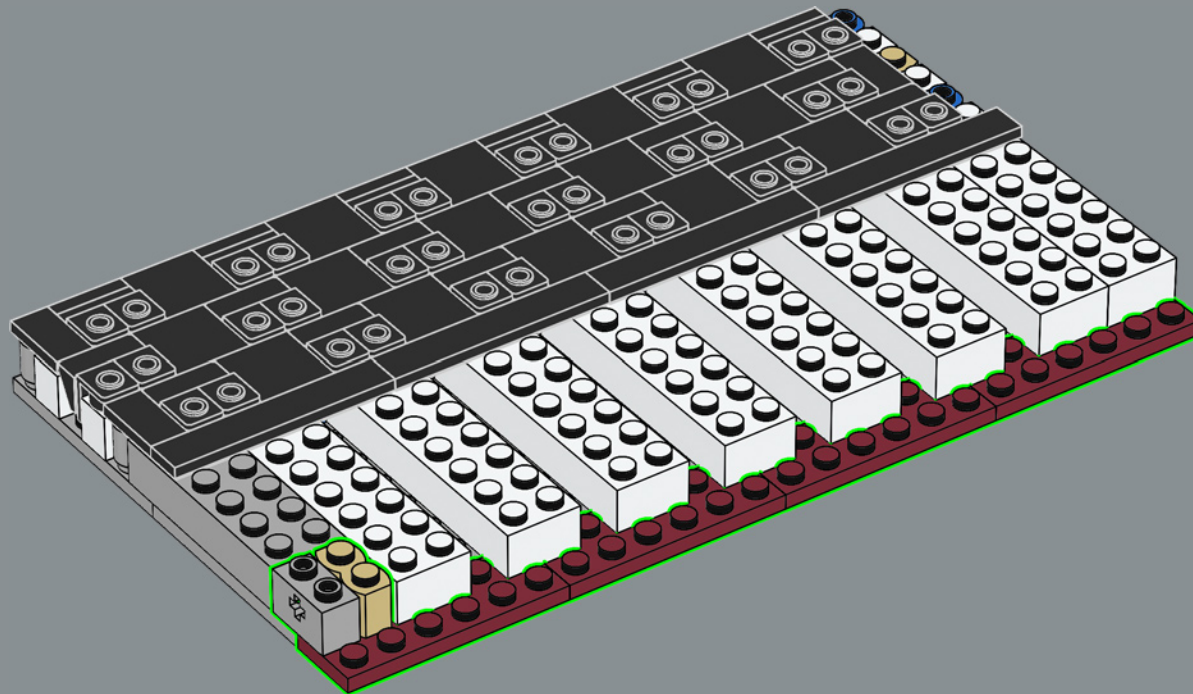

180

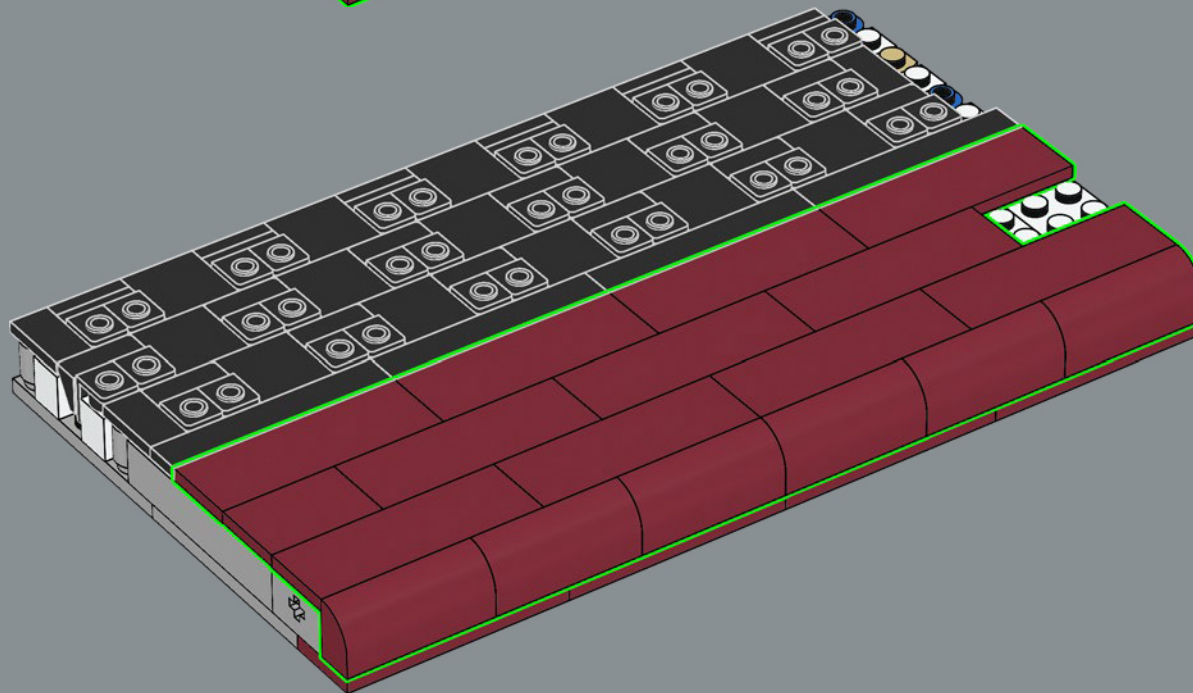

La coque du navire est maintenue par plus de 3 millions de rivets en fer et en acier pesant plus de 1 200 tonnes.

181

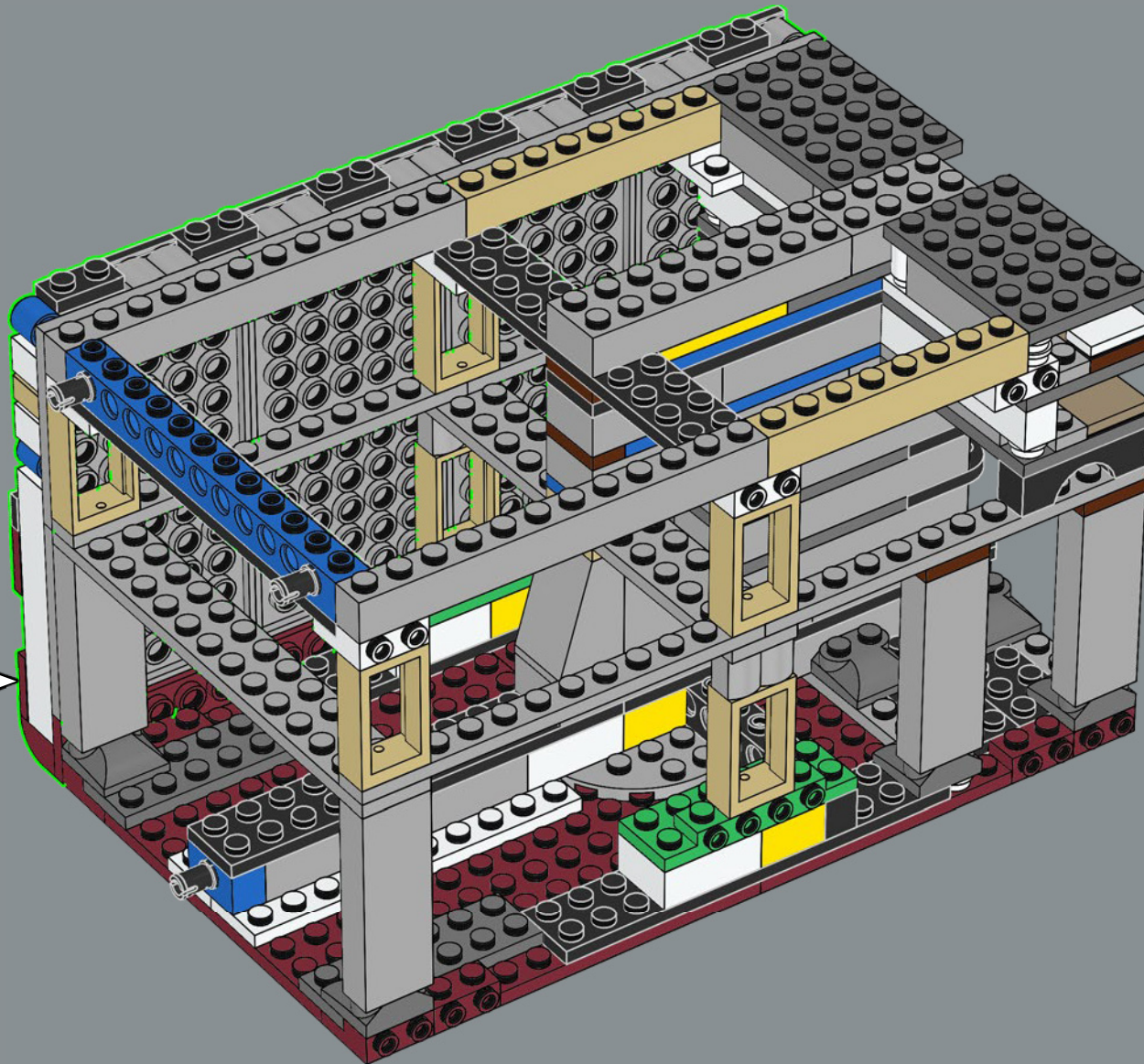

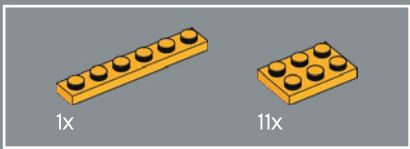

182

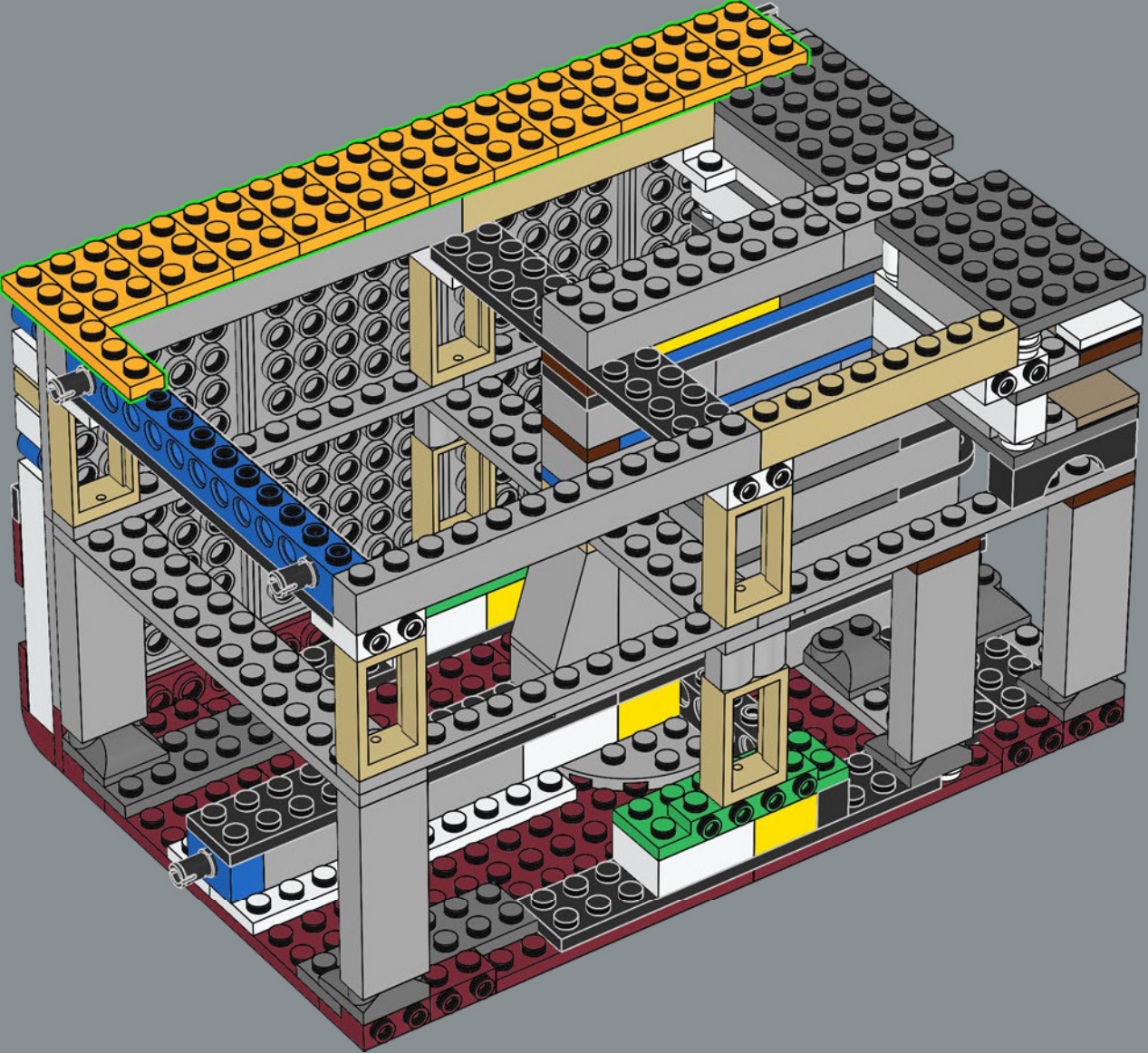

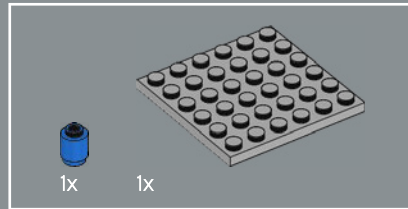
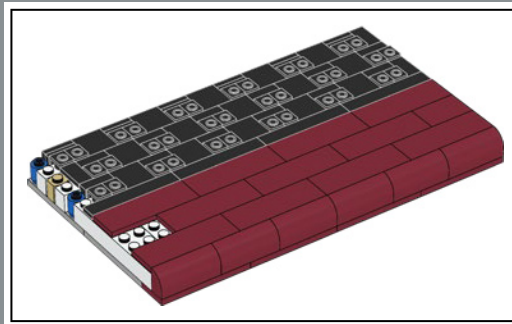
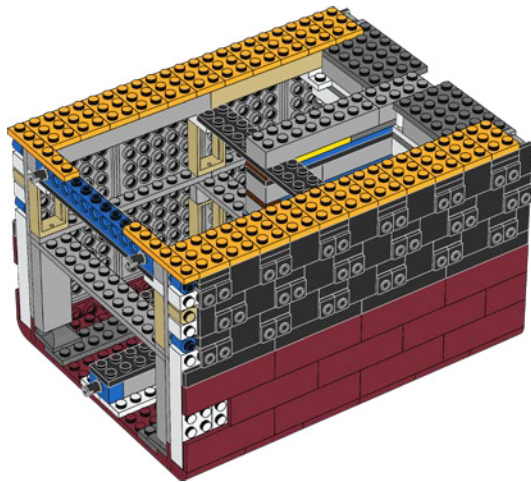
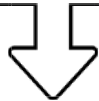

183

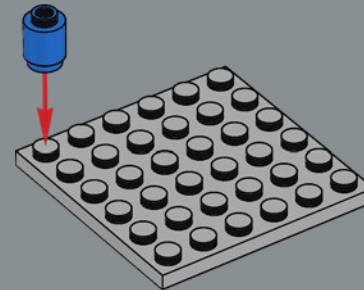

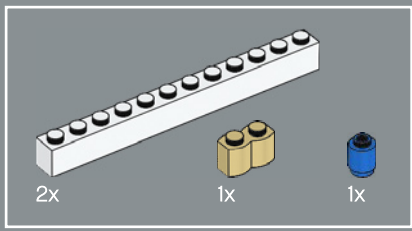

184

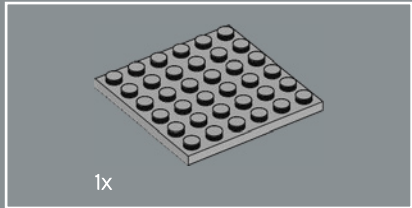
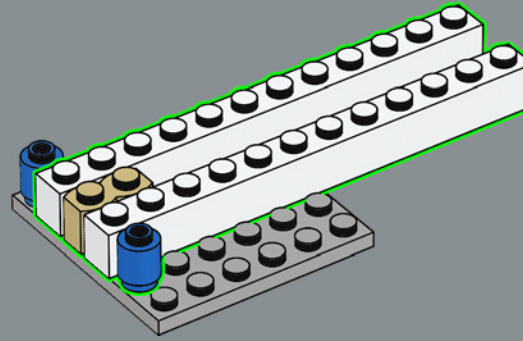

185

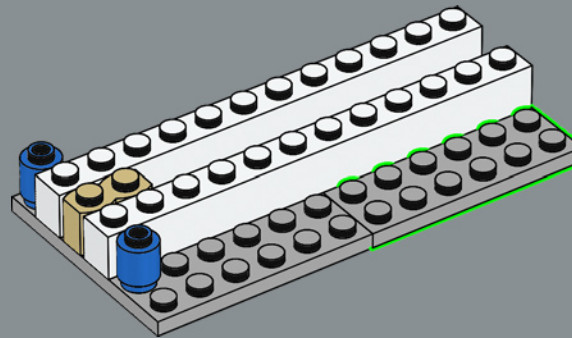

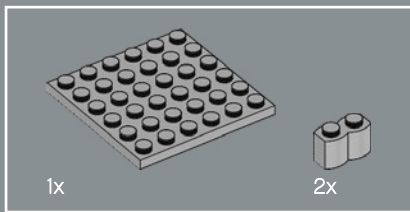

186

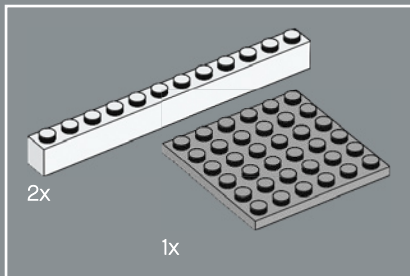
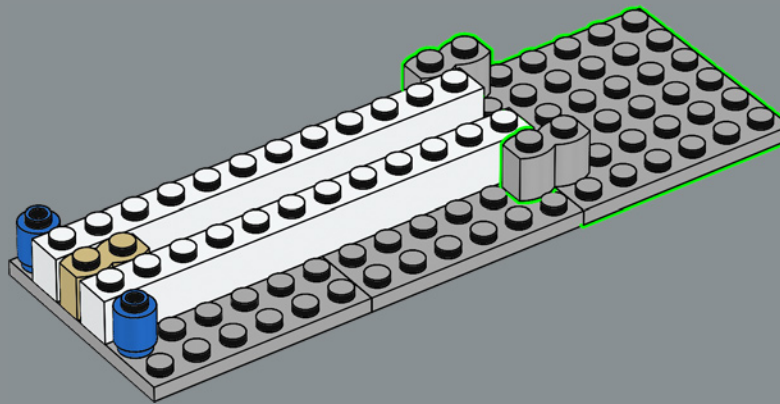

187

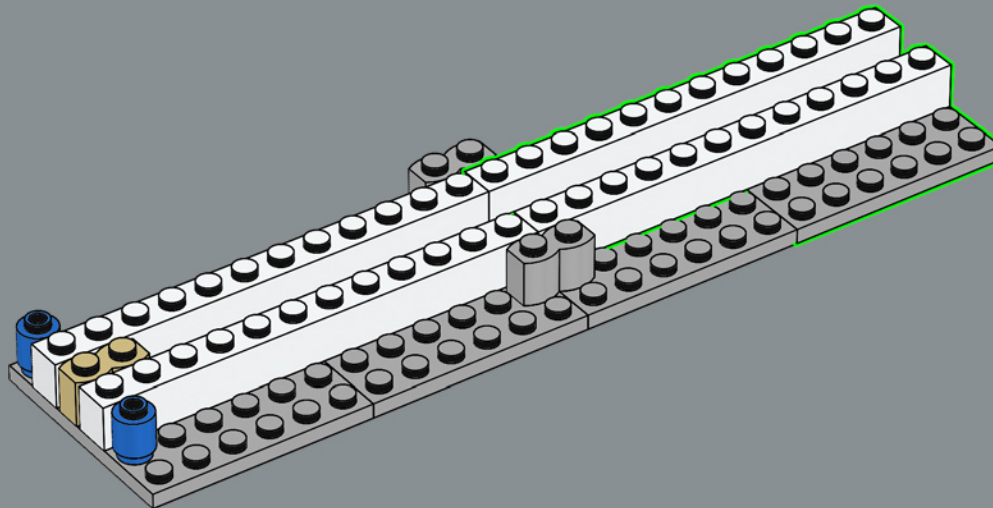



188

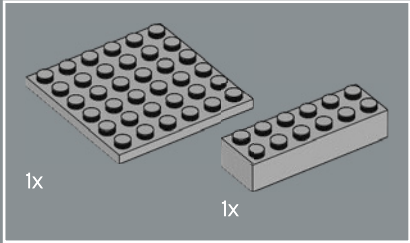
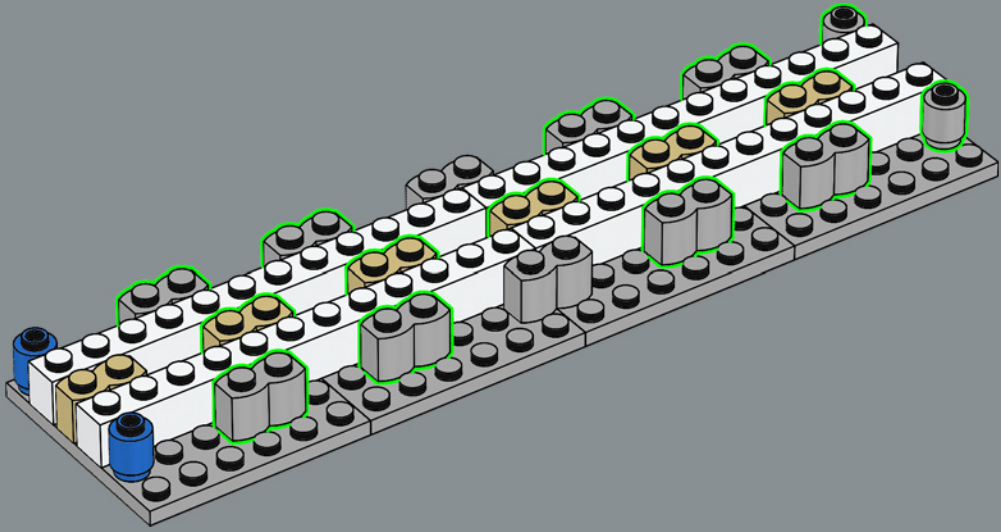

189

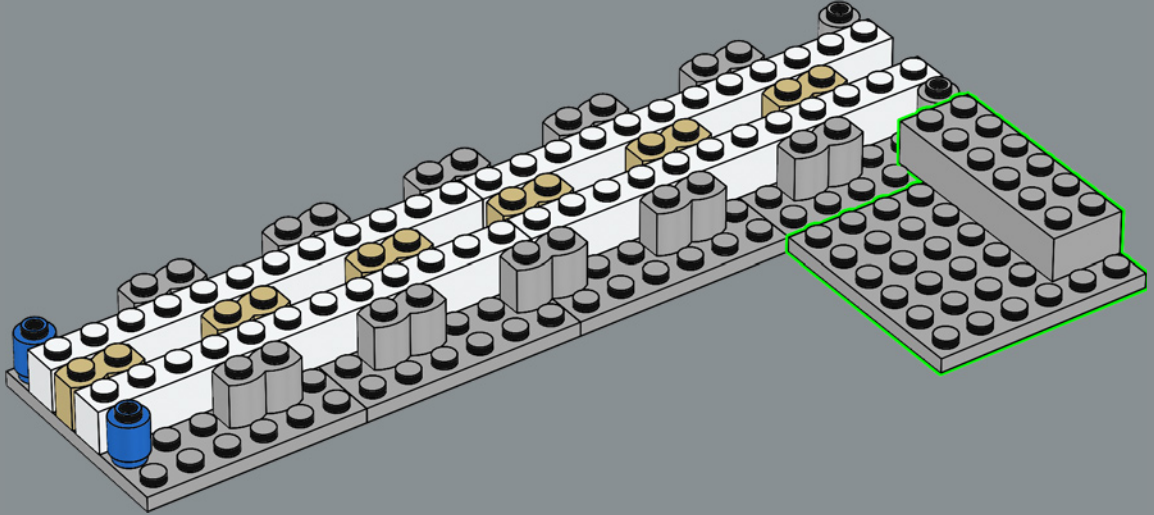

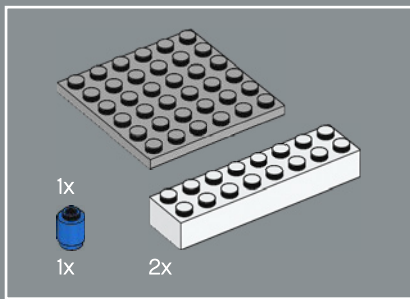

190

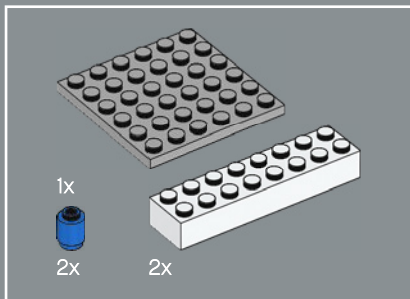
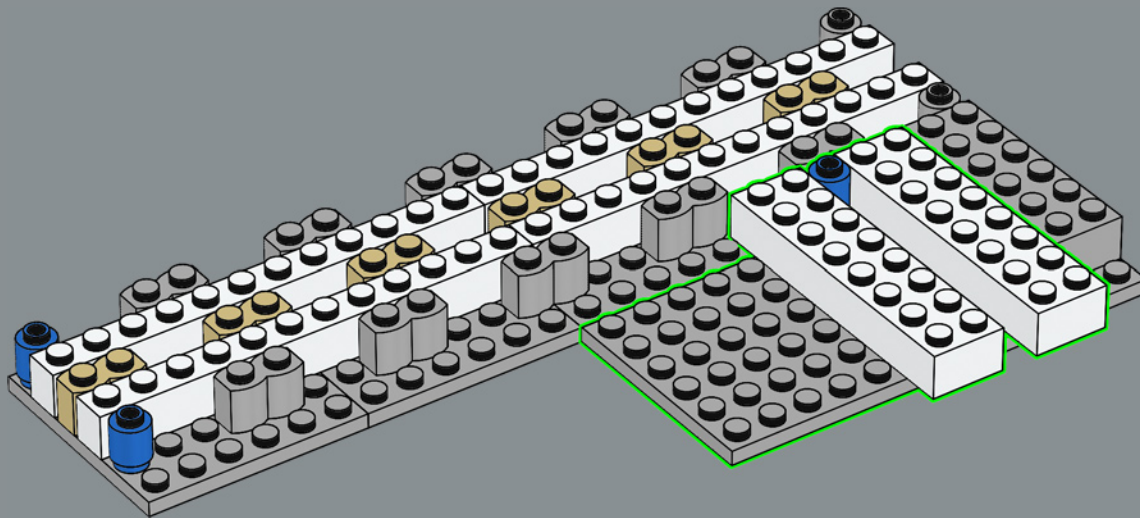

191

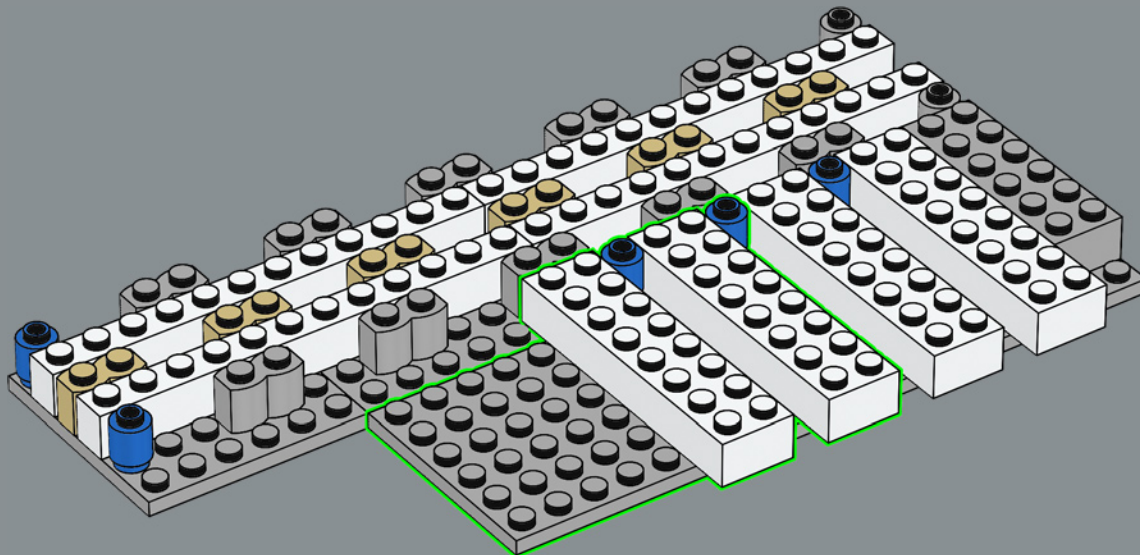

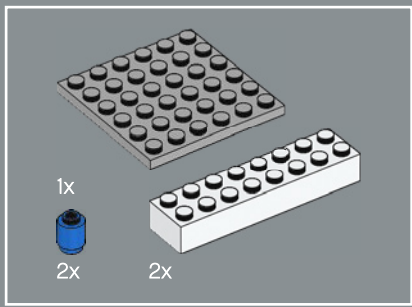

192

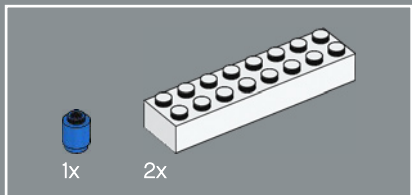
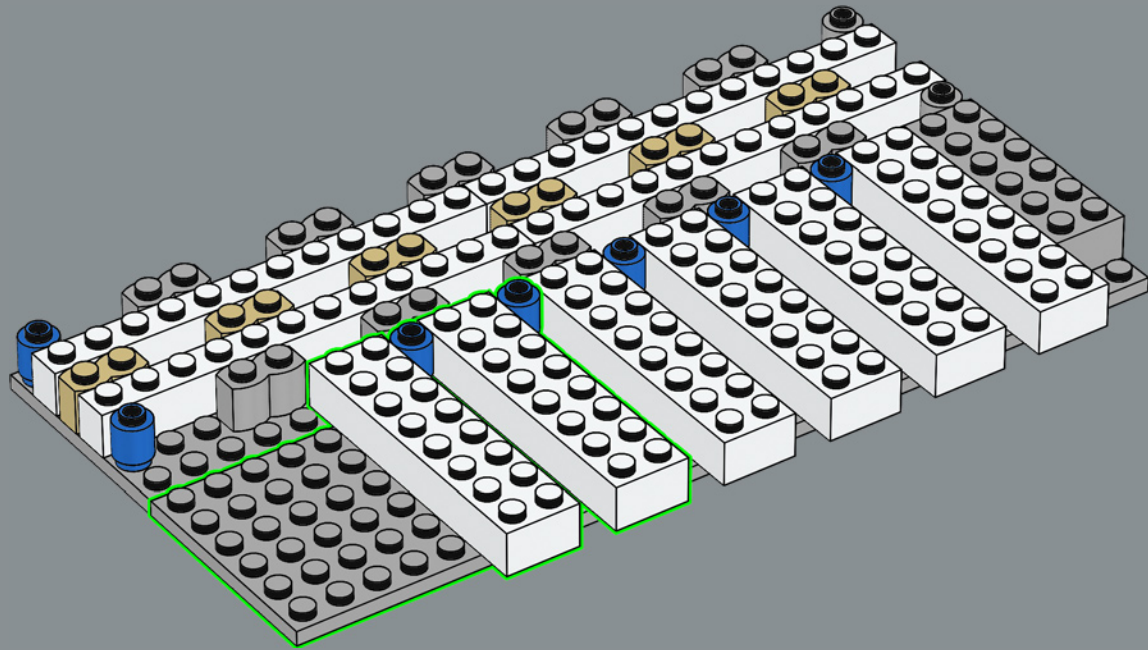

193

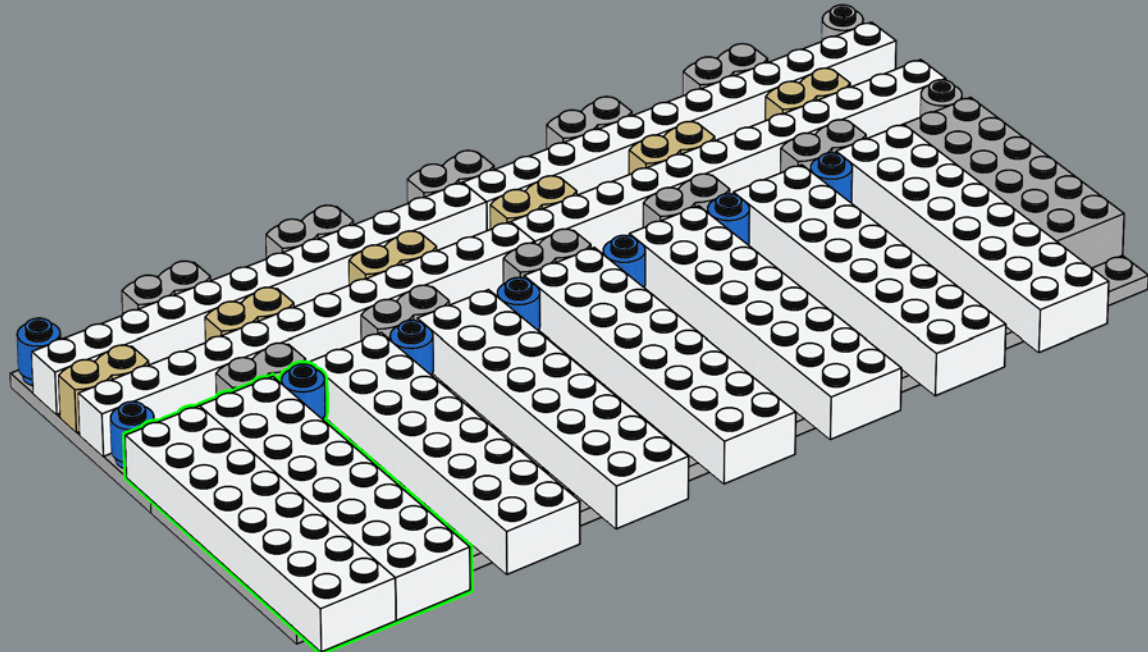

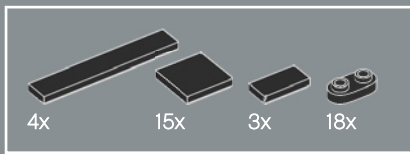

194

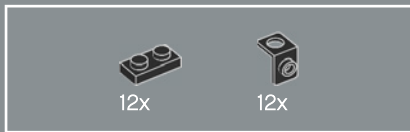
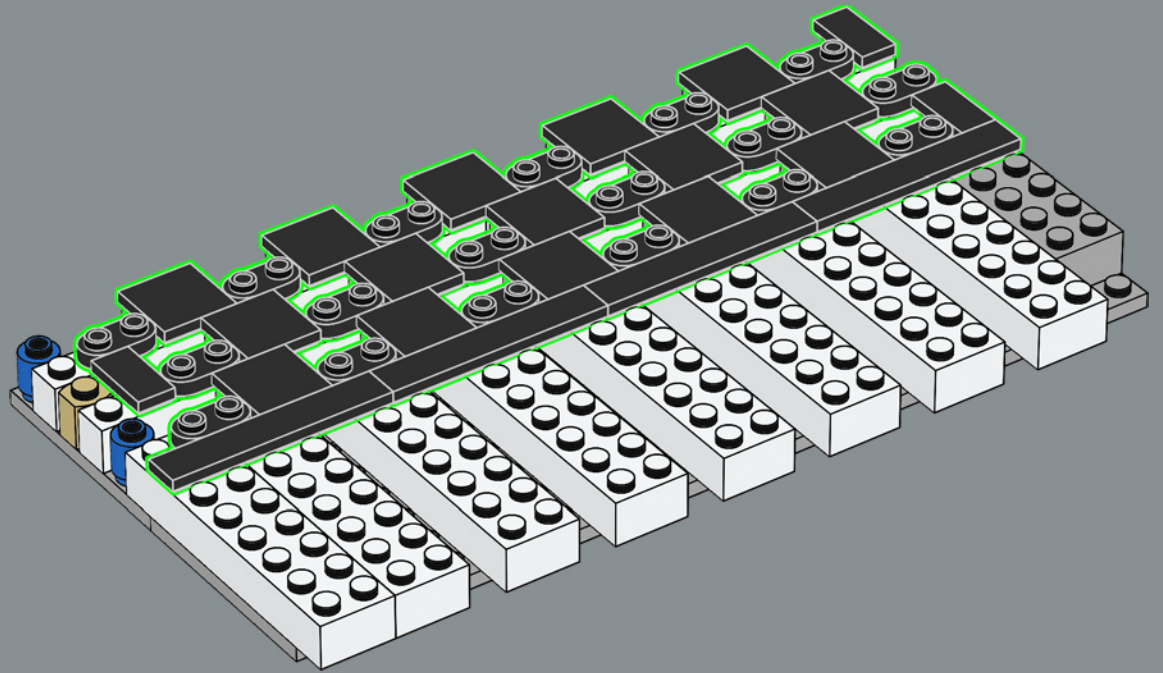

195

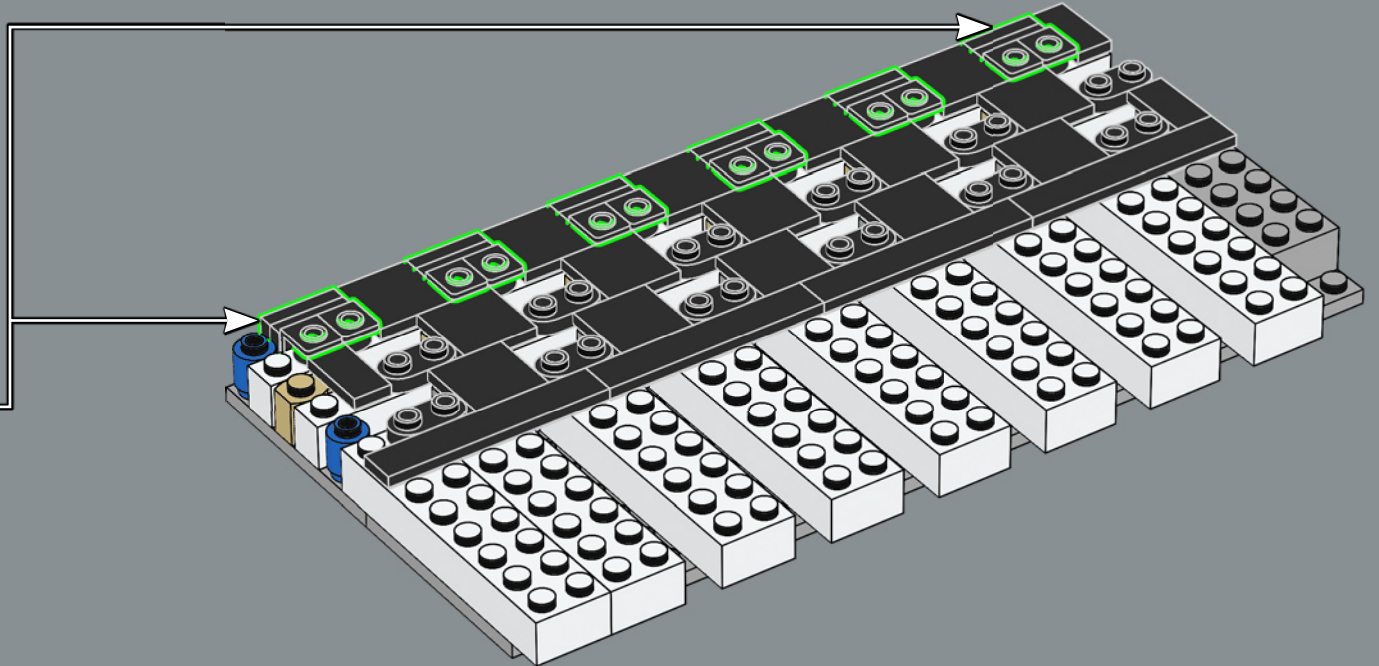
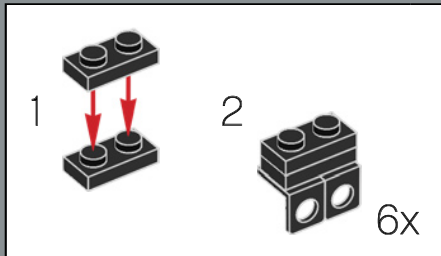

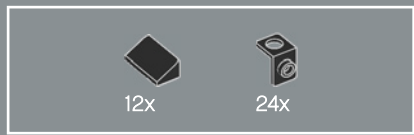

196

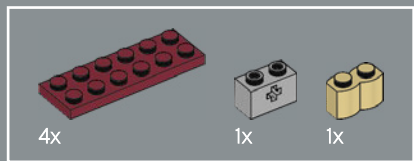
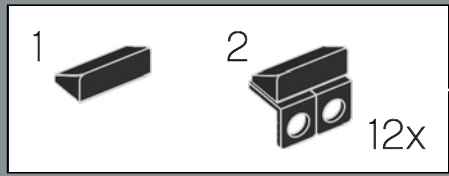
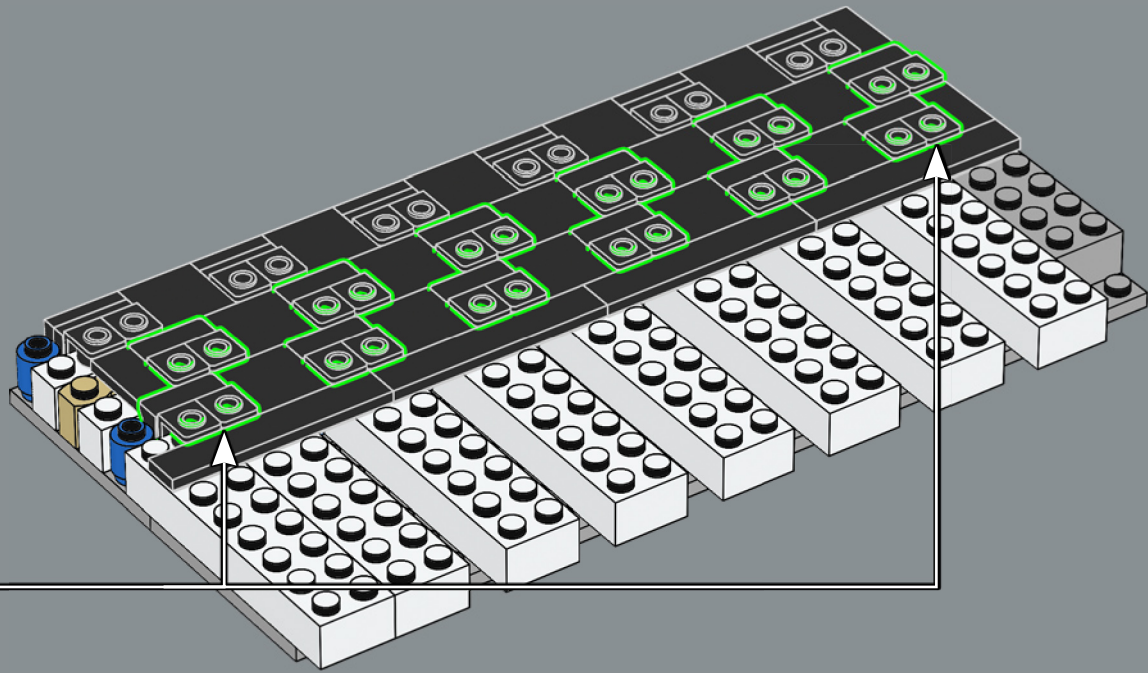

197

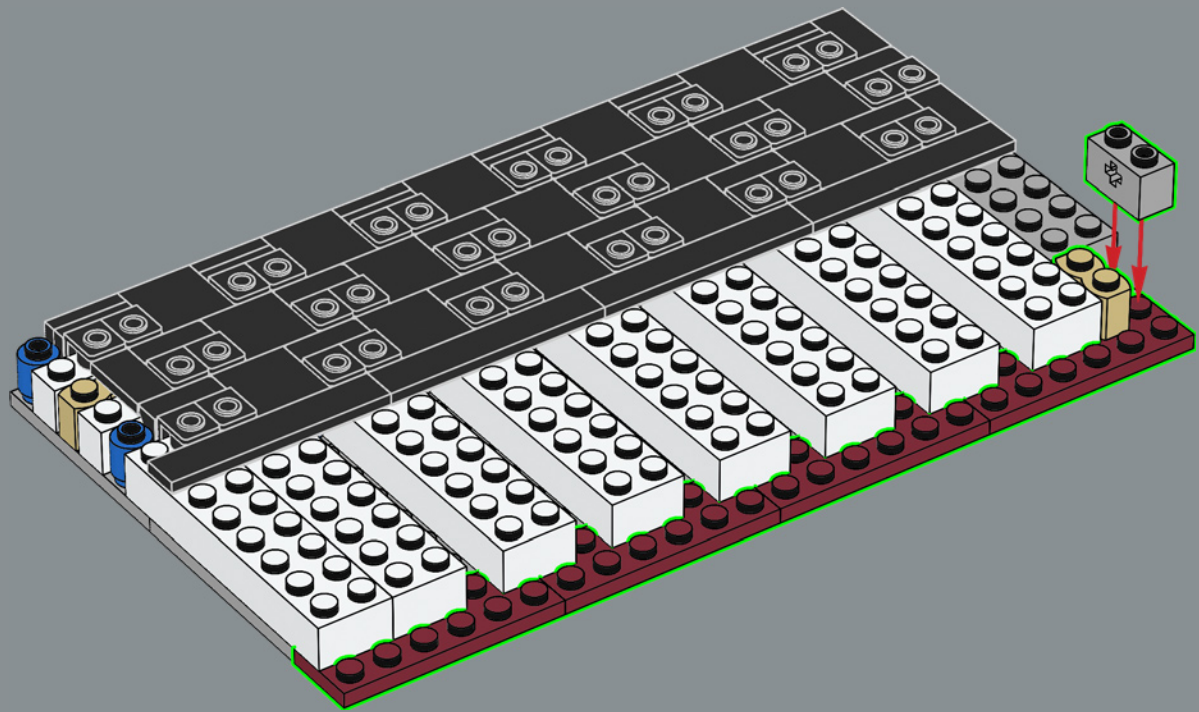

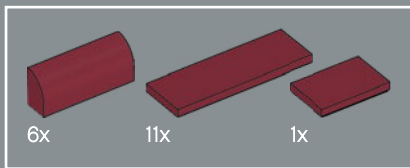

198

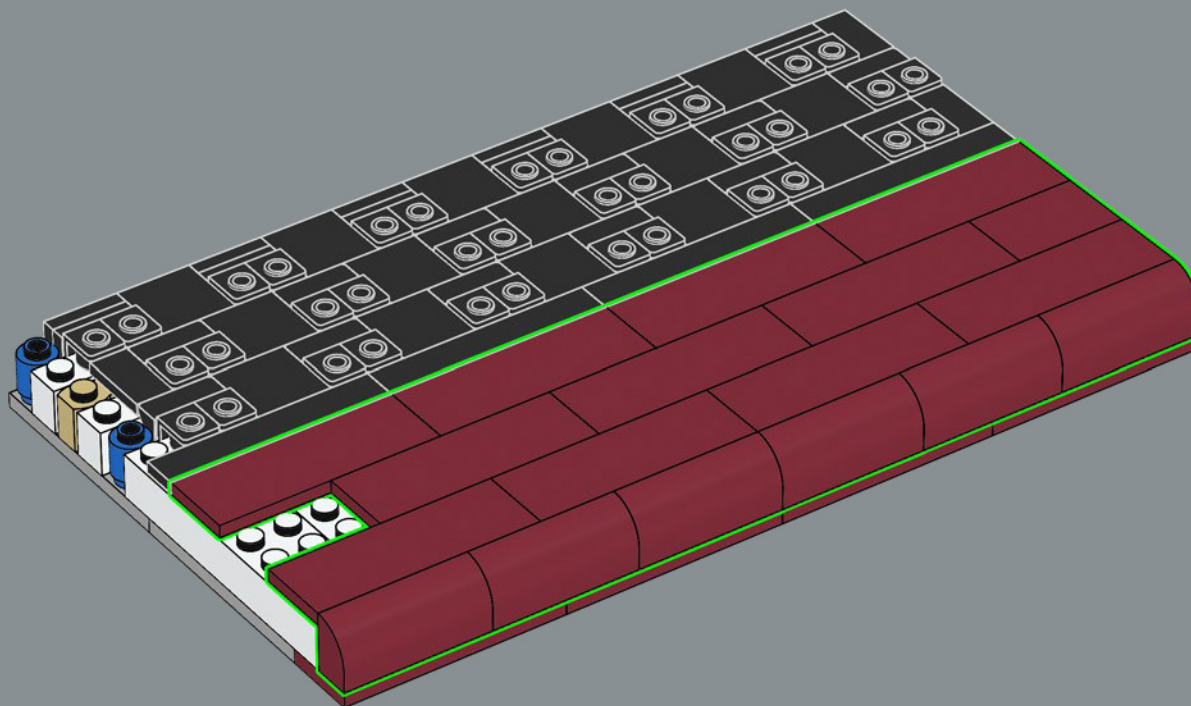

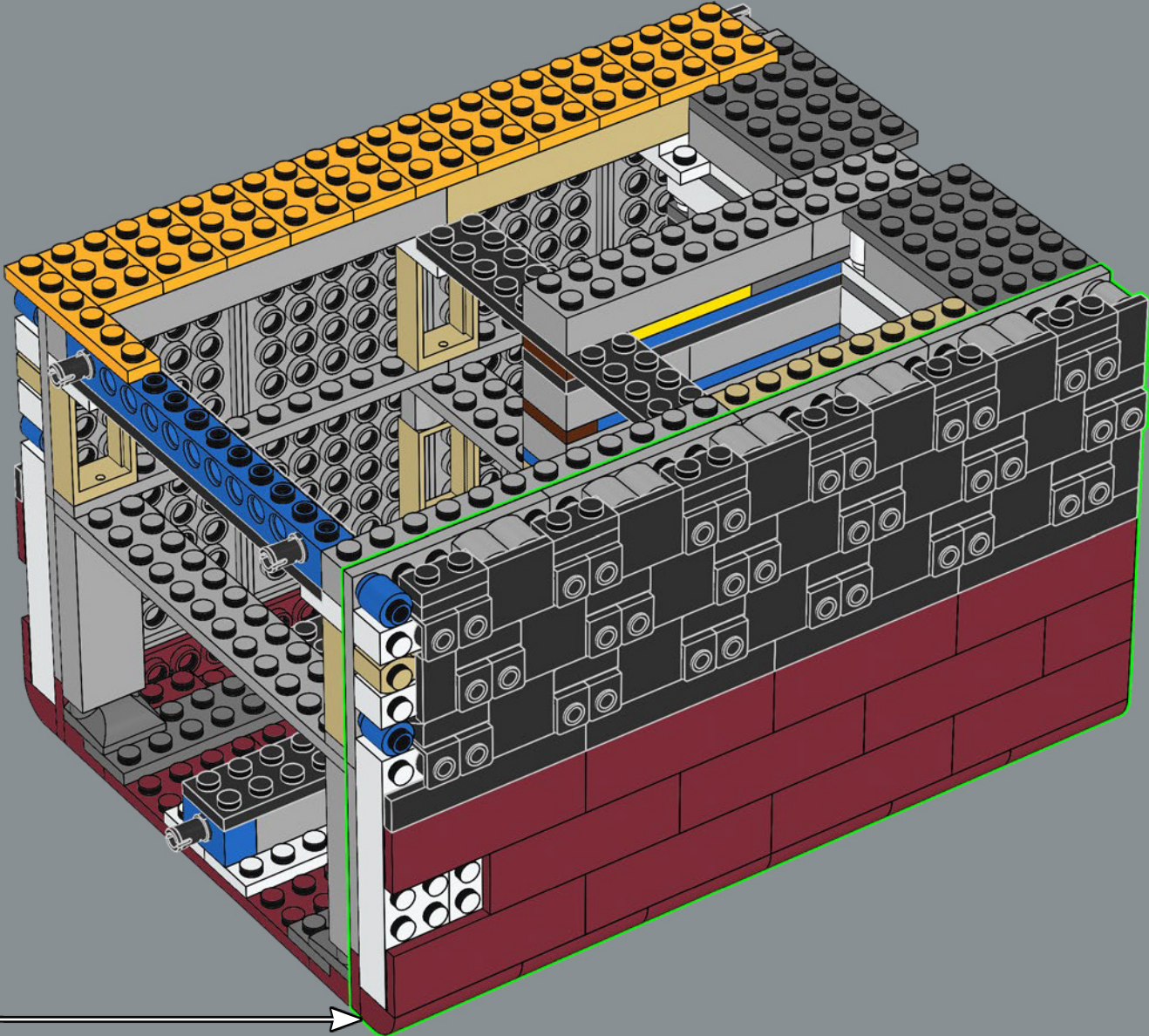

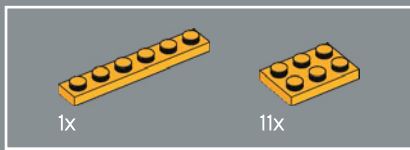

200

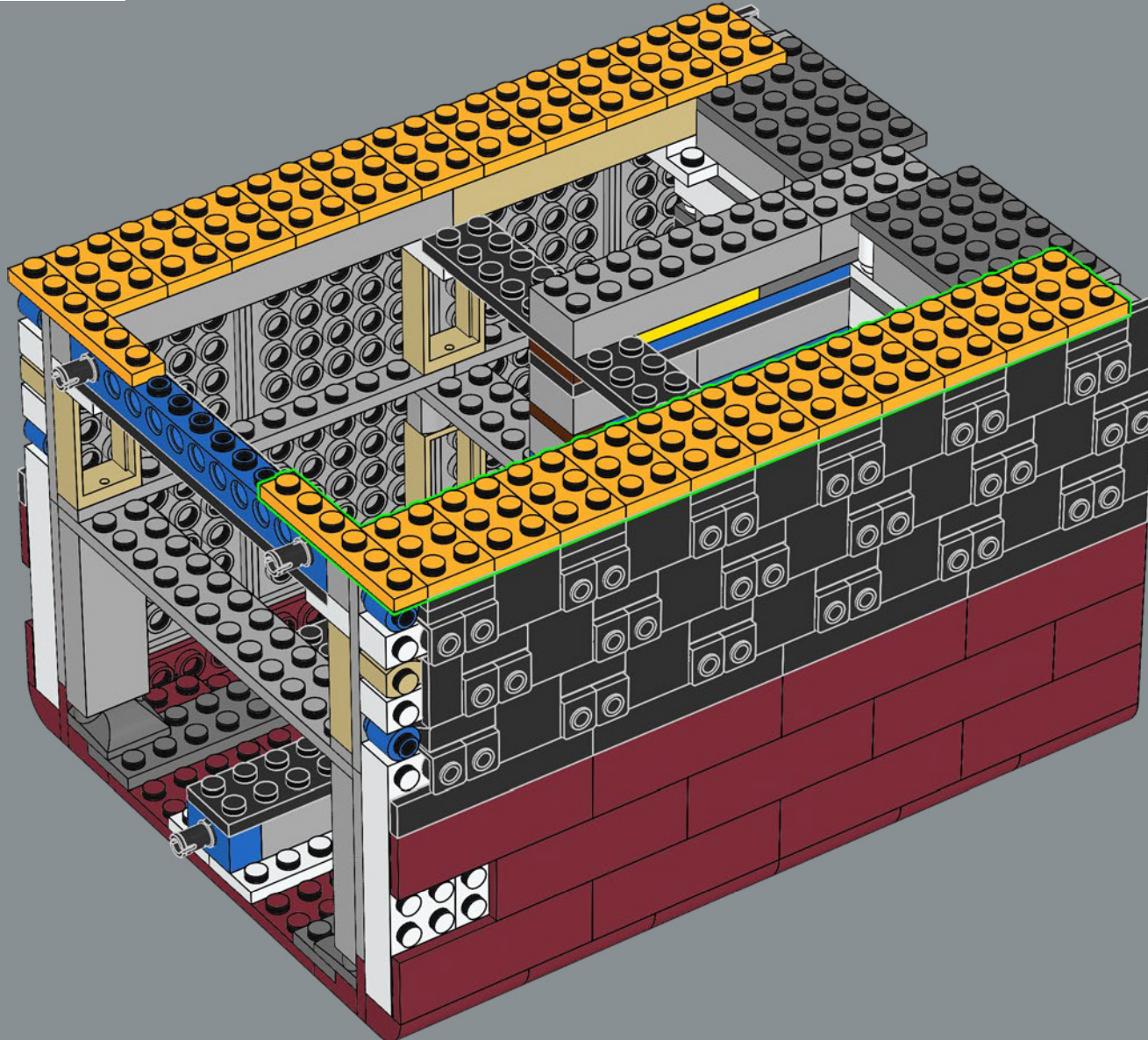

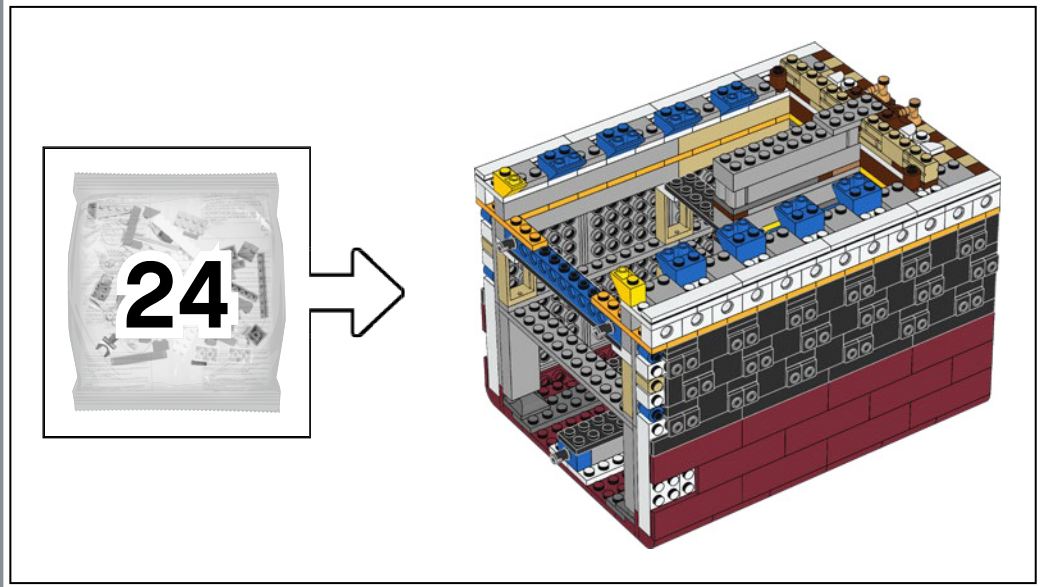

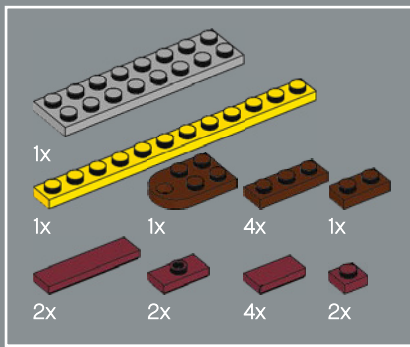

201

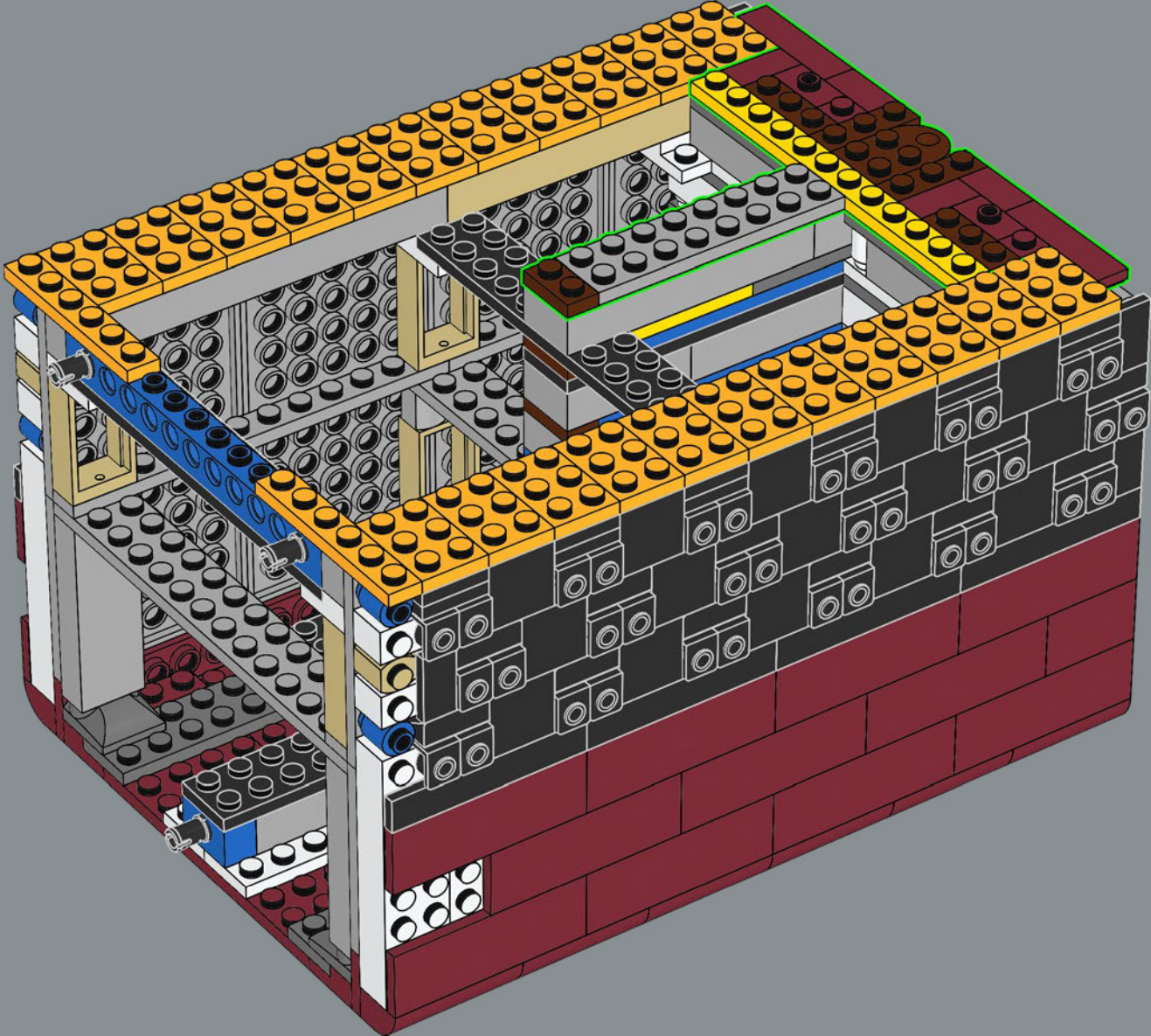

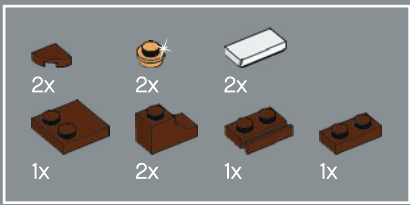

202

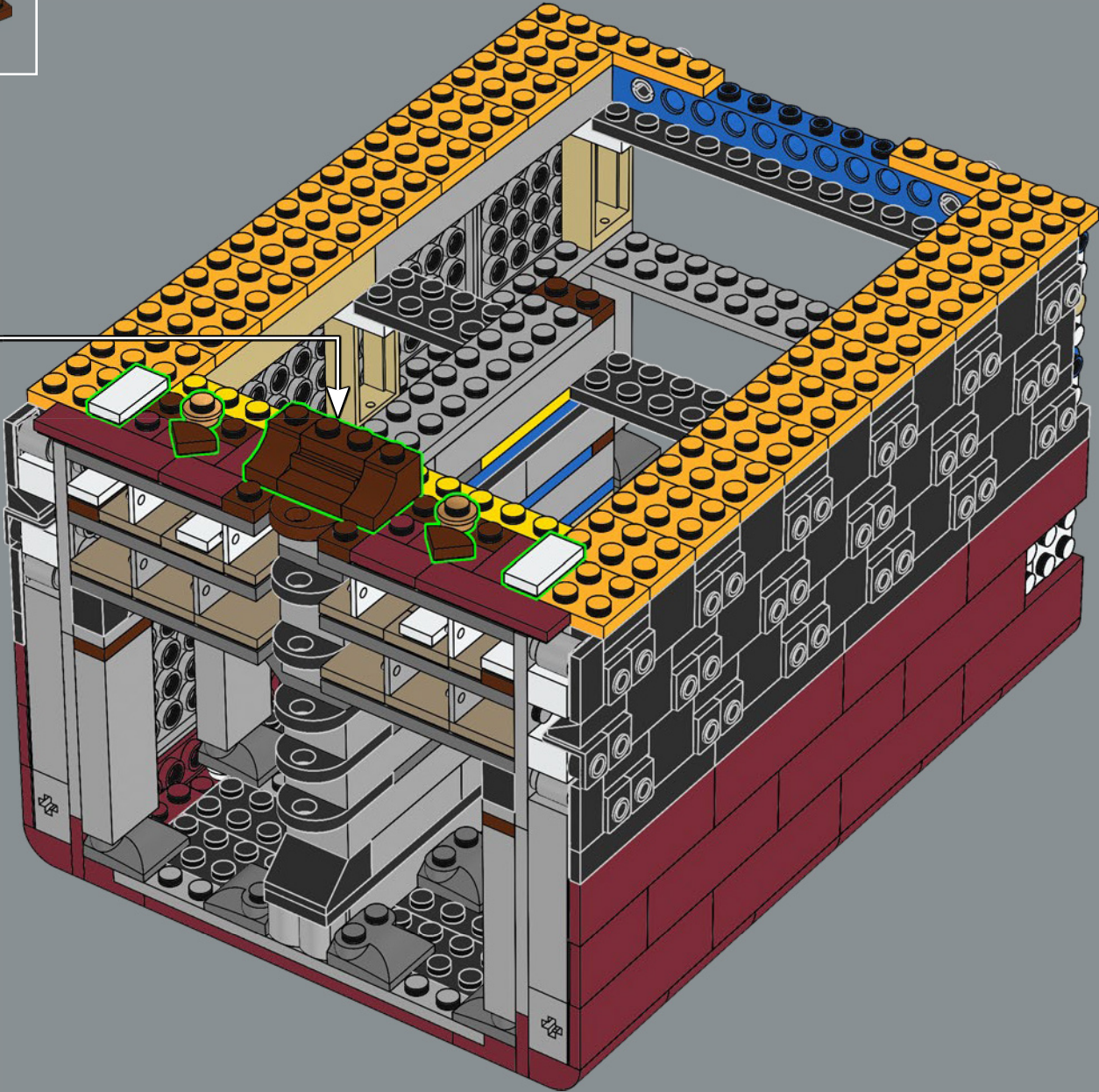
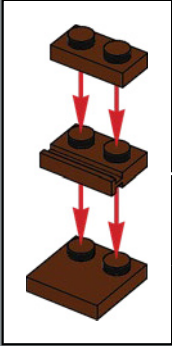

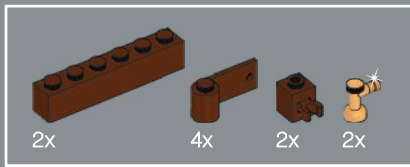

203

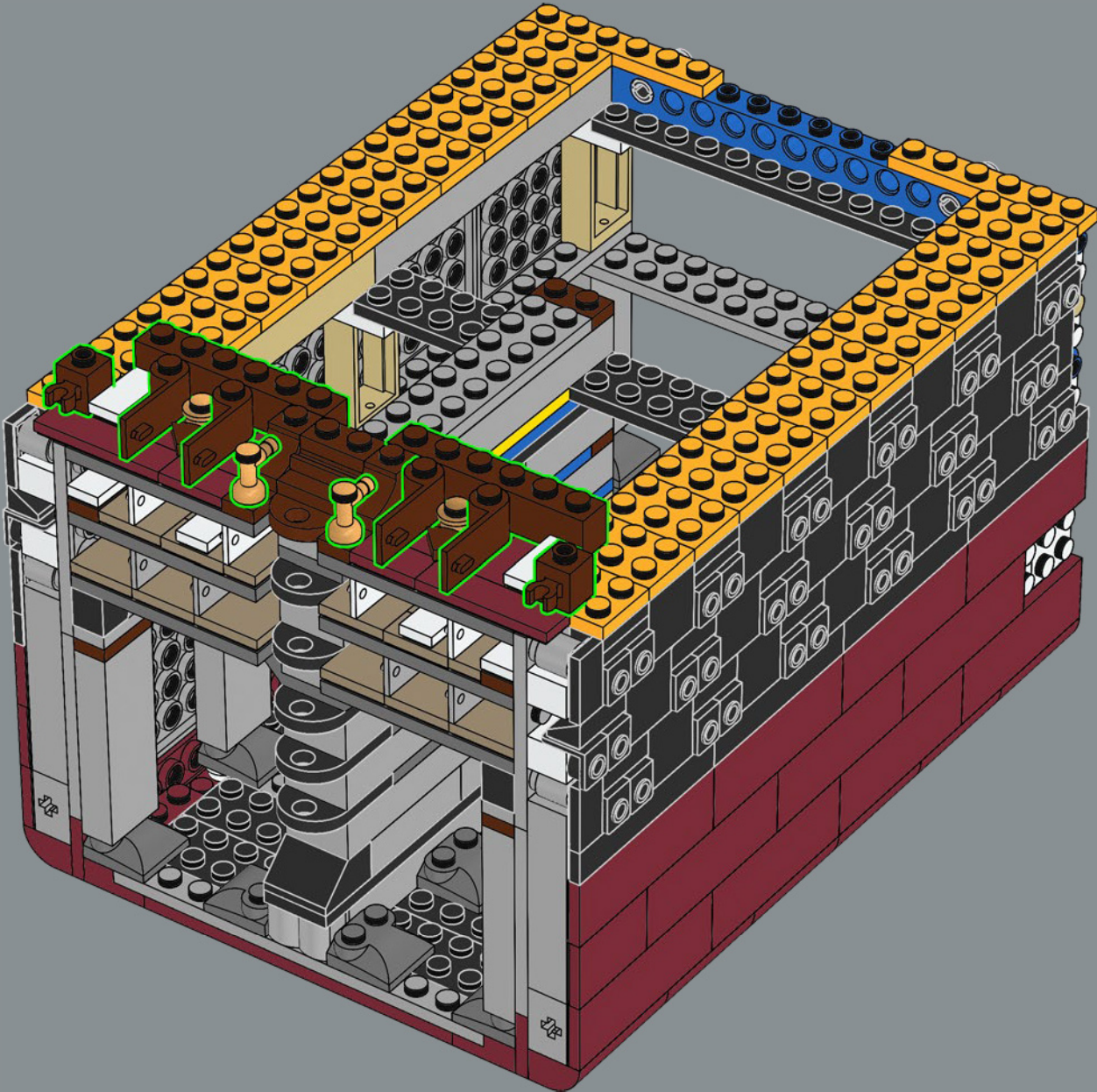

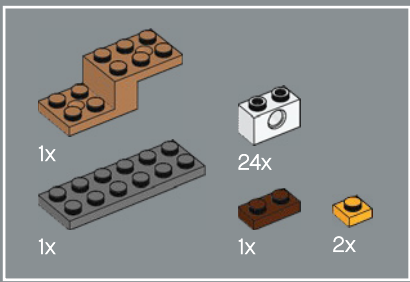

204

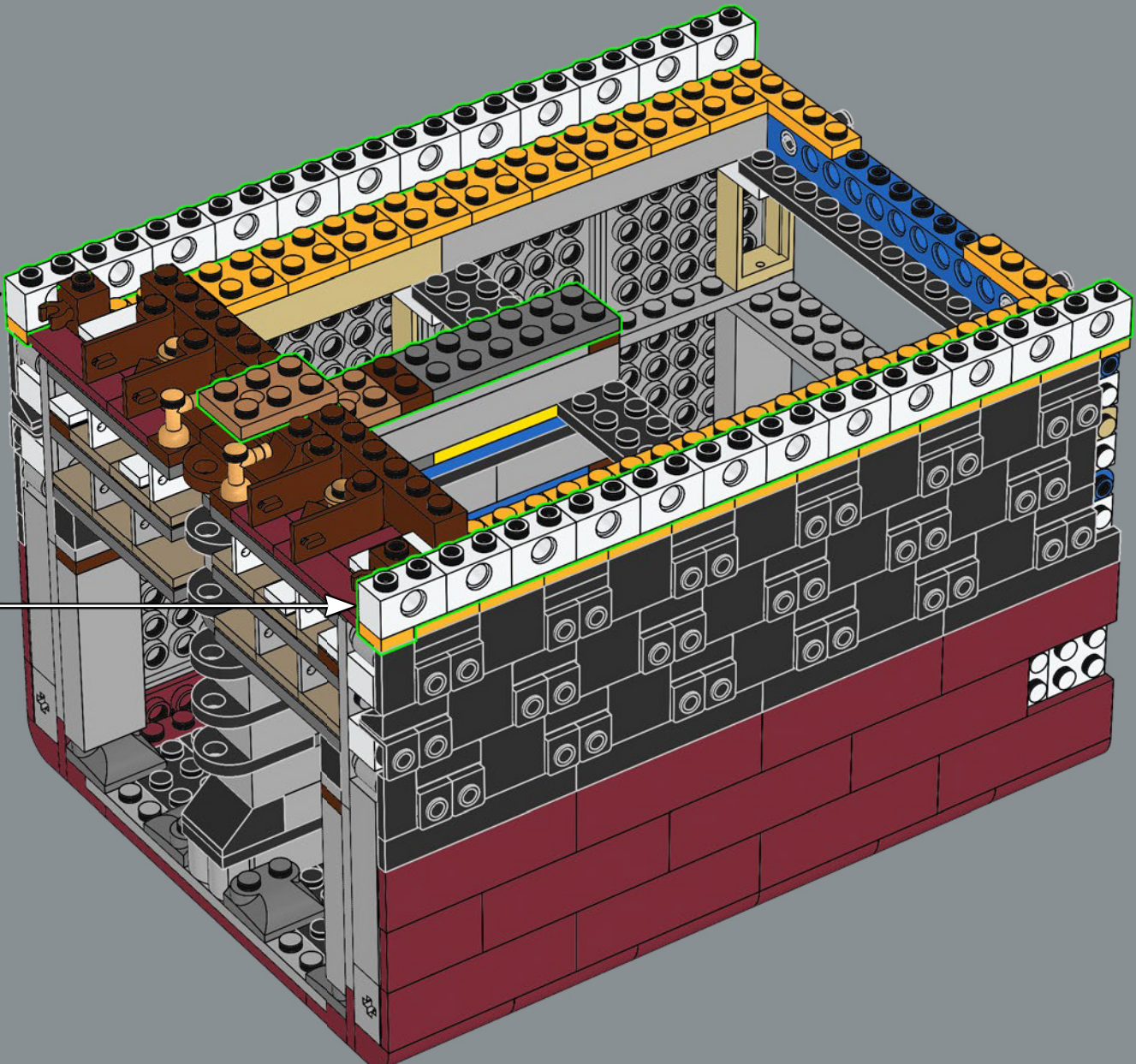
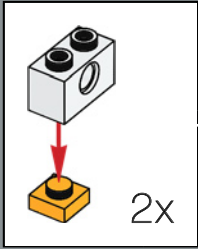

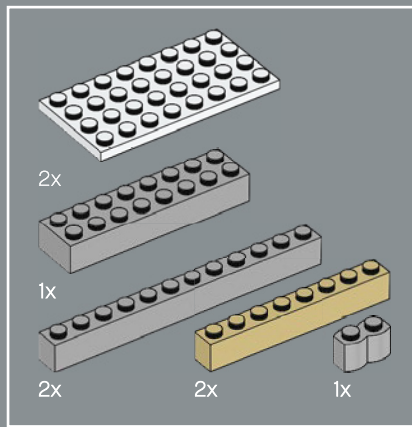

205

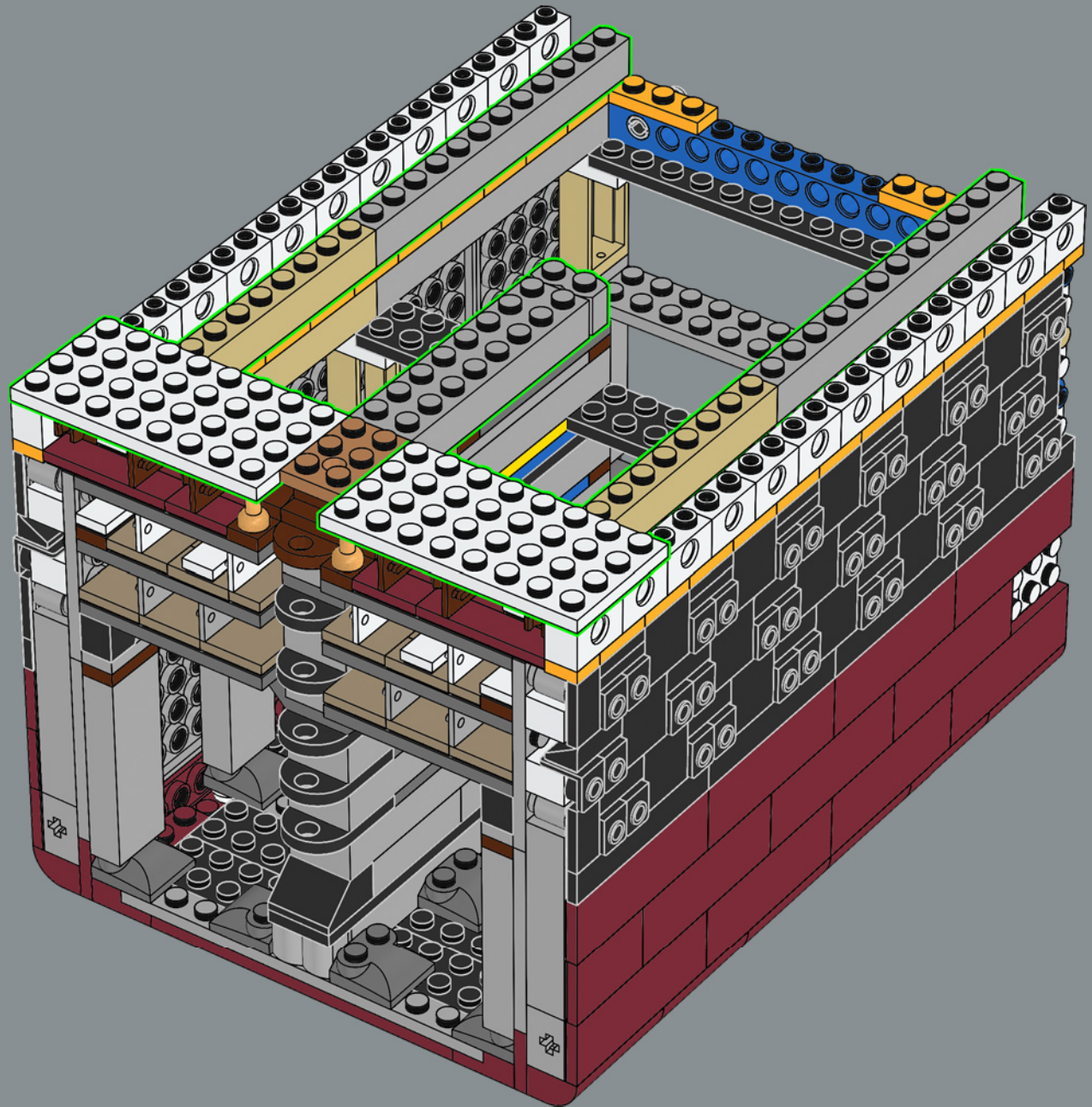

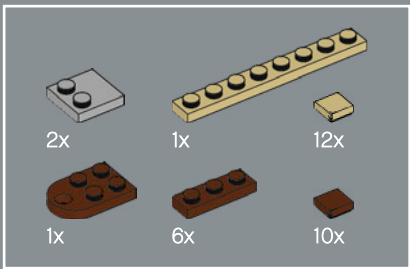

206

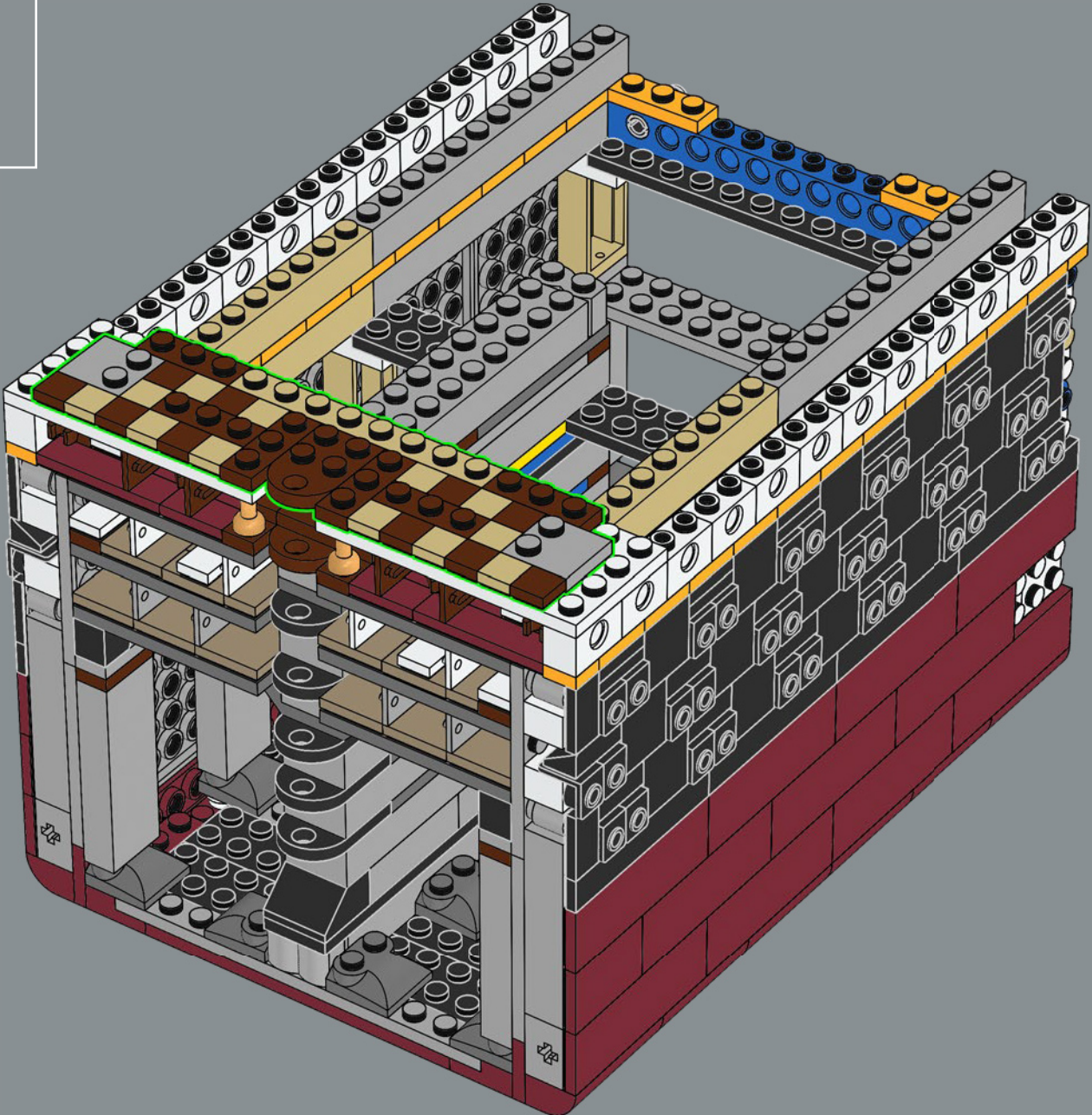

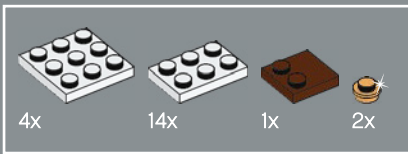

207

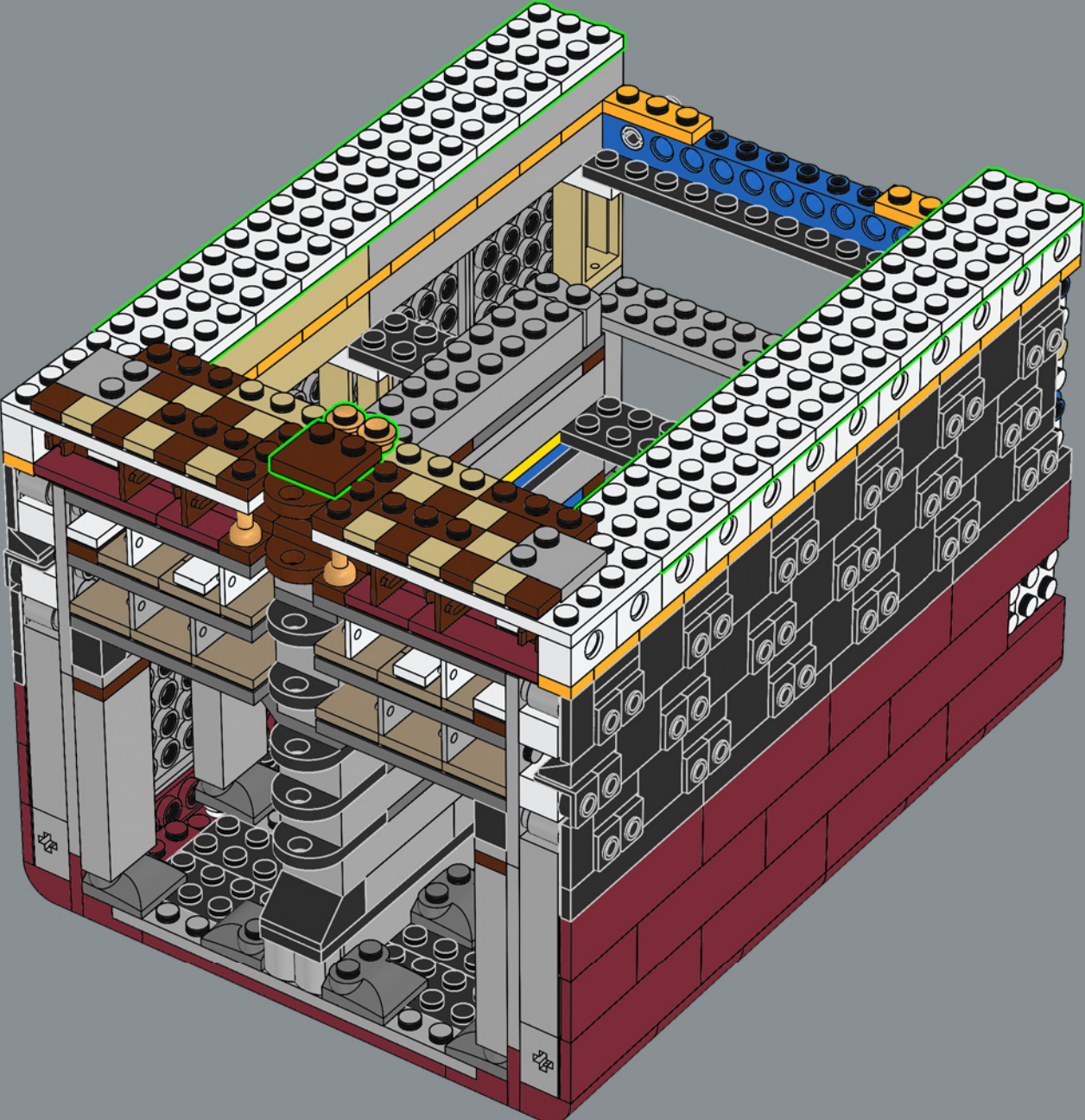

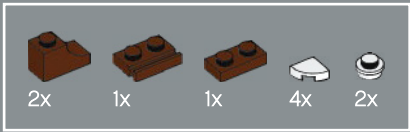

208

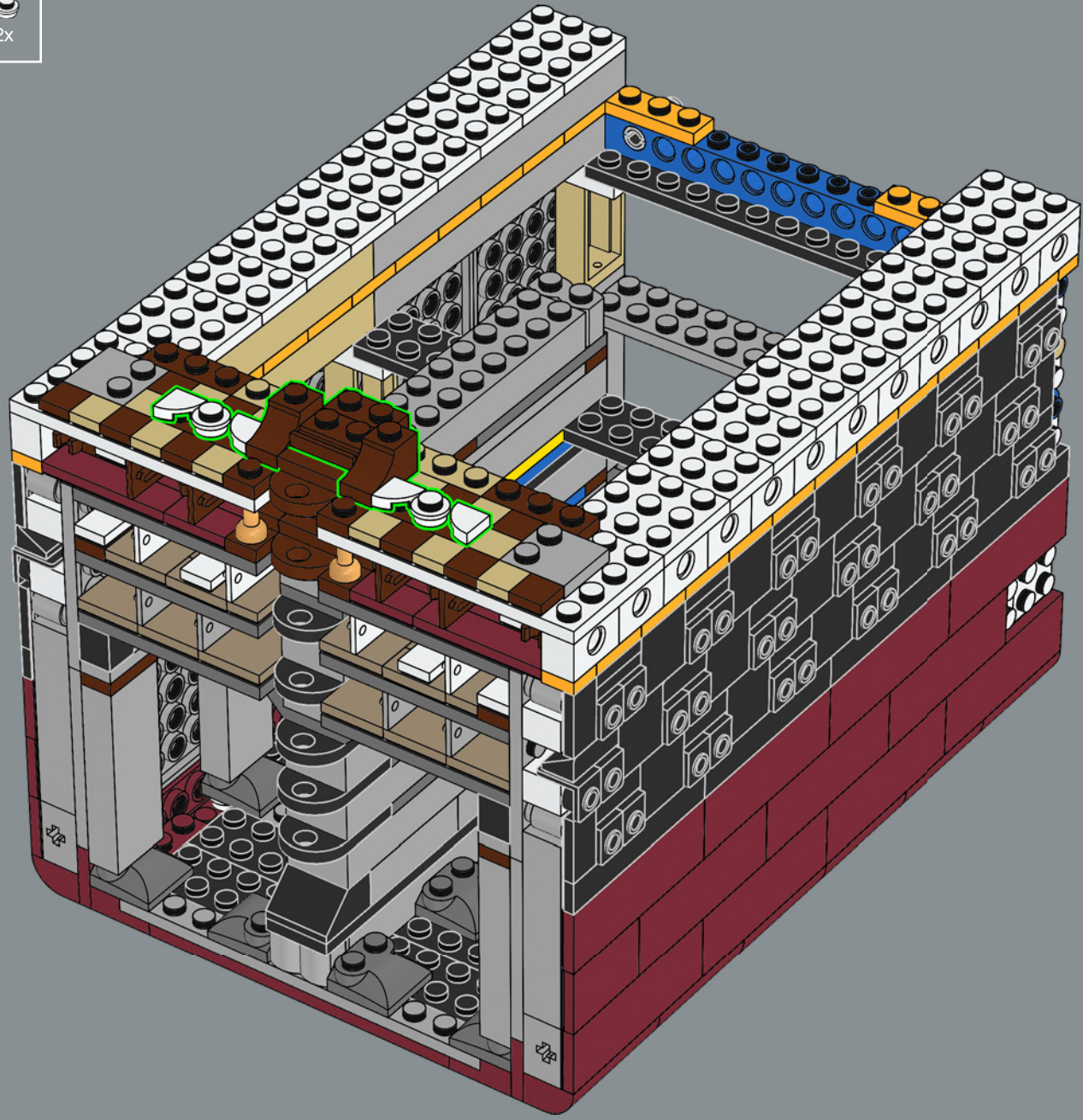

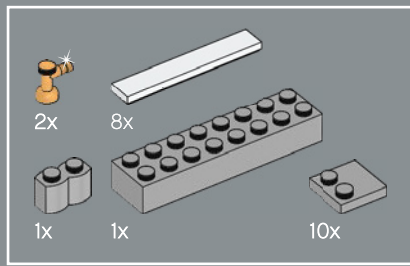

209

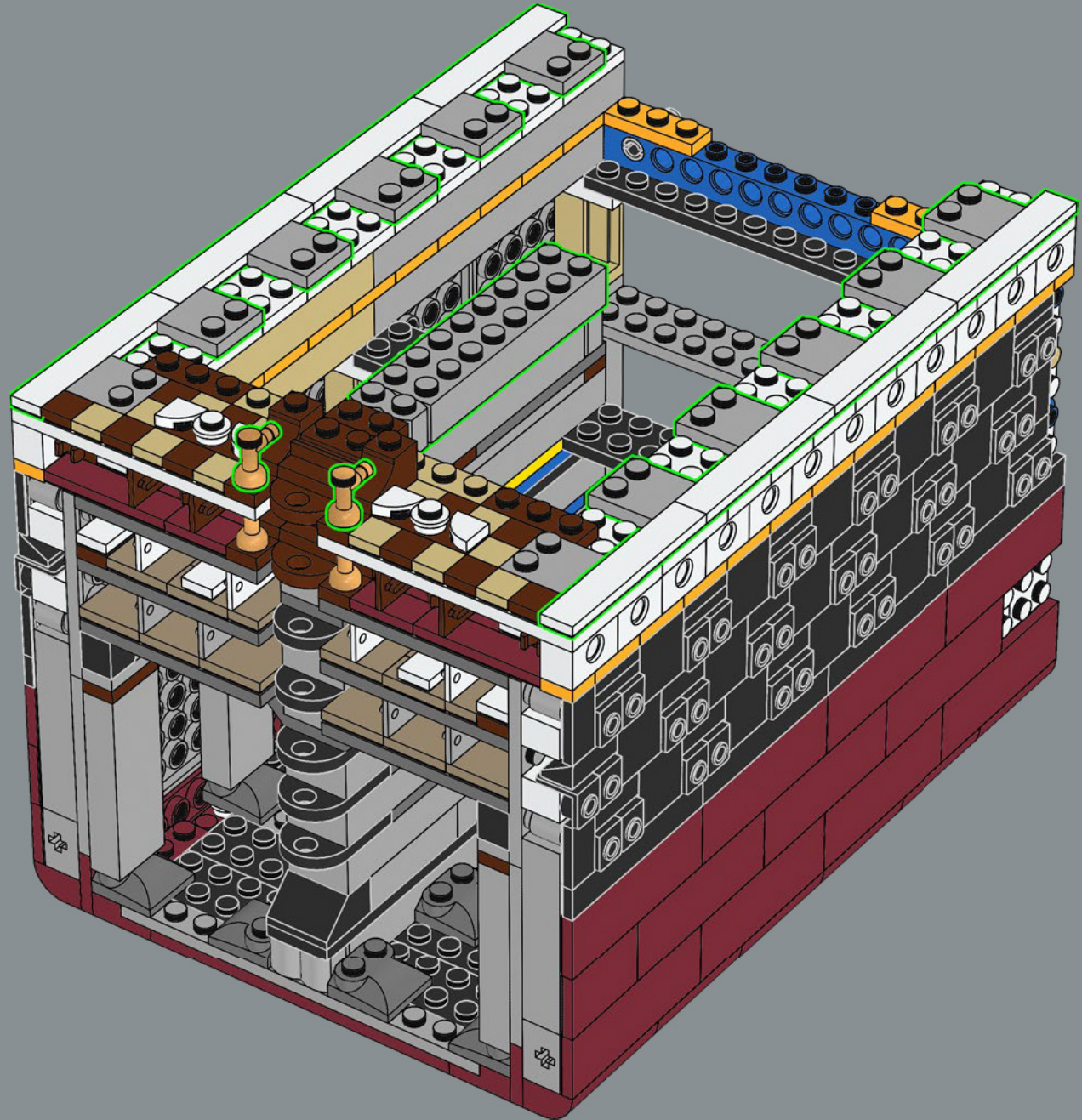

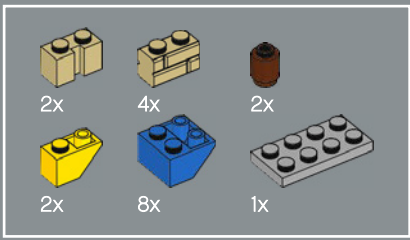

210

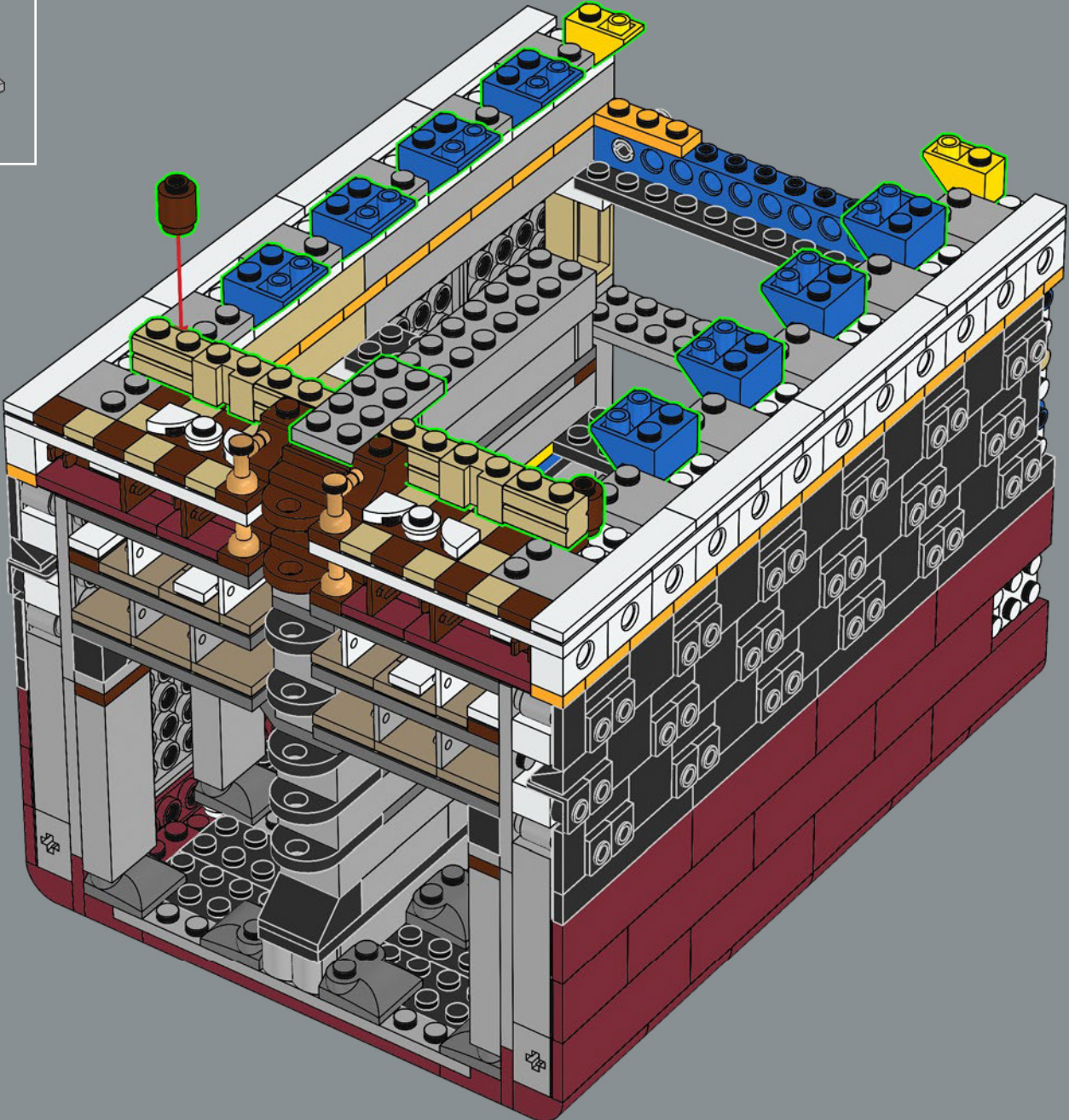

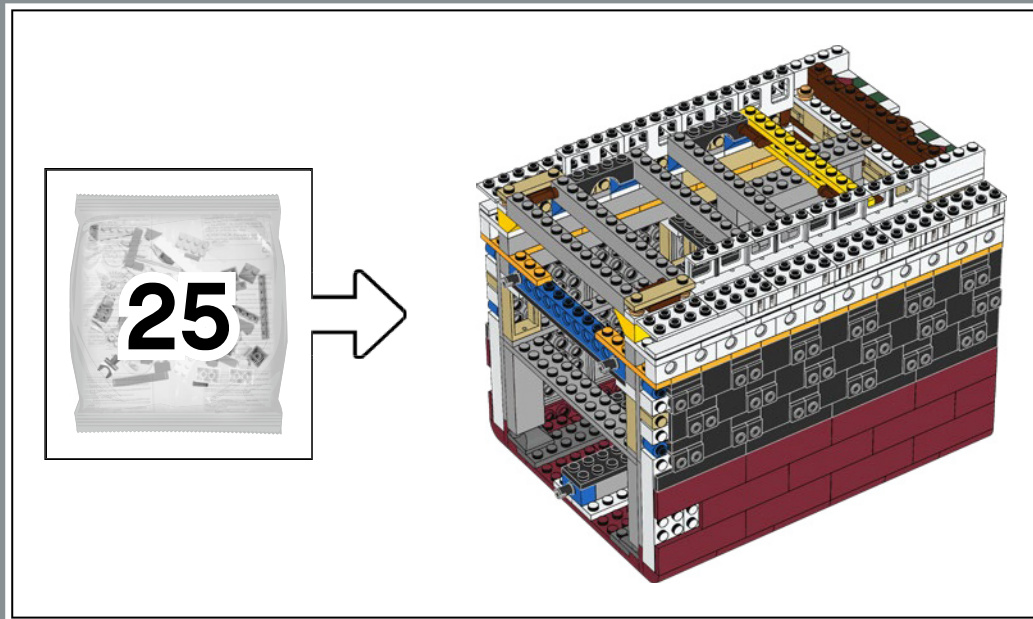



211

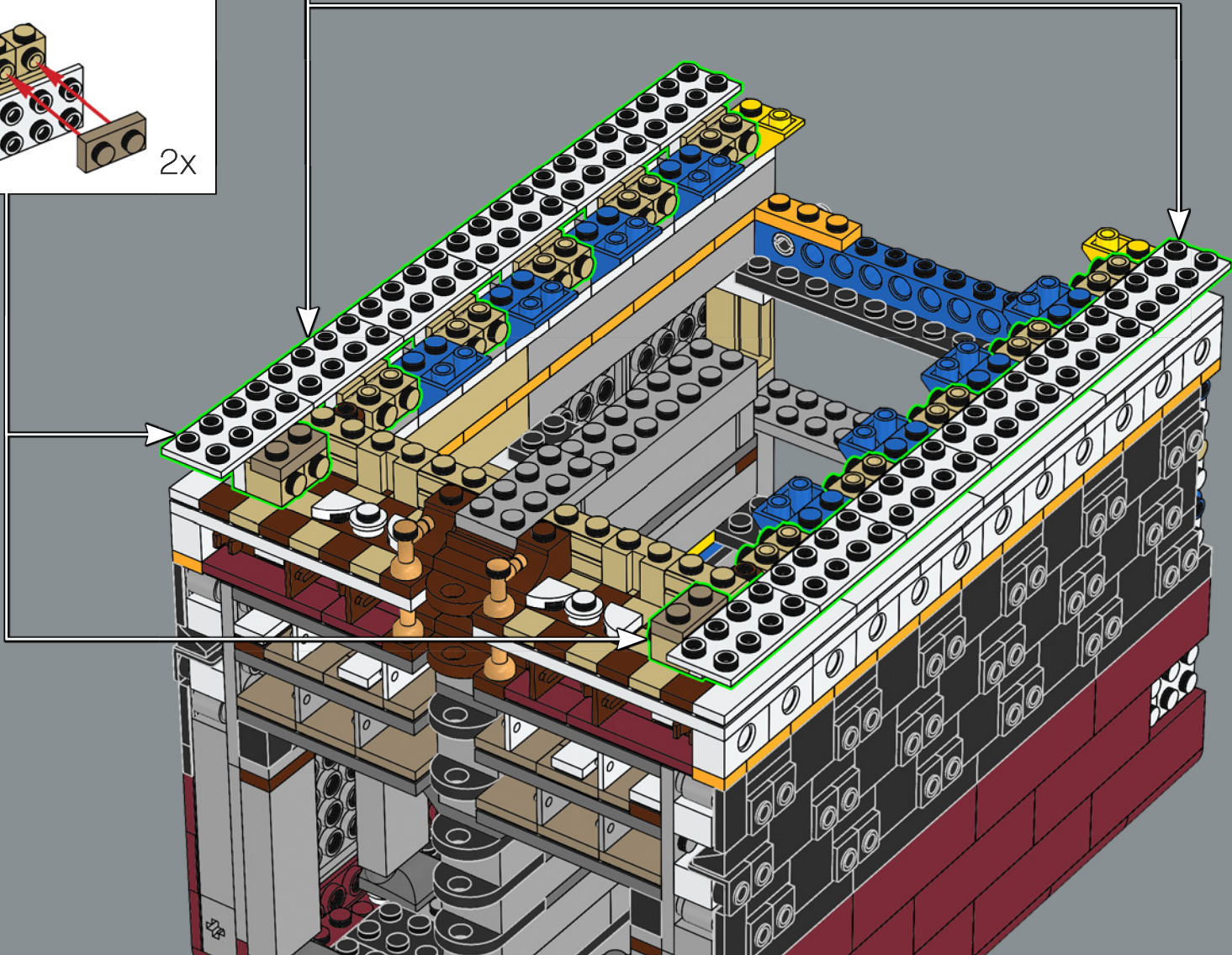
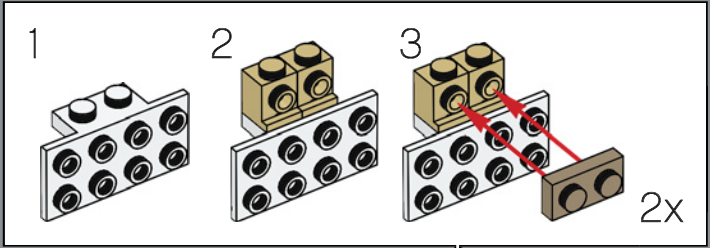
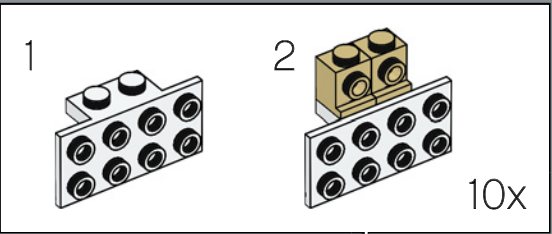

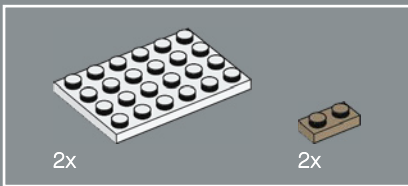

212

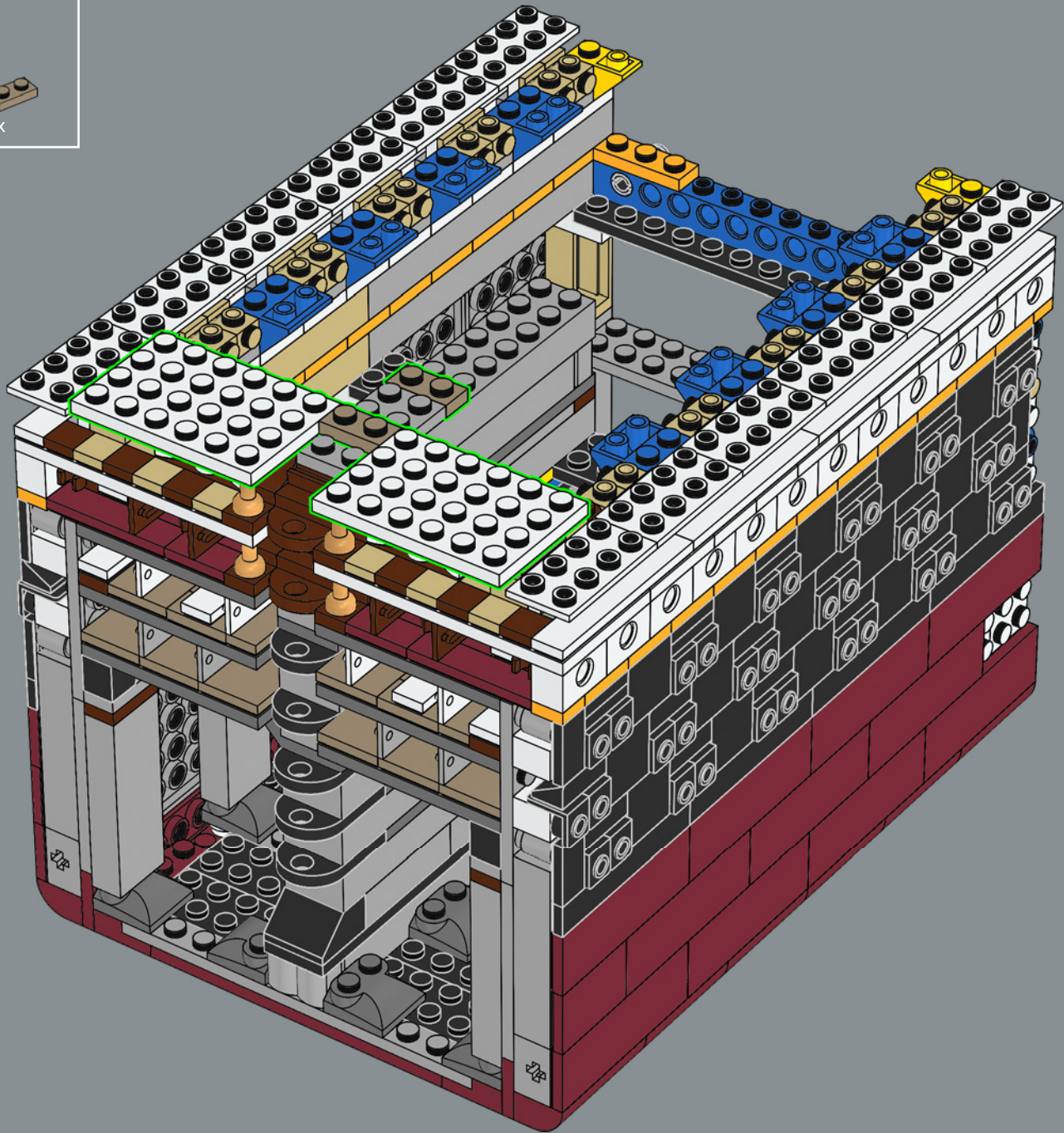

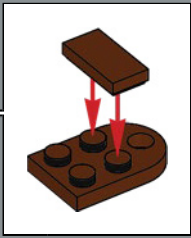
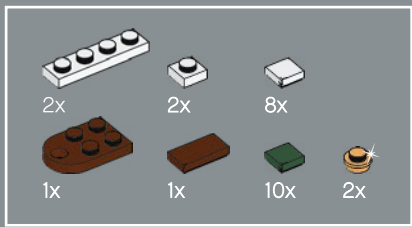

213

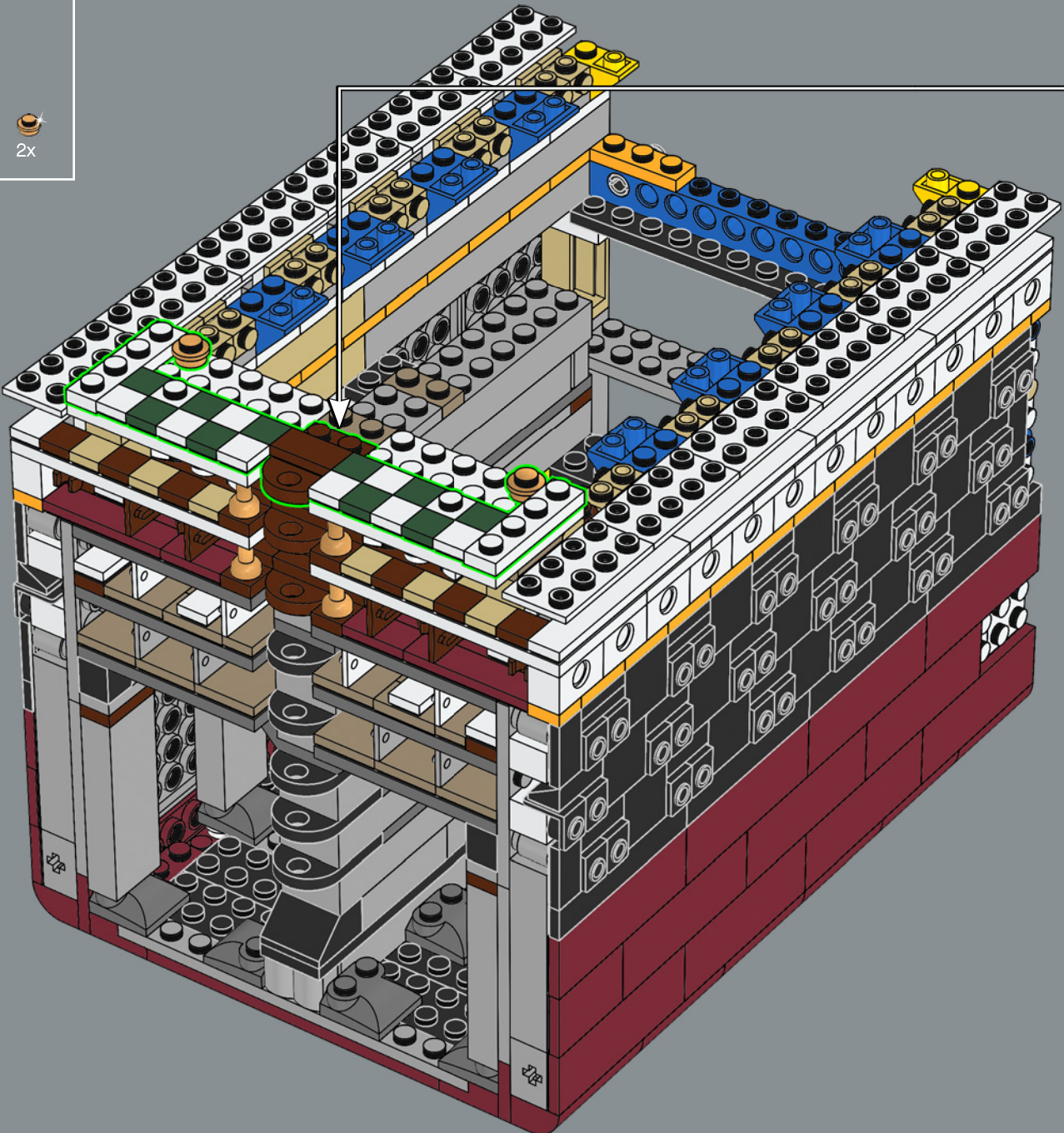

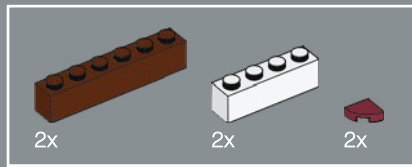

214

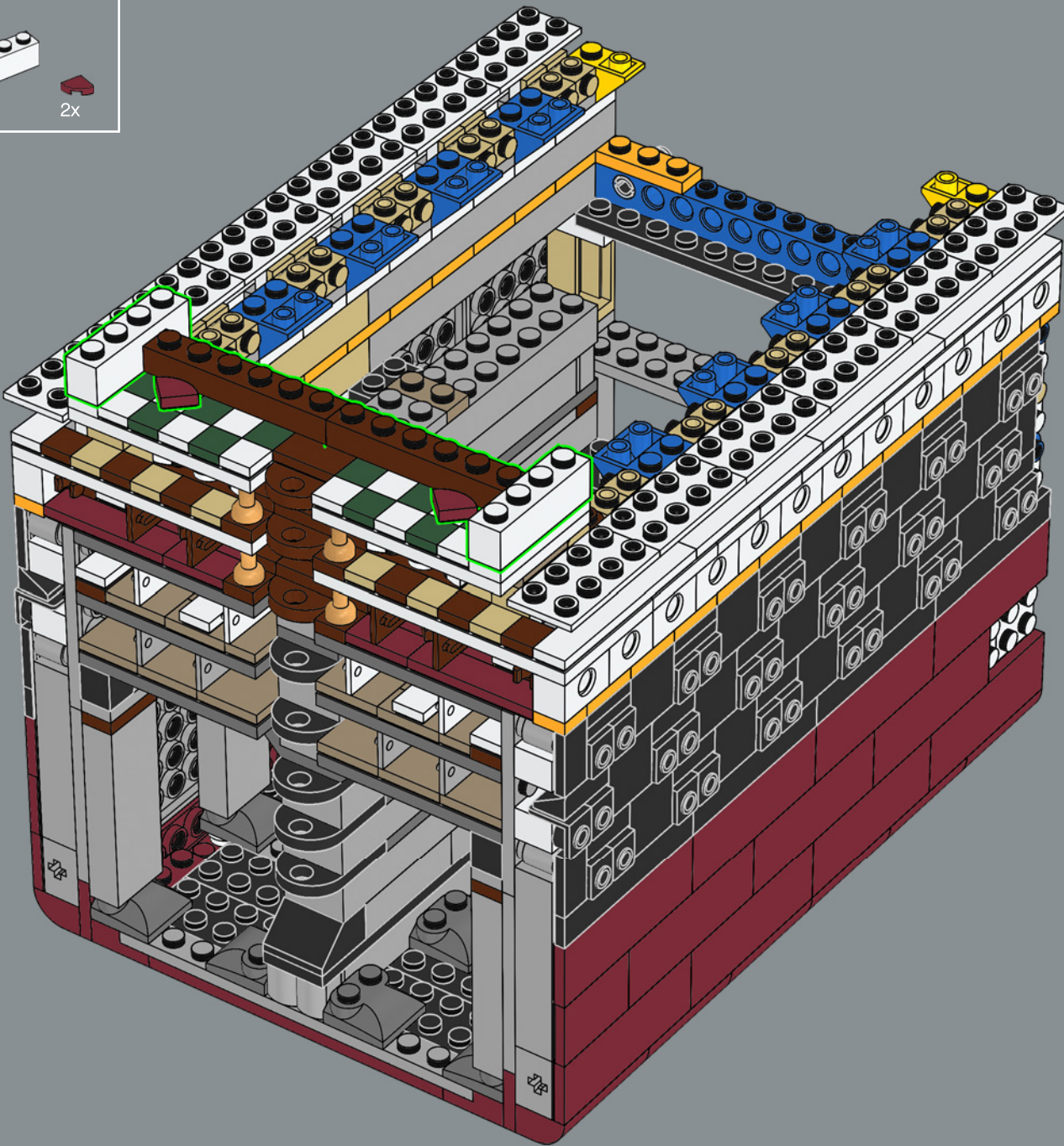

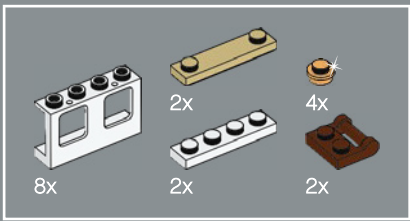

215

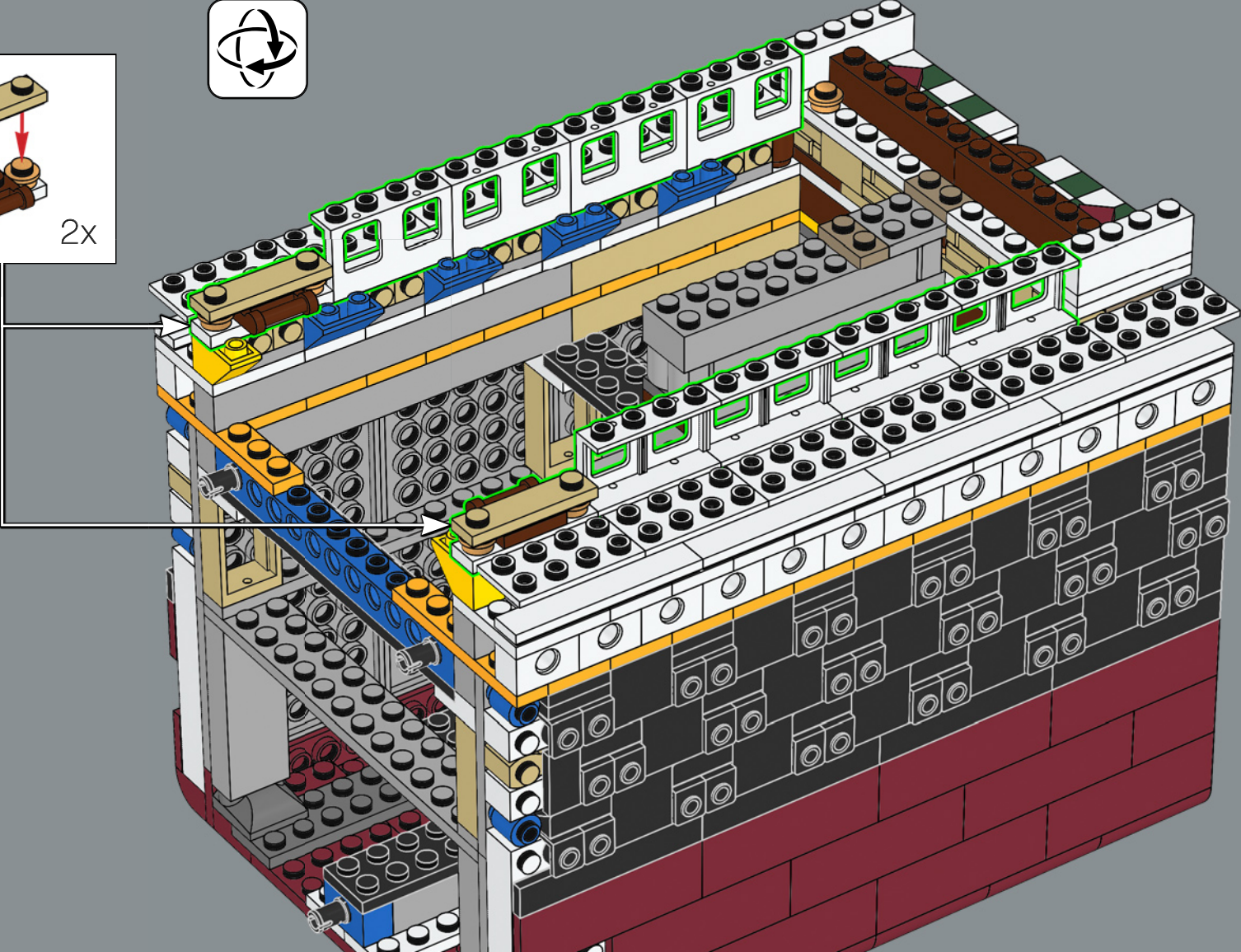
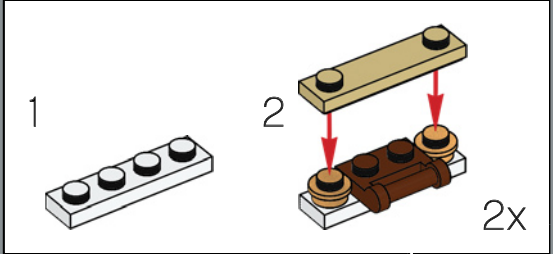

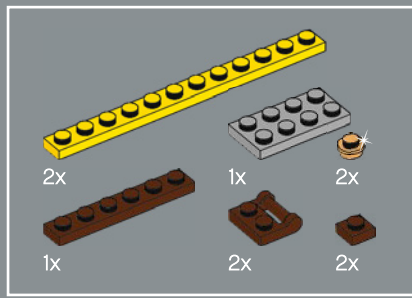

216

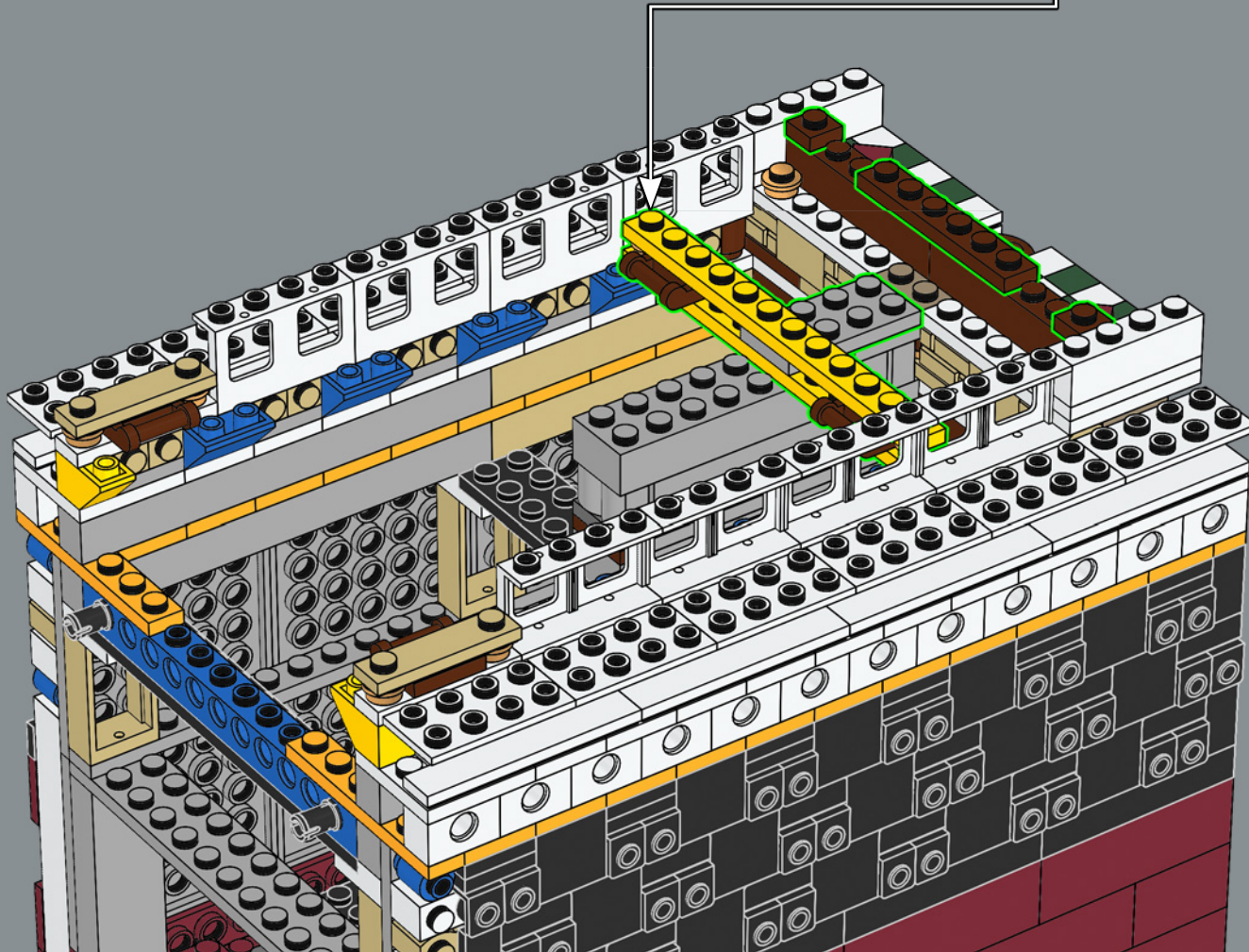
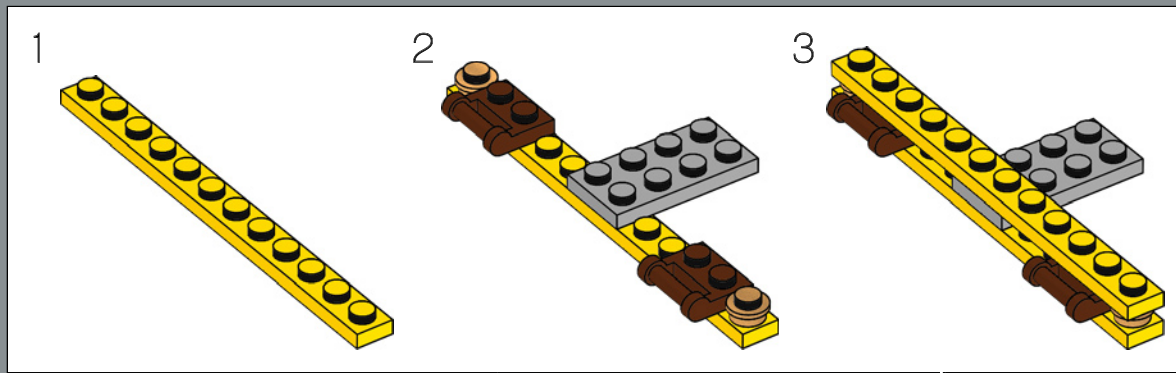

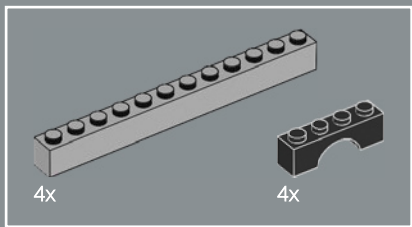

217

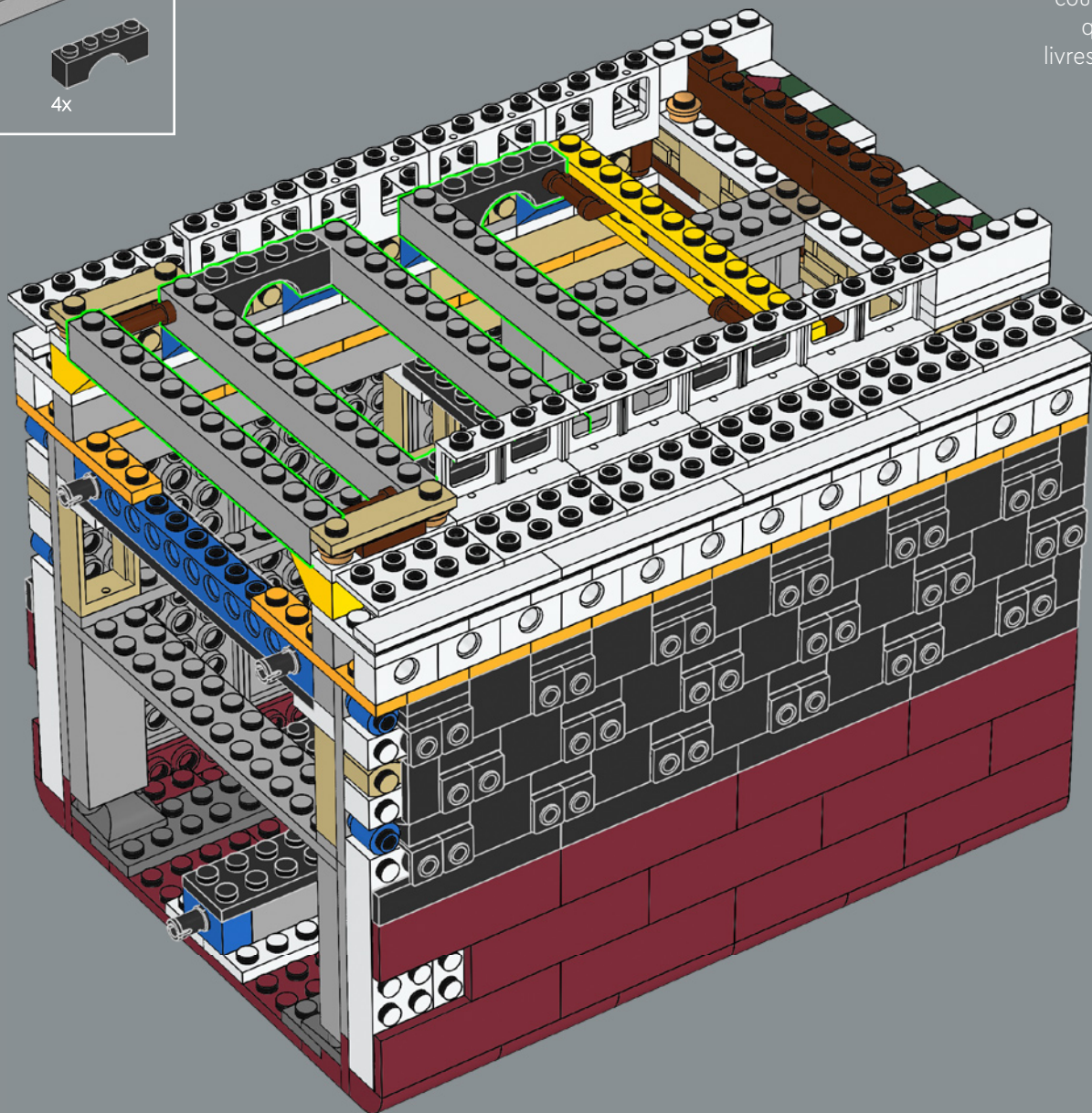

La construction du Titanic et de l'Olympic a coûté environ 3 millions de livres sterling, ce qui équivaut aujourd'hui à 300 millions de livres sterling (environ 350,3 millions d'euros).

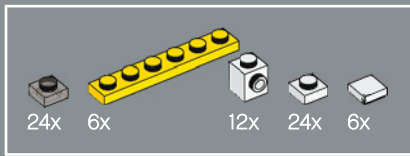

218

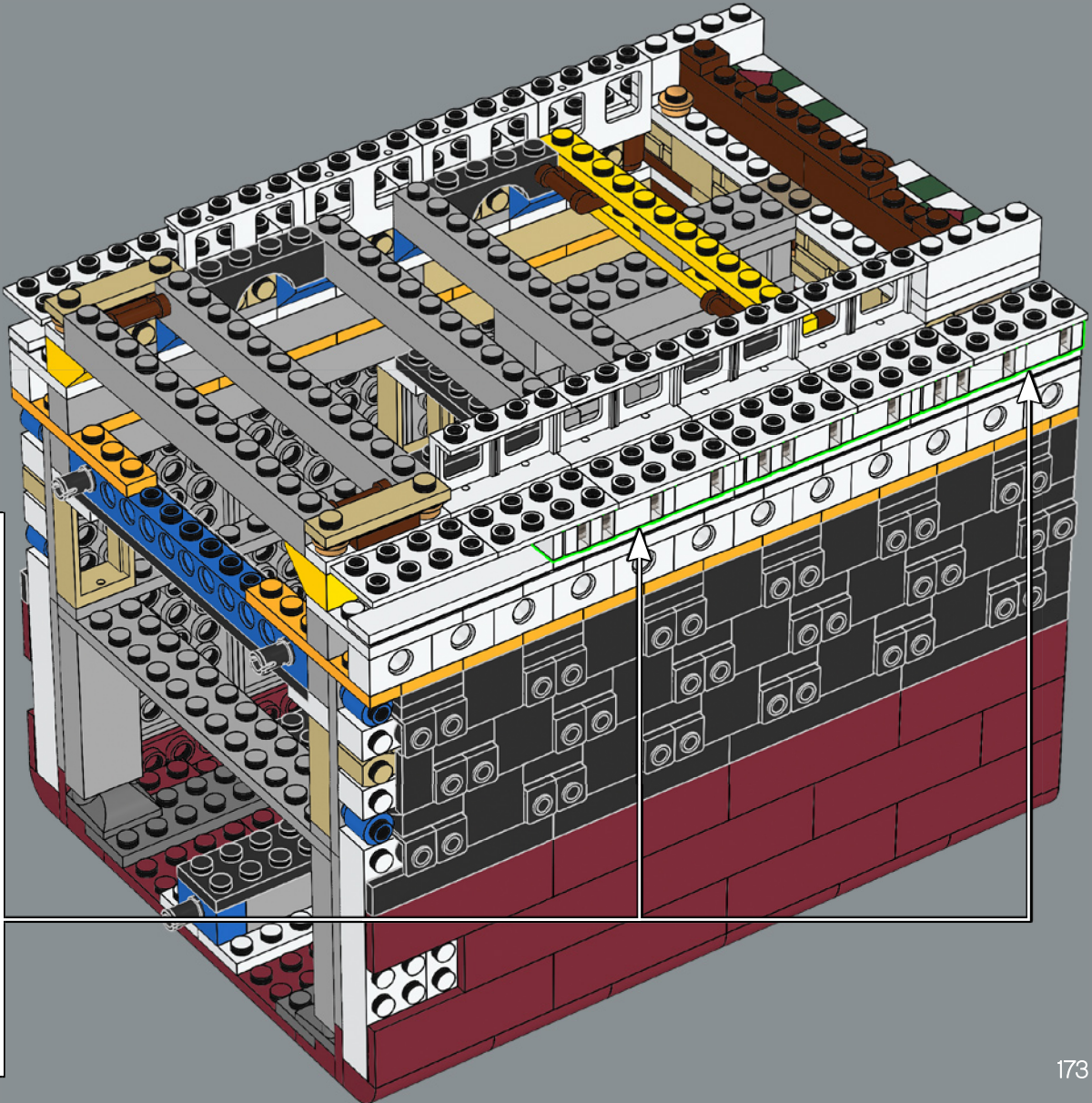
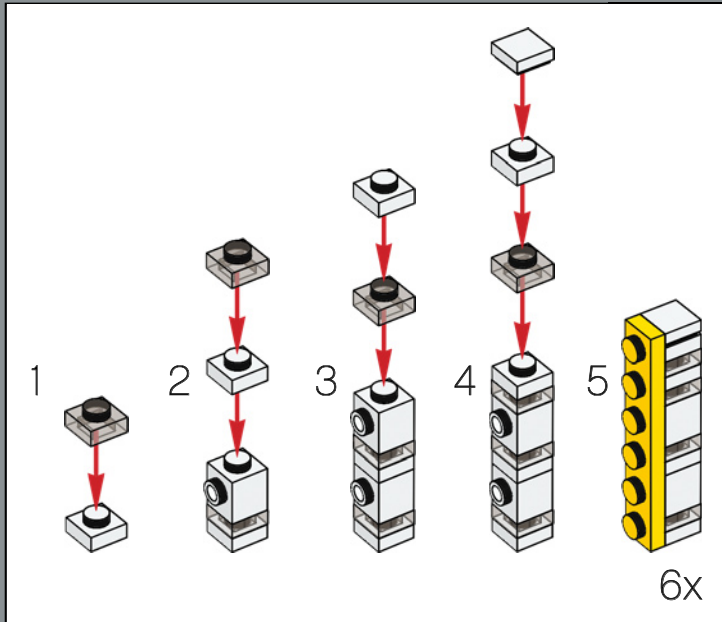

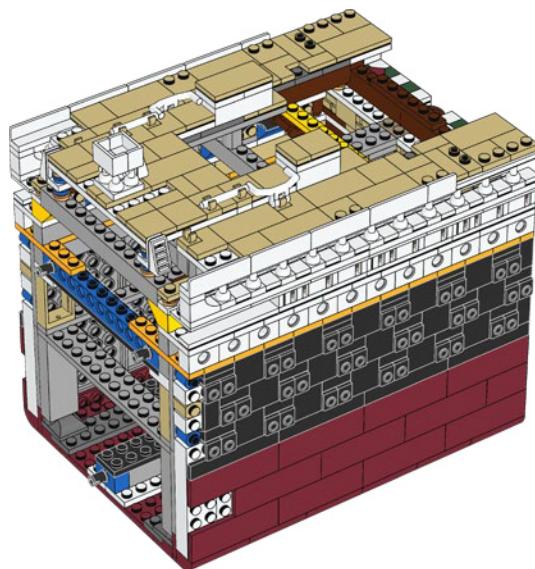
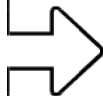

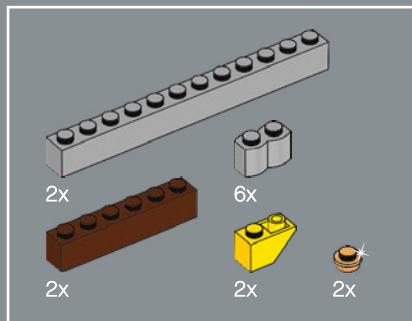

219

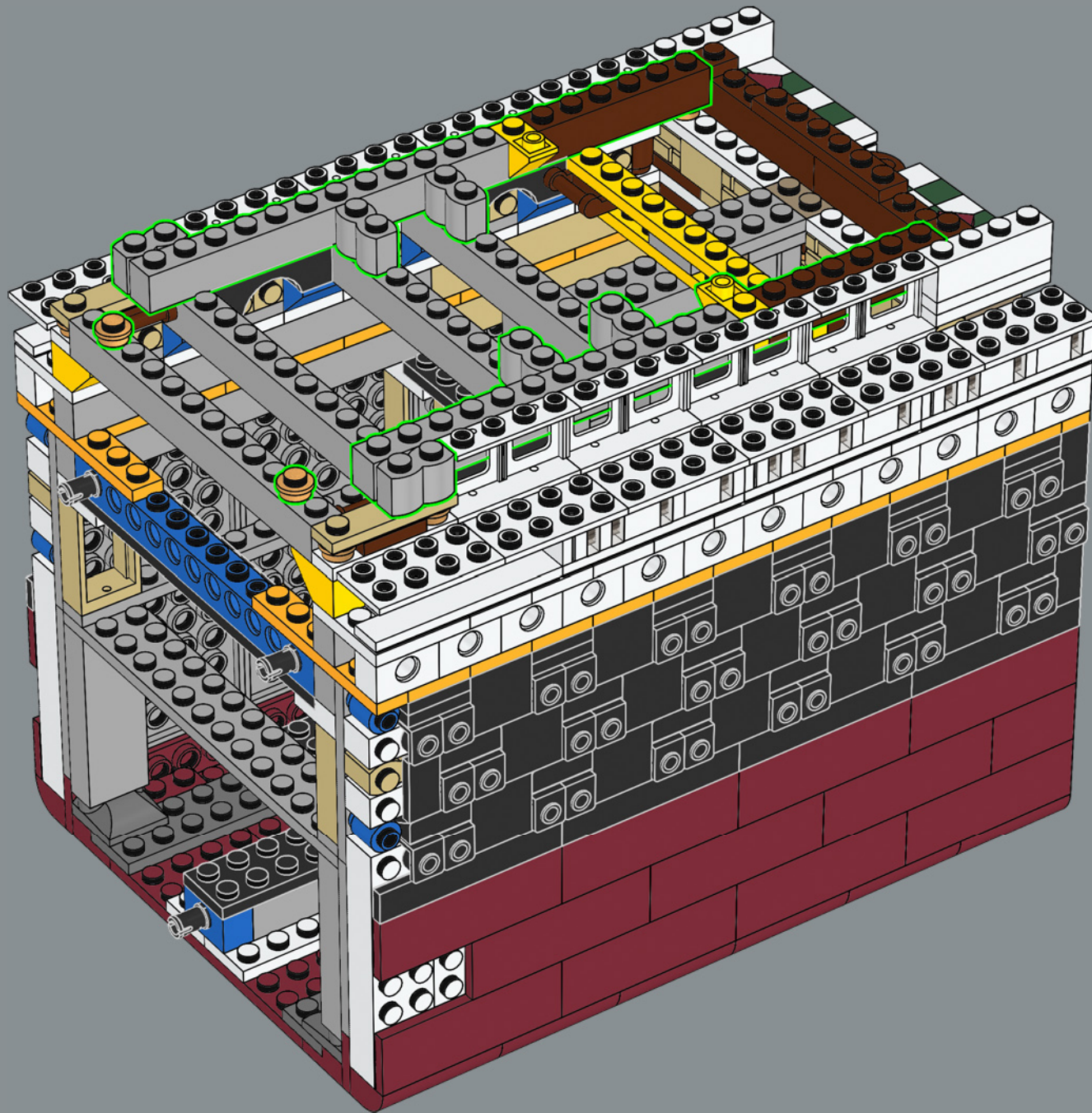

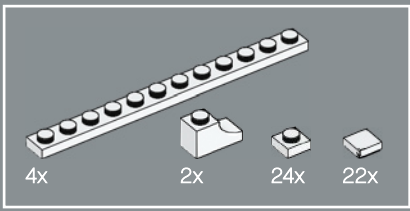

220

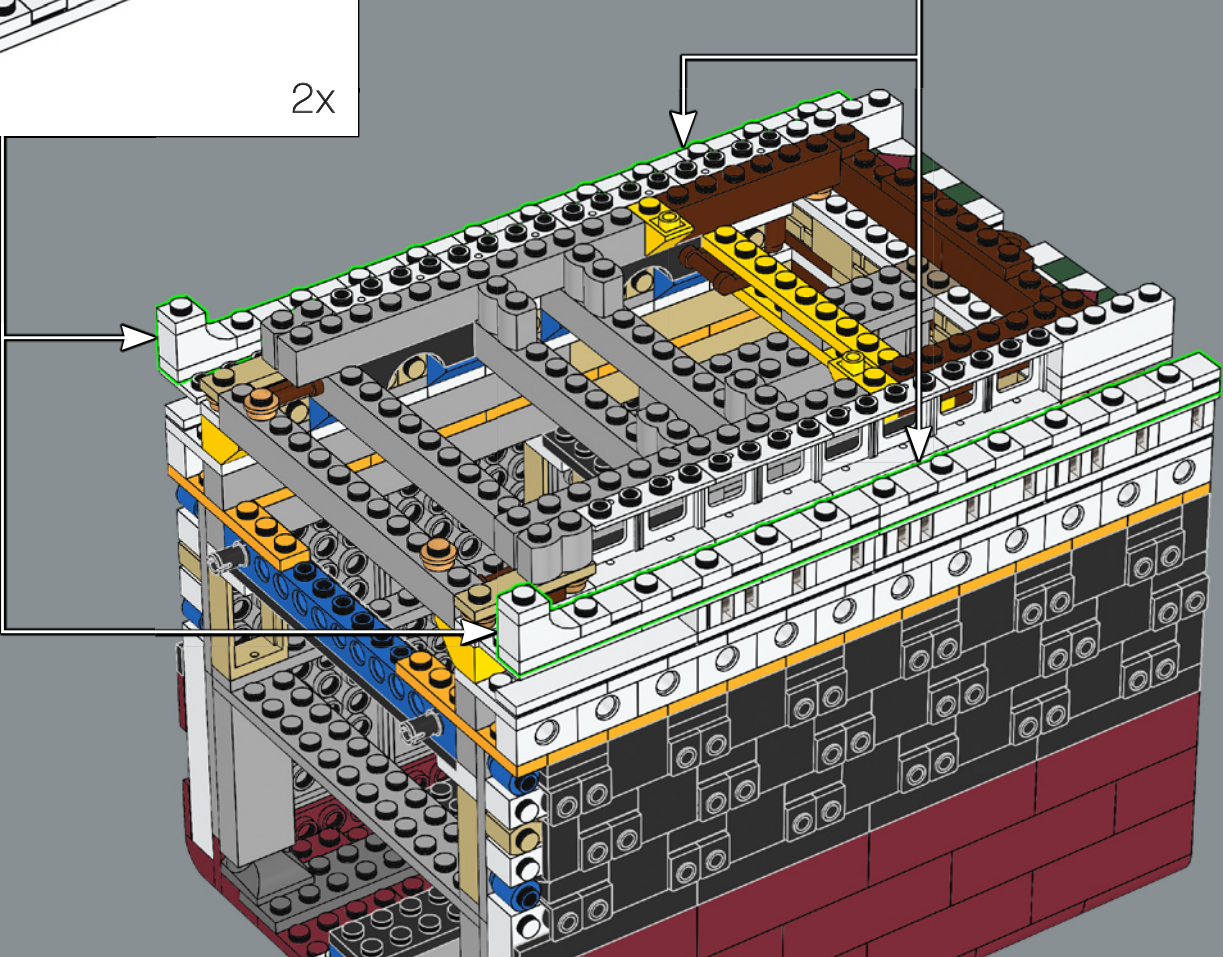
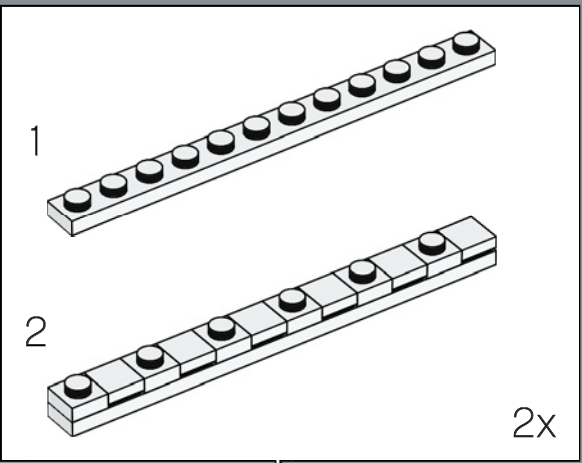
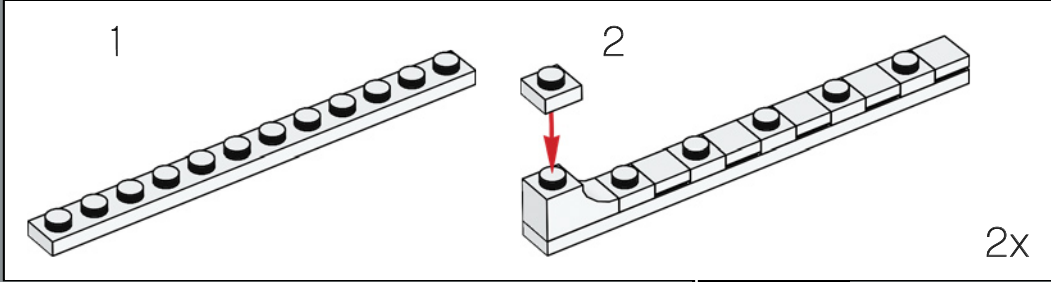

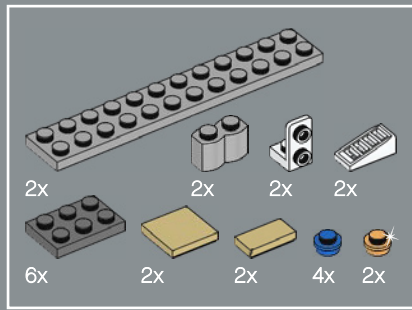

221

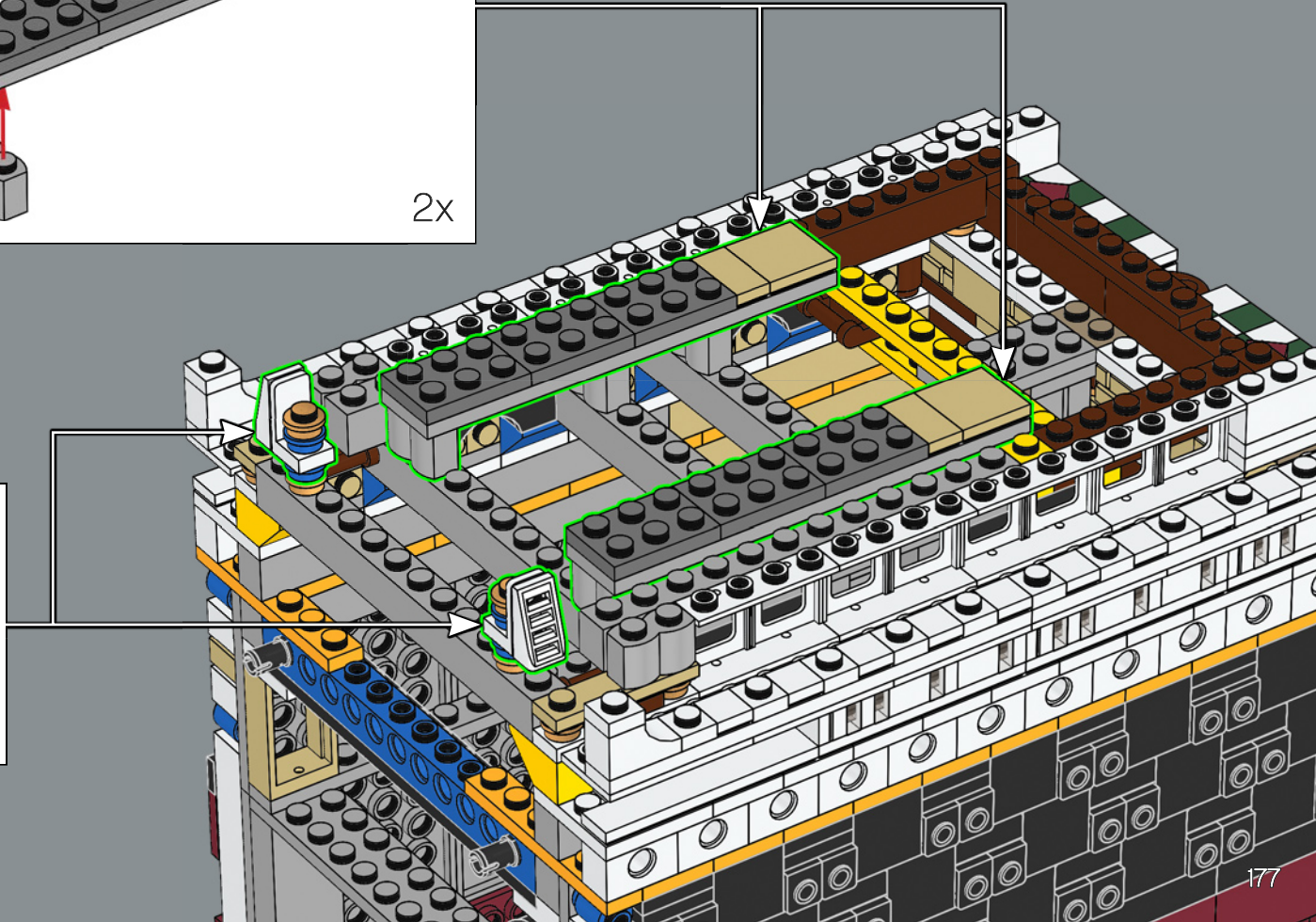
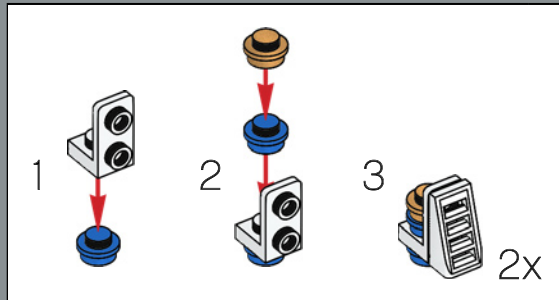
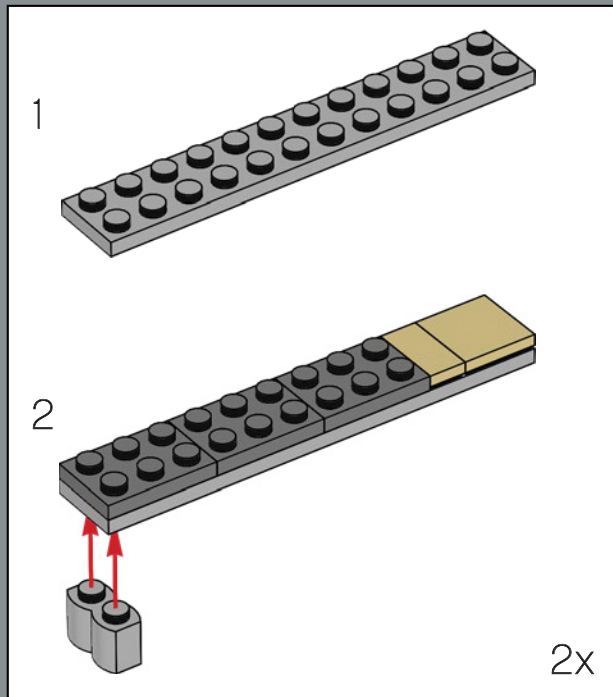

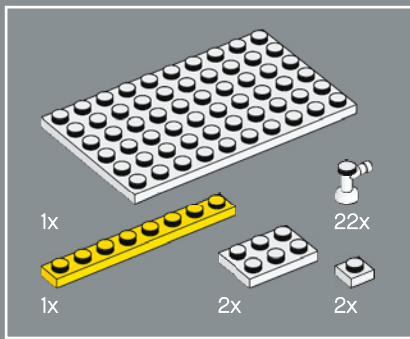

222

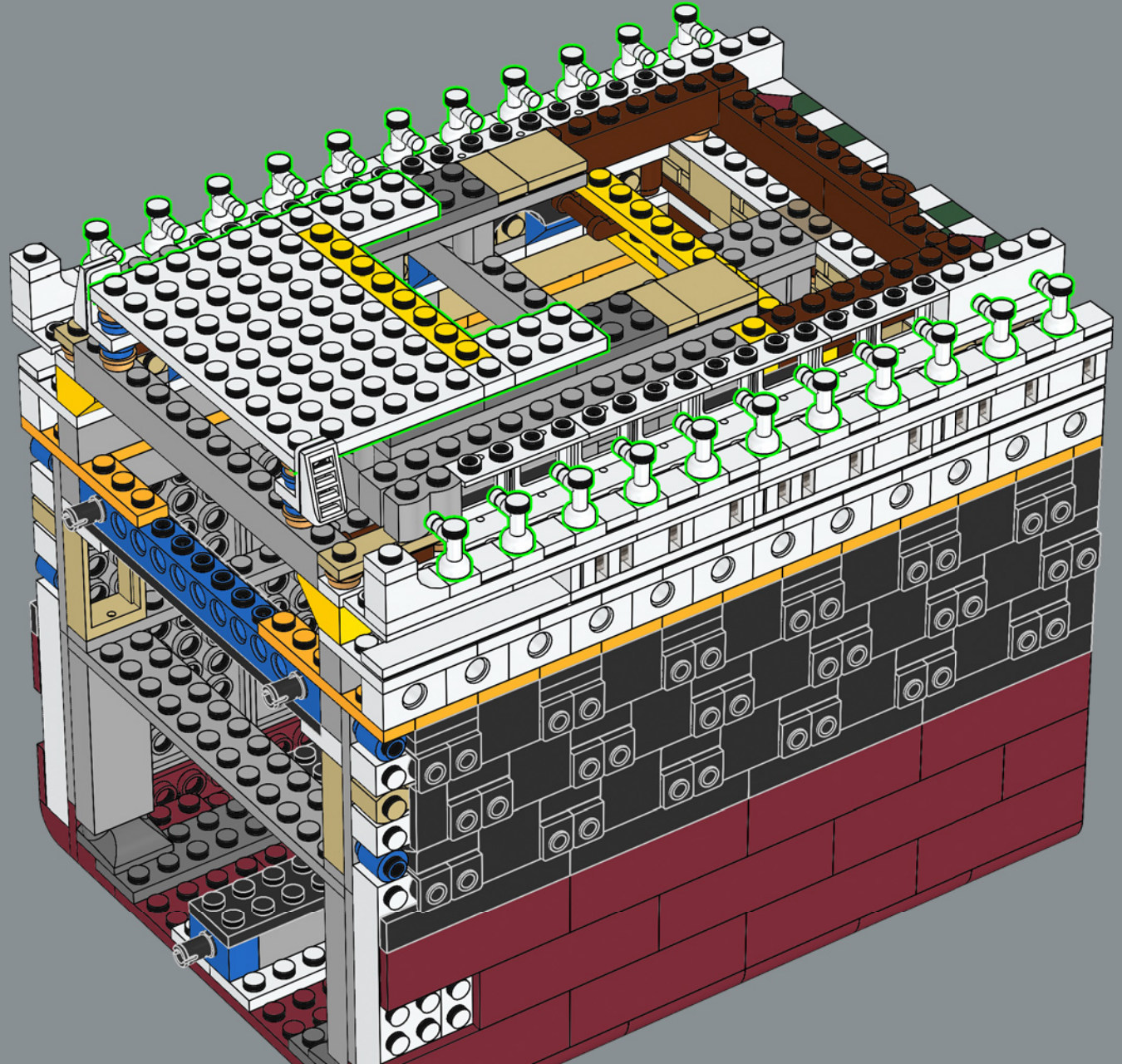

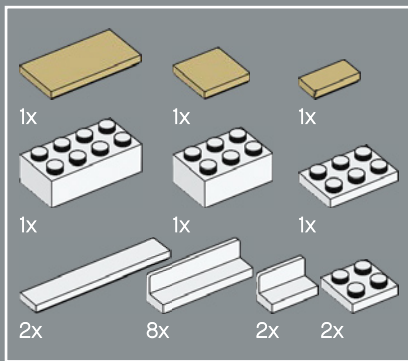

223

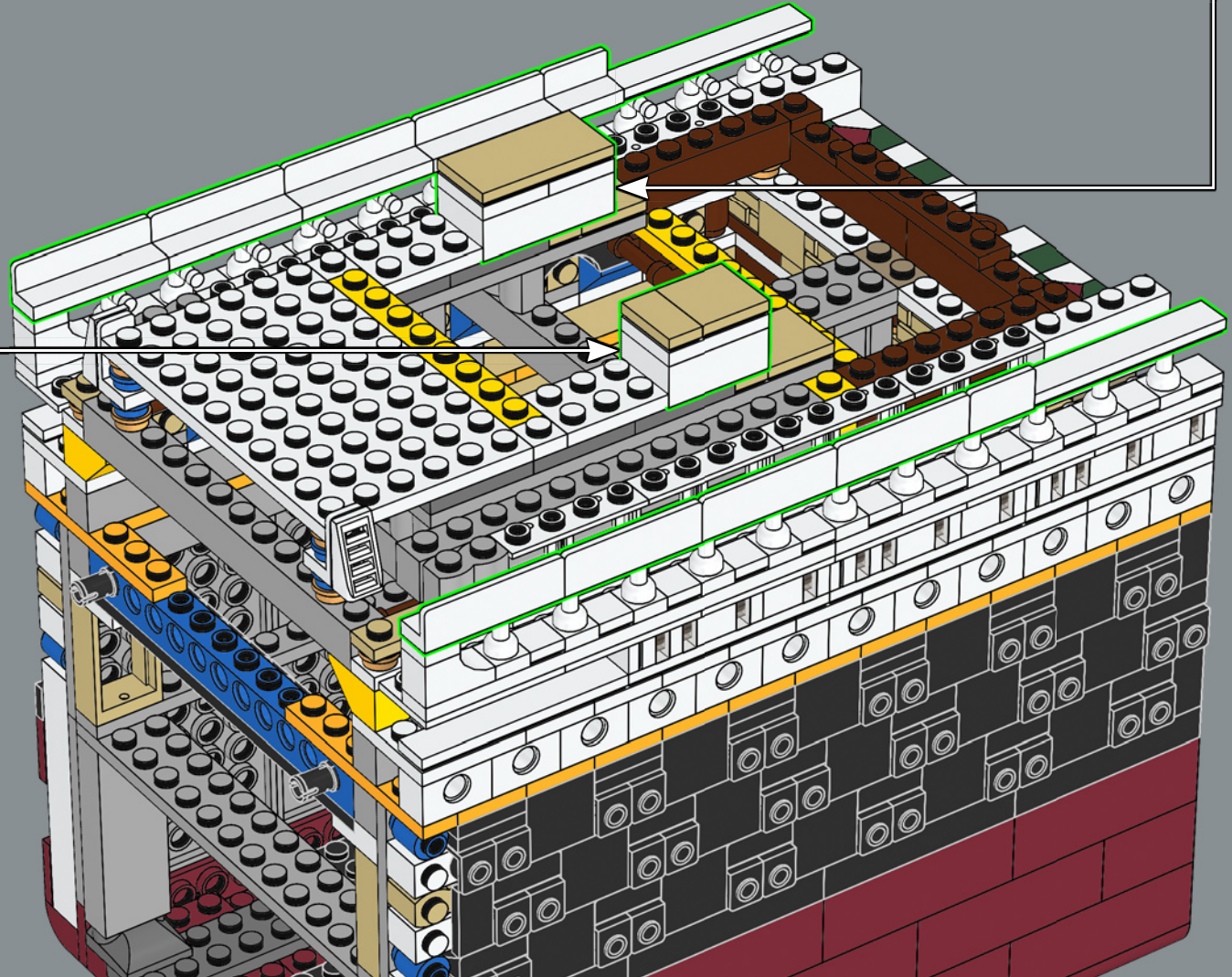
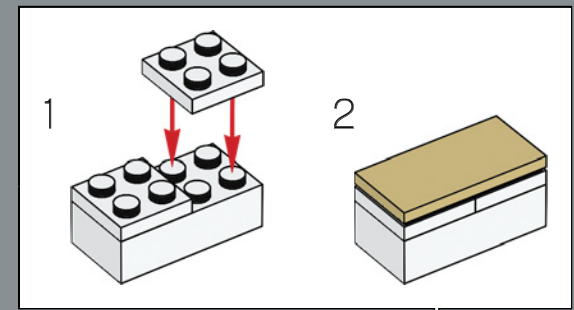
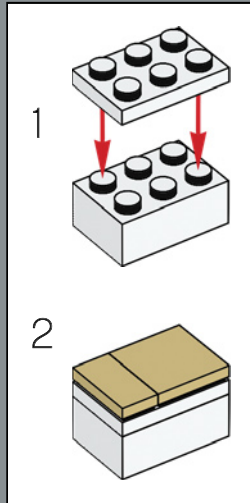

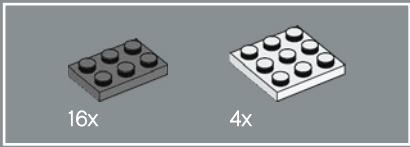

224

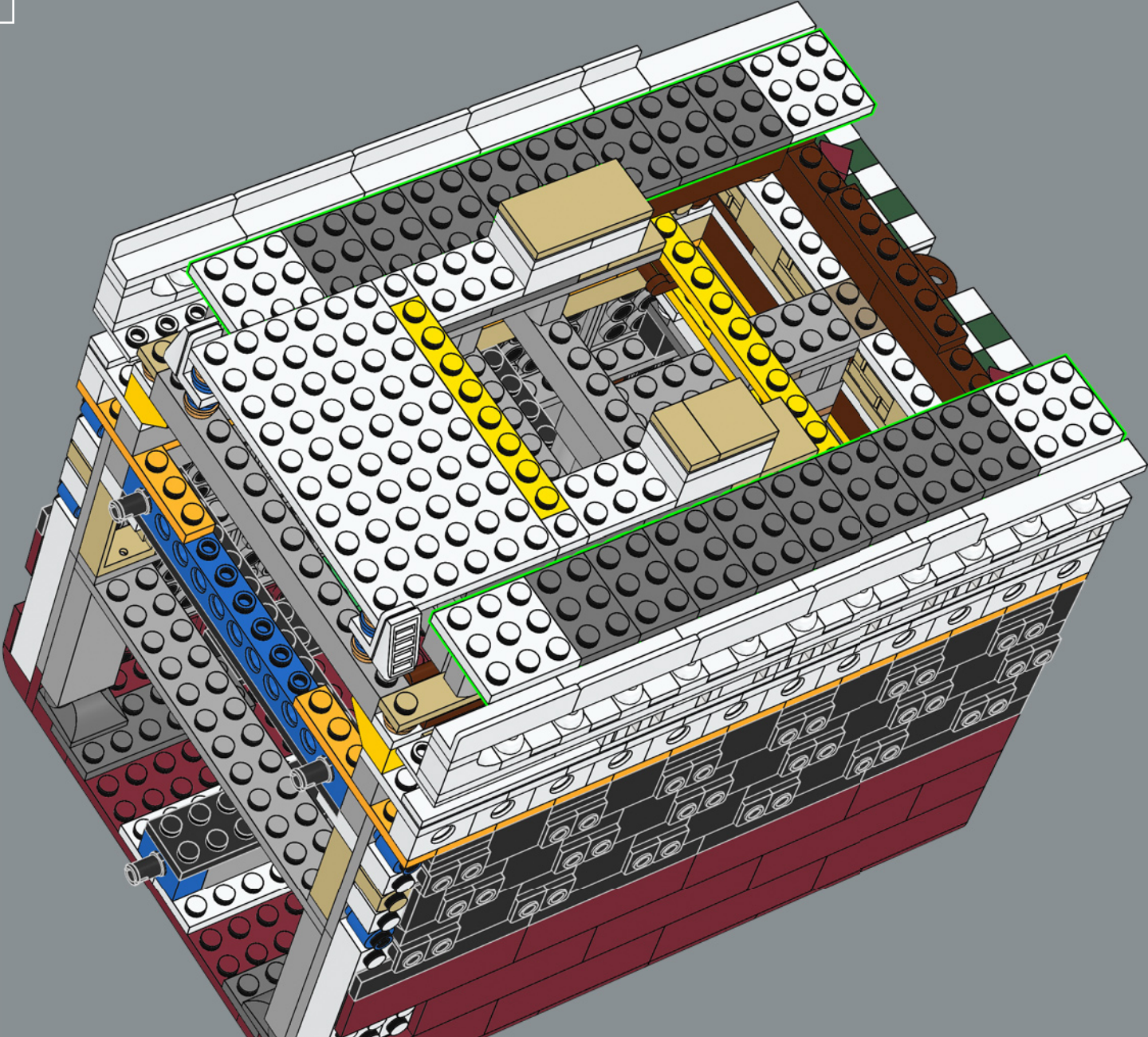

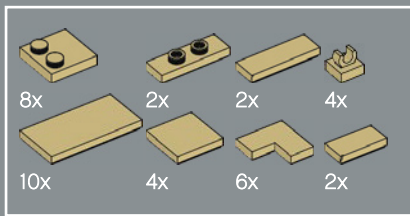

225

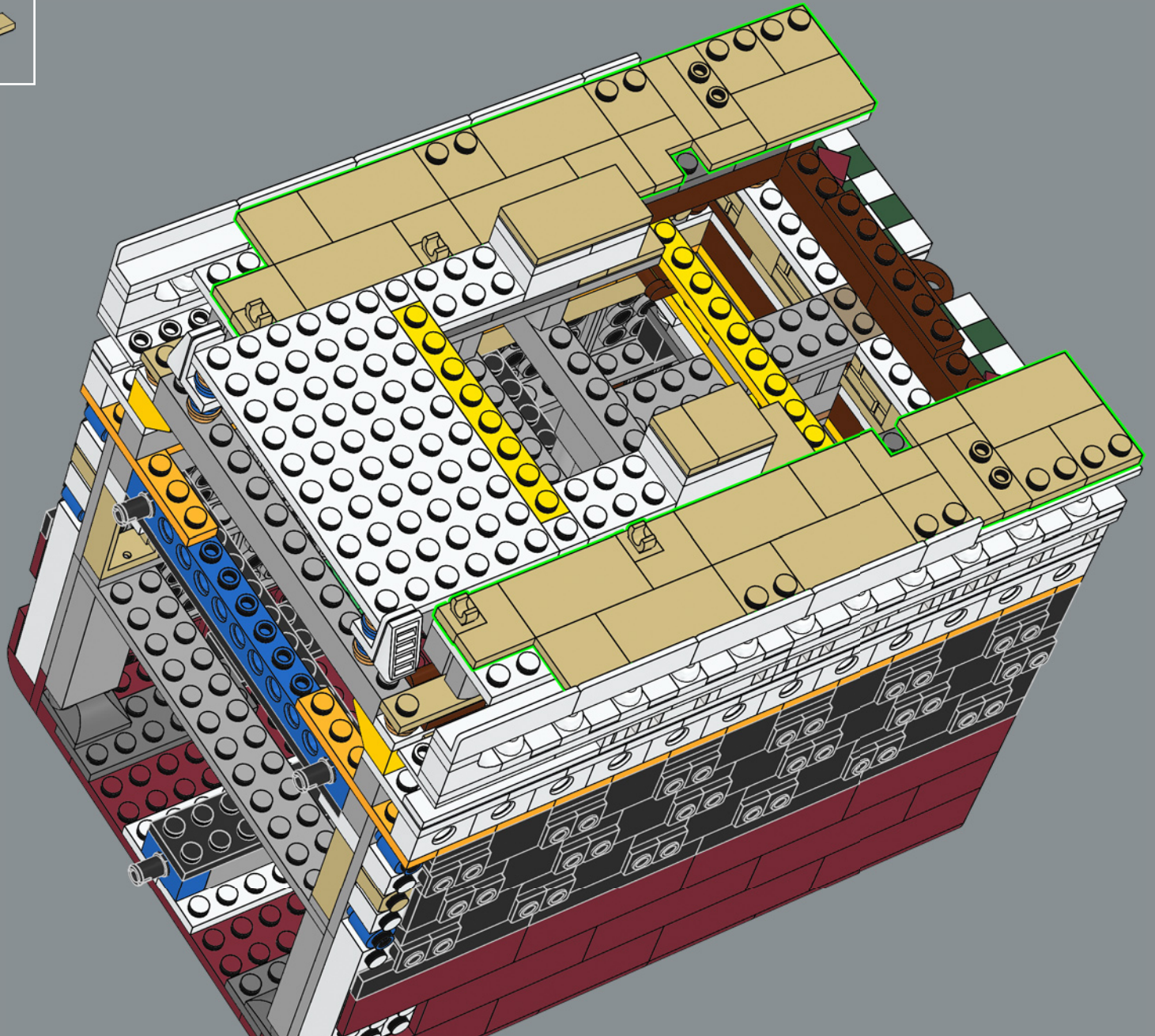

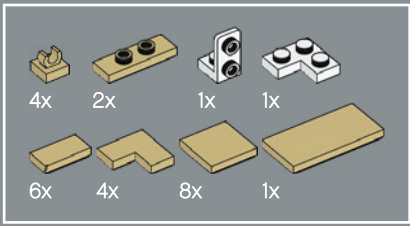

226

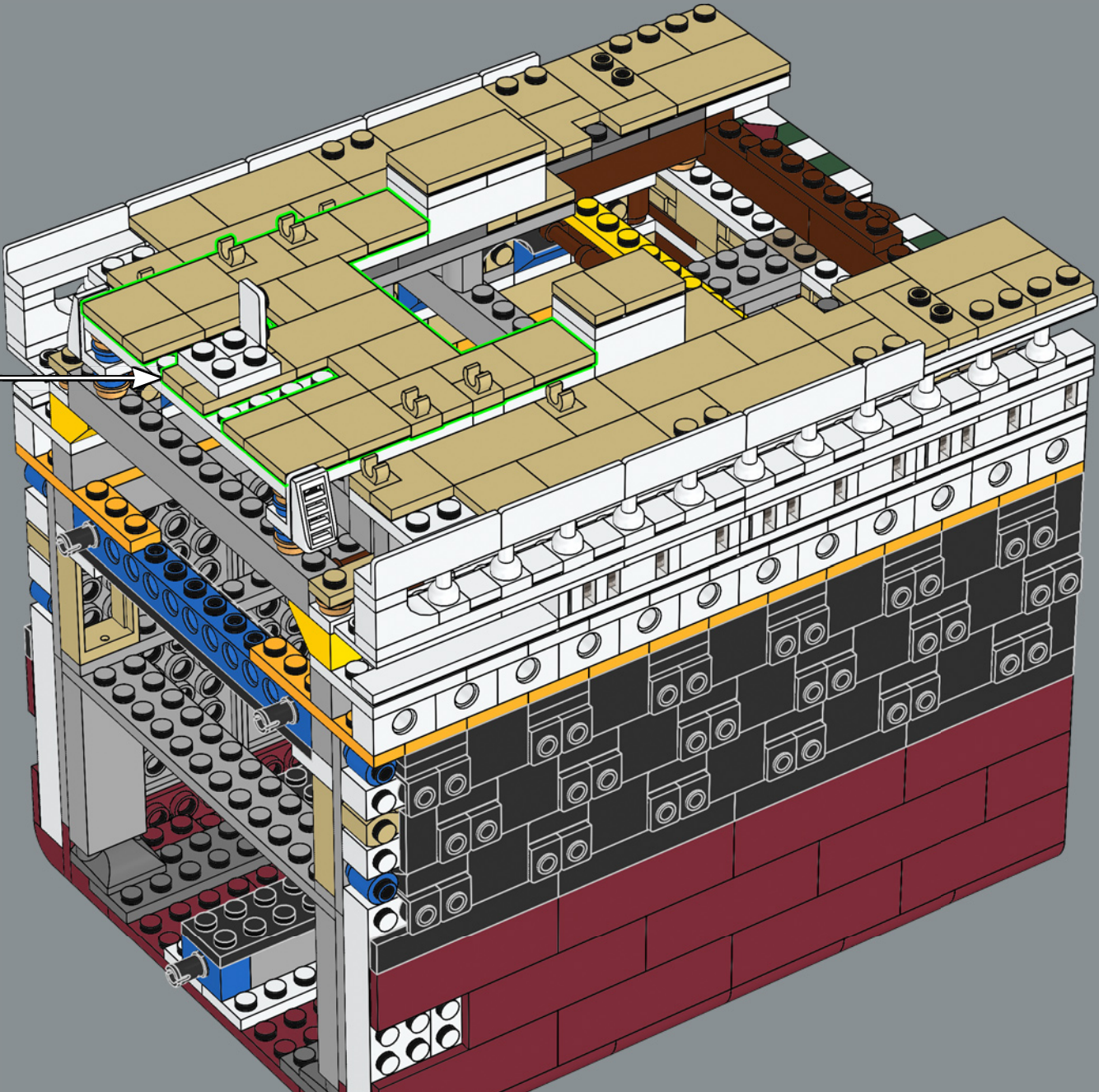
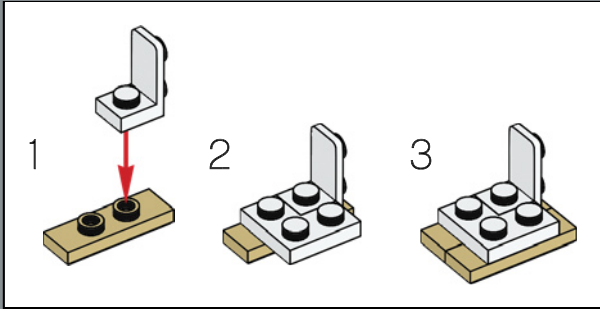



227

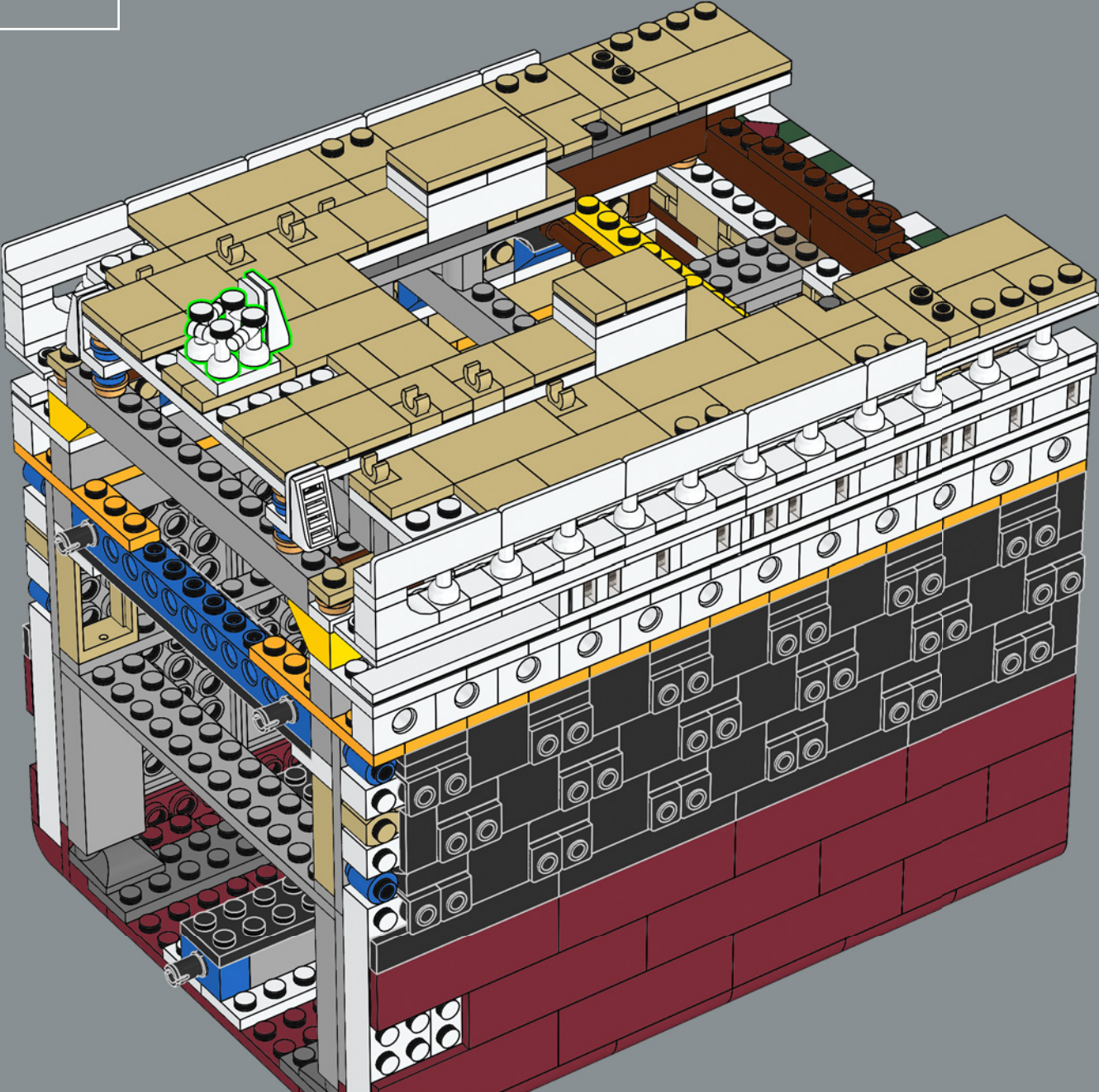

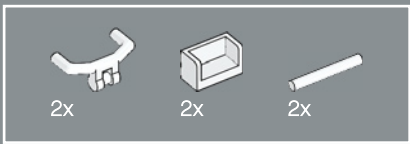

228

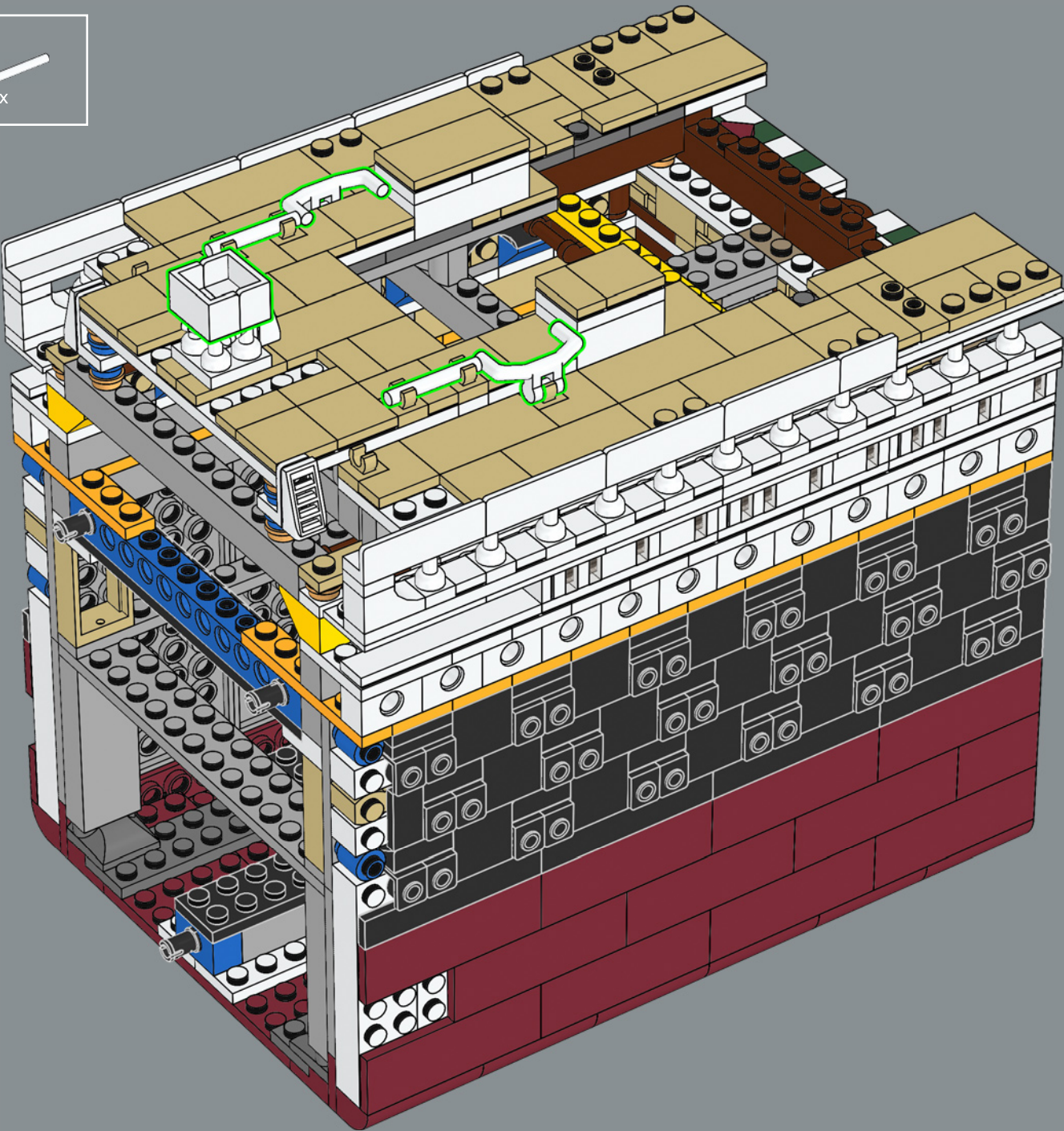

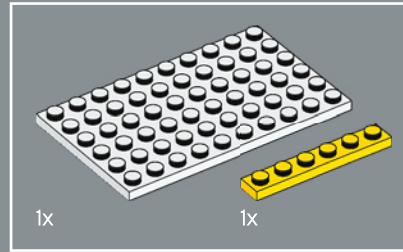
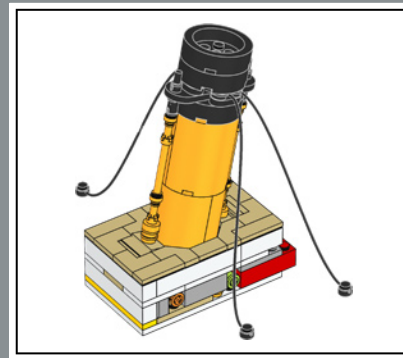
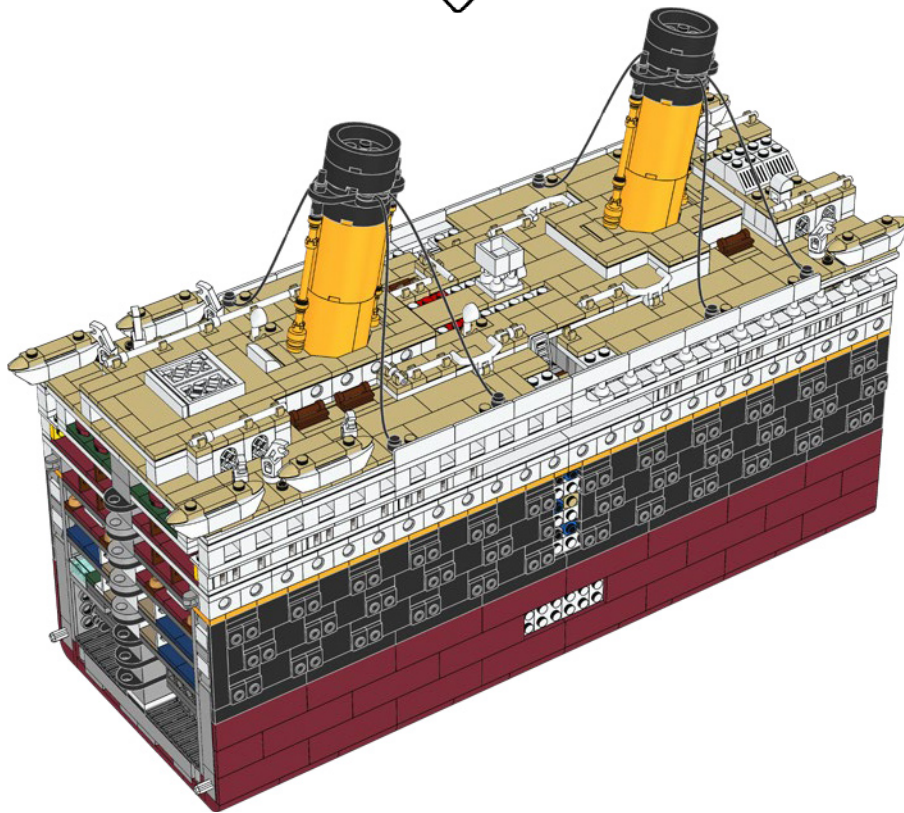
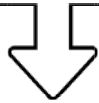

229

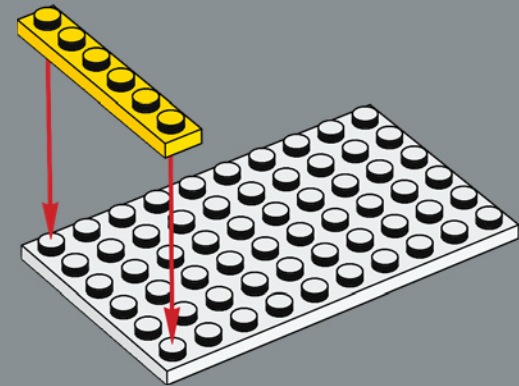

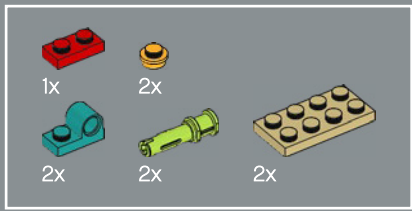

230

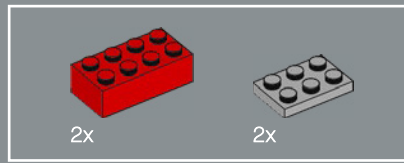
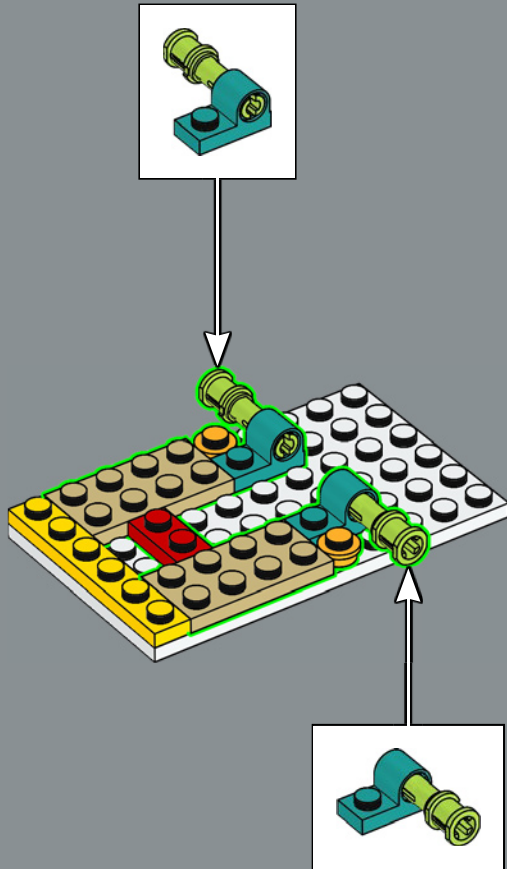

231

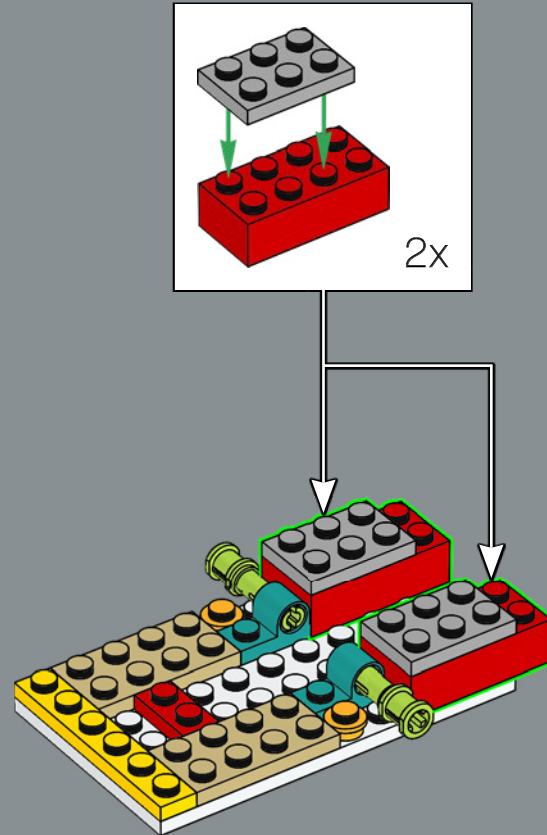

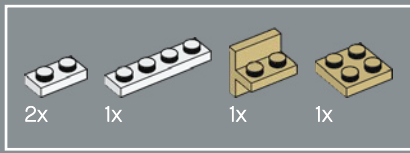

232

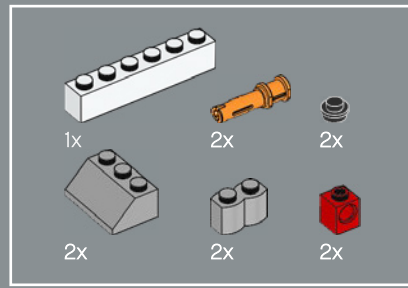
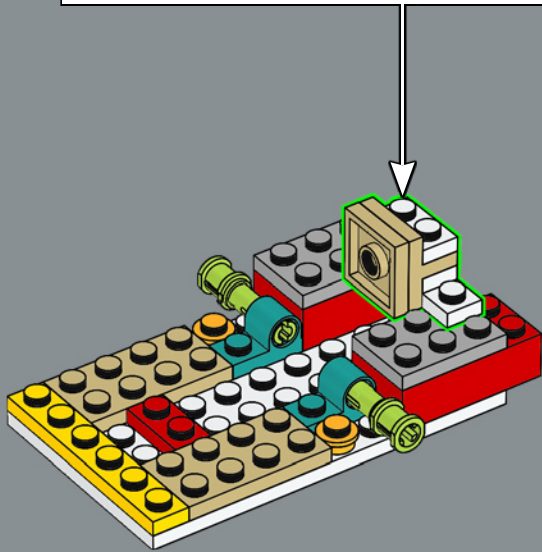
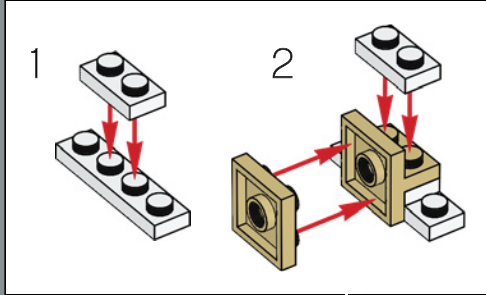

233

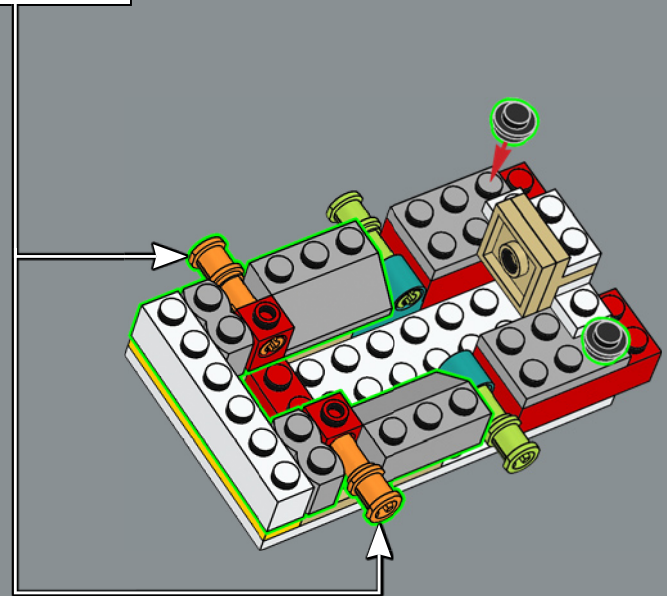
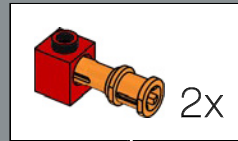

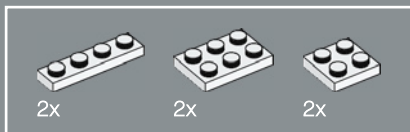

234

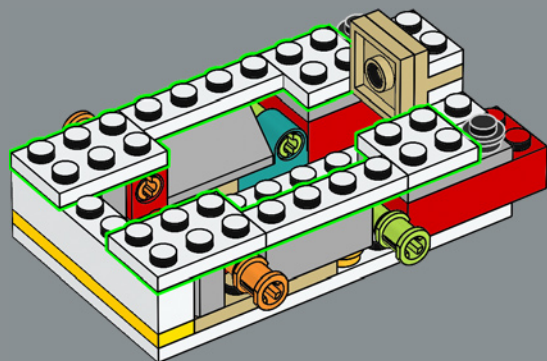

235

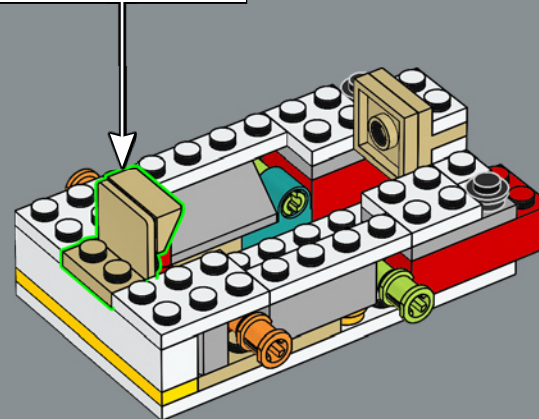
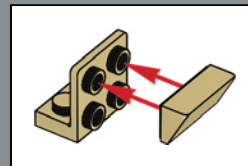

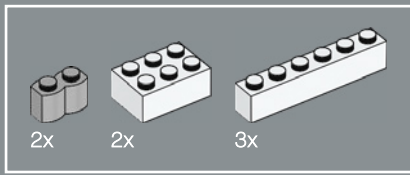

236

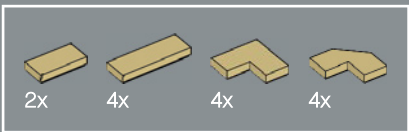
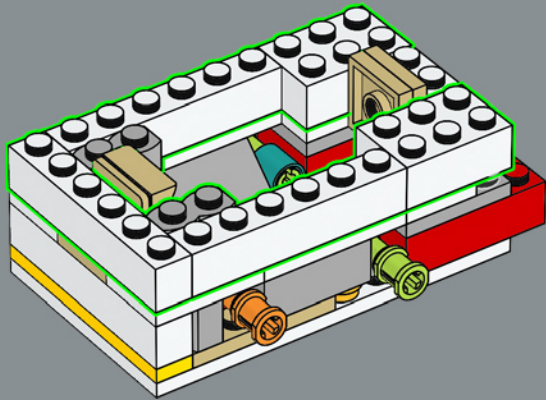

237

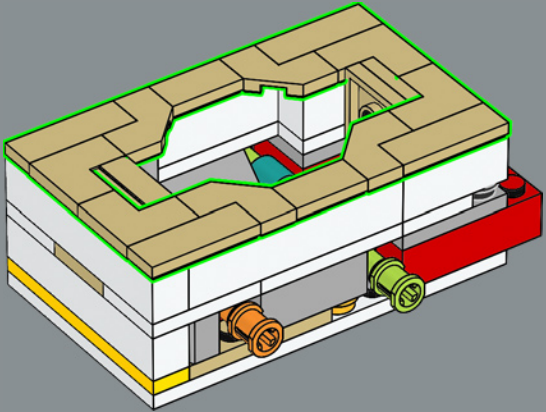

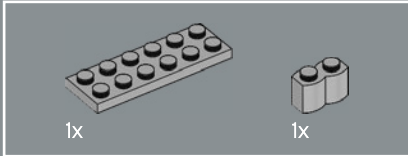
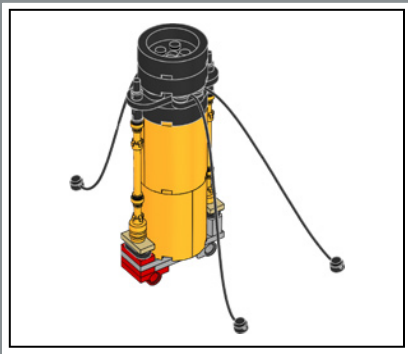

238

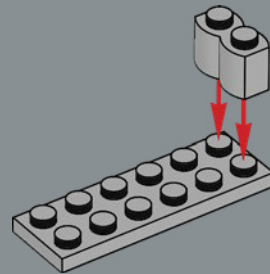

239

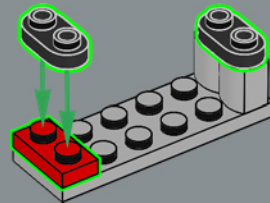

240

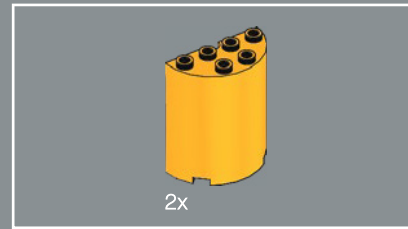
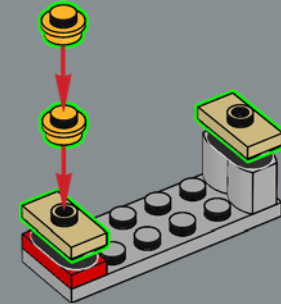

241

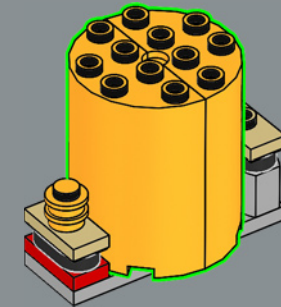

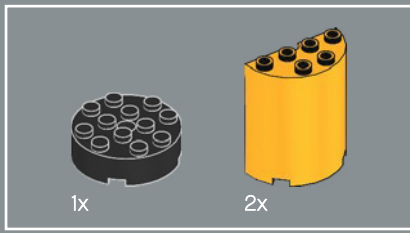

242

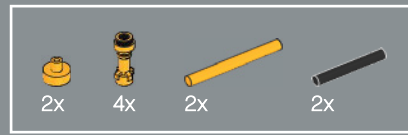
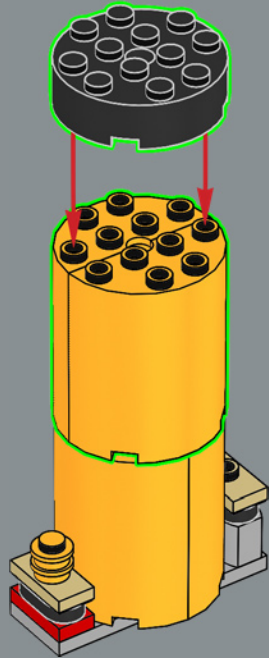

243

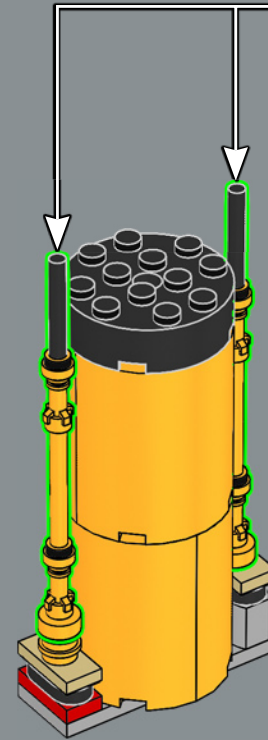
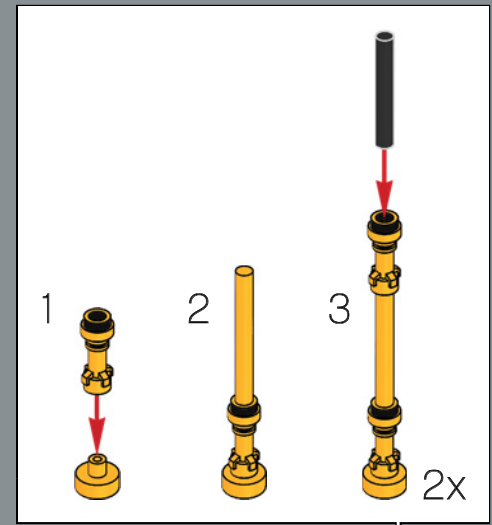

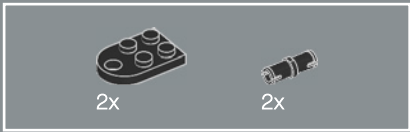

244

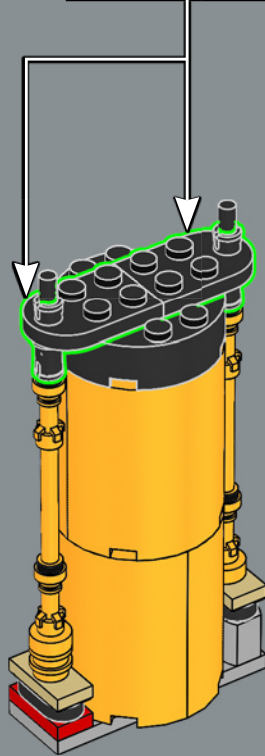
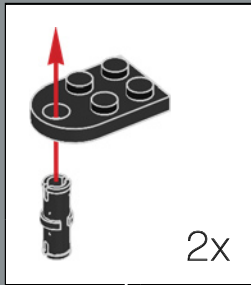

245

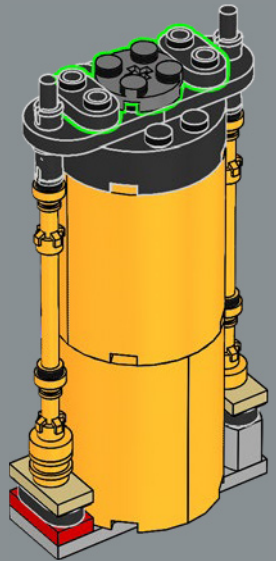



246

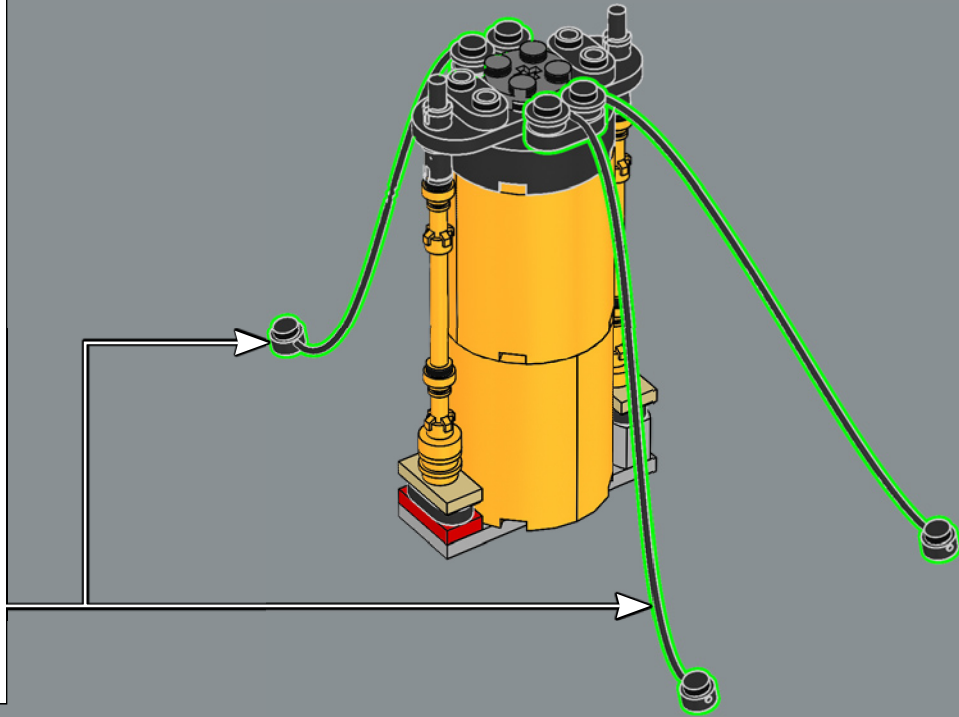
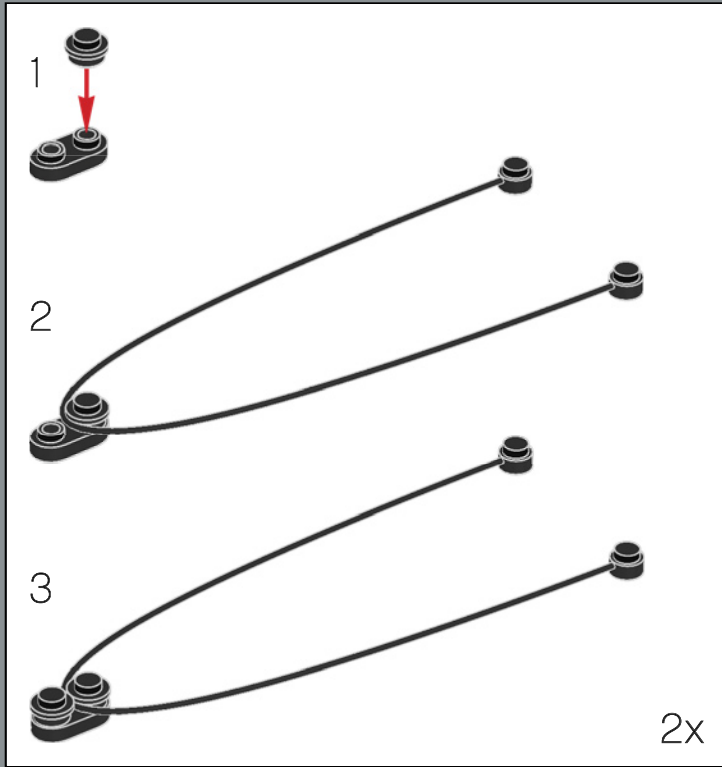

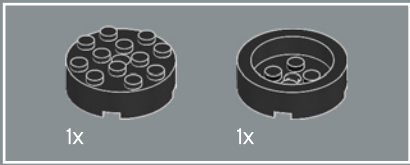

247

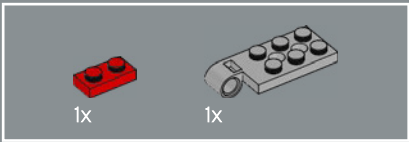
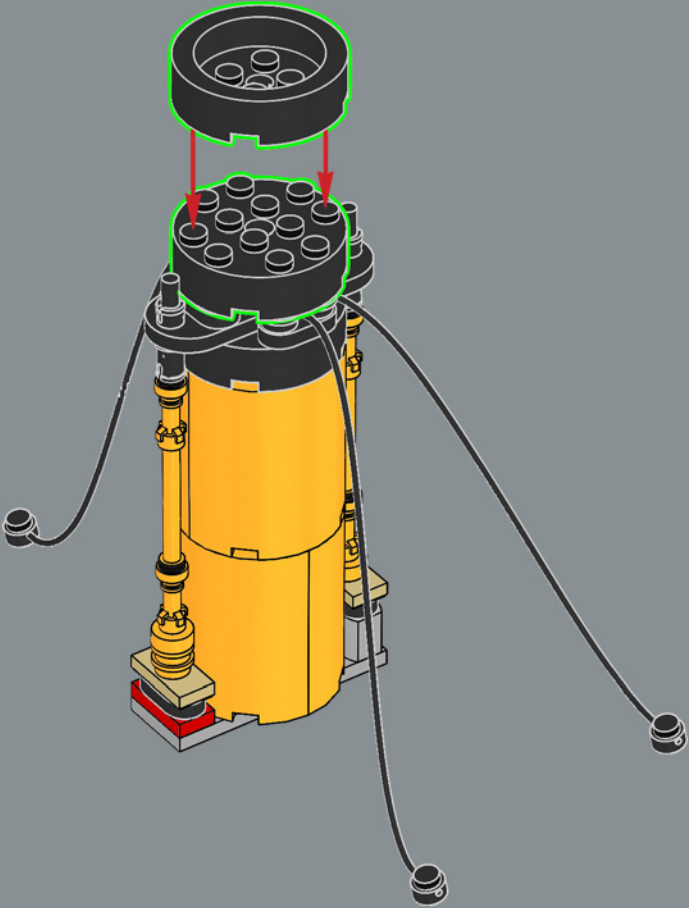

248

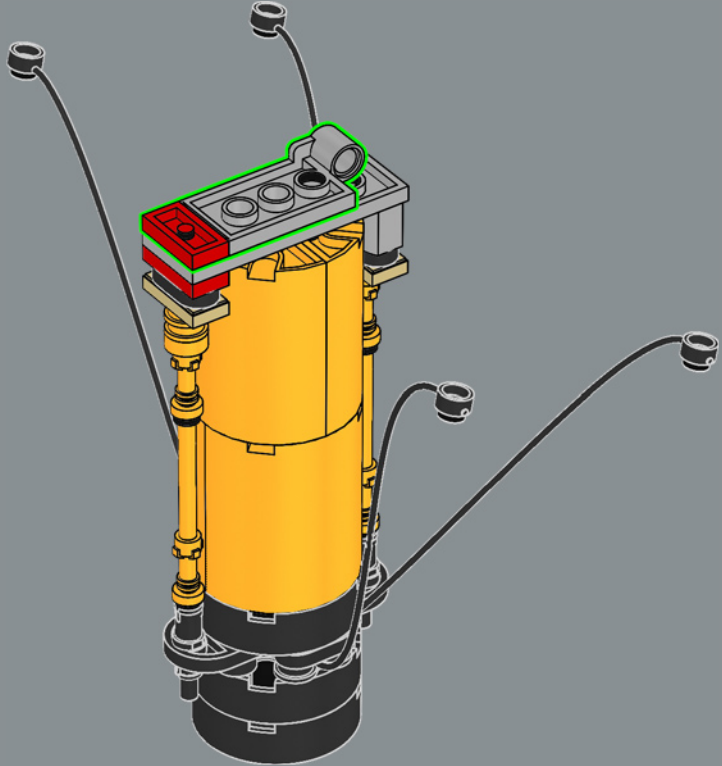

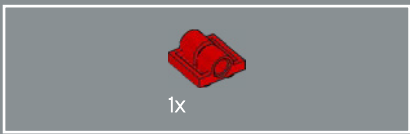

249

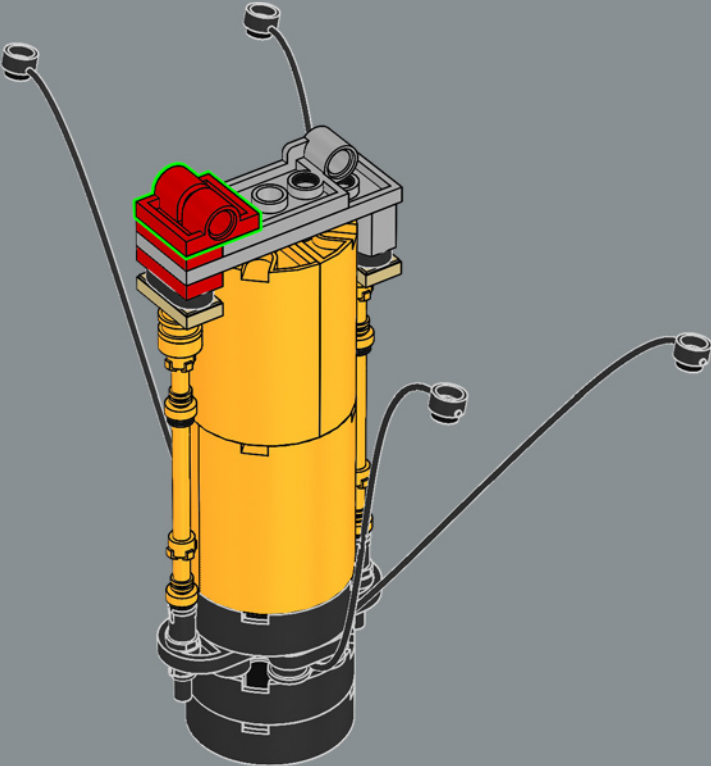

250

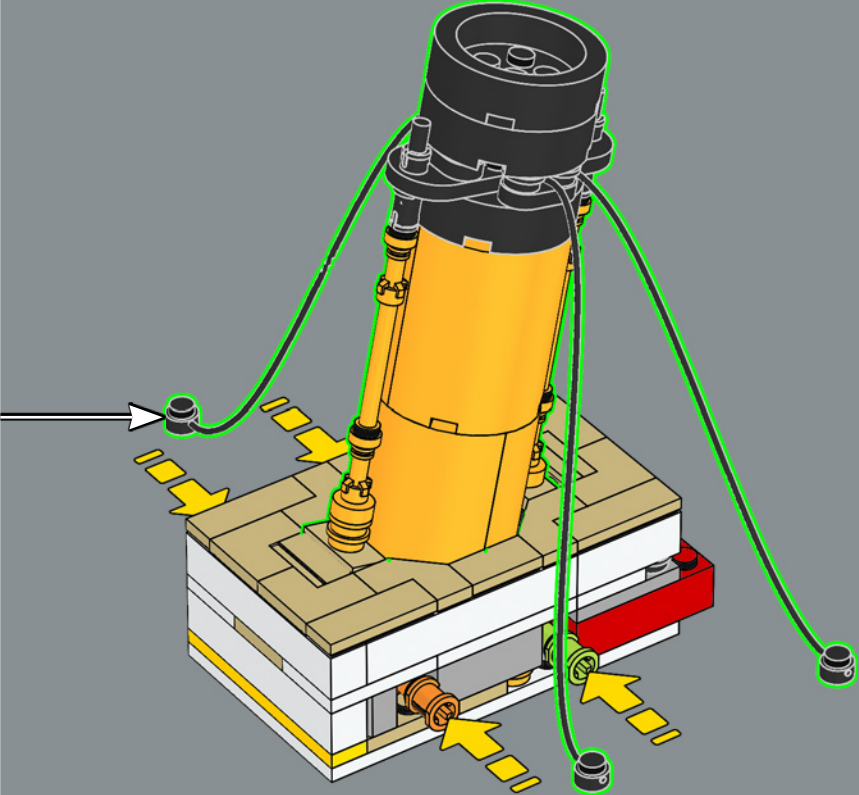

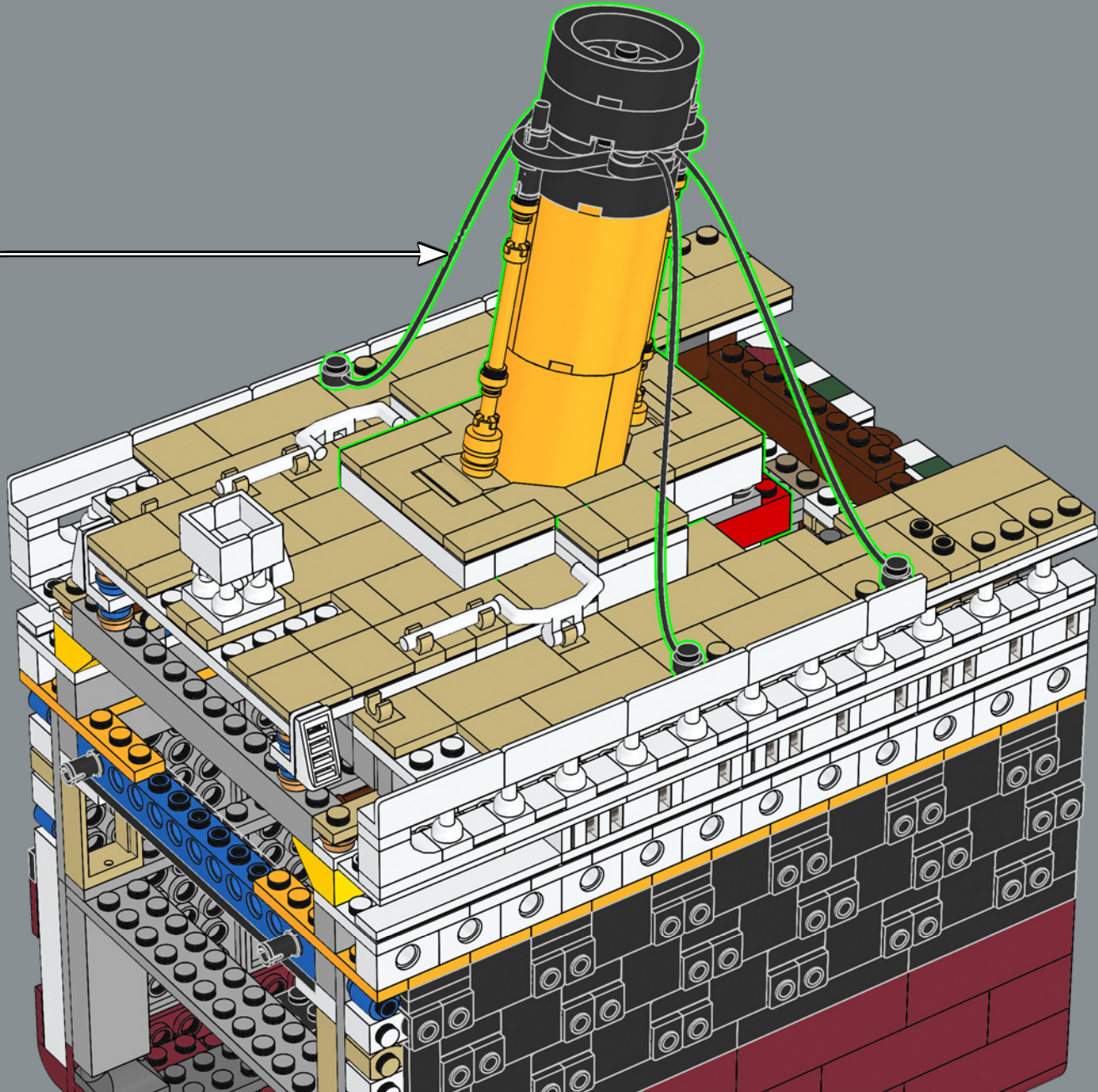

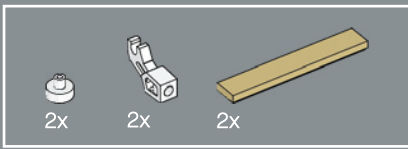

252

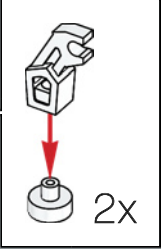
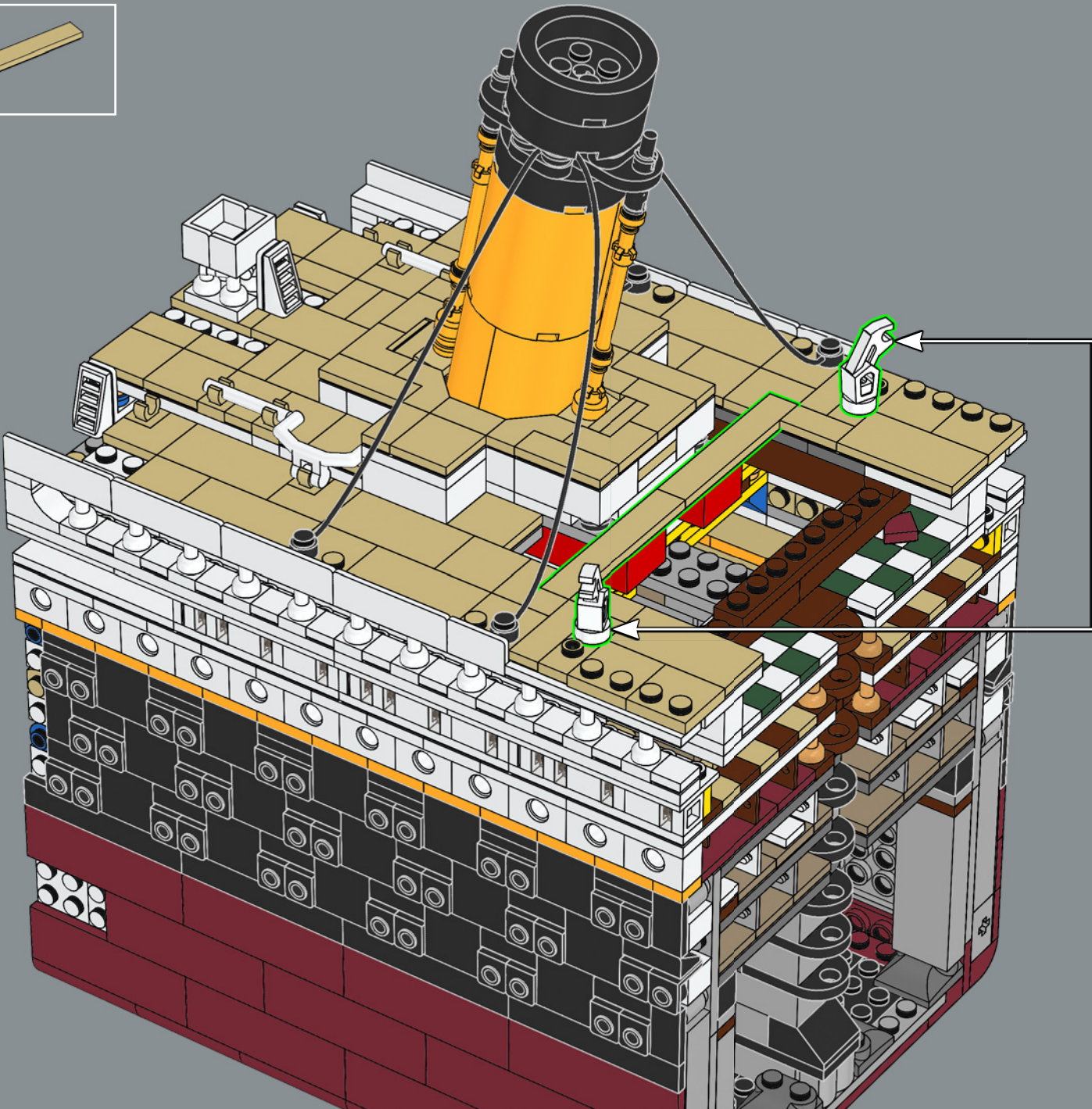

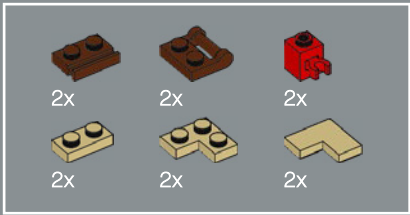

253

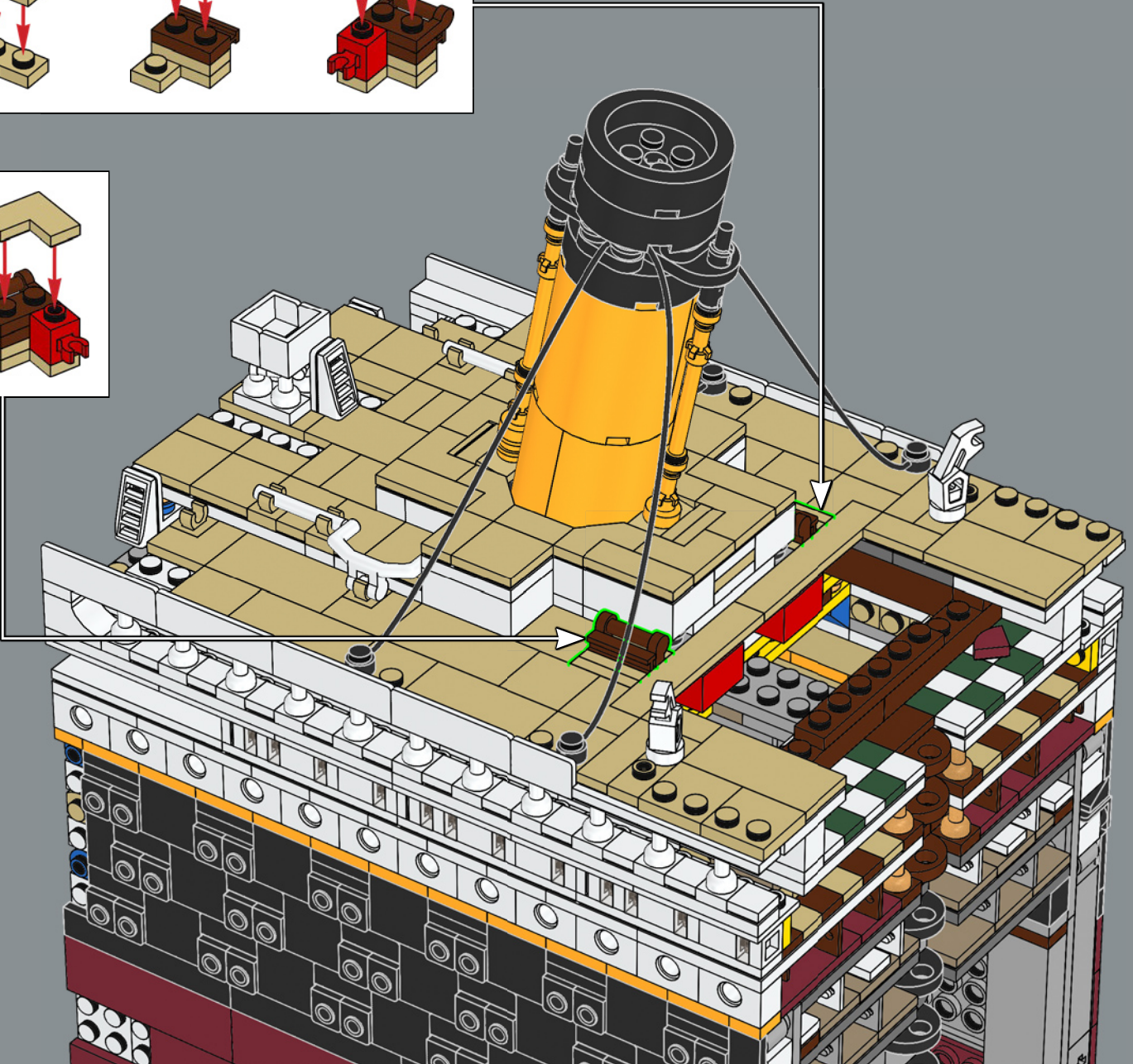
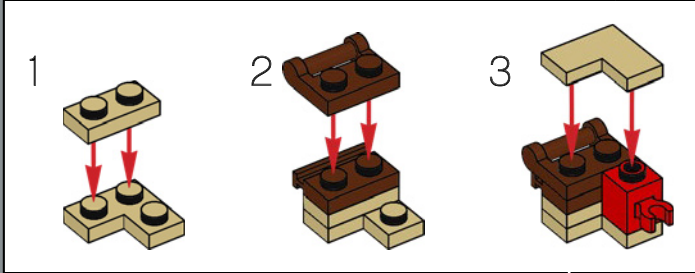
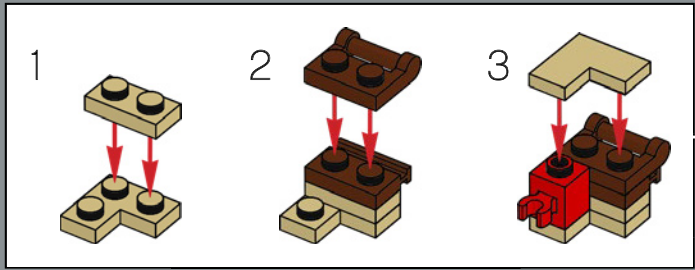

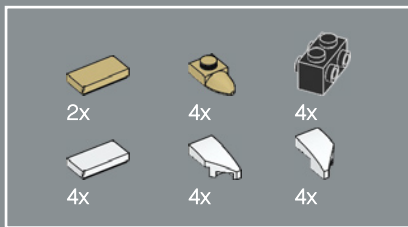

254

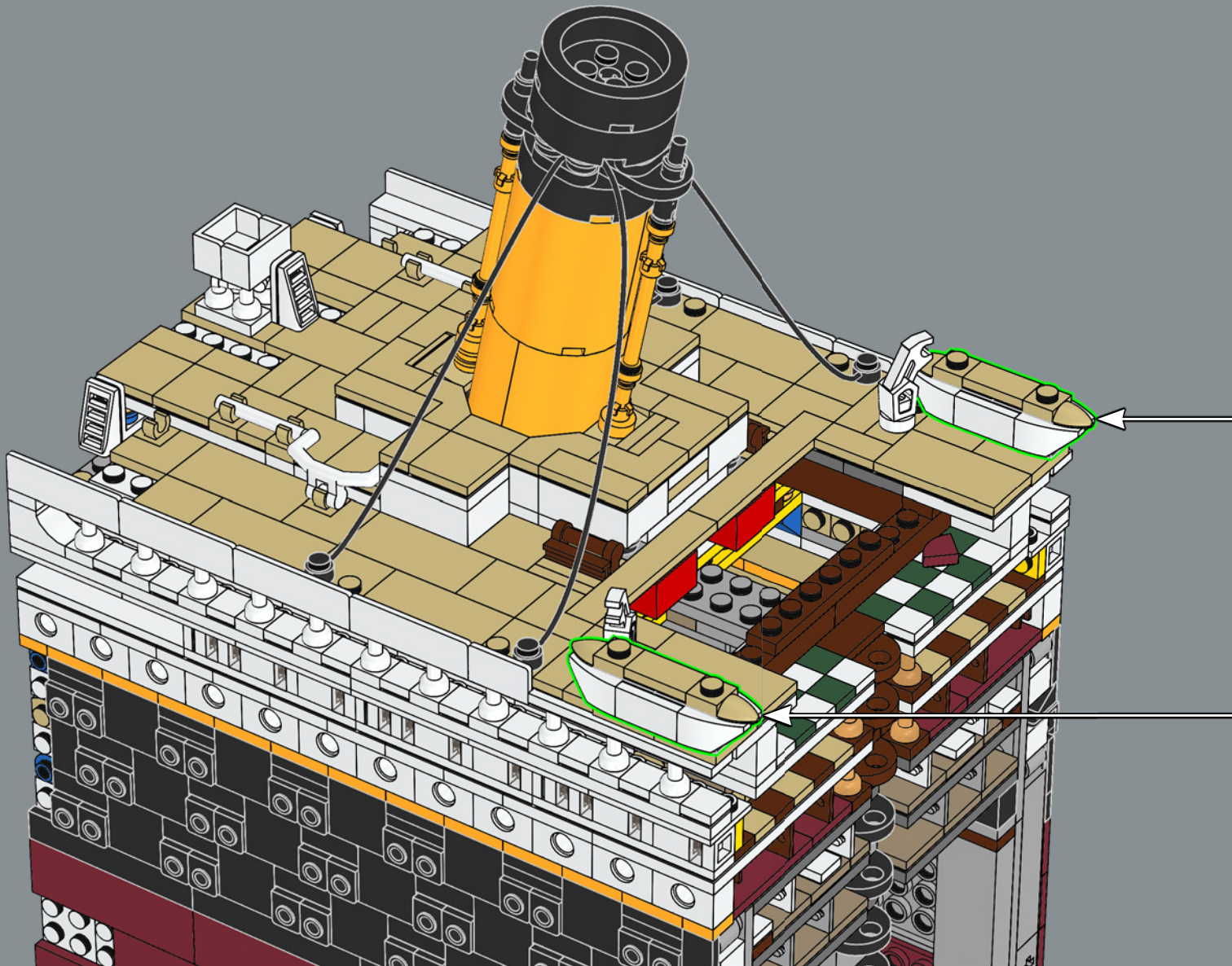
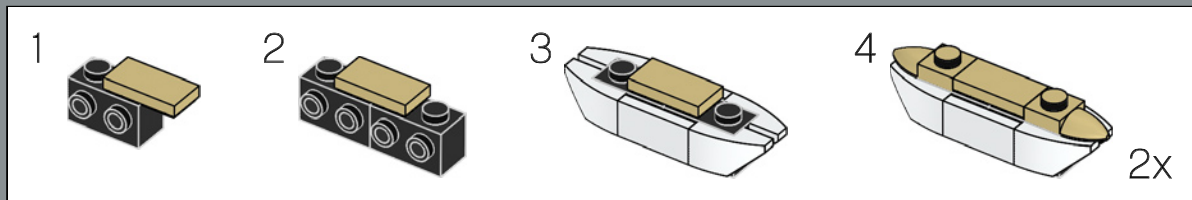

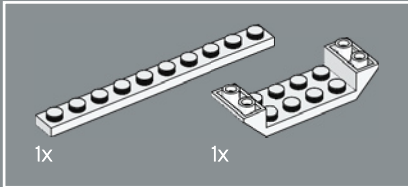
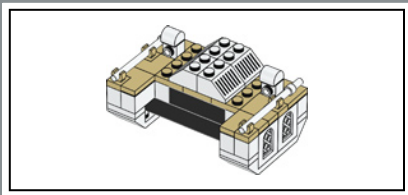

255

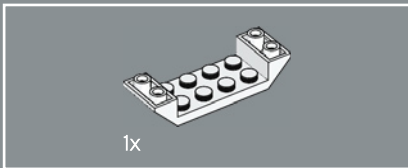
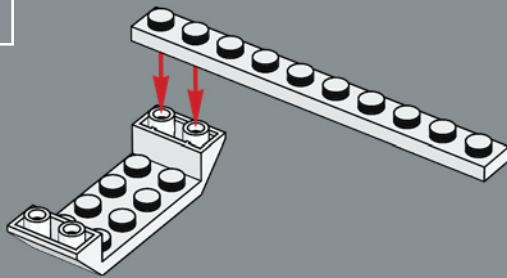

256

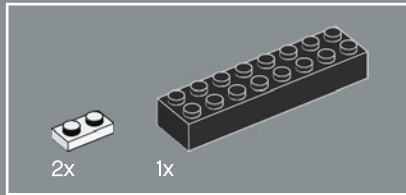
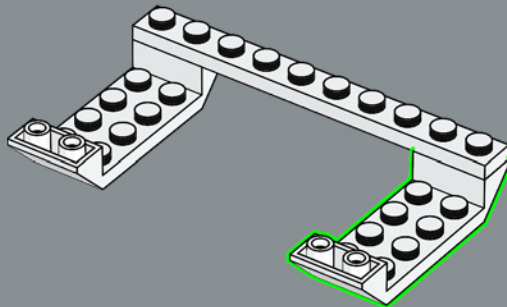

257

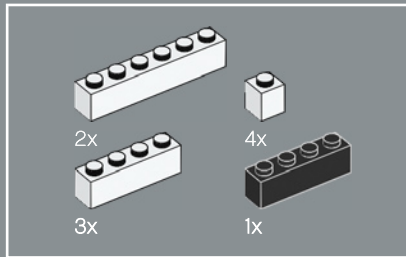
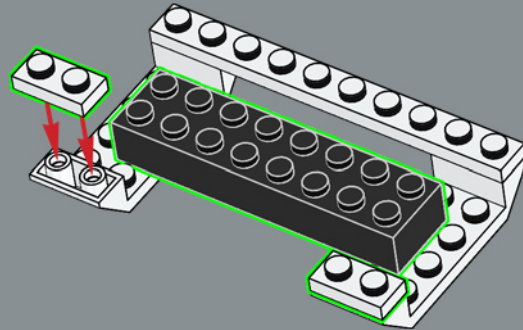

258

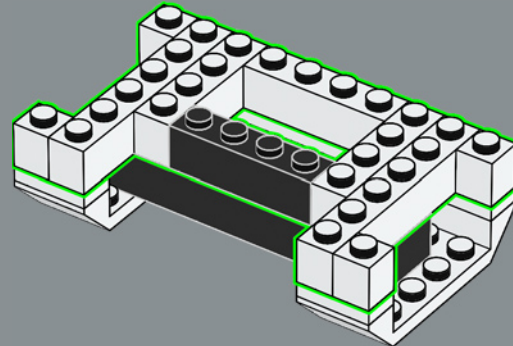

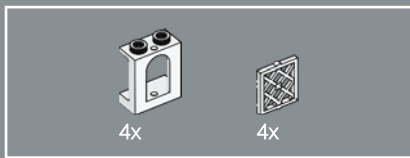

259

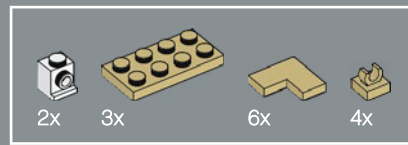
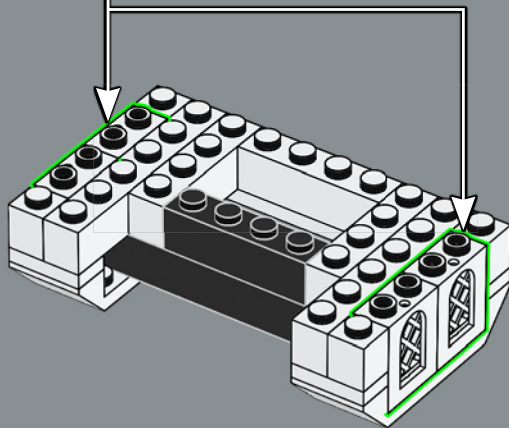
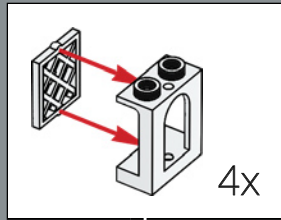

260

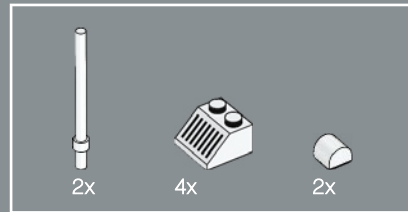
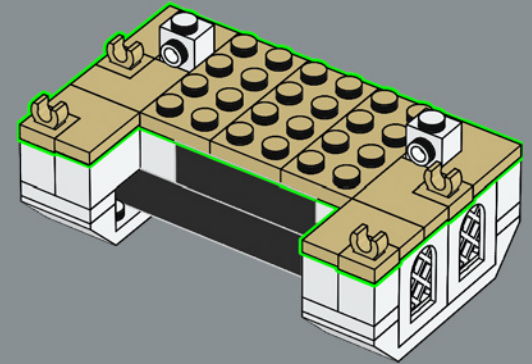

261

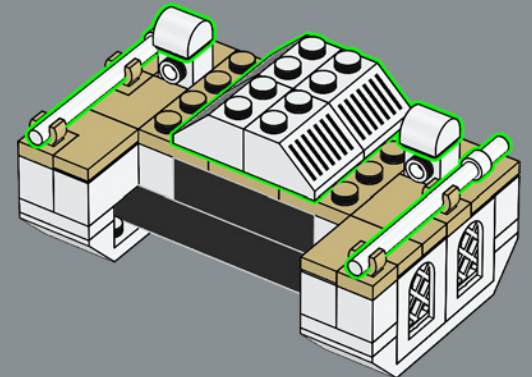

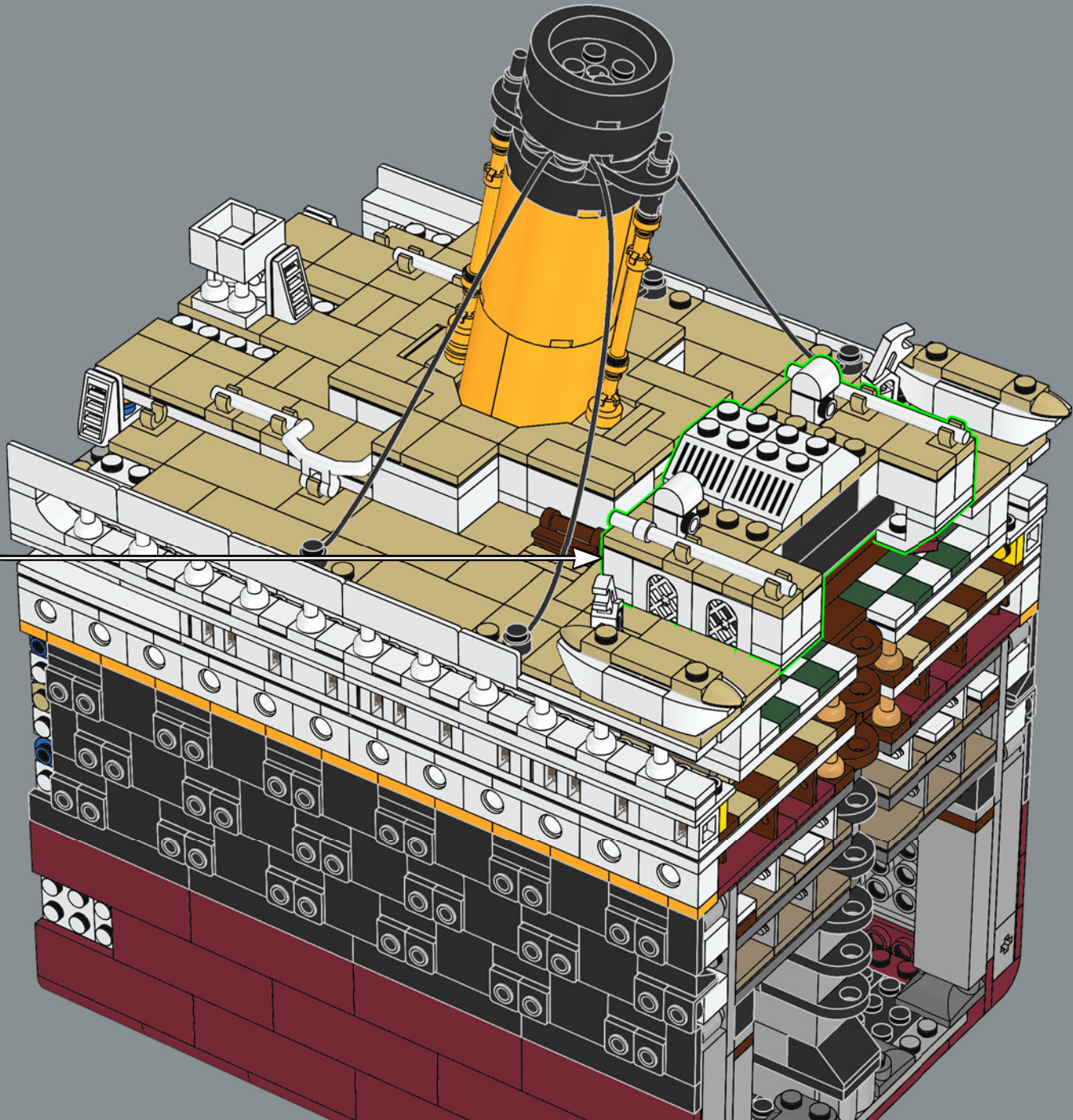

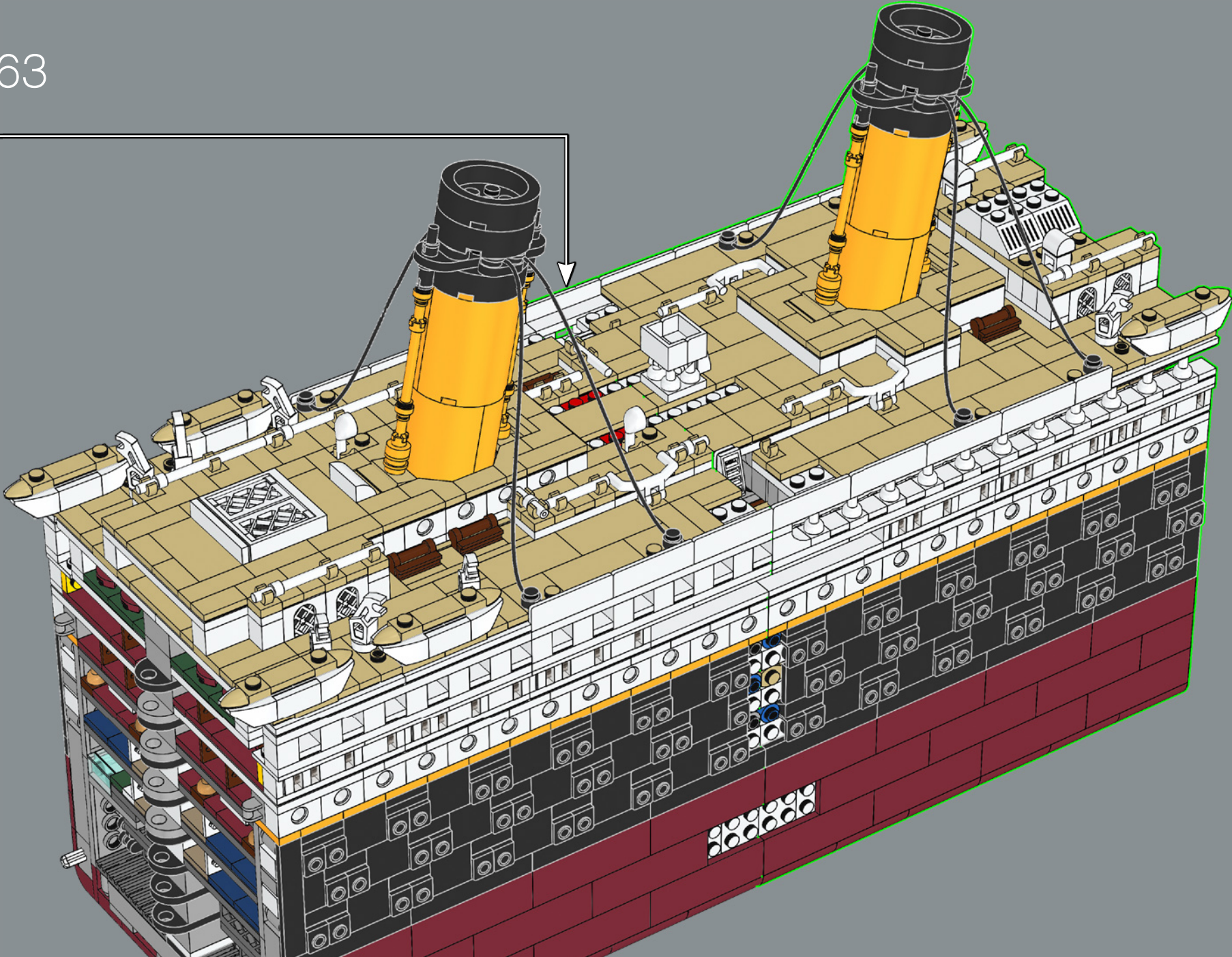

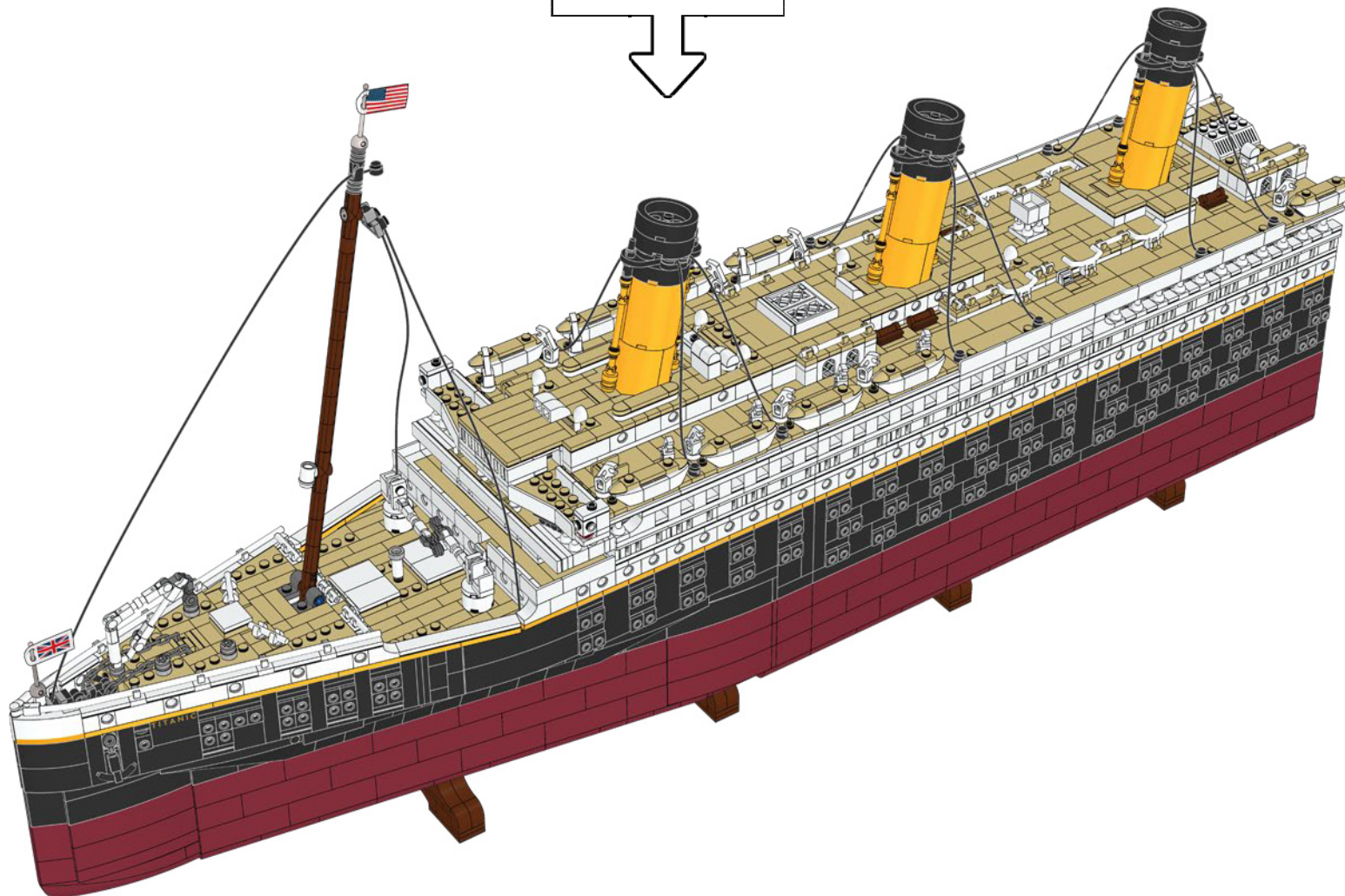

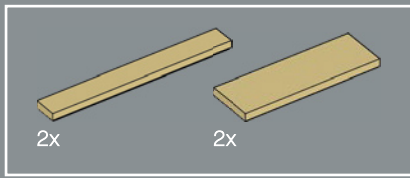

264

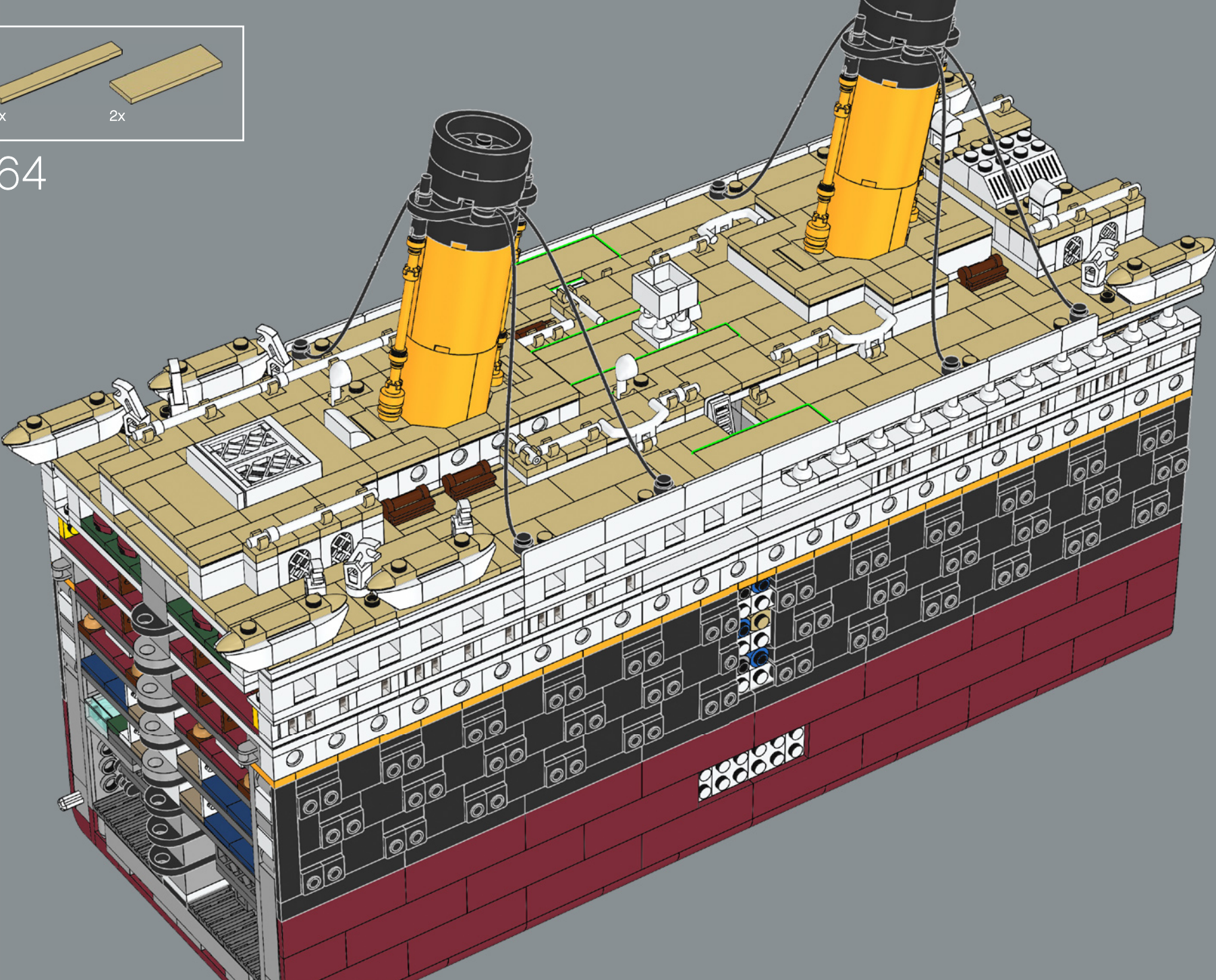

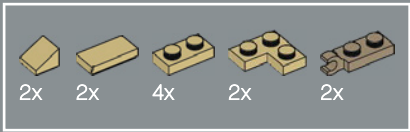

265

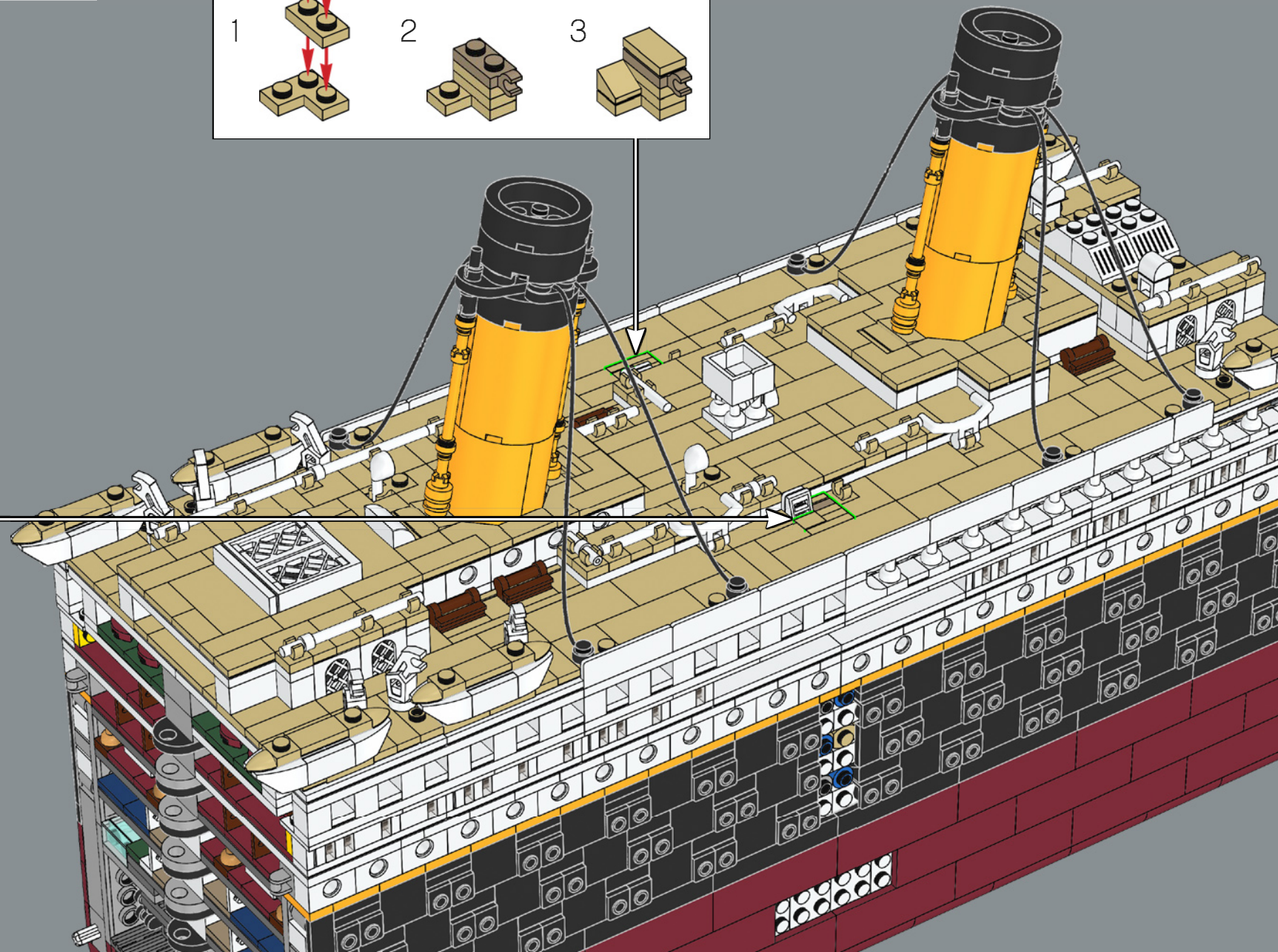
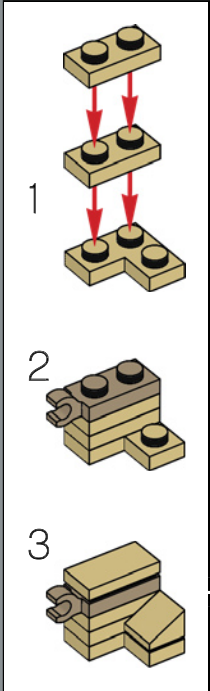
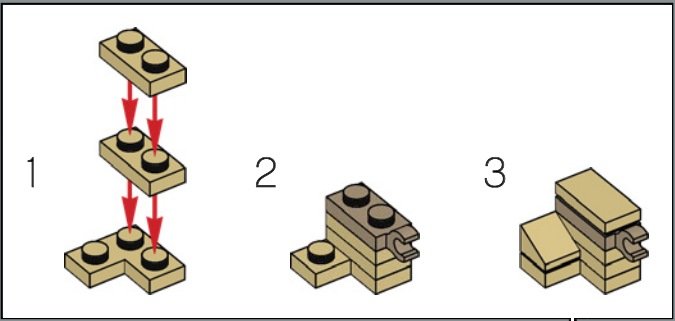

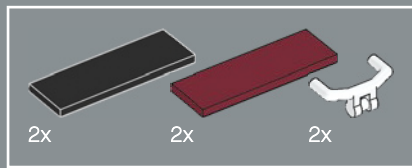

266

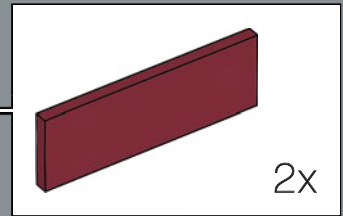
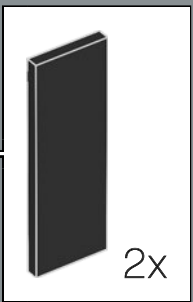
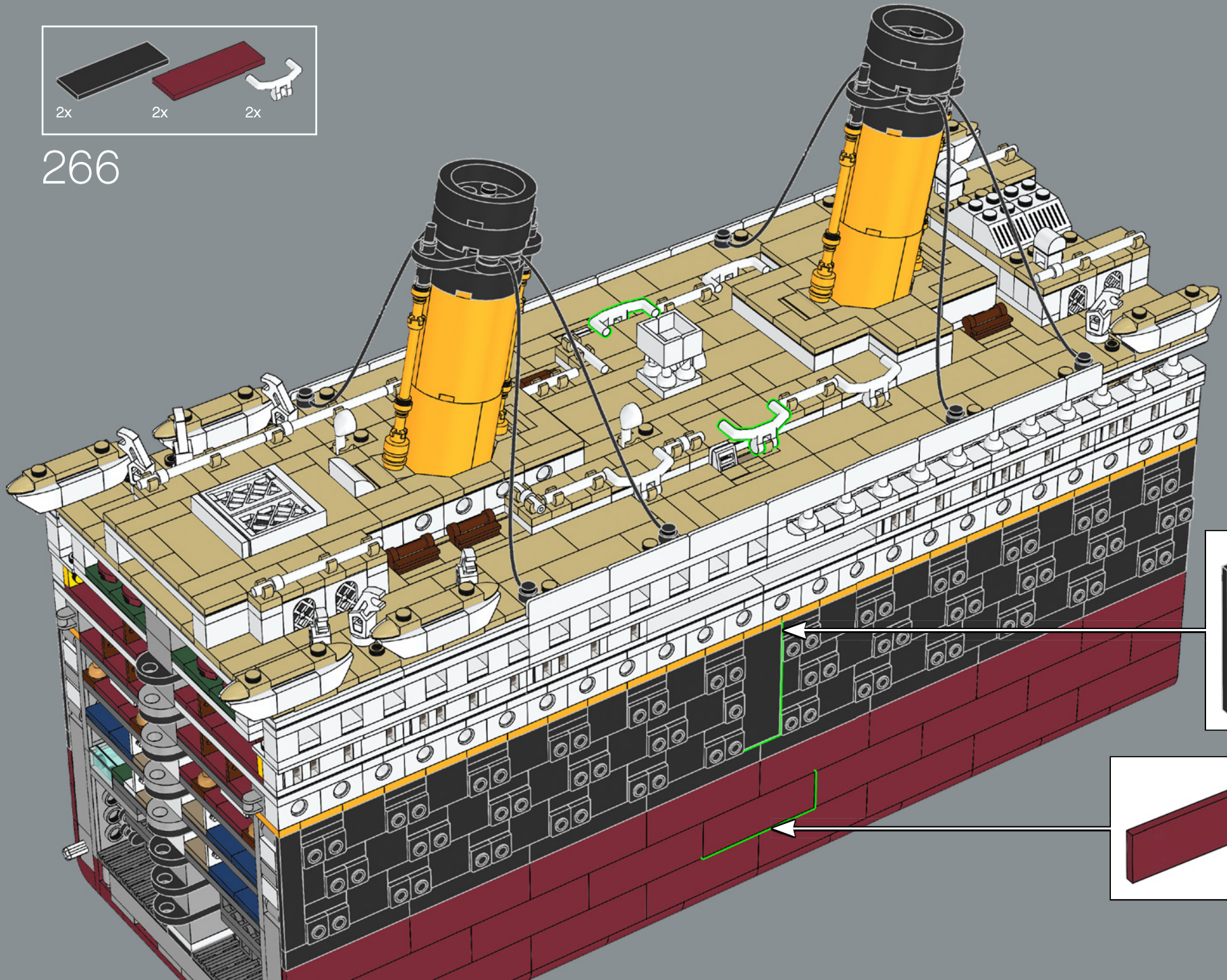

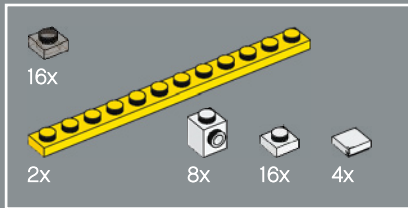
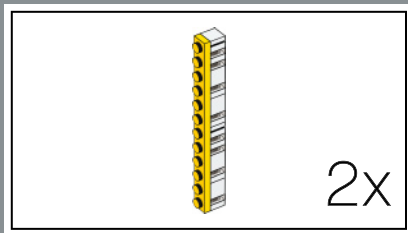

267

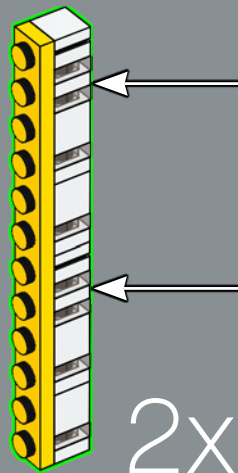
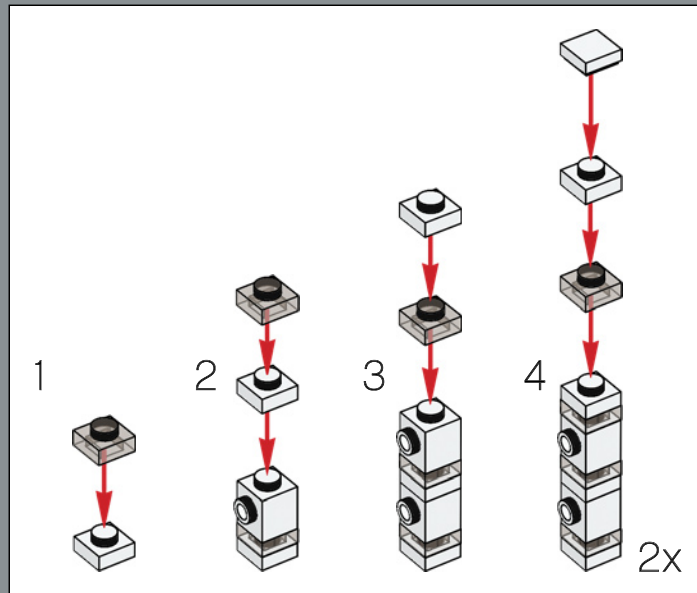

268

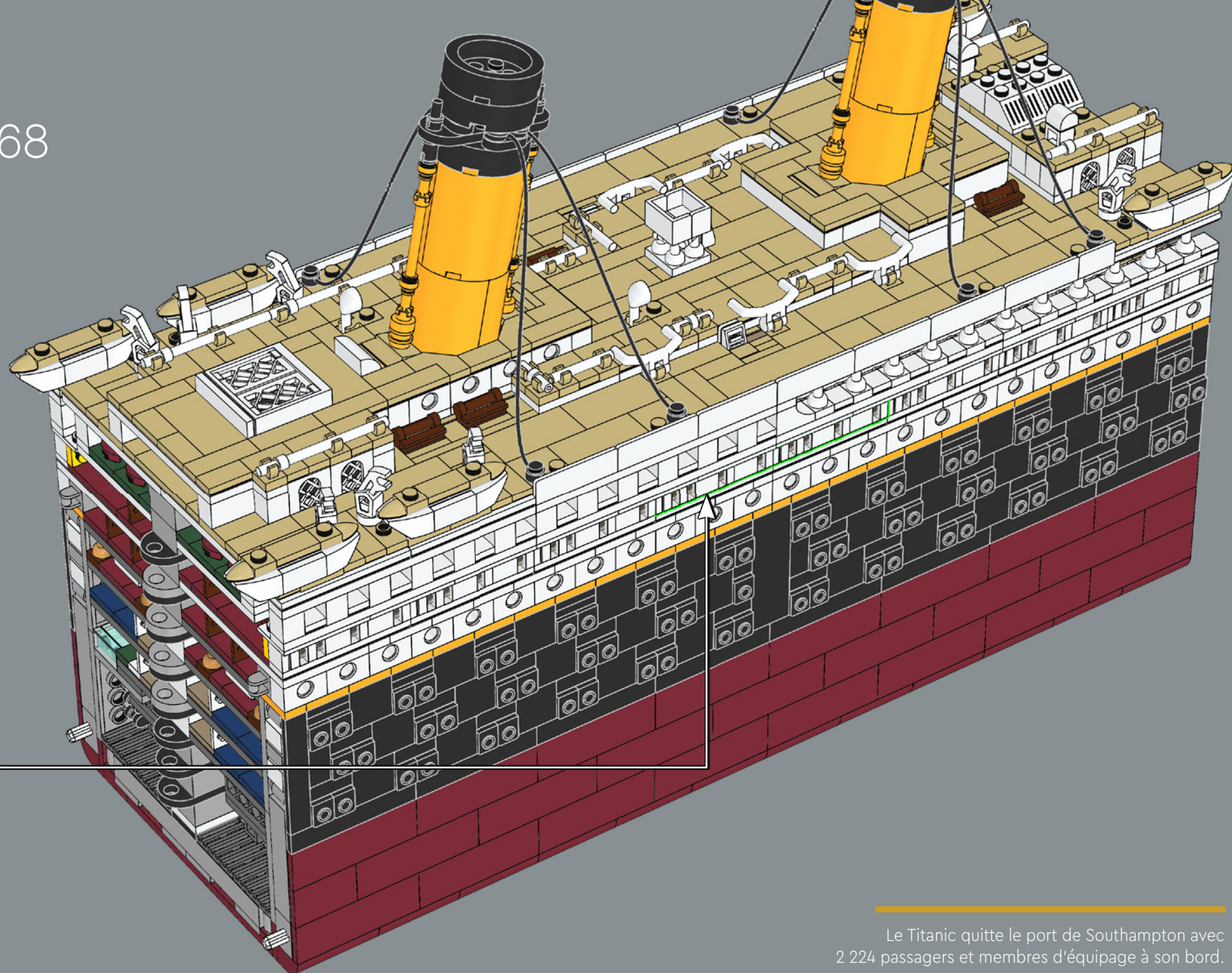

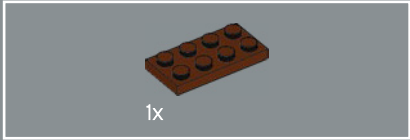
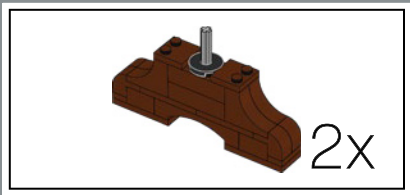

269

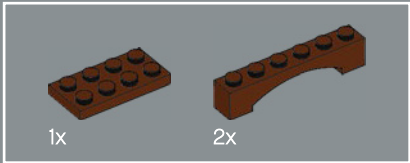
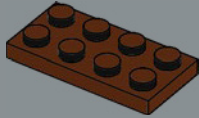

270

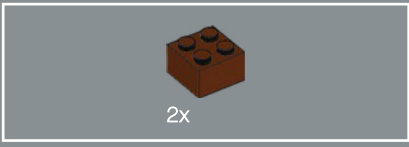
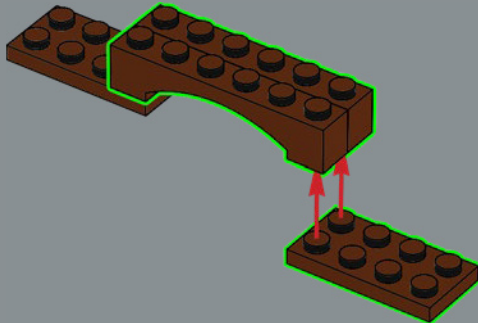

271

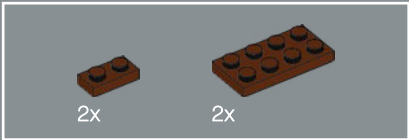
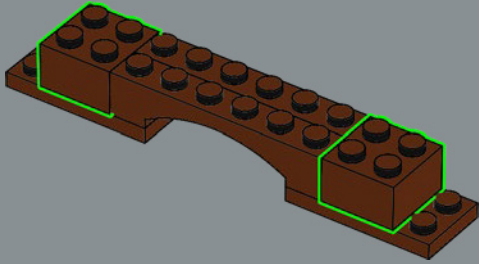

272

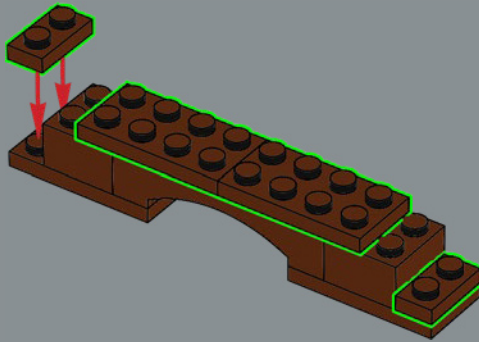



273

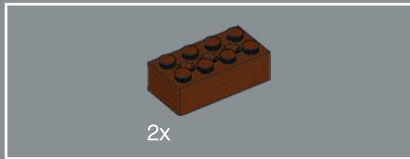
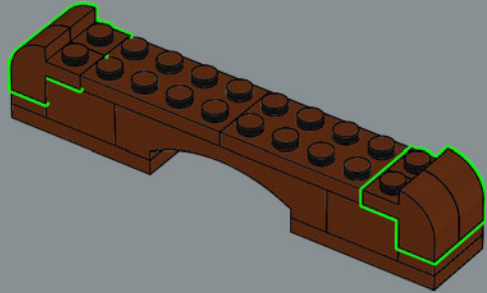

274

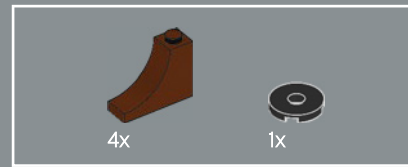
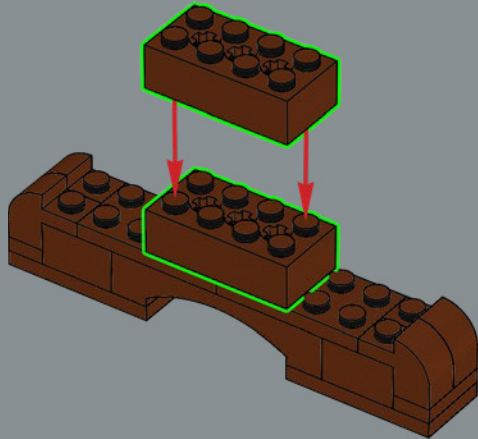

275

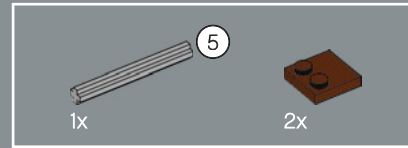
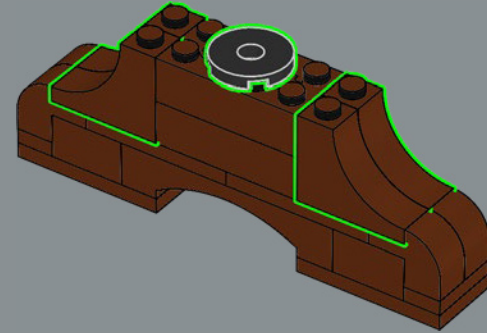

276

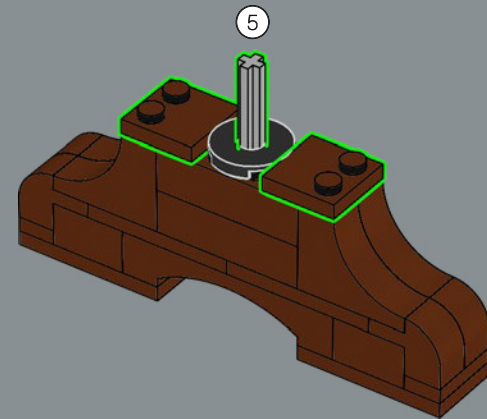

2x



277

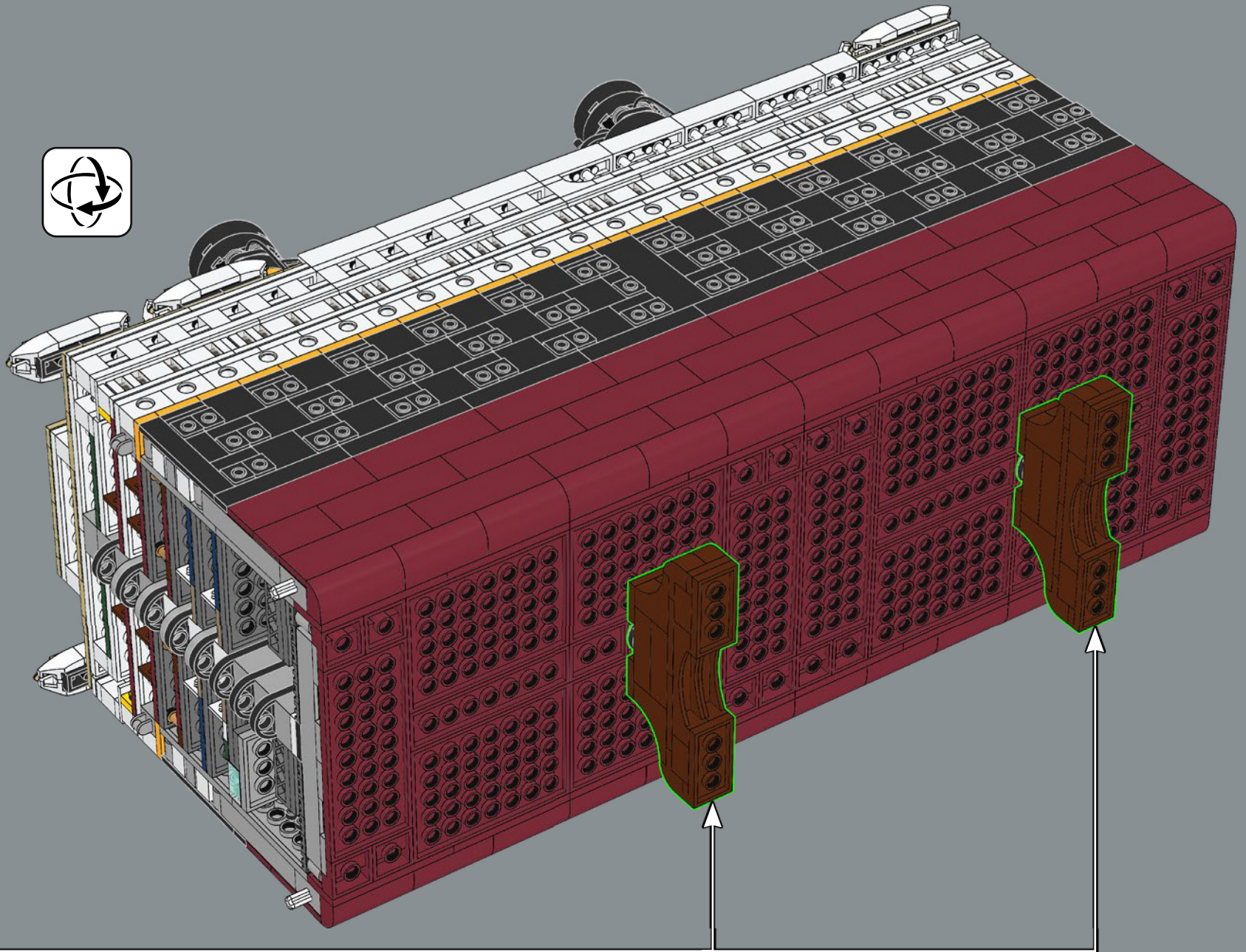

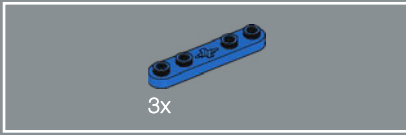
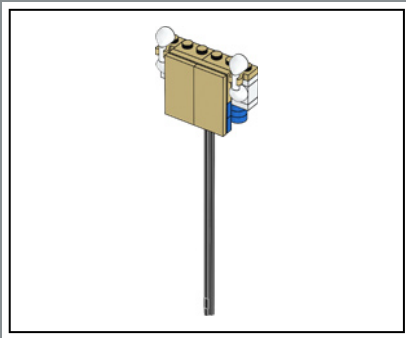

278

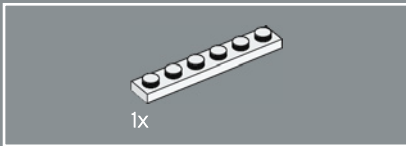
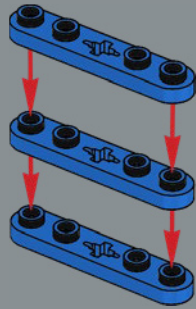

279

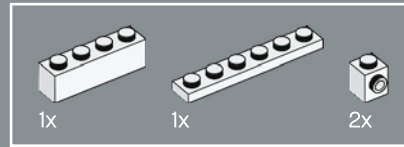
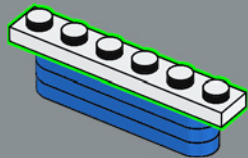

280

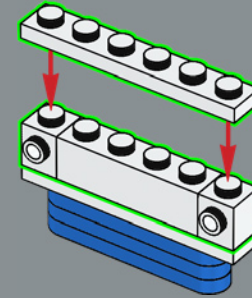

281

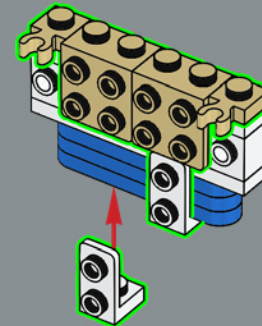

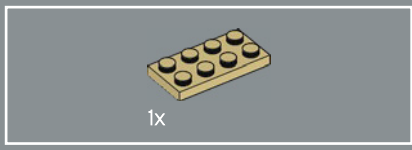

282

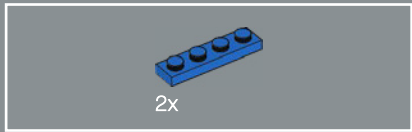
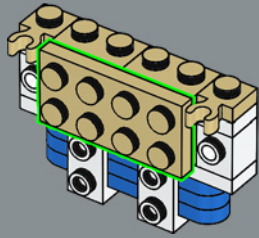

283

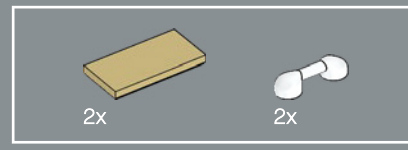
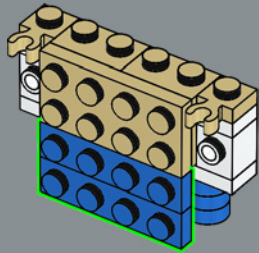

284

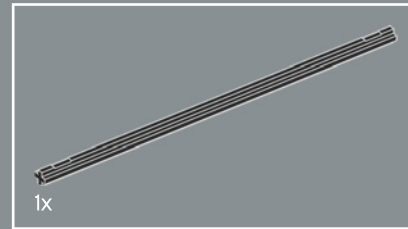
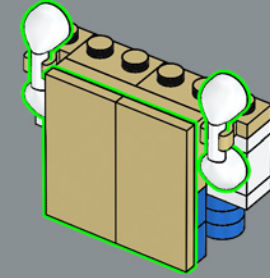

285

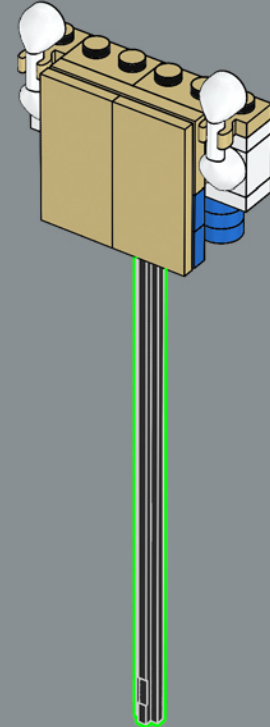

286

